

—
SAFETY PRODUCTS

Safety Interlock Switch with Guard Locking MKey9-series Product Manual



Read and understand this document

Please read and understand this document before using the products. Please contact ABB for any questions or comments.

Suitability for use

ABB Electrification Sweden AB shall not be responsible for conformity with any standards, codes, or regulations that apply to the combination of products in the customer's application or use of the product. Third party certificates for the products are available at <https://new.abb.com/low-voltage/products/safety-products>. This information by itself is not sufficient for a complete determination of the suitability of the products in combination with the end product, machine, system, or other application or use.

The following are some examples of applications for which particular attention must be given. This is not intended to be an exhaustive list of all possible uses of the products, nor is it intended to imply that the uses listed may be suitable for the products:

- Outdoor use uses involving potential chemical contamination or electrical interference, or conditions or uses not described in this document.
- Nuclear energy control systems, combustion systems, railroad systems, aviation systems, medical equipment, amusement machines, vehicles, and installations subject to separate industry or government regulations.
- Systems, machines, and equipment that could present a risk to life or property.

Please know and observe all prohibitions of use applicable to the products.

NEVER USE THE PRODUCTS FOR AN APPLICATION INVOLVING SERIOUS RISK TO LIFE OR PROPERTY WITHOUT ENSURING THAT THE SYSTEM AS A WHOLE HAS BEEN DESIGNED TO ADDRESS THE RISKS, AND THAT THE ABB PRODUCT IS PROPERLY RATED AND INSTALLED FOR THE INTENDED USE WITHIN THE OVERALL EQUIPMENT OR SYSTEM.

Descriptions and examples show how the product works and can be used. It does not mean that it fulfills the requirements for all types of machines and processes. The buyer/user is responsible for installing and using the product according to applicable standards and regulations. We reserve the right to make changes to the product and the documentation without prior notice.

Table of Contents

1 Introduction	4
Scope	4
Audience.....	4
Prerequisites	4
Special notes.....	4
2 Overview.....	5
General description	5
Safety regulations	5
Function description	6
3 Connections	7
4 Installation and maintenance.....	9
Installation.....	9
Maintenance	10
Minimum safety distance.....	11
5 Functions	12
Manual unlock function (auxiliary release).....	12
6 Disassembly and disposal	13
Disassembly	13
Disposal.....	13
7 Model overview.....	14
Actuators	14
Accessories.....	14
Dimensions.....	15
8 Technical data	18
9 Declarations of conformity	20

1 Introduction

Scope

The purpose of these instructions is to describe the safety interlock switch MKey9-series, to provide the necessary information required for assembly, installation, checks and adjustments after installation, and maintenance. The instructions also include information necessary to connect MKey9 to a safety circuit.

Audience

This document is intended for authorized installation personnel.

Prerequisites

It is assumed that the reader of this document has knowledge of the following:

- Basic knowledge of ABB Safety products.
- Knowledge of safety devices and safety locks.
- Knowledge of machine safety.

Special notes

Pay attention to the following special notes in the document:

-  **Warning!** Danger of severe personal injury!
An instruction or procedure which, if not carried out correctly, may result in injury to the technician or other personnel.
- Caution!** Danger of damage to the equipment!
An instruction or procedure which, if not carried out correctly, may damage the equipment.
- NB:** Notes are used to provide important or explanatory information.

2 Overview

General description

MKey9 interlock switches are designed to provide position interlock detection for moving guards. It is designed to fit the leading edge of sliding, hinged or lift off machine guards. The actuator is fitted to the moving part of the guard and is aligned to the switch entry aperture. The possibility to lock the switch in the protective position prevents unwanted access to machinery until hazardous operations have ceased.

The locking is useful when applications include:

- processes which cannot be interrupted, such as welding.
- machinery with a long stopping procedure, such as paper machinery that requires a long braking operation.
- prevention of unauthorized access to a particular area.

Safety regulations

Warning!

Carefully read through this entire manual before using the device.

The devices shall be installed by a trained electrician following the local standards and legal regulations.

Failure to comply with instructions, operation that is not in accordance with the use prescribed in these instructions, improper installation or handling of the device can affect the safety of people and the plant.

For installation and prescribed use of the product, the special notes in the instructions must be carefully observed and the technical standards relevant to the application must be considered.

In case of failure to comply with the instructions or standards, especially when tampering with and/or modifying the product, any liability is excluded.

Function description

Safety interlock switches with guard locking are designed to fit to the leading edge of sliding or hinged guard doors to provide positively operated switching contacts and a tamper resistant key mechanism. They are designed to provide robust position interlock detection and to keep moving guards closed. The switch is rigidly mounted to the frame of the guard or machine. The actuator is fitted to the moving part of the guard, and is aligned to the switch entry aperture, placed on the frame of the guard. The actuator profile is designed to match a cam mechanism within the switch head and provides a positively operated not easily defeatable interlock switch. When the guard is closed, the actuator inserted in the switch and the switch locked, the machine can be started. When the solenoid is energized (standard version of MKey9) the safety contacts are positively opened, and the guard door can be opened.

The MKey9 is available in two basic versions, either with a spring lock or an electro-magnetic lock. In the spring lock version, the locking mechanism moves into the locked position directly when the door is closed, and the actuator key is pushed into the switch. The actuator key can then only be released, and the gate opened, by supplying operational voltage to the solenoid (A1-A2).

MKey9M is the electro-magnetic lock variant, the locking mechanism is only in the locked position when the solenoid (A1-A2) is supplied with operating voltage. Release of the actuator key is only possible when the operating voltage is not applied to the solenoid (A1-A2). The solenoid voltage is 24VDC.

The MKey9 has double forced disconnection contacts connected to the actuator key and the locking mechanism. The actuator key is designed to prevent tampering with tools, magnets or similar objects. To achieve highest safety level in connection with the machine control system, it is recommended that the MKey9 is monitored by an appropriate ABB safety relay, Pluto safety PLC or Vital system. To obtain the highest level of safety, two switches per gate are required.

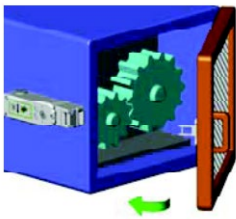

Hinged guard

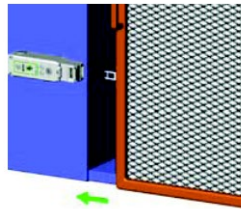

Sliding guard

Warning!

Application consideration must be given to the fixing of the actuator which has to be in a way that prevents disassembly by easy means.

The head can be set in four positions, thus providing the safety device with eight different operation positions. The leading edges of the actuator key are reinforced and beveled in order to guide it properly into the hole. The safety switch is designed to have a high holding force of 1800N. MKey9 has several types of actuators as options. A standard actuator key is always delivered with interlock switches.



NB: Top or side manual release points (not on MKey9M)

3 Connections

See Chapter 4 Installation and Maintenance for more information regarding installation.

Connections

MKey8/9 – Safety lock

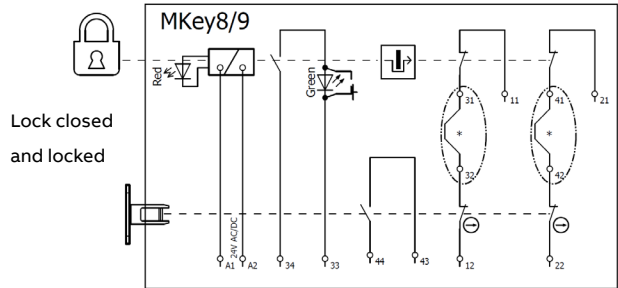
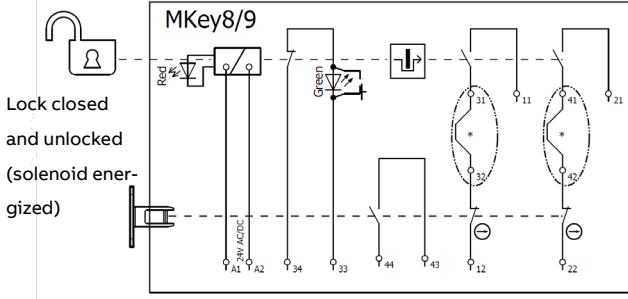

*These terminals are only present in the MKey8 models

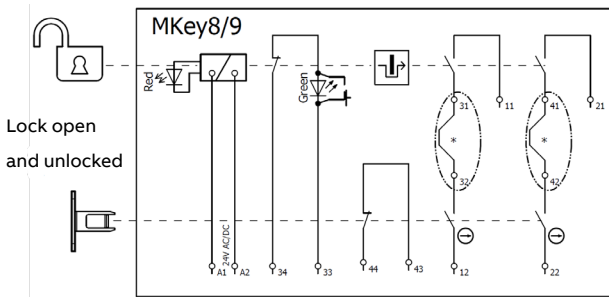

MKey8M/MKey9M – Process lock

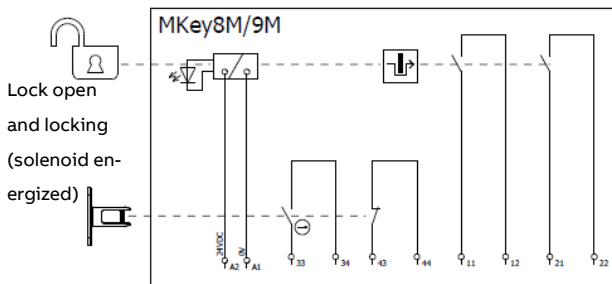
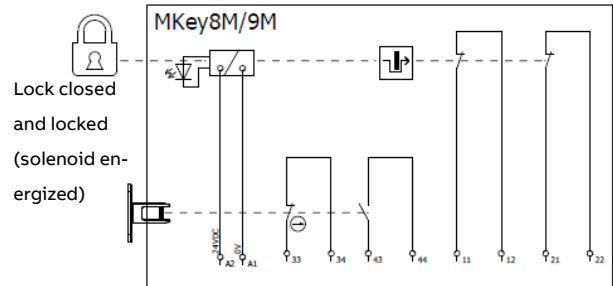
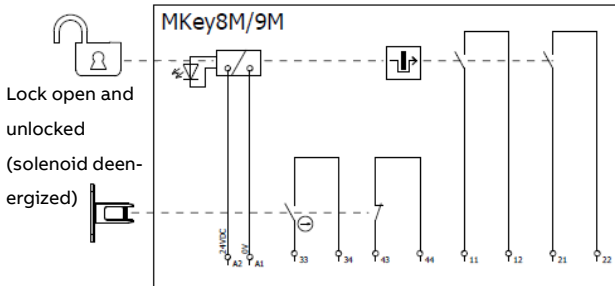

Key



Locking monitoring according to EN ISO 14119



Positive break normally closed contact

One LED is ON when the solenoid is supplied. This LED is green on the "Power to lock" models and red on the "Power to unlock" models.

For the "Power to unlock" MKey models, a second LED is available depending on the position of a slide switch under the lid. See "4 Installation and maintenance",

Actuator insertion

	6.0	5.0	0 mm
11/12	Open		
21/22	Open		
33/34			Open
43/44			Open

	6.0	5.0	0 mm
11/12	Open		Solenoid energised
21/22	Open		Solenoid energised
33/34	Open		Tongue Inserted
43/44		Open	Tongue Inserted

MKey9M, Contacts at withdrawal of actuator.

MKey9, Contacts at withdrawal of actuator.

NB! Measurements in mm

4 Installation and maintenance

Installation

1. The installation of all ABB safety interlock switches must be done in accordance with a risk assessment for the individual application. Installation must only be carried out by competent personnel and in accordance with these instructions.
2. M5 mounting bolts must be used to fix the switch and actuator; the tightening torque to ensure reliable fixing is 4.0 Nm. To prevent loosening of the switch after installation, always fix the M5 mounting bolts with a thread-locking compound or secure using self-locking nuts. Tightening torque for the lid screws, conduit entry plugs and cable glands must be 1.5 Nm to ensure IP seal.

Only use the correct size gland for the conduit entry and cable outside diameter.

Tightening torque for the connection terminal screws is 0,7 Nm, max conductor size is 1,0 mm². The switch head position can be selected by removing the actuator, loosening the four head bolts and then rotating the head to the position required. Re-tighten the head bolts and then check actuator insertion and withdrawal.

Tightening torque for the head bolts is 1.5Nm.

3. Always fit a mechanical stop to the guard to prevent damage to the front of the switch.

Set the actuator gap to 3 mm when the guard is closed and against the stop (see illustration).

Use alignment guides to ensure that the actuator enters the switch without interfering with the sides of the aperture.

Ensure access to at least one of the manual release points.

Always fit the aperture plug to the unused entry aperture to prevent debris entering the switch mechanism.

4. Always use the circuits 11-12 and 21-22 to ensure monitoring of the lock.

For the "power to unlock" models: Use the slide switch inside the switch housing to choose whether the green LED should be used or bypassed.

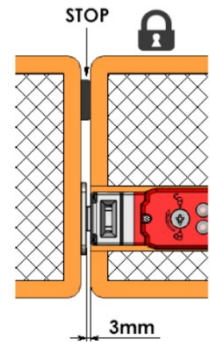

Position 1 (at delivery):

- The green LED is bypassed
- The terminals 33-34 can be used as a potential free auxiliary contact to indicate lock status (closed when unlocked)
- The slide switch is up, and no dot is visible on the white part.

Position 2:

- When supplied, the green LED will be ON when the guard is locked
- Apply 0 V to terminal 33 and +24 V DC to terminal 34
- The slide switch is down, and a dot is visible on the white part.

Caution! Make sure the Manual unlock function selector is in "Locked" position before putting the cover back on.

5. After installation check operation of all control circuits and the locking function. For applications with a run-down time after turning off power, ensure that the correct time delay has elapsed before energizing the solenoid.

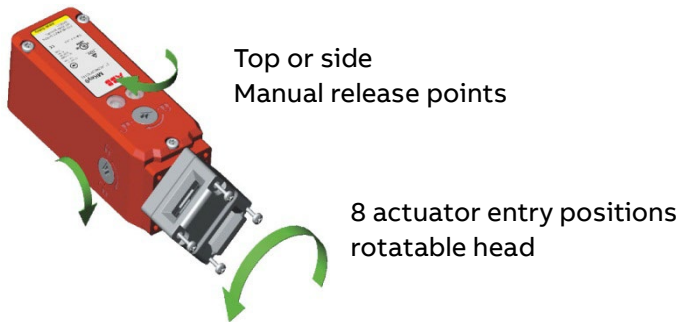

⚠ Warning! All the safety functions must be tested before starting up the system.

Maintenance

The recommendations below are general, and the frequency of the checks can be adapted to suit the history of use and the environment.

Every week: Check correct operation of all circuits. If the actuator shows signs of bending or the switch head housing displays mechanical damage, then remove and replace.

Every 6 months: Isolate power and remove cover. Check screw terminal tightness and check for signs of moisture ingress.

⚠ Warning! The safety functions and the mechanics shall be tested regularly, at least once every year to confirm that all the safety functions are working properly.

⚠ Warning! In case of breakdown or damage to the product, contact the nearest ABB Service Office or reseller. Do not try to repair the product yourself since it may accidentally cause permanent damage to the product, impairing the safety of the device which in turn could lead to serious injury to personnel.

Caution! ABB will not accept responsibility for failure of the switch functions if the installation and maintenance requirements shown in this sheet are not implemented. These requirements form part of the product warranty.

Caution! The switch solenoid is rated for continuous duty, and temperature rise will occur if left permanently energised. The temperature will not affect performance of the switch function, life time or damage the housing. As a precaution it is always advised to limit the energised time of the solenoid(not on MKey8M) and where possible and avoid mounting on sensitive surfaces (metal preferred).

Minimum safety distance

When using interlocking guards without guard locking to safeguard a hazard zone, the minimum allowed safety distance between the guarded opening and the hazardous machine must be calculated. In order to ensure that the hazardous machine motion will be stopped before it can be reached, the minimum safety distance is calculated according to EN ISO 13855 (“Positioning of safeguards with respect to the approach speeds of parts of the human body”).

The minimum safety distance is calculated according to the formula:

$$S = (K \times T) + C$$

Where

S = minimum safety distance (mm)

K = approach speed of a human body; 1600 mm/s

T = the total time from opening of the guard until the hazardous machine movement has stopped, i.e. including control system reaction times and other delays (s)

C = a safety distance taken from Table 4 or Table 5 of EN ISO 13857:2008, if it is possible to push fingers or a hand through the opening towards the hazard before a stop signal is generated

NB: In some cases, T might be reduced by the opening time of the guard until the opening size permits access of the relevant parts of the body. Refer to EN ISO 13855 for further details and EN ISO 13857 for specified values.

5 Functions

Manual unlock function (auxiliary release)

The manual unlock function (auxiliary release according to EN ISO 14119) is achieved by using a tool and is to be used in exceptional circumstances. The release can be protected by use of a tamper coating to prevent unintended operation. If operated, this tamper protection is damaged and must be restored to ensure protection.

6 Disassembly and disposal

Disassembly

The MKey interlock device must be disassembled in its de-energised state, no power.

Disposal

The MKey interlock device must be disposed of in accordance with the national legislation and regulation.

7 Model overview

Type	Article number	Description
MKey9	2TLA050007R0112	Spring lock, M20, 24VDC, Standard Key included
MKey9M	2TLA050009R0112	Electro-magnetic lock, M20, 24VDC, Standard Key included

Actuators

All keys are in stainless steel.

Type	Article number	Description
1	2TLA050040R0202	Standard key
2	2TLA050040R0220	Flat key
3	2TLA050040R0203	Flexible key with metal housing
4	2TLA050040R0204	Flexible key with stainless steel housing

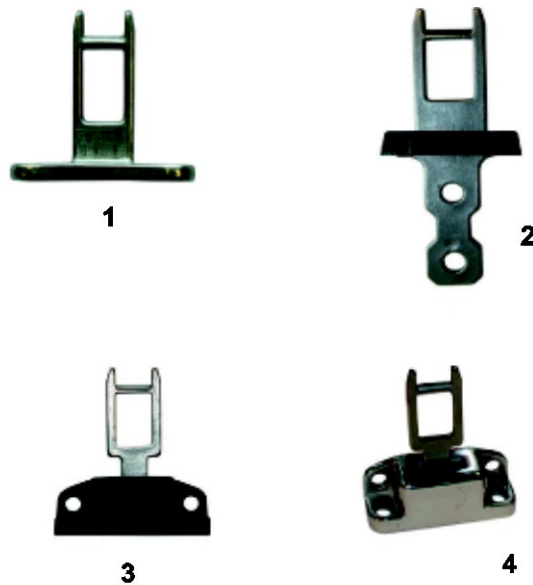

Accessories

Type	Article number	Description
Gland	2TLA050040R0002	Stainless steel cable gland M20 x 1.5
Lockout actuator	2TLA050040R0401	Lockable service key for maintenance
Slide Lock Left	2TLA050040R0500	Slide Lock for MKey8, 9 for left hinged door
Slide Lock Right	2TLA050040R0501	Slide Lock for MKey8, 9 for right hinged door
Rear Handle	2TLA050040R0510	Handle for inside operation for Slide Lock
Spring Catch	2TLA050040R0511	Spring loaded catch for Slide Lock

Dimensions

Slide Lock

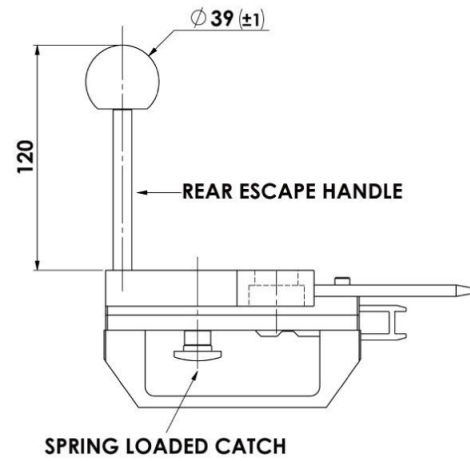
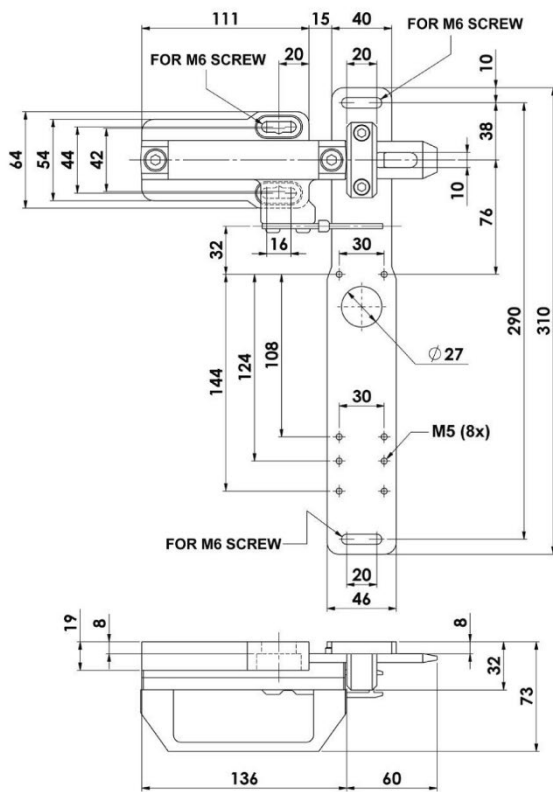

NB: All measurements in millimeters.

MKey9, MKey9M

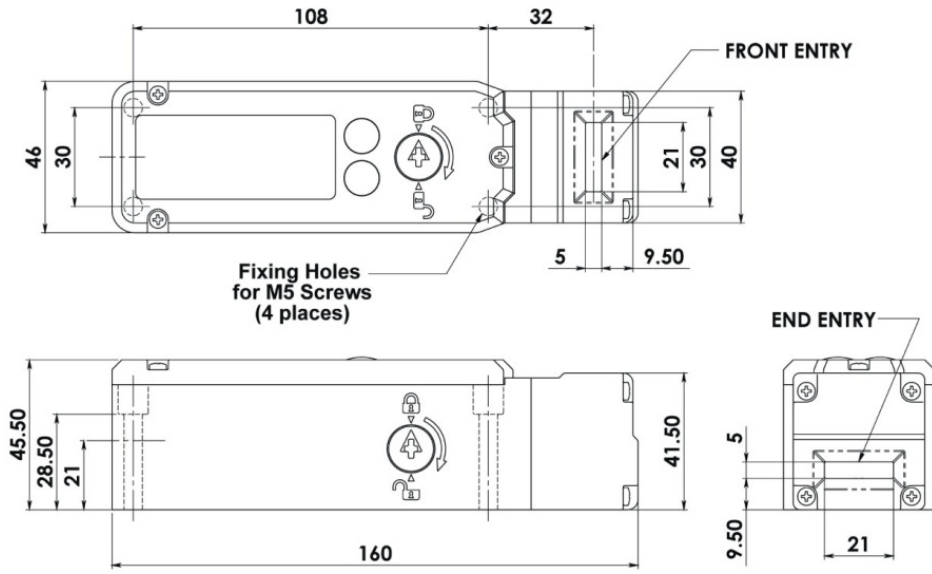

NB: All measurements in millimeters.

Actuators

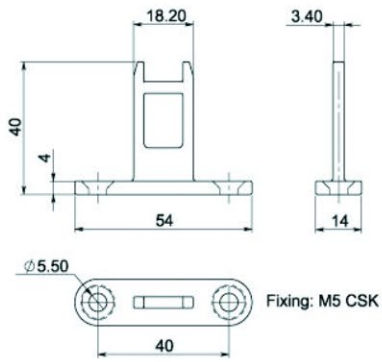

1

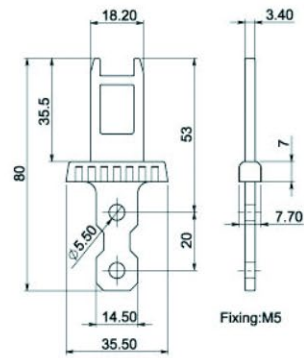

2

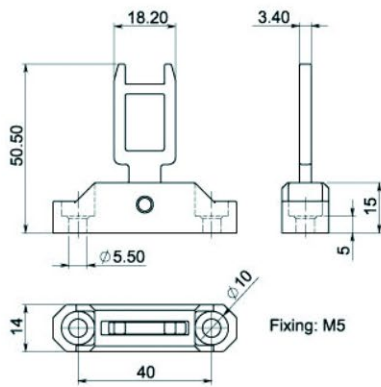

3

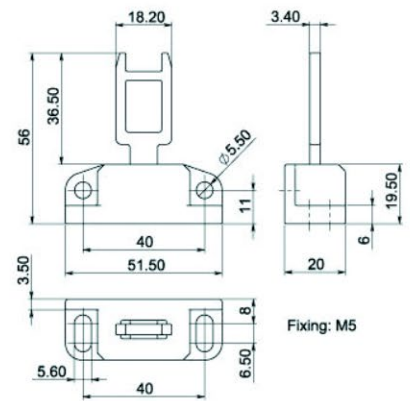

4

NB: All measurements in millimeters.

8 Technical data

Manufacturer

Address	ABB Electrification Sweden AB SE-721 61 Västerås Sweden
---------	---

Electrical characteristics

Utilization category	AC-15 A300 3 A
Thermal current	10 A
Rated insulation/withstand voltages	600 V AC/2500 V AC
LED 2 supply voltage	24 V DC +/-10%
Solenoid power consumption	12 W (MKey9M, inrush current 1.5 A)
Solenoid voltage	24 V DC +/-10%
Auxiliary Contact 33/34 (selectable with LED2)	24 V 200 mA max. (Not on MKey9M)
Auxiliary Contact 43/44	24 V 200 mA max.
Minimum current dry contact	3 mA @ 24 V DC, 10 mA @ 10 V DC

General

Travel for positive opening	10 mm
Actuation Frequency	2 cycle/sec
Insertion / Withdrawal force key	12 N max
Actuator entry minimum radius	175 mm Standard Key 100 mm Flexible Key
Protection class	IP67
Ambient temperature	MKey9: -25...+55°C MKey9M: -25...+40°C
Size	See drawing
Conduit entries	1 x M20 x 1.5
Material	Stainless steel 316/Glass filled Polyester
Fixing	Body: 4 x M5 Actuator: 2 x M5
Maximum approach / withdrawal speed	600 mm/s
Holding force	1800 N (Max.)
Vibration	IEC 68-2-6, 10-55 Hz+1 Hz, Excursion: 0.35 mm, 1 octave/min

Safety-related characteristic data and Conformity

Conformity	European Machinery Directive 2006/42/EC EN ISO 12100:2010, EN ISO 14119:2013, EN 60204-1:2018, EN 60947-5-1:2017
EN ISO 13849-1	Up to PL e, Cat. 4 depending on system architecture
EN 62061	Up to SIL3 depending on system architecture
Safety data	
B _{10D}	2,500,000 operations at 100 mA load
MTTF _d	356 years (8 cycles per hour / 24 hours per day / 365 days per year)
Proof test interval (Life)	35 years
Certifications	cULus
Information with regard to UL 508	Use 12AWG copper conductors only Electrical Rating: A300 48W5 Type 1 Enclosure Max. Switching Current / Volt / Amp: 120 V 6 A (720 VA break) PF 0.38, 240 V 3 A (720 VA break) PF 0.38

NB: A single switch can achieve PL c, category 1, according to EN ISO 13849-1 if used correctly with a safety controller. If a fault exclusion is applied according to EN ISO 14119, it is possible to reach PL d, category 3, with e.g. the Slide Lock combined with the MKey switch.

A single switch combined with a second interlocking switch, can reach PL e, category 4, if a fault exclusion is applied meeting the requirements of EN ISO 14119 and EN ISO 13849-1.

9 Declarations of conformity



EC Declaration of conformity

(according to 2006/42/EC, Annex 2A)

We ABB Electrification Sweden AB
SE-721 61 Västerås
Sweden declare that the safety components of ABB Electrification
Sweden AB manufacture with type designations and safety
functions as listed below, is in conformity with the Directives

2006/42/EC – Machinery
2014/30/EU – EMC
2011/65/EU – RoHS2 + 2015/863

Authorised to compile the technical
file ABB Electrification Sweden AB
SE-721 61 Västerås
Sweden

Product

Safety interlock switches

MKey5 MKey5+ MKey5+Z

MKey5Z

MKey8 MKeyER

MKey8M MKey8Z MKey 9

MKey9M

Used harmonized standards EN ISO 12100:2010, EN ISO 14119:2013

Other used standards EN 60947-5-1:2017, EN 60204-1:2018

Viktoria Sakar
R&D team lead Electronics and Software
Västerås 220823



Declaration of conformity

(according to 2008 No 1597)

We	ABB Electrification Sweden AB SE-721 61 Västerås Sweden	declare that the safety components of ABB Electrification Sweden AB manufacture with type designations and safety functions as listed below, is in conformity with UK Statutory Instruments (and their amendments)
		2008 No 1597 – Supply of Machinery (Safety) Regulations (MD) 2016 No. 1091 – Electromagnetic Compatibility Regulations (EMC) 2012 No 3032 – Restriction of the Use of Certain Hazardous Substances in Electrical and Electronic Equipment Regulations (RoHS)
Authorized representative		ABB Limited Tower Court Coventry CV6 5NX United Kingdom
Authorised to compile the technical file		ABB Limited Tower Court Coventry CV6 5NX United Kingdom
<u>Product</u>		
Safety interlock switches		
MKey5	MKey5+	MKey5+Z
MKey5Z		
MKey8	MKey8ER	
MKey8M	MKey8Z	MKey9
MKey9M		
Used designated standards		EN ISO 12100:2010, EN ISO 14119:2013, EN 60204-1:2018
Other used standards		EN 60947-5-1:2017

Magnus Backman
R&D Manager
Västerås 2022-02-25