

MODELLEN / MODELS / MODÈLES / MODELLE
2002SG

SPECIFICATIES / SPECIFICATIONS /
CARACTERISTIQUES / TECHNISCHE DATEN

	
wissel change over inverseur Wechsler 3A / 125V AC	-30°C ~ 70°C

IN DE DOOS / IN THE BOX / DANS LA BOÎTE / IN DER BOX

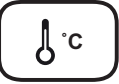
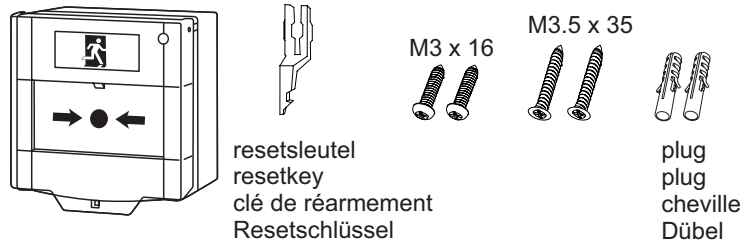

AANSLUITEN / WIRING / RACCORDEMENT / SCHALTBILDER

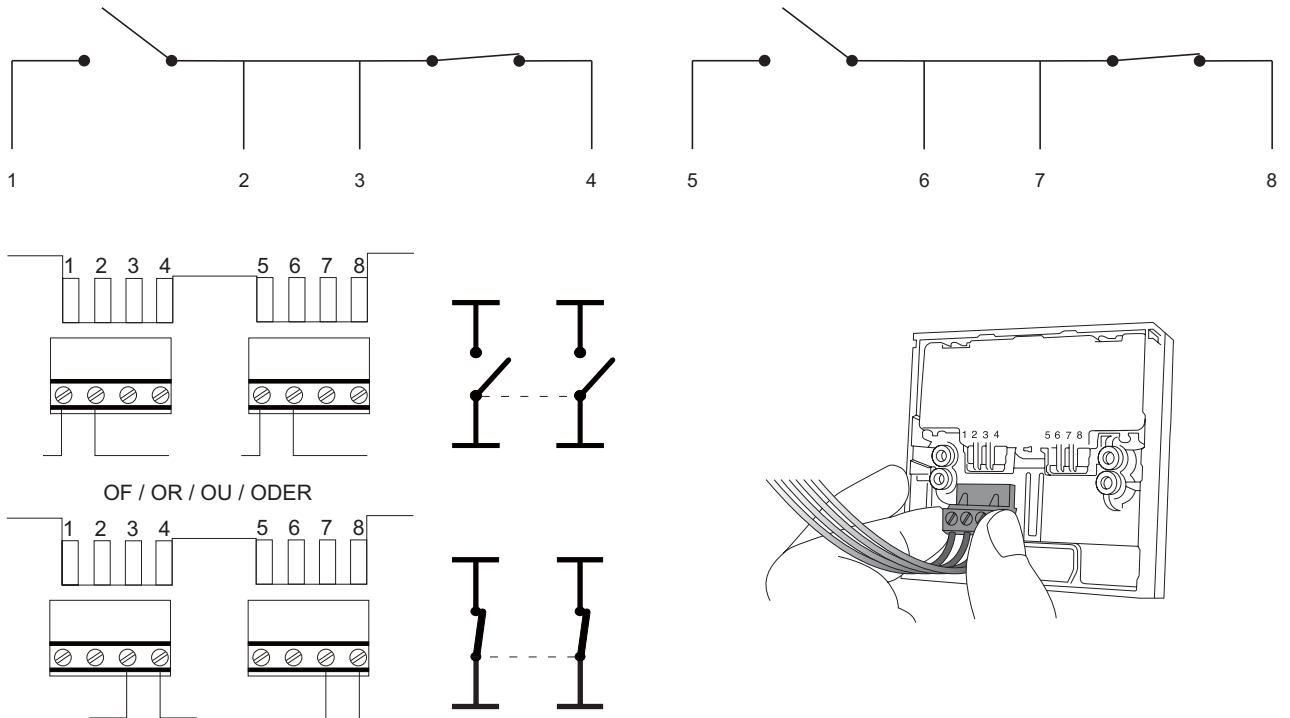

MAATVOERING / DIMENSIONS / DIMENSIONS / ABMESSUNGEN (MM)

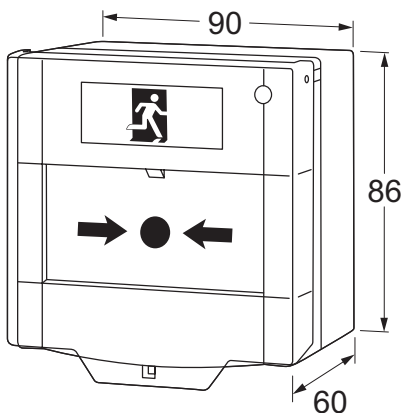

TESTEN OF RESETTEN / TEST OR RESET / TESTER OU RÉINITIALISER / TESTEN ODER ZURÜCKSETZEN

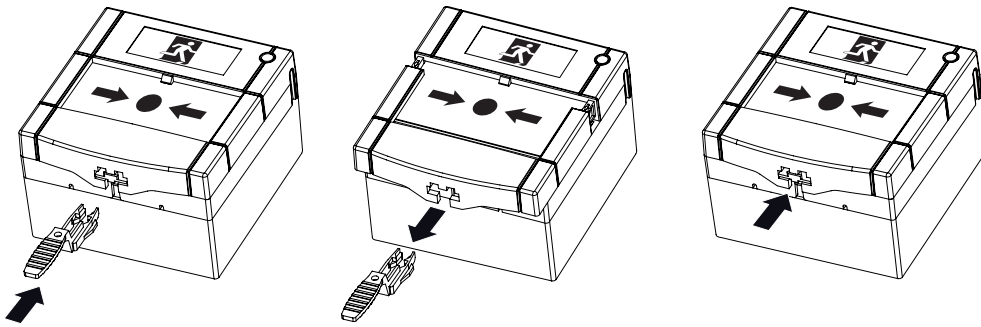

DRUKPLAATJE VERVANGEN / REPLACE PRESS PLATE /
REEMPLACER PLAQUE DE PRESSION / DRUCKPLATTE ERSETZEN

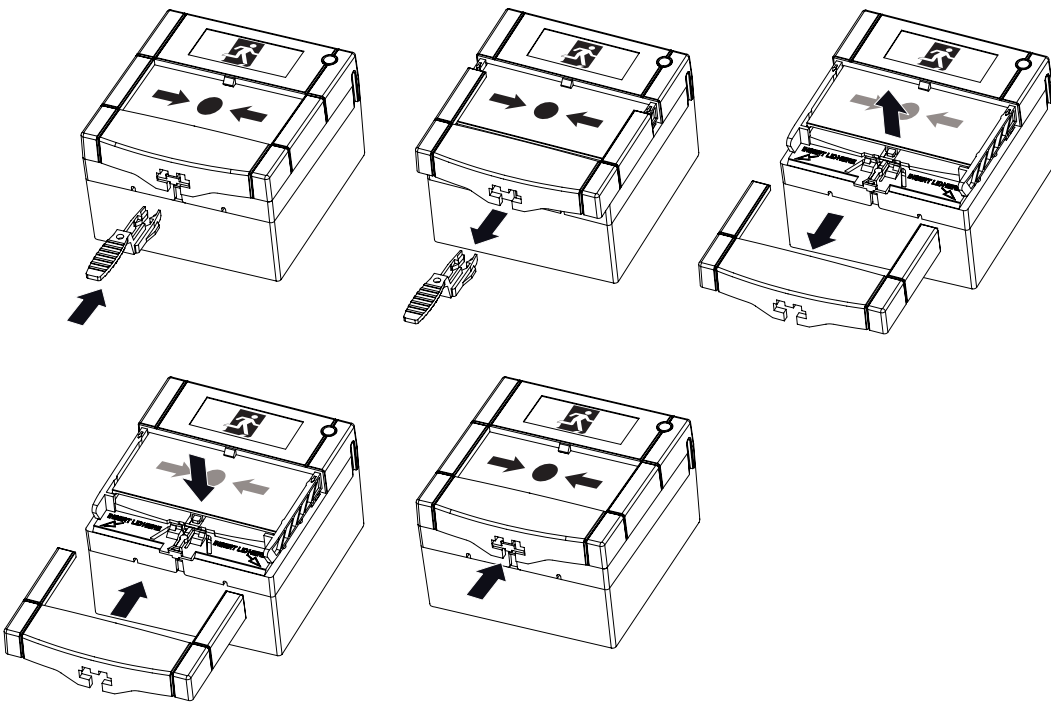

VOOR INSTALLATIE / BEFORE INSTALLATION / AVANT L'INSTALLATION / VOR DER INSTALLATION

Verwijder afdekkap voor installatie.
Remove protection cover before installation.
Enlevez le capot de protection avant l'installation.
Entfernen Sie die Abdeckkappe vor der Installation.

Voor inbouwdoos met schroefgaten op 60 mm.
For electric socket with screw holes at 60 mm.
Pour prise électrique avec trous de vis à 60 mm.
Für Gerätedose mit Schraublöchern auf 60 mm.

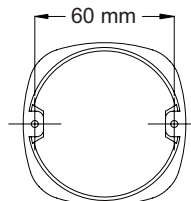
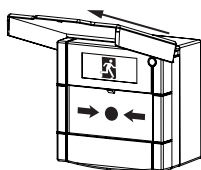

Montage complete handmelder.
Mounting complete manual call point.
Montage le déclencheur manuel complète.
Montage kompletter Handmelder.

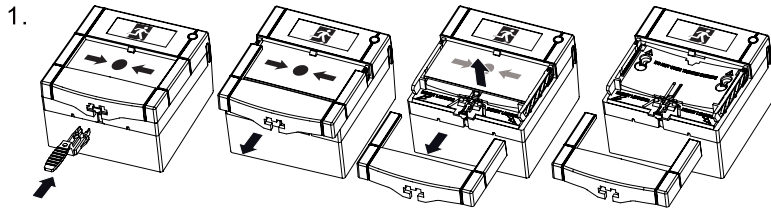
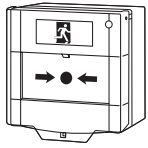

1. Verwijder onderste deel handmelder en witte drukplaatje.
Remove bottom part of call point and white press plate.
Retirer partie inférieure déclencheur manuel et plaque de pression blanche.
Entferne Unterteil Handmelder und weiße Druckplatte.

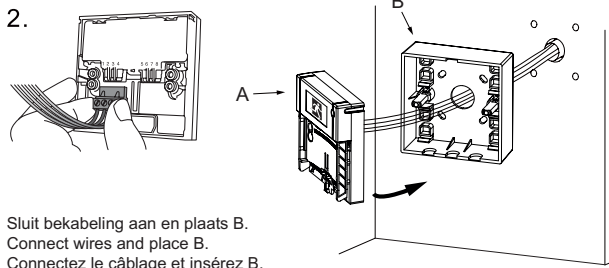

2. Sluit bekabeling aan en plaats B.
Connect wires and place B.
Connectez le câblage et insérez B.
Verbinden Sie die Verkabelung und stecken Sie B ein.

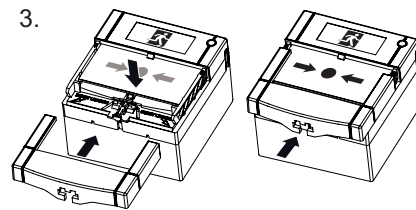

3. Plaats witte drukplaatje en onderste deel handmelder.
Place white press plate and bottom part of call point.
Placez plaque de pression blanche et partie inférieure déclencheur manuel.
Platzieren Sie weiße Druckplatte und Unterteil Handmelder.

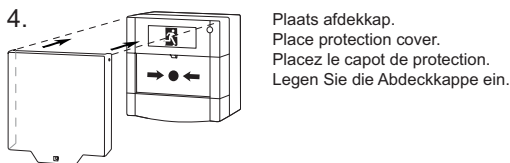

4. Plaats afdekkap.
Place protection cover.
Placez le capot de protection.
Legen Sie die Abdeckkappe ein.

Montage semi inbouw (zijaanzicht).
Mounting semi flush (side view).
Montage semi intégré (vue de côté).
Montage semi einbau (Seitenansicht).

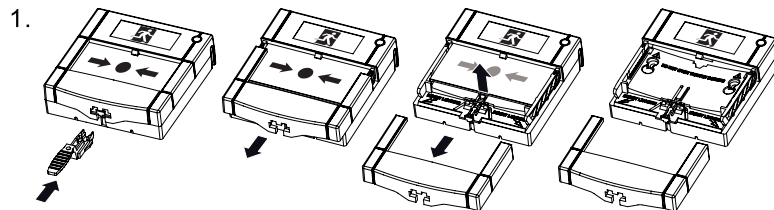

1. Verwijder onderste deel handmelder en witte drukplaatje.
Remove bottom part of call point and white press plate.
Retirer partie inférieure déclencheur manuel et plaque de pression blanche.
Entferne Unterteil Handmelder und weiße Druckplatte.

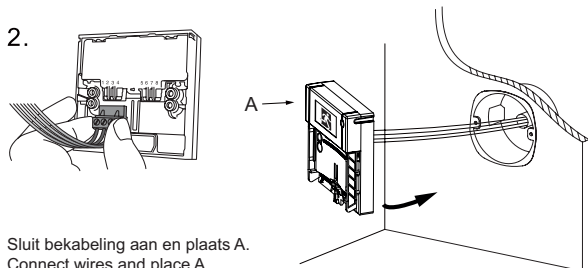

2. Sluit bekabeling aan en plaats A.
Connect wires and place A.
Connectez le câblage et insérez A.
Verbinden Sie die Verkabelung und stecken Sie A ein.

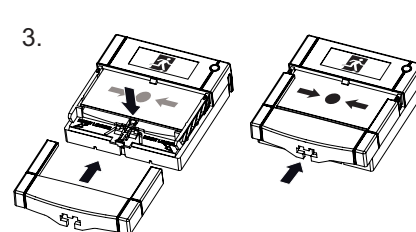

3. Plaats witte drukplaatje en onderste deel handmelder.
Place white press plate and bottom part of call point.
Placez plaque de pression blanche et partie inférieure déclencheur manuel.
Platzieren Sie weiße Druckplatte und Unterteil Handmelder.

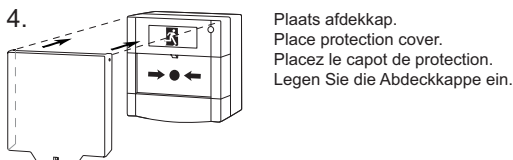

4. Plaats afdekkap.
Place protection cover.
Placez le capot de protection.
Legen Sie die Abdeckkappe ein.