

Product datasheet

Specifications

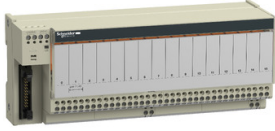

Sub-base with plug-in electromechanical relay ABE7 - 16 channels - relay 10 mm

Local distributor code:

402703468

ABE7R16T210

EAN Code: 3389110644630

Main

Range of product	Modicon ABE7
Product or component type	Sub-base with plug-in electromechanical relay
Sub-base type	Output sub-base
[Us] rated supply voltage	19...30 V conforming to IEC 61131-2
Number of channels	16

Complementary

supply voltage type	DC
Product compatibility	ABR7S21
Contacts type and composition	1 NO
Status LED	1 LED per channel (green) channel status 1 LED (green) power ON
Polarity distribution	Volt-free
Short-circuit protection	1 A internal fuse, 5 x 20 mm, fast blow (PLC end)
Fixing mode	By clips (35 mm symmetrical DIN rail) By screws (solid plate with fixing kit)
Maximum supply current	1 A
Voltage drop on power supply fuse	0.3 V
[U _i] rated insulation voltage	2000 V terminals/mounting rails 300 V coil circuit/contact circuits conforming to IEC 60947-1
[U _{imp}] rated impulse withstand voltage	2.5 kV
Installation category	II conforming to IEC 60664-1
Tightening torque	0.6 N.m with flat Ø 3.5 mm screwdriver
Net weight	0.735 kg

Environment

Product certifications	GL CSA UL DNV EAC
IP degree of protection	IP2X conforming to IEC 60529
Resistance to incandescent wire	750 °C conforming to IEC 60695-2-11
Shock resistance	15 gn for 11 ms conforming to IEC 60068-2-27
Vibration resistance	2 gn (f= 10...150 Hz) conforming to IEC 60068-2-6

Resistance to electrostatic discharge	4 kV (contact) level 3 conforming to IEC 61000-4-2 8 kV (air) level 3 conforming to IEC 61000-4-2
Resistance to radiated fields	10 V/m (26000000...1000000000 Hz) conforming to IEC 61000-4-3 level 3
Resistance to fast transients	2 kV level 3 conforming to IEC 61000-4-4
Ambient air temperature for operation	-5...60 °C conforming to IEC 61131-2
Ambient air temperature for storage	-40...80 °C conforming to IEC 61131-2
Pollution degree	2 conforming to IEC 60664-1

Packing Units

Unit Type of Package 1	PCE
Number of Units in Package 1	1
Package 1 Height	7.600 cm
Package 1 Width	9.600 cm
Package 1 Length	21.800 cm
Package 1 Weight	702.000 g
Unit Type of Package 2	S03
Number of Units in Package 2	12
Package 2 Height	30.000 cm
Package 2 Width	30.000 cm
Package 2 Length	40.000 cm
Package 2 Weight	8.926 kg

Logistical informations

Country of origin	LV
--------------------------	----

Contractual warranty

Warranty	18 months
-----------------	-----------



Environmental Data

Schneider Electric aims to achieve Net Zero status by 2050 through supply chain partnerships, lower impact materials, and circularity via our ongoing “Use Better, Use Longer, Use Again” campaign to extend product lifetimes and recyclability.

[Environmental Data explained >](#)

[How we assess product sustainability >](#)

Environmental footprint

Total lifecycle Carbon footprint 1041

Environmental Disclosure [Product Environmental Profile](#)

Use Better

Materials and Substances

Packaging made with recycled cardboard No

Packaging without single use plastic No

[EU RoHS Directive](#) Pro-active compliance (Product out of EU RoHS legal scope)

SCIP Number 4e5fc6c0-a6eb-485c-8b9b-e7290afe810f

REACH Regulation [REACH Declaration](#)

Use Again

Repack and remanufacture

End of life manual availability [End of Life Information](#)

Take-back No

WEEE Label  The product must be disposed on European Union markets following specific waste collection and never end up in rubbish bins

Dimensions Drawings

Dimensions

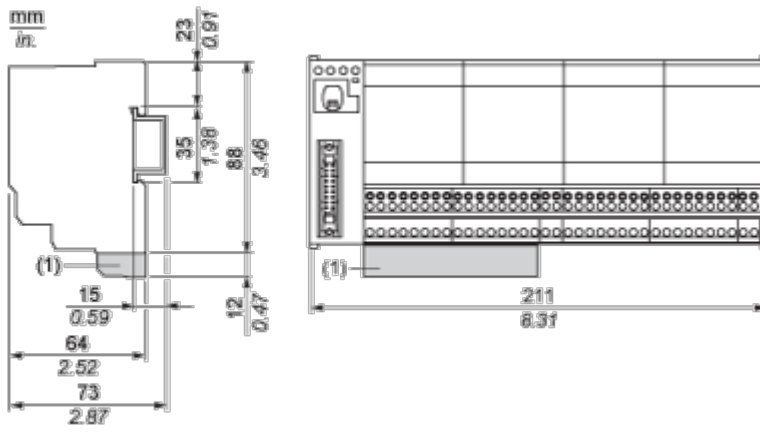

(1) ABE7BV10 / BV20, ABE7BV10E / BV20E

Mounting and Clearance

Mounting

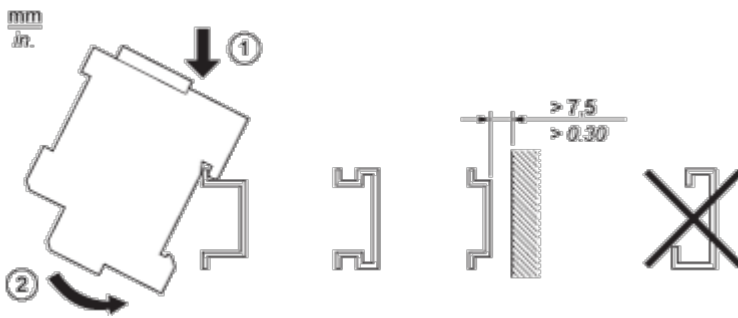

Connections and Schema

HE10 16 Channels

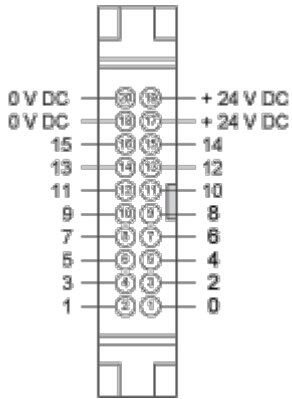

Wiring Diagram

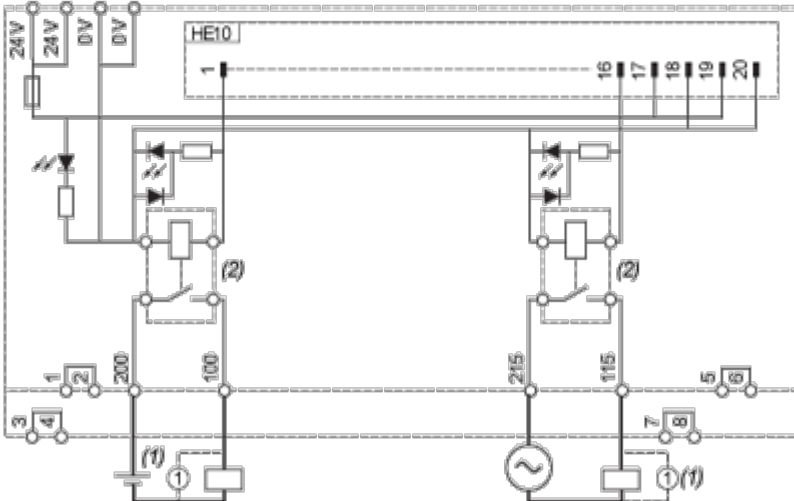

- (1) Inductive load
- (2) ABR7S21 (1 "F" "SPST") Ith = 5 A (supplied)

Performance Curves

Curves for Determining Cable Type and Length According to the Current

16-channel Sub-base

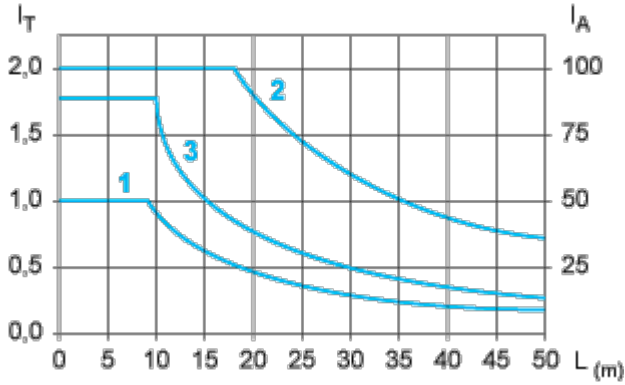

L Cable length

I_T Total current per sub base (A)

I_A Average current per channel (mA)

- (1) TSXCDP••2 and ABFH20H••0 cables with c.s.a. 0.08 mm² (AWG 28).
- (2) TSXCDP••3 cables with c.s.a. 0.34 mm² (AWG 22).
- (3) Cables with c.s.a. 0.13 mm² (AWG 26).

The curves are given for a voltage drop of 1 V in the cable. For n volts tolerance, multiply the length determined from the graph by n.

Temperature Derating Curves

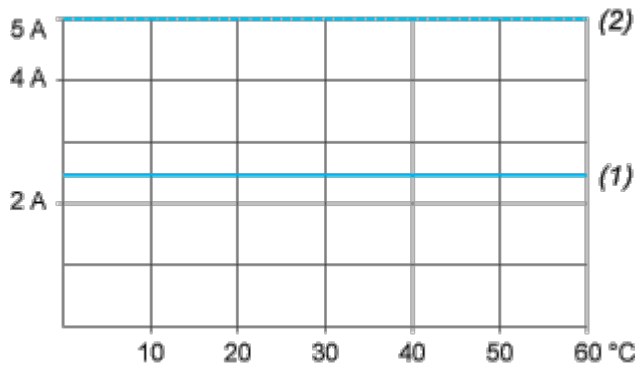

- (1) 100 % of channels used
- (2) 50 % of channels used

Electrical Durability (in Millions of Operating Cycles) Conforming to IEC 60947-5-1

DC Loads

DC12 curves

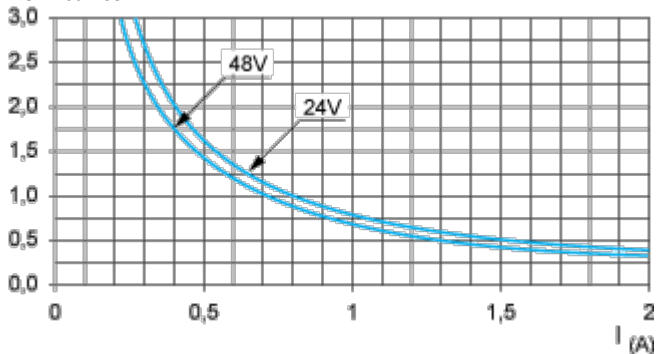

DC12 control of resistive loads and of solid state loads isolated by optocoupler, $L/R \leq 1$ ms.

DC13 curves

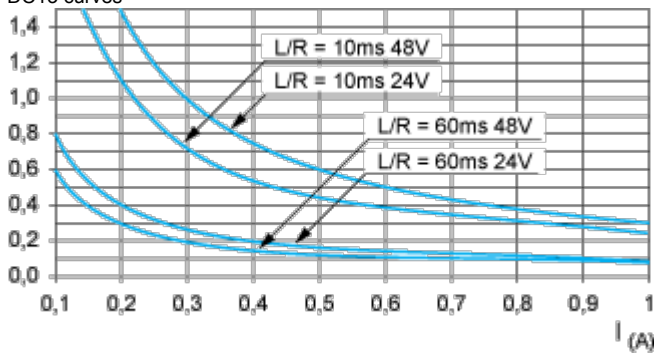

DC13 switching electromagnets, $L/R \leq 2 \times (U_e \times I_e)$ in ms, U_e : rated operational voltage, I_e : rated operational current (with a protective diode on the load, DC12 curves must be used with a coefficient of 0.9 applied to the number in millions of operating cycles)

AC Loads

AC12 curves

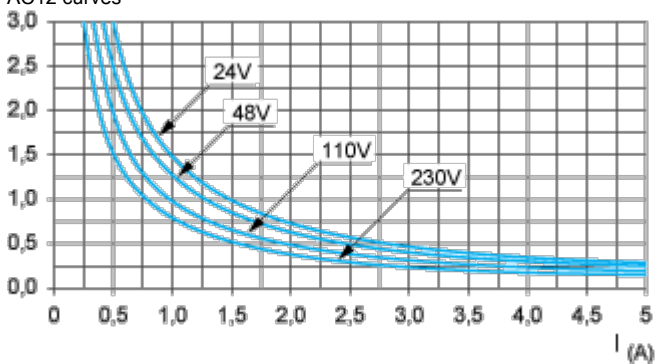

AC12 control of resistive loads and of solid state loads isolated by optocoupler, $\cos \phi \geq 0.9$.

AC14 curves

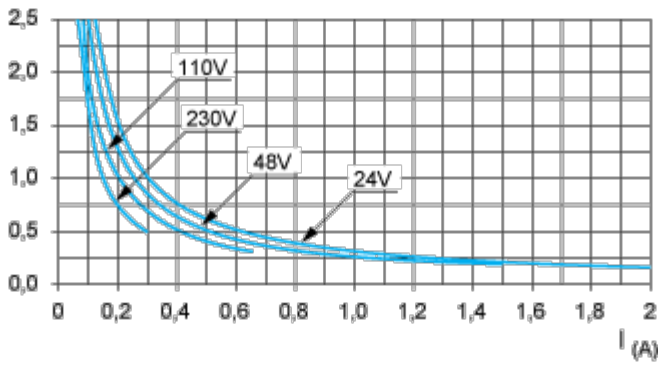

AC14 control of small electromagnetic loads ≤ 72 VA, make: $\cos \phi = 0.3$, break: $\cos \phi = 0.3$.

AC15 curves

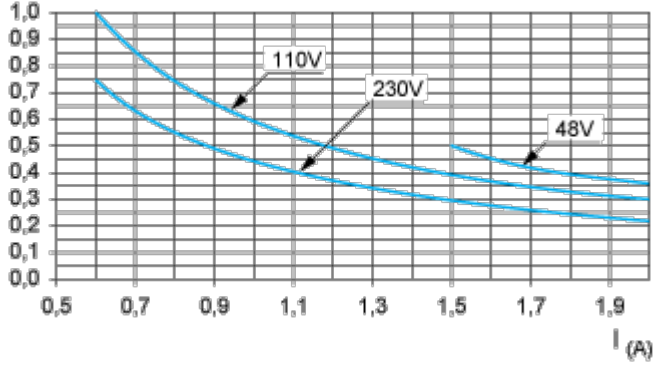

AC15 control of electromagnetic loads > 72 VA, make: $\cos \phi = 0.7$, break: $\cos \phi = 0.4$.

Image of product / Alternate images

Alternative

