

Product datasheet

Specifications



variable speed drive - 30kW- 400V - 3 phases - ATV340 Ethernet

Local distributor code:

408900650

ATV340D30N4E

EAN Code: 3606480967092

Main

Range of product	Altivar Machine ATV340
Product or component type	Variable speed drive
Product specific application	Machine
Mounting mode	Wall mount
Variant	Standard version
Communication port protocol	EtherNet/IP Modbus TCP Modbus serial
Option card	Communication module, PROFINET Communication module, DeviceNet Communication module, CANopen Communication module, EtherCAT
Network number of phases	3 phases
Supply frequency	50...60 Hz +/- 5 %
[Us] rated supply voltage	380...480 V - 15...10 %
Nominal output current	61.5 A
Motor power kW	37 kW for normal duty 30 kW for heavy duty
Motor power hp	50 hp for normal duty 40 hp for heavy duty
EMC filter	Class C3 EMC filter integrated
IP degree of protection	IP20
Degree of protection	UL type 1

Complementary

Discrete input number	8
Discrete input type	PTI safe torque off: 0...30 kHz, 24 V DC (30 V) DI1...DI5 programmable as pulse input, 24 V DC (30 V), impedance: 3.5 kOhm programmable
number of preset speeds	16 preset speeds
Discrete output number	1.0
Discrete output type	Programmable output DQ1, DQ2 30 V DC 100 mA
Analogue input number	3

Analogue input type	AI1 software-configurable current: 0...20 mA, impedance: 250 Ohm, resolution 12 bits AI1 software-configurable temperature probe or water level sensor AI1 software-configurable voltage: 0...10 V DC, impedance: 31.5 kOhm, resolution 12 bits AI2 software-configurable voltage: - 10...10 V DC, impedance: 31.5 kOhm, resolution 12 bits
Analogue output number	2
Analogue output type	Software-configurable voltage AQ1, AQ2: 0...10 V DC impedance 470 Ohm, resolution 10 bits Software-configurable current AQ1, AQ2: 0...20 mA impedance 500 Ohm, resolution 10 bits
Relay output number	3
Output voltage	<= power supply voltage
Relay output type	Relay outputs R1A Relay outputs R1C electrical durability 100000 cycles Relay outputs R2A Relay outputs R2C electrical durability 100000 cycles
Maximum switching current	Relay output R1C on resistive load, cos phi = 1: 3 A at 250 V AC Relay output R1C on resistive load, cos phi = 1: 3 A at 30 V DC Relay output R1C on inductive load, cos phi = 0.4 and L/R = 7 ms: 2 A at 250 V AC Relay output R1C on inductive load, cos phi = 0.4 and L/R = 7 ms: 2 A at 30 V DC Relay output R2C on resistive load, cos phi = 1: 5 A at 250 V AC Relay output R2C on resistive load, cos phi = 1: 5 A at 30 V DC Relay output R2C on inductive load, cos phi = 0.4 and L/R = 7 ms: 2 A at 250 V AC Relay output R2C on inductive load, cos phi = 0.4 and L/R = 7 ms: 2 A at 30 V DC
Minimum switching current	Relay output R1B: 5 mA at 24 V DC Relay output R2C: 5 mA at 24 V DC
Physical interface	2-wire RS 485
Connector type	3 RJ45
Method of access	Slave Modbus RTU Slave Modbus TCP
Transmission rate	4.8 kbit/s 9.6 kbit/s 19.2 kbit/s 38.4 kbit/s
Transmission frame	RTU
Number of addresses	1...247
Data format	8 bits, configurable odd, even or no parity
Type of polarization	No impedance
4 quadrant operation possible	True
Asynchronous motor control profile	Variable torque standard Optimized torque mode Constant torque standard
Synchronous motor control profile	Reluctance motor Permanent magnet motor
Pollution degree	2 conforming to IEC 61800-5-1
Maximum output frequency	0.599 kHz
Acceleration and deceleration ramps	Linear adjustable separately from 0.01...9999 s S, U or customized
Motor slip compensation	Automatic whatever the load Not available in permanent magnet motor law Adjustable Can be suppressed
Switching frequency	2...16 kHz adjustable 4...16 kHz with derating factor

Nominal switching frequency	4 kHz
Braking to standstill	By DC injection
Brake chopper integrated	True
Line current	66.2 A at 380 V (normal duty) 57.3 A at 480 V (normal duty) 54.8 A at 380 V (heavy duty) 48.3 A at 480 V (heavy duty)
Line current	66.2 A at 380 V with internal line choke (normal duty) 57.3 A at 480 V with internal line choke (normal duty) 66.2 A at 380 V with internal line choke (heavy duty) 57.3 A at 480 V with internal line choke (heavy duty) 54.8 A 48.3 A
Maximum input current	66.2 A
Maximum output voltage	480 V
Apparent power	47.6 kVA at 480 V (normal duty) 40.2 kVA at 480 V (heavy duty)
Maximum transient current	89.4 A during 60 s (normal duty) 89.4 A during 2 s (normal duty) 92.3 A during 60 s (heavy duty) 92.3 A during 2 s (heavy duty)
Electrical connection	Screw terminal, clamping capacity: 35...50 mm ² for line side Screw terminal, clamping capacity: 25...50 mm ² for DC bus Screw terminal, clamping capacity: 35...50 mm ² for motor Screw terminal, clamping capacity: 0.75...1.5 mm ² for control
Prospective line I_{sc}	50 kA
Base load current at high overload	61.5 A
Base load current at low overload	74.5 A
Power dissipation in W	Natural convection: 77 W at 380 V, switching frequency 4 kHz (heavy duty) Forced convection: 640 W at 380 V, switching frequency 4 kHz (heavy duty) Natural convection: 90 W at 380 V, switching frequency 4 kHz (normal duty) Forced convection: 796 W at 380 V, switching frequency 4 kHz (normal duty)
Electrical connection	Line side: screw terminal 35...50 mm ² /AWG 3...AWG 1 DC bus: screw terminal 25...50 mm ² /AWG 4...AWG 1 Motor: screw terminal 35...50 mm ² /AWG 3...AWG 1 Control: screw terminal 0.75...1.5 mm ² /AWG 18...AWG 16
With safety function Safely Limited Speed (SLS)	True
With safety function Safe brake management (SBC/SBT)	True
With safety function Safe Operating Stop (SOS)	False
With safety function Safe Position (SP)	False
With safety function Safe programmable logic	False
With safety function Safe Speed Monitor (SSM)	False
With safety function Safe Stop 1 (SS1)	True
With sft fct Safe Stop 2 (SS2)	False
With safety function Safe torque off (STO)	True
With safety function Safely Limited Position (SLP)	False
With safety function Safe Direction (SDI)	False

Protection type	Thermal protection: motor Safe torque off: motor Motor phase loss: motor Thermal protection: drive Safe torque off: drive Overheating: drive Overcurrent: drive Output overcurrent between motor phase and earth: drive Output overcurrent between motor phases: drive Short-circuit between motor phase and earth: drive Short-circuit between motor phases: drive Motor phase loss: drive DC Bus overvoltage: drive Line supply overvoltage: drive Line supply undervoltage: drive Input supply loss: drive Exceeding limit speed: drive Break on the control circuit: drive
Width	213.0 mm
Height	660.0 mm
Depth	262.0 mm
Net weight	27.9 kg
Continuous output current	74.5 A at 4 kHz for normal duty 61.5 A at 4 kHz for heavy duty

Environment

Operating altitude	<= 4800 m with current derating above 1000m
Operating position	Vertical +/- 10 degree
Product certifications	UL CSA TÜV EAC CTick
Marking	CE
Standards	IEC 61800-3 IEC 61800-5-1 IEC 60721-3 IEC 61508 IEC 13849-1 UL 618000-5-1 UL 508C IEC 61000-3-12
Maximum THDI	<48 % full load conforming to IEC 61000-3-12 <48 % 80 % load conforming to IEC 61000-3-12
Assembly style	With heat sink
Electromagnetic compatibility	Electrostatic discharge immunity test level 3 conforming to IEC 61000-4-2 Radiated radio-frequency electromagnetic field immunity test level 3 conforming to IEC 61000-4-3 Electrical fast transient/burst immunity test level 4 conforming to IEC 61000-4-4 1.2/50 µs - 8/20 µs surge immunity test level 3 conforming to IEC 61000-4-5 Conducted radio-frequency immunity test level 3 conforming to IEC 61000-4-6
Environmental class (during operation)	Class 3C3 according to IEC 60721-3-3 Class 3S3 according to IEC 60721-3-3
Maximum acceleration under shock impact (during operation)	150 m/s ² at 11 ms
Maximum acceleration under vibrational stress (during operation)	10 m/s ² at 13...200 Hz
Maximum deflection under vibratory load (during operation)	1.5 mm at 2...13 Hz
Permitted relative humidity (during operation)	Class 3K5 according to EN 60721-3
Volume of cooling air	240.0 m ³ /h

Type of cooling	Forced convection
Overvoltage category	Class III
Regulation loop	Adjustable PID regulator
Noise level	63.5 dB
Pollution degree	2
Ambient air transport temperature	-40...70 °C
Ambient air temperature for operation	-15...50 °C without derating (vertical position) 50...60 °C with derating factor (vertical position)
Ambient air temperature for storage	-40...70 °C
Isolation	Between power and control terminals

Packing Units

Unit Type of Package 1	PCE
Number of Units in Package 1	1
Package 1 Height	55.000 cm
Package 1 Width	34.000 cm
Package 1 Length	84.000 cm
Package 1 Weight	35.000 kg

Contractual warranty

Warranty	18 months
----------	-----------



Environmental Data

Schneider Electric aims to achieve Net Zero status by 2050 through supply chain partnerships, lower impact materials, and circularity via our ongoing “Use Better, Use Longer, Use Again” campaign to extend product lifetimes and recyclability.

[Environmental Data explained >](#)

[How we assess product sustainability >](#)

Environmental footprint

Total lifecycle Carbon footprint 23531

Environmental Disclosure [Product Environmental Profile](#)

Use Better

Materials and Substances

Packaging made with recycled cardboard Yes

Packaging without single use plastic No

[EU RoHS Directive](#) Pro-active compliance (Product out of EU RoHS legal scope)

SCIP Number 8ac43dc1-9e7e-4e1a-a3ee-665587b07cd7

REACH Regulation [REACH Declaration](#)

Energy efficiency

Product contributes to saved and avoided emissions Yes

Use Again

Repack and remanufacture

End of life manual availability [End of Life Information](#)

Take-back No

WEEE Label  The product must be disposed on European Union markets following specific waste collection and never end up in rubbish bins

Dimensions Drawings

Dimensions

Views: Front - Left - Rear

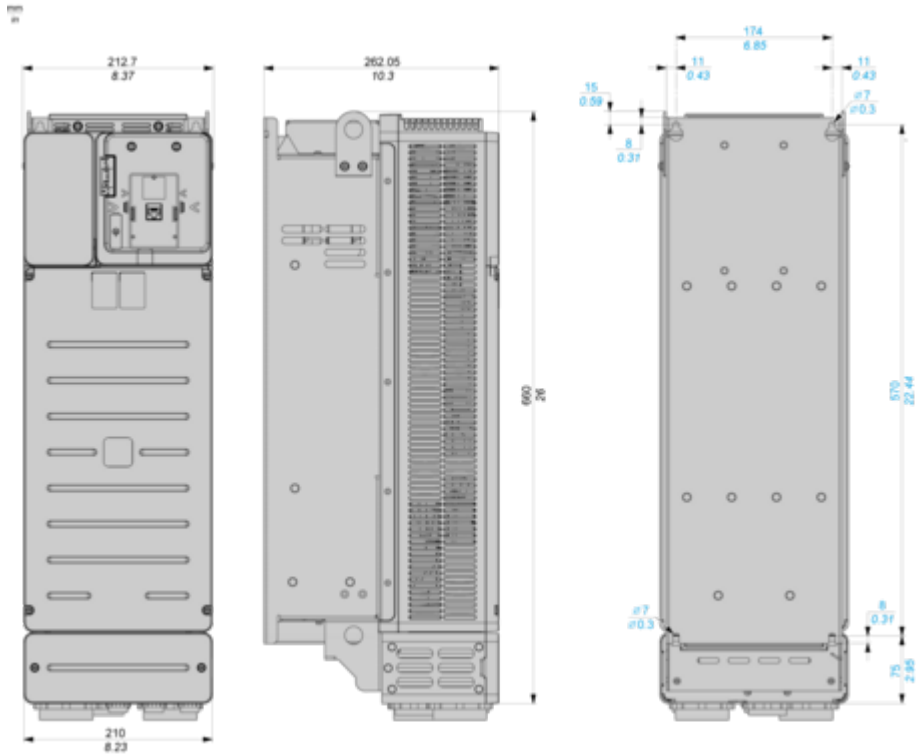

Mounting and Clearance

Clearance

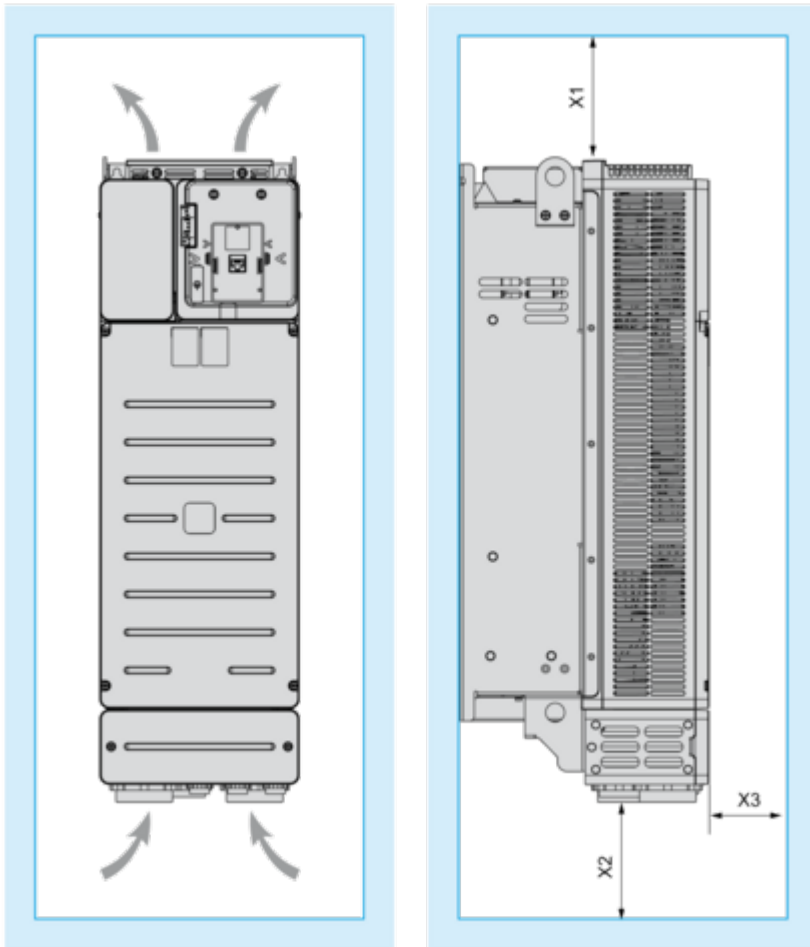

X1	X2	X3			
mm	in.	mm	in.	mm	in.
≥ 100	≥ 3.94	≥ 100	≥ 3.94	≥ 10	≥ 0.39

Mounting Types

Mounting Type A: Side by Side IP20

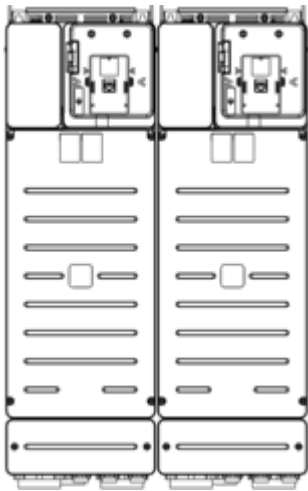

Possible, up to 50 °C, 2 drives only

Mounting Type B: Individual IP20

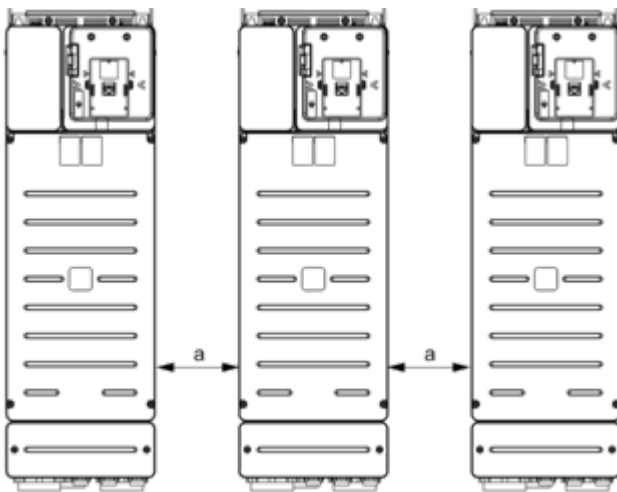

$a \geq 110 \text{ mm (4.33 in.)}$

Connections and Schema

Connections and Schema

Three-phase Power Supply - Diagram With Line Contactor

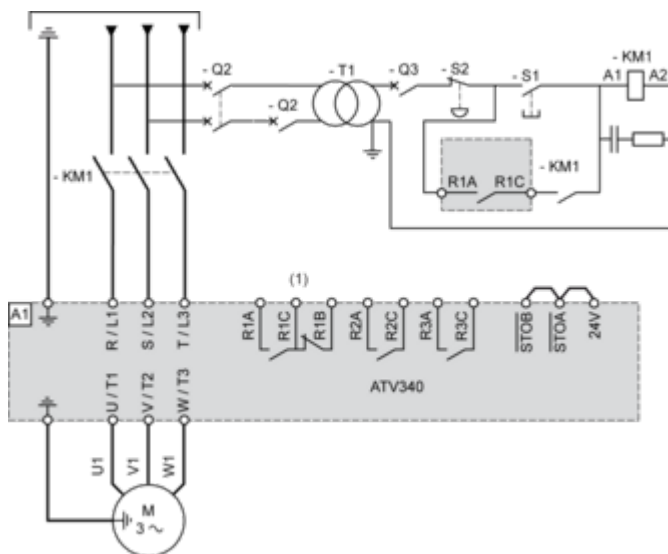

(1) : Use relay output R1 set to operating state Fault to switch Off the product once an error is detected.

NOTE :

- Press S1 until the initialization of the drive is finished.
- An external 24V power supply can be connected so that the control part of the drive is always power supplied.

Three-phase Power Supply - Diagram With Downstream Contactor

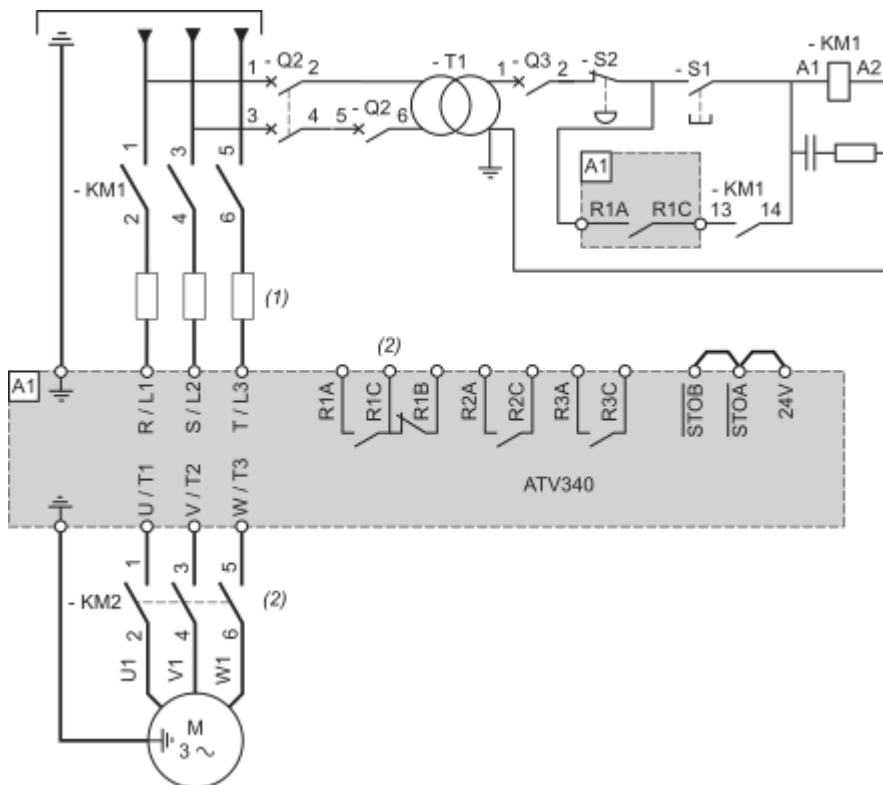

(1) : Use relay output R1 set to operating state Fault to switch Off the product once an error is detected.

(2) : Command of KM2 can be done by using the [Output contactor cmd] OCC function. For more information, refer to the programming manual.

NOTE :

- Close upstream contactor, then press S1 after the initialization of the drive is finished.
- An external 24V power supply can be connected so that the control part of the drive is always power supplied.

Sensor Connection

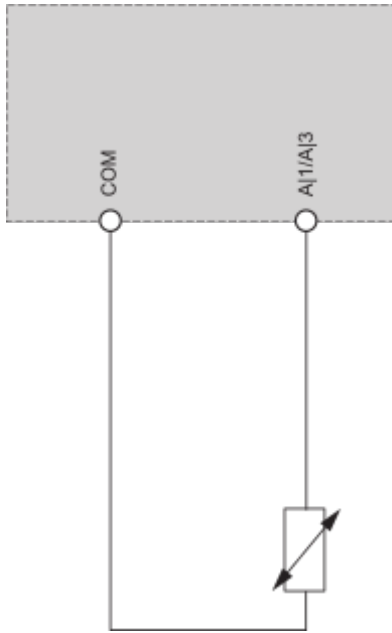

Control Block Wiring Diagram

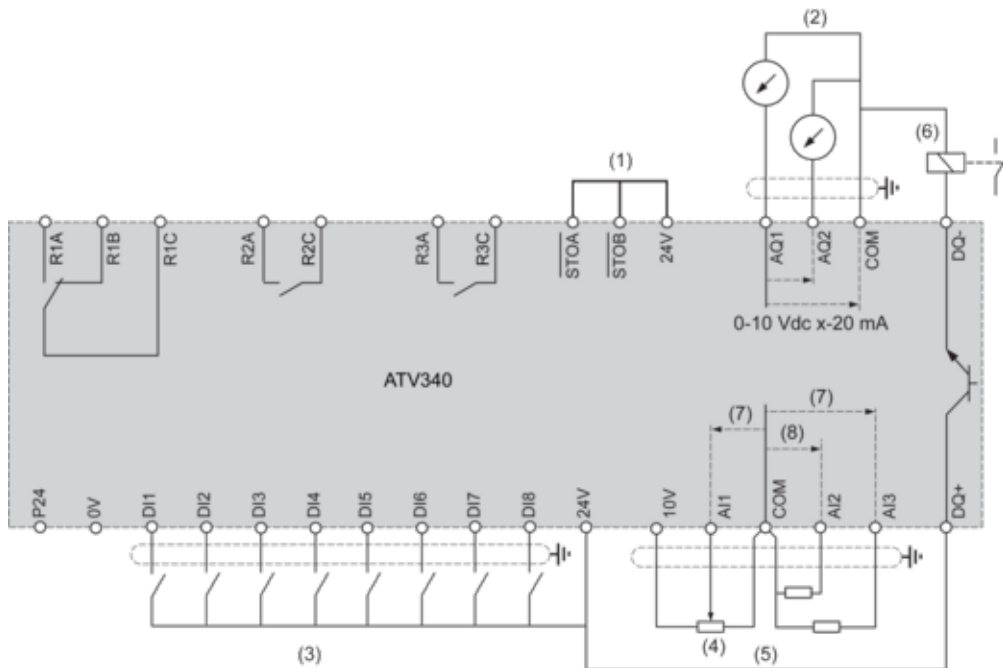

- (1) : STO Safe Torque Off
 - (2) : Analog Output
 - (3) : Digital Input - Shielding instructions are given in the Electromagnetic Compatibility section
 - (4) : Reference potentiometer (ex. SZ1RV1002)
 - (5) : Analog Input
 - (6) : Digital output
 - (7) : 0-10 Vdc, x-20 mA
 - (8) : 0-10 Vdc, -10 Vdc...+10 Vdc
- NOTE** : PTI function is not available on frame sizes 4 and 5.

Digital Inputs Wiring

Switch Set to SRC (Source) Position Using the Output Power Supply for the Digital Inputs

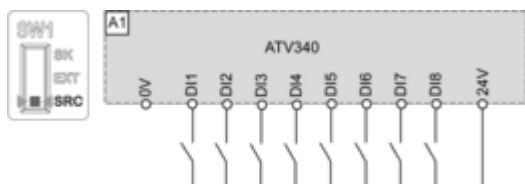

Switch Set to SRC (Source) Position and Use of an External Power Supply for the DIs

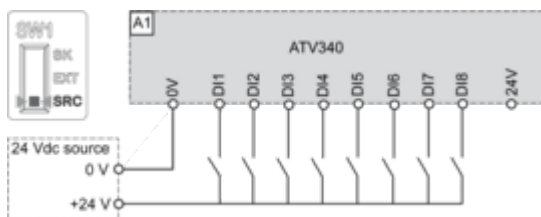

Switch Set to SK (Sink) Position Using the Output Power Supply for the Digital Inputs

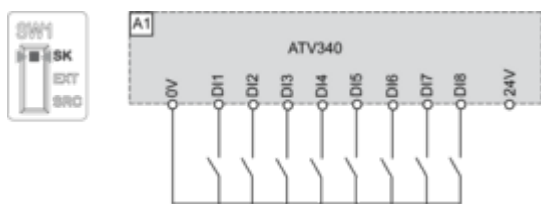

Switch Set to EXT Position Using an External Power Supply for the DIs

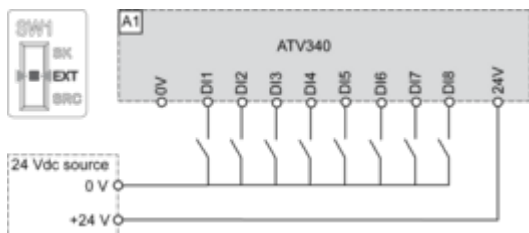

Digital Outputs Wiring

Digital Outputs: Internal Supply

Positive Logic, Source, European Style, DQ switches to +24V

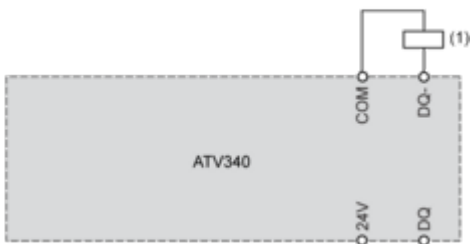

(1) Relay or valve

Negative Logic, Sink, Asian Style, DQ switches to 0V

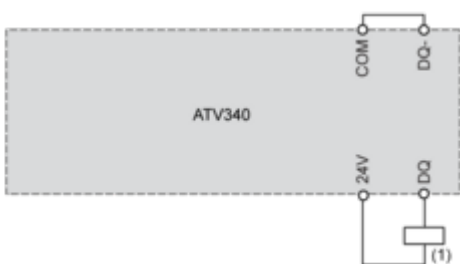

(1) Relay or valve

Digital Outputs: External Supply

Positive Logic, Source, European Style, DQ switches to +24V

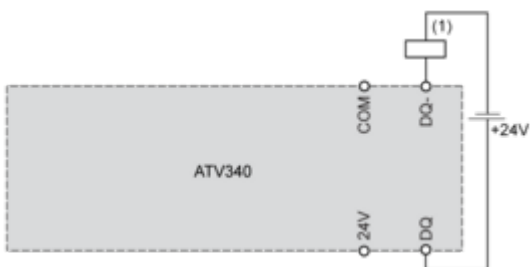

(1) Relay or valve

Negative Logic, Sink, Asian Style, DQ switches to 0V

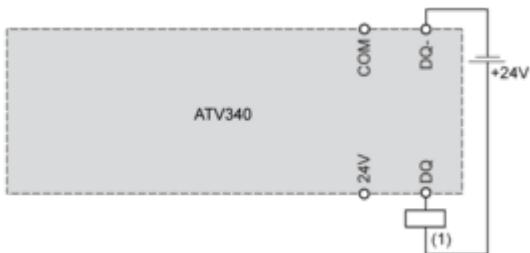

(1) Relay or valve

Performance Curves

Derating Curves

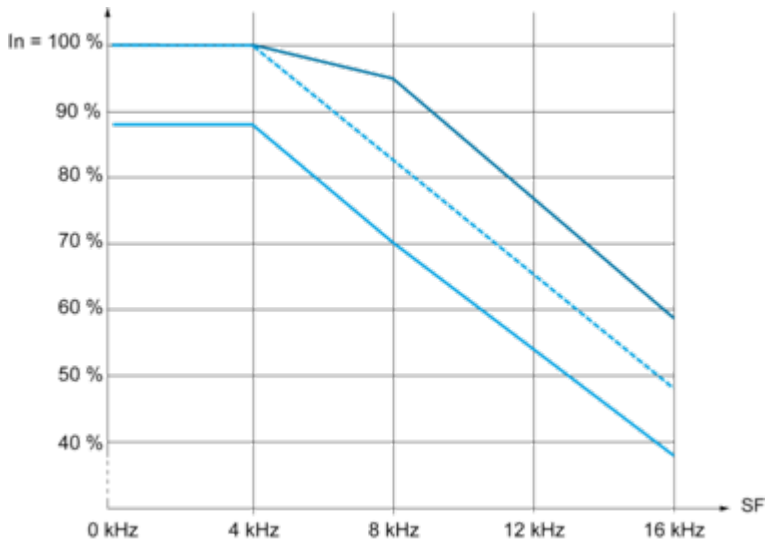

- 40 °C (104 °F) - Mounting type A and B
- - - 50 °C (122 °F) - Mounting type A and B
- 60 °C (140 °F) - Mounting type B

In : Nominal Drive Current
SF : Switching Frequency

Technical Illustration

Dimensions

