

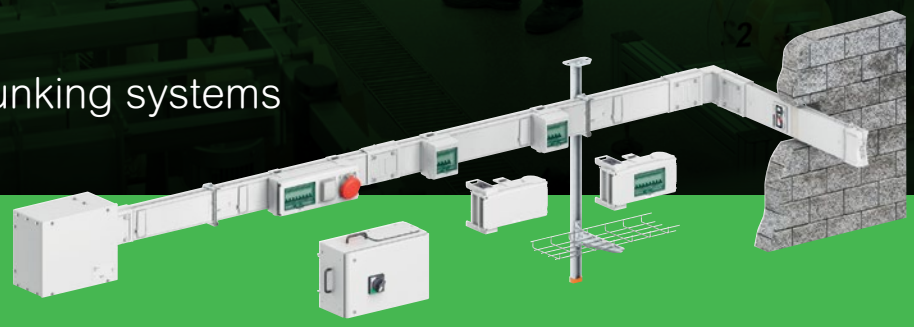

Canalis KSA 100-1000 A

Catalogue 2025
Prefabricated busbar trunking systems
Aluminium



se.com

Life Is On





Environmental Data Program

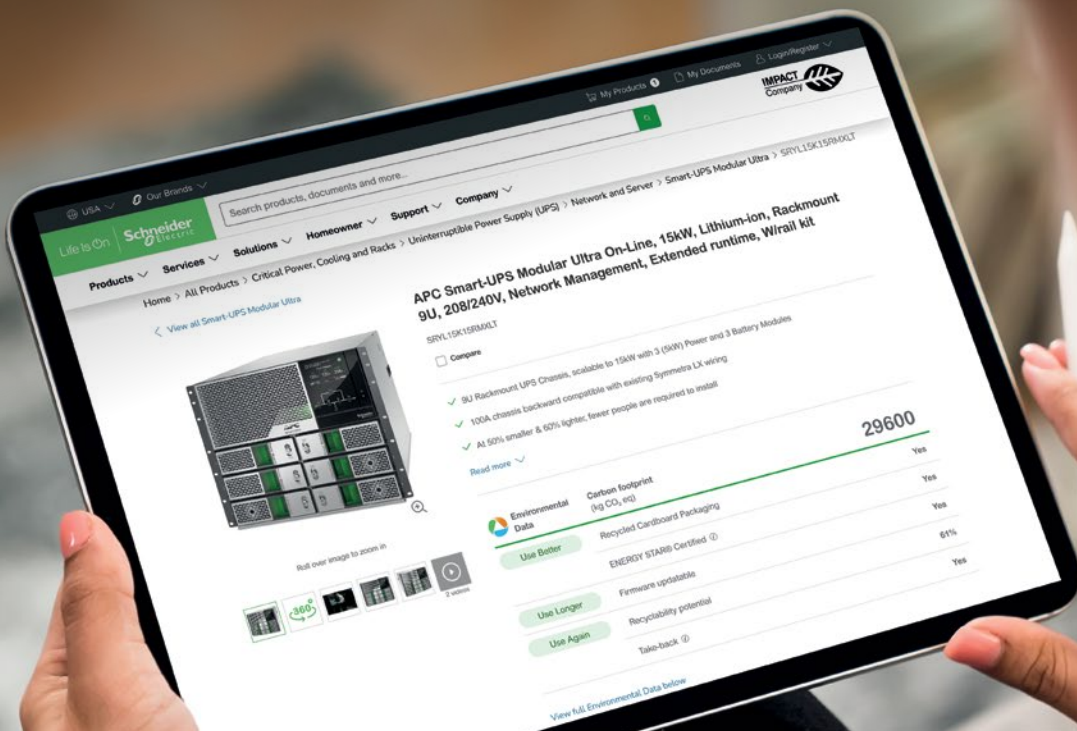

Next-level transparency for better-informed product choices

The Environmental Data Program is a framework for how we measure, categorize, and compare the environmental attributes and footprint of our products.

Using a rigorous, fact-based methodology, the program provides environmental data from across the product lifecycle.

Five data categories across the product lifecycle

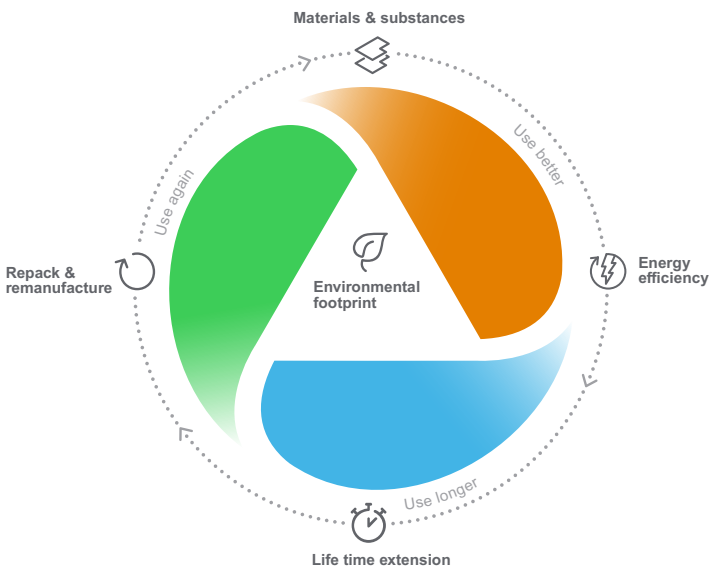

Use Better: How sustainable a product is, including environmental footprint, materials and substances, packaging, and energy efficiency.

Use Longer: How a product's life time can be effectively extended in terms of reparability and updatability.

Use Again: How a product can be reused, from dismantling and remanufacturing to recyclability and manufacturer take back.

With this transparent, verified data, customers and partners are empowered to make conscious environmental choices and accurately evaluate and report on sustainability performance.

All our hardware offers have an associated environmental data available on se.com product pages.



Learn more about the **Environmental Data Program**

General content

Canalis KSA

Index Index catalogue numbers	p. 4	A
Presentation	p. 6	B
Canalis ranges Panorama and KSA presentation	p. 14	C
Canalis KS Classic offer	p. 24	D
Canalis KS Advanced offer	p. 68	E
Canalis KS Rising main offer	p. 170	F
Canalis KS Missing link offer (Express delivery)	p. 188	G
Simplified study & design guide	p. 198	H
Characteristics and recommendations	p. 206	I

Index

Index catalogue numbers

Cat. no.	Pages	Cat. no.	Pages	Cat. no.	Pages	Cat. no.	Pages
KFB		KSA		KSA250DLF41F		KSA400ABCB4	
KFBCA81200	47, 182	KSA1000DTC40	150	KSA250DLF42A	102	KSA400ABDD4	80, 175
KFBCA81300	47	KSA1000DXC40	151	KSA250DLF42F	103	KSA400ABDD5	81, 176
KSA		KSA1000DZCG41A	122	KSA250DLF43A	104	KSA400ABGD4	82
KSA1000ABD4	34, 174	KSA1000DZCG41F	123	KSA250DLF43B	120	KSA400ABGD5	83
KSA1000ABDD4	80, 175	KSA1000DZCG43A	124	KSA250DLF43F	105	KSA400ABT4	36
KSA1000ABDD5	81, 176	KSA1000DZCG43F	125	KSA250DLF4AM	194	KSA400ABTZFL21	87
KSA1000ABG4	35	KSA1000DZCH41A	126	KSA250DLF4CFM	195	KSA400ABZFL21	86
KSA1000ABGD4	82	KSA1000DZCH41F	127	KSA250DLL41A	112	KSA400AE4	84, 177
KSA1000ABGD5	83	KSA1000DZCH43A	128	KSA250DLL41F	113	KSA400AF1	64
KSA1000ABT4	36	KSA1000DZCH43F	129	KSA250DLL42A	114	KSA400CM4A	181
KSA1000ABTZFL21	87	KSA1000DZE41A	130	KSA250DLL42F	115	KSA400CM4AF	181
KSA1000ABZFL21	86	KSA1000DZE41F	131	KSA250DLR41A	106	KSA400DLC401	42
KSA1000AE4	84, 177	KSA1000DZE43A	132	KSA250DLR41F	107	KSA400DLC43B	118
KSA1000AF1	64	KSA1000DZE43F	133	KSA250DLR42A	108	KSA400DLC4AM	191
KSA1000CM4A	181	KSA1000ED4081	178	KSA250DLR42F	109	KSA400DLC4CFM	191
KSA1000CM4AF	181	KSA1000ED4154	88	KSA250DLR43A	110, 116	KSA400DLE401	43
KSA1000DLC401	42	KSA1000ED4206	88	KSA250DLR43F	111, 117	KSA400DLE41A	94
KSA1000DLC43B	118	KSA1000ED4306	38	KSA250DMBK41A	142	KSA400DLE41F	95
KSA1000DLC4AM	191	KSA1000ED45010	39	KSA250DMBK41F	143	KSA400DLE42A	96
KSA1000DLC4CFM	191	KSA1000ET430	90	KSA250DMBK43A	144	KSA400DLE42F	97
KSA1000DLE401	43	KSA1000ET43A	92	KSA250DMBK43F	145	KSA400DLE43A	98
KSA1000DLE41A	94	KSA1000ET43AF	92	KSA250DMBL41A	134	KSA400DLE43B	119
KSA1000DLE41F	95	KSA1000ET450	91	KSA250DMBL41F	135	KSA400DLE43F	99
KSA1000DLE42A	96	KSA1000ET4AFM	190	KSA250DMBL43A	136	KSA400DLE4AM	192
KSA1000DLE42F	97	KSA1000ET4AM	190	KSA250DMBL43F	137	KSA400DLE4CFM	193
KSA1000DLE43A	98	KSA1000EV4153	178	KSA250DMCK41A	146	KSA400DLF401	44
KSA1000DLE43B	119	KSA1000EV4203	179	KSA250DMCK41F	147	KSA400DLF41A	100
KSA1000DLE43F	99	KSA1000EV4254	180	KSA250DMCK43A	148	KSA400DLF41F	101
KSA1000DLE4AM	192	KSA1000ZJ4	65	KSA250DMCK43F	149	KSA400DLF42A	102
KSA1000DLE4CFM	193	KSA100AB4	34-35, 174	KSA250DMCL41A	138	KSA400DLF42F	103
KSA1000DLF401	44	KSA100ED4081	178	KSA250DMCL41F	139	KSA400DLF43A	104
KSA1000DLF41A	100	KSA100ED43012	40	KSA250DMCL43A	140	KSA400DLF43B	120
KSA1000DLF41F	101	KSA100ED4306	38	KSA250DMCL43F	141	KSA400DLF43F	105
KSA1000DLF42A	102	KSA100ED45010	39	KSA250DTC40	150	KSA400DLF4AM	194
KSA1000DLF42F	103	KSA100ED45020	41	KSA250DXC40	151	KSA400DLF4CFM	195
KSA1000DLF43A	104	KSA100EV4203	179	KSA250DZCG41A	122	KSA400DLL41A	112
KSA1000DLF43B	120	KSA100EV4254	180	KSA250DZCG41F	123	KSA400DLL41F	113
KSA1000DLF43F	105	KSA160ED43012	40	KSA250DZCG43A	124	KSA400DLL42A	114
KSA1000DLF4AM	194	KSA160ED4306	38	KSA250DZCG43F	125	KSA400DLL42F	115
KSA1000DLF4CFM	195	KSA160ED45010	39	KSA250DZCH41A	126	KSA400DLR41A	106
KSA1000DLL41A	112	KSA160ED45020	41	KSA250DZCH41F	127	KSA400DLR41F	107
KSA1000DLL41F	113	KSA250AB4	34-35, 174	KSA250DZCH43A	128	KSA400DLR42A	108
KSA1000DLL42A	114	KSA250ABCB4	85	KSA250DZCH43F	129	KSA400DLR42F	109
KSA1000DLL42F	115	KSA250ABDD4	80, 175	KSA250DZE41A	130	KSA400DLR43A	110, 116
KSA1000DLR41A	106	KSA250ABDD5	81, 176	KSA250DZE41F	131	KSA400DLR43F	111, 117
KSA1000DLR41F	107	KSA250ABGD4	82	KSA250DZE43A	132	KSA400DMBK41A	142
KSA1000DLR42A	108	KSA250ABGD5	83	KSA250DZE43F	133	KSA400DMBK41F	143
KSA1000DLR42F	109	KSA250ABT4	36	KSA250ED33012	89	KSA400DMBK43A	144
KSA1000DLR43A	110, 116	KSA250ABTZFL21	87	KSA250ED35020	89	KSA400DMBK43F	145
KSA1000DLR43F	111, 117	KSA250ABZFL21	86	KSA250ED4081	178	KSA400DMBL41A	134
KSA1000DMBK41A	142	KSA250AE4	84, 177	KSA250ED4156	88	KSA400DMBL41F	135
KSA1000DMBK41F	143	KSA250CM4A	181	KSA250ED4208	88	KSA400DMBL43A	136
KSA1000DMBK43A	144	KSA250CM4AF	181	KSA250ED43012	40	KSA400DMBL43F	137
KSA1000DMBK43F	145	KSA250DLC401	42	KSA250ED4306	38	KSA400DMCK41A	146
KSA1000DMBL41A	134	KSA250DLC43B	118	KSA250ED45010	39	KSA400DMCK41F	147
KSA1000DMBL41F	135	KSA250DLC4AM	191	KSA250ED45020	41	KSA400DMCK43A	148
KSA1000DMBL43A	136	KSA250DLC4CFM	191	KSA250ET430	90	KSA400DMCK43F	149
KSA1000DMBL43F	137	KSA250DLE401	43	KSA250ET43A	92	KSA400DMCL41A	138
KSA1000DMCK41A	146	KSA250DLE41A	94	KSA250ET43AF	92	KSA400DMCL41F	139
KSA1000DMCK41F	147	KSA250DLE41F	95	KSA250ET450	91	KSA400DMCL43A	140
KSA1000DMCK43A	148	KSA250DLE42A	96	KSA250ET4AFM	190	KSA400DMCL43F	141
KSA1000DMCK43F	149	KSA250DLE42F	97	KSA250ET4AM	190	KSA400DTC40	150
KSA1000DMCL41A	138	KSA250DLE43A	98	KSA250EV4203	179	KSA400DXC40	151
KSA1000DMCL41F	139	KSA250DLE43B	119	KSA250EV4254	180	KSA400DZCG41A	122
KSA1000DMCL43A	140	KSA250DLE43F	99	KSA250FA4	164	KSA400DZCG41F	123
KSA1000DMCL43F	141	KSA250DLE4AM	192	KSA250ZJ4	65	KSA400DZCG43A	124
		KSA250DLE4CFM	193	KSA250HD502	158	KSA400DZCG43F	125
		KSA250DLF401	44	KSA400AB4	34-35, 174	KSA400DZCH41A	126
		KSA250DLF41A	100				

Index catalogue numbers

Cat. no.	Pages
KSA400DZCH41F	127
KSA400DZCH43A	128
KSA400DZCH43F	129
KSA400DZE41A	130
KSA400DZE41F	131
KSA400DZE43A	132
KSA400DZE43F	133
KSA400ED33012	89
KSA400ED35020	89
KSA400ED4081	178
KSA400ED4156	88
KSA400ED4208	88
KSA400ED43012	40
KSA400ED4306	38
KSA400ED45010	39
KSA400ED45020	41
KSA400ET430	90
KSA400ET43A	92
KSA400ET43AF	92
KSA400ET450	91
KSA400ET4AFM	190
KSA400ET4AM	190
KSA400EV4203	179
KSA400EV4254	180
KSA400FA4	164
KSA400ZJ4	65
KSA40HD502	158
KSA500ED3306	89
KSA500ED35010	89
KSA500ED43010	40
KSA500ED4306	38
KSA500ED45010	39
KSA500ED45018	41
KSA500ET430	90
KSA500ET450	91
KSA500EV4153	178
KSA500EV4203	179
KSA500EV4254	180
KSA500FA4	164
KSA500FR425	164
KSA630ABD4	34, 174
KSA630ABDD4	80, 175
KSA630ABDD5	81, 176
KSA630ABG4	35
KSA630ABGD4	82
KSA630ABGD5	83
KSA630ABT4	36
KSA630ABTZFL21	87
KSA630ABZFL21	86
KSA630AE4	84, 177
KSA630CM4A	181
KSA630CM4AF	181
KSA630DLC401	42
KSA630DLC43B	118
KSA630DLC4AM	191
KSA630DLC4CFM	191
KSA630DLE401	43
KSA630DLE41A	94
KSA630DLE41F	95
KSA630DLE42A	96
KSA630DLE42F	97
KSA630DLE43A	98
KSA630DLE43B	119
KSA630DLE43F	99
KSA630DLE4AM	192
KSA630DLE4CFM	193
KSA630DLF401	44
KSA630DLF41A	100
KSA630DLF41F	101

Cat. no.	Pages
KSA630DLF42A	102
KSA630DLF42F	103
KSA630DLF43A	104
KSA630DLF43B	120
KSA630DLF43F	105
KSA630DLF4AM	194
KSA630DLF4CFM	195
KSA630DLL41A	112
KSA630DLL41F	113
KSA630DLL42A	114
KSA630DLL42F	115
KSA630DLR41A	106
KSA630DLR41F	107
KSA630DLR42A	108
KSA630DLR42F	109
KSA630DLR43A	110, 116
KSA630DLR43F	111, 117
KSA630DMBK41A	142
KSA630DMBK41F	143
KSA630DMBK43A	144
KSA630DMBK43F	145
KSA630DMBL41A	134
KSA630DMBL41F	135
KSA630DMBL43A	136
KSA630DMBL43F	137
KSA630DMCK41A	146
KSA630DMCK41F	147
KSA630DMCK43A	148
KSA630DMCK43F	149
KSA630DMCL41A	138
KSA630DMCL41F	139
KSA630DMCL43A	140
KSA630DMCL43F	141
KSA630DTC40	150
KSA630DXC40	151
KSA630DZCG41A	122
KSA630DZCG41F	123
KSA630DZCG43A	124
KSA630DZCG43F	125
KSA630DZCH41A	126
KSA630DZCH41F	127
KSA630DZCH43A	128
KSA630DZCH43F	129
KSA630DZE41A	130
KSA630DZE41F	131
KSA630DZE43A	132
KSA630DZE43F	133
KSA630ED3306	89
KSA630ED35010	89
KSA630ED4081	178
KSA630ED4154	88
KSA630ED4206	88
KSA630ED43010	40
KSA630ED4306	38
KSA630ED4307	40
KSA630ED45010	39
KSA630ED45011	41
KSA630ED45018	41
KSA630ET430	90
KSA630ET43A	92
KSA630ET43AF	92
KSA630ET450	91
KSA630ET4AFM	190
KSA630ET4AM	190
KSA630EV4153	178
KSA630EV4203	179
KSA630EV4254	180
KSA630ZJ4	65
KSA800ED3306	89

Cat. no.	Pages
KSA800ED35010	89
KSA800ED43010	40
KSA800ED4306	38
KSA800ED45010	39
KSA800ED45018	41
KSA800ET430	90
KSA800ET450	91
KSA800EV4153	178
KSA800EV4203	179
KSA800EV4254	180
KSA800FA4	164
KSA800E25	46

KSB

KSB1000ZB1	64
KSB1000ZB2	64
KSB1000ZF1	46
KSB1000ZFKP1	47
KSB1000ZP1	64
KSB1000ZP2	64
KSB1000ZV1	182
KSB1000ZV2	182
KSB1000ZV3	182
KSB100SE4	58
KSB100SE5	59
KSB100SF4	54
KSB100SF5	54
KSB100SM412	52
KSB100SM512	52
KSB100SV4	152
KSB100SV5	153
KSB125HD5	158
KSB125HD502	159
KSB160DB412	160
KSB160DB512	161
KSB160DC4	62
KSB160DC5	63
KSB160DD411	157
KSB160DM4	61
KSB160DM5	61
KSB160SE4	58
KSB160SE5	59
KSB160SF4	58
KSB160SF5	59
KSB160SFZFL21	163
KSB160SG4	53
KSB160SM413	60
KSB160SM424	183
KSB160SM513	60
KSB160SM524	183
KSB160SV4	152
KSB160SV5	153
KSB16CN5	48
KSB20CG5	48
KSB250DB412	160
KSB250DB512	161
KSB250DC4	62
KSB250DC4SP	185
KSB250DC4TRE	156
KSB250DC5	63
KSB250DC5TRE	156
KSB250DCZFL21	163
KSB250HD502	159
KSB250SDF4	155
KSB250SDF5	155
KSB250SE4	58
KSB250SE5	59
KSB250SM428	184
KSB250ZV1	182

Cat. no.	Pages
KSB25SD4	56
KSB25SD5	57
KSB25YA4	165
KSB32CF5	48
KSB32CM55	49
KSB32CP	49
KSB32CP11D	51
KSB32CP11F	50
KSB32CP15D	51
KSB32CP15F	50
KSB32CP35	51
KSB32SG4	53
KSB400DB412	160
KSB400DB512	161
KSB400DC4	62
KSB400DC4TRE	156
KSB400DC5	63
KSB400DC5TRE	156
KSB400DCZFL21	163
KSB400DD411	157
KSB400HD502	159
KSB400SDF4	155
KSB400SDF5	155
KSB400SE4	58
KSB400SE5	59
KSB400ZB1	64
KSB400ZB2	64
KSB400ZF1	46
KSB400ZFKP1	47
KSB400ZV1	182
KSB50SF4	54
KSB50SF5	54
KSB50SN4	56
KSB50SN5	57
KSB50SV4	152
KSB50SV5	153
KSB630SE4	154
KSB630SE5	154
KSB630ZV1	182
KSB63EGP	163
KSB63PMP	163
KSB63SD4	56
KSB63SD5	57
KSB63SM48	52
KSB63SM58	52
KSB80SG4	53
KSBQPRD	162

KSE

KSE50YA2	165
KSE80YB2	165

Presentation

A Canalis installation for every distribution system

Schneider Electric offers different distribution systems to fit all your operating needs.

The Canalis decentralized distribution concept.

Upgradeable during operation

In decentralized distribution, evolving operating requirements and costs are integrated right from the start.

- The addition, relocation or replacement of load equipment can be carried out quickly, without de-energizing the supply trunking or shutting down operation.
- The cost of making such changes is greatly reduced:
 - loads are located close to supply points
 - tap-off points are always available
 - tap-units can be reused or new ones added quickly for load.

Relocation or replacement needs.

- Reusable in the event of major changes.
- When making major modifications to your installation, the existing trunking can be easily dismantled and reused.

B

DB410747.eps

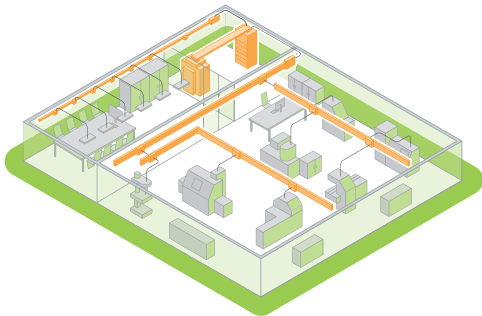

Decentralized distribution

For manufacturing industries

- Mechanical
- Textiles
- Lumber
- Injection moulding
- Electronics
- Pharmaceuticals
- Livestock, etc.

Decentralized distribution lets you

- Design installations without layout details
- Upgrade without shutting down production
- Get systems up and running sooner thanks to faster installation
- Generate savings depending on the number of loads.

DD406593.eps

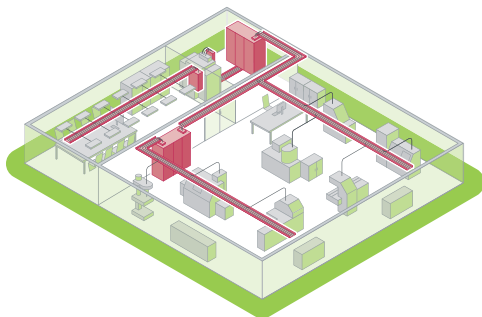

Centralized distribution

For all continuous processes

- Cement plants
- Oil and gas
- Petrochemicals
- Steel
- Paper, etc.

Centralized distribution offers

- Continuity of service
- Combined distribution of power, control and monitoring circuits
- Supervision, etc.

DB410746.eps

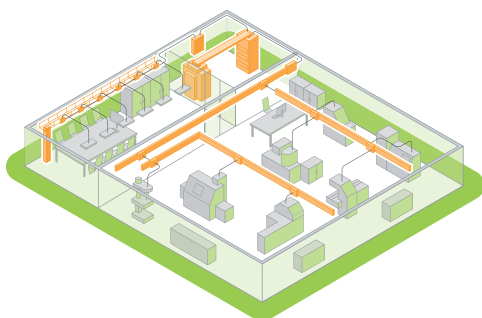

Combined distribution

Where the advantages of both centralized and decentralized distribution are required.

Commercial and service buildings

- Offices
- Stores
- Hospitals
- Exhibition halls, etc.

Infrastructures

- Airports
- Telecommunications
- Internet data centres
- Tunnels, etc.

Industrial facilities

- Pharmaceuticals
- Food processing, etc.

Presentation

The Canalis decentralized distribution concept

Electrical power available at all points within the installation

Total coordination of the Schneider Electric system provides maximum protection for life and property, continuity of service, upgradeability and ease of installation.



Exclusive features of the Schneider Electric system

Total coordination is made easy by the tables in the "Design Guide". They help you choose the right combination of circuit breakers and busbar trunking. Product characteristics are verified by calculations and tests carried out in our laboratories.

A competitive installation

Simplicity, upgradeability, enhanced performance and continuity of service and operation.

Savings start as soon as the installation begins. With tap-off points every 3 metres, Canalis busbar trunking reduces installation costs.

Given the low cost of adding new circuits, savings increase as the number of loads increase, a natural result of the growth of your business.

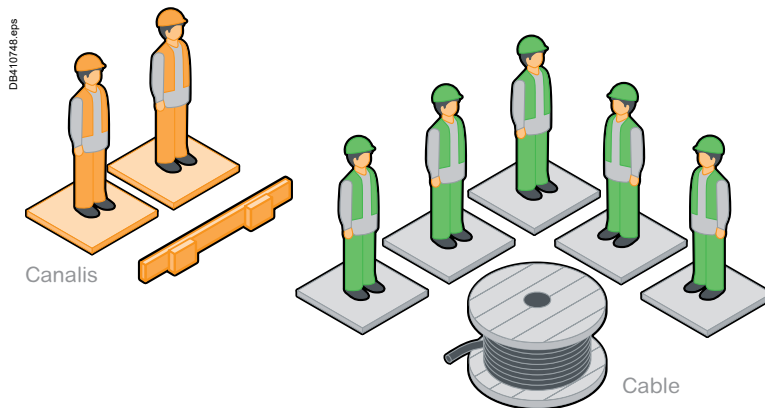

Comparative investment

of 400 A electric power system equipment.

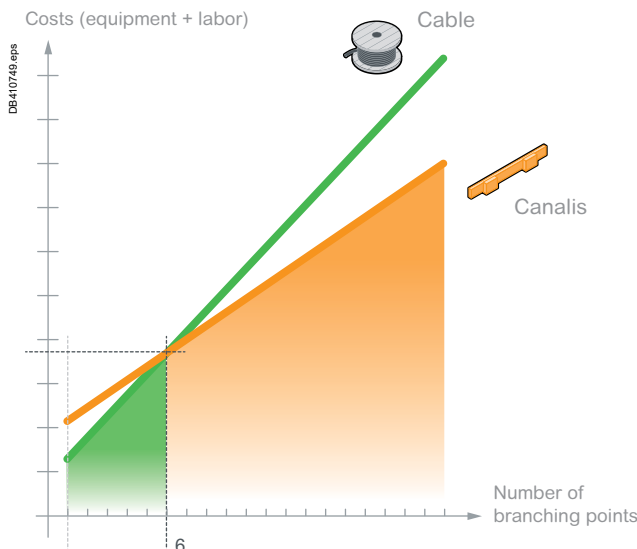

Power distribution is a major challenge in the construction and refurbishment of commercial, industrial buildings and data centers.

The choice of device is fundamental as it will have an effect on the building's lifecycle. Infrastructures should comply with existing requirements while being flexible, networked and smart. The Canalis concept is undoubtedly the right solution to meet the needs of today and the challenges of tomorrow.

Simple to estimate

Designing Canalis installations is straightforward as there is no need to know the exact location, nor the power rating of the loads to be supplied.

It is therefore very quick to cost the distribution functions. Moreover, Canalis's flexibility means you can invest in existing needs without adversely affecting future expansion.

Practical to recycle

Over the last 20 years, recycling has become a major challenge for industry.

The composition of Canalis ranges **offers a 95% recycling rate.**

But the Canalis offers go one better... if a site is being restructured or enlarged, **the products can simply be removed and reinstalled in their new environment.**

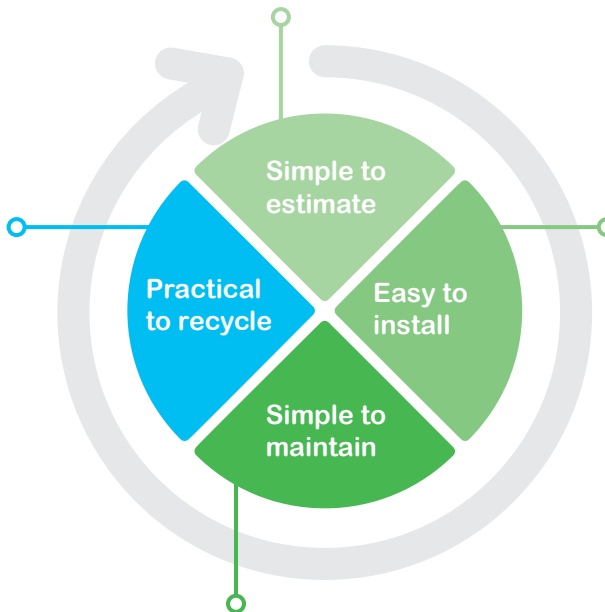

Easy to install

The compact nature of Canalis makes it easy to integrate in all parts of the building.

Since it is based on a decentralized architecture, Canalis can be installed at the same time as the building is being built, which optimizes site construction schedules.

Because of the delayed differentiation linked to the Canalis architecture, new constraints can be taken into account without adding to the installation time.

Controlling costs

The Canalis ranges are factory-tested, which provides a very high level of quality on site and considerably improves the success of site acceptance tests.

Simple to maintain

- **No maintenance is required on the Canalis electrical contacts.**

- The clarity of the Canalis architecture simplifies building maintenance and upgrades:
 - > enlarging office space,
 - > adding check-outs in a supermarket...

Decentralized distribution ensures continuity of service; when associated with a 100% maintained or non-maintained supply, the required functions are met:

- > maintaining the cold chain in a hypermarket,
- > lighting system in a car park...

Canalis®

From 100 to 1000 A

"Electrical energy available throughout your installation."

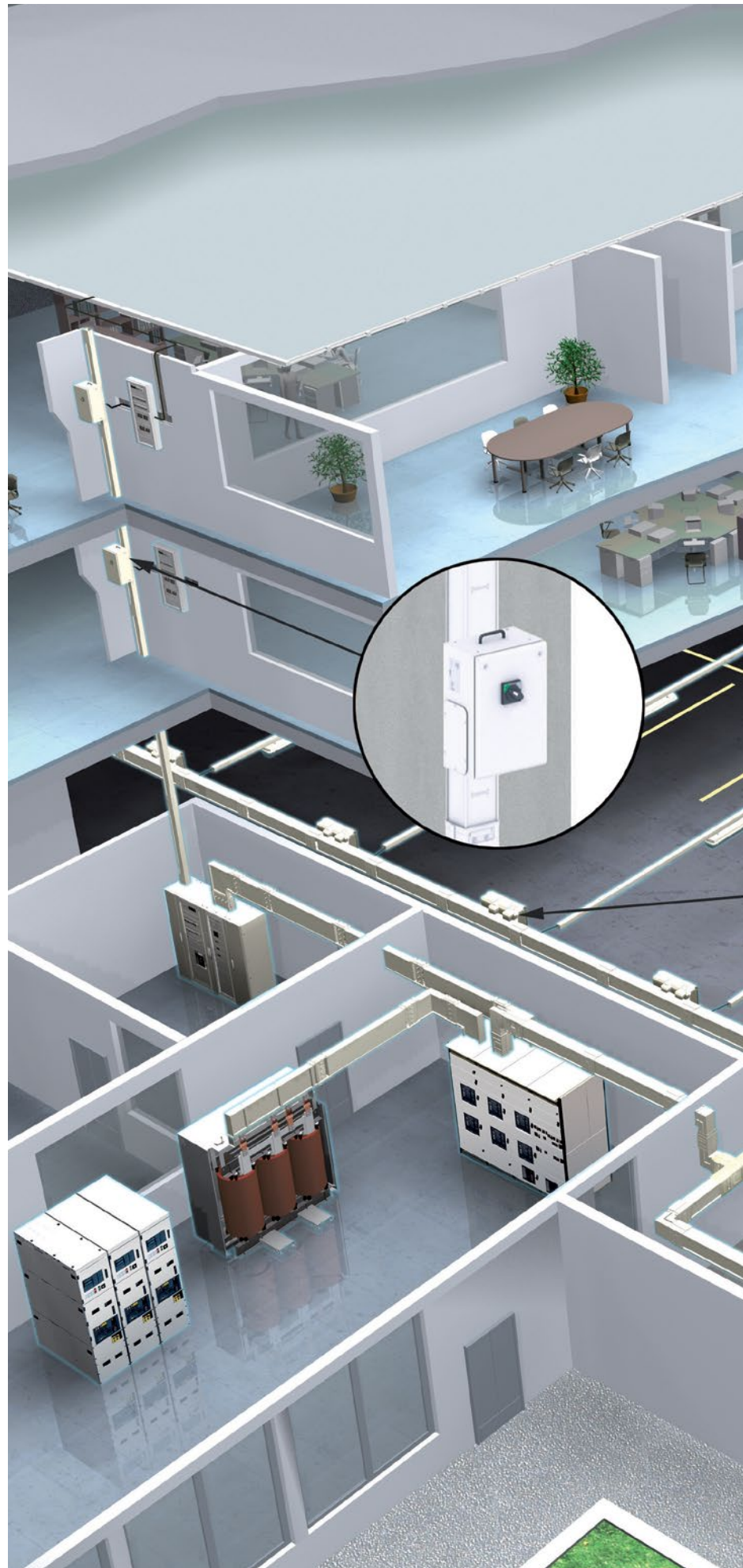

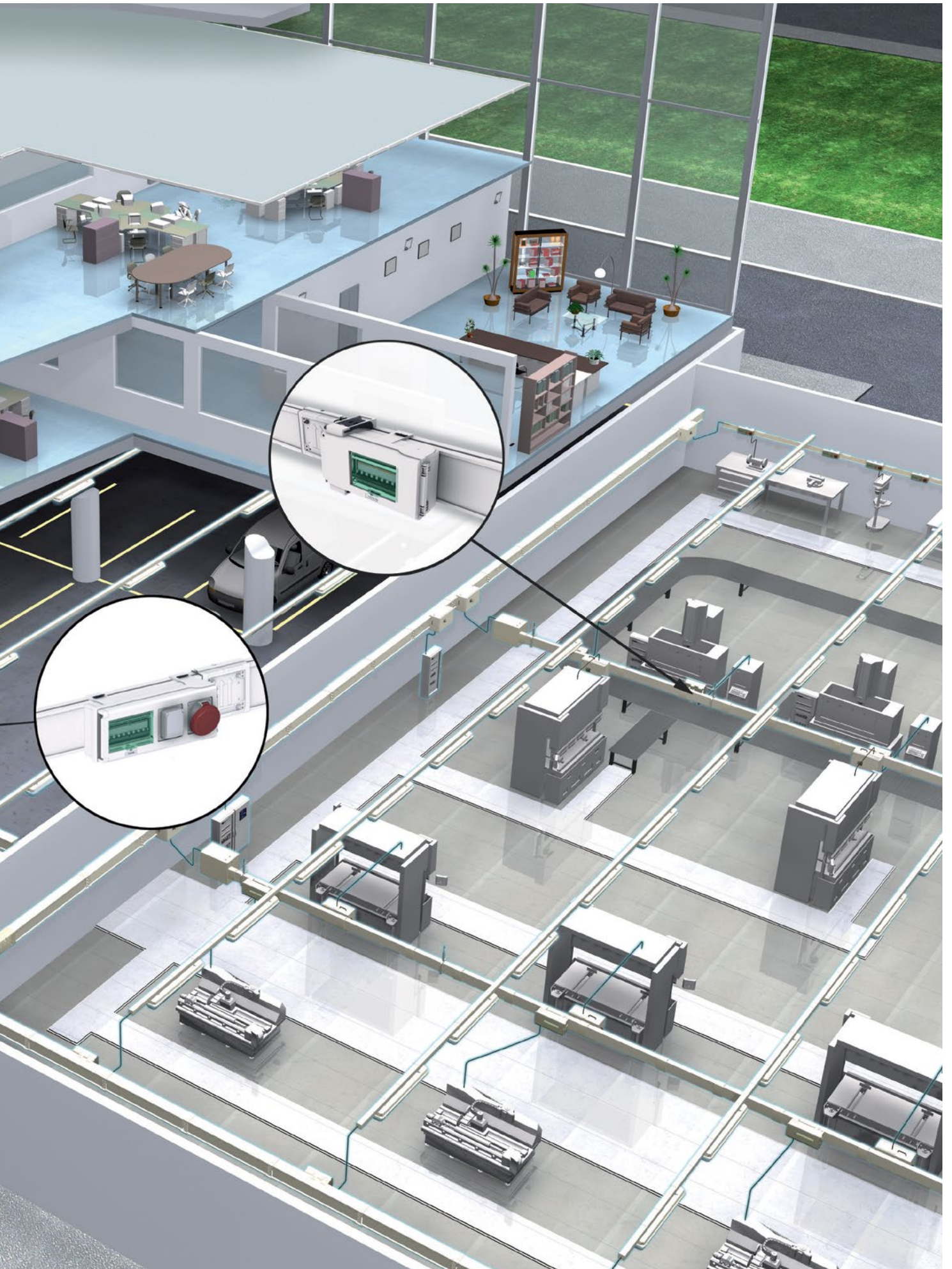

B

Presentation

Canalis tools and services

Working together on your solution

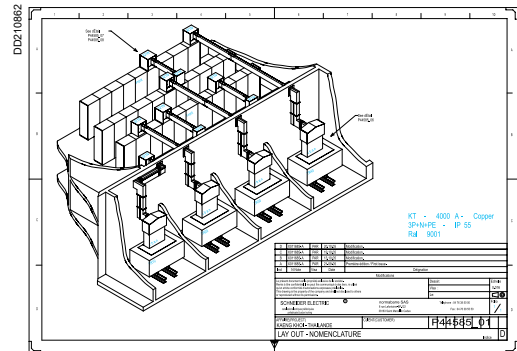

Our teams are available to provide customers with technical assistance throughout the installation of their projects.

Design of electrical distribution architectures:

- design of decentralized transport and distribution systems
- technical and financial optimization of busbar trunking design projects
- transformer/switchboard link
- installation coordination and discrimination.

Full installation drawings*:

- 3D AutoCAD drawings with corresponding parts lists
- 2D drawing with dimensions
- detailed connection drawings

*All AutoCADs are available on Traceparts.com

BIM Models: will be available on Schneider-electric.com in 2019.

Site supervision and commissioning assistance.

Training for designers and contractors.

Canalis Busway "Total Solution":

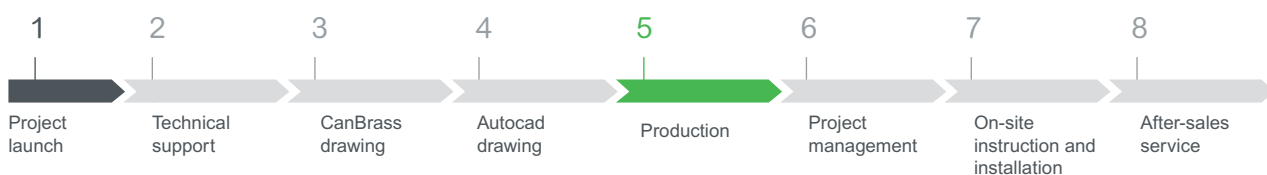

Panorama

Panorama of Canalis range

Low & medium Power Solutions

PD202217_L2



PD202219_L



Busbar trunking for lighting and low power distribution from 25 to 40 A
IP55

Rated service current	Permissible rated peak current	Rated insulation voltage	Color
Inc	Ipk	Ui	
KBA			
25 A	4.4 kA	690 V	Pre-lacquered white (RAL9003)
40 A	9.6 kA		
KBB			
25 A	4.4 kA	690 V	Pre-lacquered white (RAL9003)
40 A	9.6 kA		

PD202221_KN



Power distribution from 40 to 160 A
IP55

Rated service current	Permissible rated peak current	Rated insulation voltage	Color
Inc	Ipk	Ui	
KN			
40 A	6 kA	500 V	Pre-lacquered white (RAL9001)
63 A	11 kA		
100 A	14 kA		
160 A	20 kA		

PB115680-30

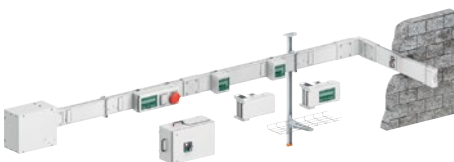

Horizontal and vertical distribution from 100 to 1000 A
IP55

Rated service current	Permissible rated peak current	Rated insulation voltage	Color	
Inc	Ipk	Ui		
KS				
Aluminium:	Copper:	690 V	Pre-lacquered white (RAL9001)	
100 A				15.7 kA
160 A	160 A			22 kA
250 A	250 A			28 kA
400 A	400 A			49.2 kA
500 A				55 kA
630 A	630 A			67.5 kA
800 A	800 A			78.7 kA
1000 A		78.7 kA		

Panorama

Panorama of Canalis range

C

Line components		Branching points			Accessories
Length of components	Number of conductors	Center to center distance		Protection type	
2 m and 3 m	2 or 4 + PE	0.5 m, 1 m on 1 side	L + N + PE or 3L + N + PE (10/16 A) pre-cabled or to be cabled, with phase selection or fixed polarity, with lighting control	With fuses or without protection	<ul style="list-style-type: none"> > Flexible components > Fixing devices with quick adjustment > Communication bus (DALI, ASI) > Cable ducts
2 m and 3 m	Single circuit 2 or 4 + PE Dual circuit 2 + 2 + PE 2 + 4 + PE 4 + 4 + PE	0.5 m or 1 m on 1 or 2 sides	L + N + PE or 3L + N + PE (10/16 A) pre-cabled or to be cabled, with phase selection or fixed polarity, with lighting control	With fuses or without protection	<ul style="list-style-type: none"> > Flexible components > Fixing devices with quick adjustment > Communication bus (DALI, ASI) > Cable ducts

Line components		Branching points			Accessories
Length of components	Number of conductors	Center to center distance		Protection type	
2 m and 3 m	4 + PE	0.5 m, 1 m on 1 side	16 A to 63 A (plug-in)	Units for modular circuit breakers, fuses and sockets	<ul style="list-style-type: none"> > Flexible components > Fixing devices with quick adjustment > Remote control bus > Cable ducts > Installation accessories

Line components		Branching points			Accessories
Length of components	Number of conductors	Center to center distance		Protection type	
3 m, 5 m and additional or customized components	4 + PE	0.5 m or 1 m on each side for horizontal version, and on one side for vertical version	16 A to 400 A (plug-in)	Units for circuit breakers (modular, Compact NSX), fuses, sockets	<ul style="list-style-type: none"> > Riser ducting offer > Fixing devices with quick adjustment > Cable ducts > Installation accessories > Fire barriers

Panorama

Panorama of Canalis range

High Power Solutions



Power transmission and distribution
from 800 to 6300 A
IP55

Rated service current		Permissible rated peak current		Rated insulation voltage	Color
Inc		l _{pk}		Ui	
KT *					
Aluminium:	Copper:	Standard:	Optional:	1000 V	Pre-lacquered white (RAL9001)
800 A	-	64 kA	73 kA		
1000 A	1000 A	110 kA	143 kA		
1250 A	1350 A	110 kA	143 kA		
1600 A	1600 A	143 kA	187 kA		
2000 A	2000 A	154 kA	242 kA		
2500 A	2500 A	176 kA	248 kA		
3200 A	3200 A	189 kA	248 kA		
4000 A	4000 A	198 kA	264 kA		
5000 A	5000 A	209 kA	264 kA		
-	6300 A	209 kA	264 kA		

* Canalis KT range is available on schneider-electric.com or catalogue:
KTA: ref. DEBU021EN / KTC: ref. DEBU024EN

Power transmission for outdoor and
harsh environment from 800 to 6300 A
IP68

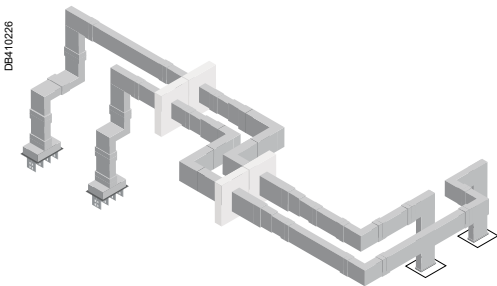

Rated service current	Permissible rated peak current		Rated insulation voltage	Color
Inc	Aluminium:	Copper:	Ui	
KR *				
800 A	56 kA	-	1000 V	Gray (RAL7030)
1000 A	56 kA	80 kA		
1250 A	117 kA	-		
1350 A	-	80 kA		
1600 A	117 kA	143 kA		
2000 A	143 kA	176 kA		
2500 A	176 kA	176 kA		
3200 A	220 kA	220 kA		
4000 A	220 kA	220 kA		
5000 A	220 kA	275 kA		
6300 A	-	275 kA		

* Canalis KR range is available on Schneider-electric.com or catalogue ref. DEBU031EN

Panorama

Panorama of Canalis range

Line components		Branching points			Accessories
Length of components	Number of conductors	Center to center distance		Protection type	
2 m and 4 m	3P + PE 3P + N + PE 3P + N + PER	0.5 m or 1 m	25 A to 630 A (plug-in) 400 A to 1250 A (bolt-on)	Units for circuit breakers (modular, Compact NSX), fuses, sockets	<ul style="list-style-type: none"> > Power supply ends > Direction change angles and T-pieces > Fixing devices and fuses

C

Line components		Branching points			Accessories
Length of components	Number of conductors	Center to center distance		Protection type	
Up to 3 m	3L 3L + N or 3L + PE or 3L + PEN 3L + N + PE	-	-	-	<ul style="list-style-type: none"> > Power supply ends > Direction change angles and T-pieces > Fixing devices > Fire resistant elements

Presentation

Canalis is adapted for all types of buildings

Key points

Parkings

- Installation protection
- Operating continuity
- Energy management

Garages

- Installation protection
- Evolutivity
- Costs reduction
- Operating continuity

Cruise ships

- Installation protection
- Flexibility
- Competitivity

Logistic centers

- Installation protection
- Evolutivity
- Costs reduction

Warehouses

- Installation protection
- Easy to maintain
- Costs reduction
- Evolutivity

Livestock production buildings

- Installation protection
- Easy to maintain
- Evolutivity

Hypermarkets

- Operating continuity
- Installation protection
- Evolutivity

Offices

- Comfort
- Installation protection
- Energy savings

Data centers

- Operating continuity
- Installation protection
- Evolutivity

Industrial Buidings

- Installation protection
- Evolutivity
- Costs reduction
- Operating continuity





Solution for Data Center

- iBusway for Data Center catalogue: **DEBU028EN**
- iBusway for Data Center brochure: **DEBU027EN**

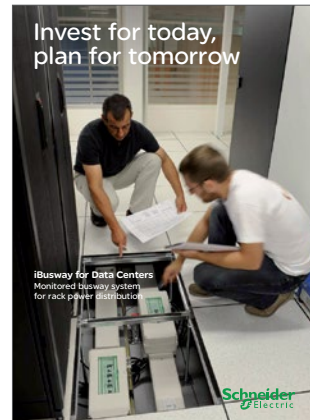
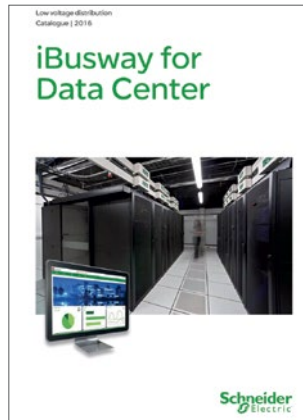

Solution for lighting management

- iBusway for lighting management: Canalis DALI technical installation guide **DEBU032EN**
- Brochure iBusway for lighting management: **DESWED112002EN**
- Catalogue iBusway for lighting management: **DEBU035EN**

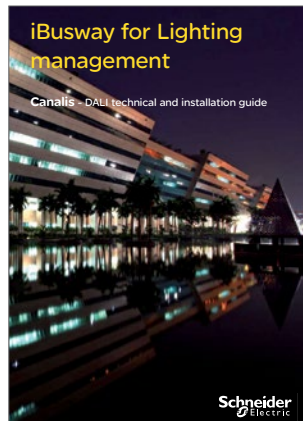

Application datasheets/Guide

- In cruise ships: **DESWED105014EN**
- In livestock production buildings: **DESWED105010EN**
- In logistic centers: **DESWED105011EN**
- In car parks: **DESWED108011EN**
- In greenhouses: **DESWED105013EN**
- In garages: **DESWED106004EN**
- In hypermarkets: **KD0C98CTAHYEN**
- In automotive industry: **KD0C98CTAAUEN**



Presentation

Canalis KS means business!

As an electrical engineering specialist in the service and industrial buildings sector, you want to offer your customers optimal continuity of service while controlling costs and meeting deadlines.

Schneider Electric know-how at your disposal

With Canalis KS, you obtain all the modularity, engineering design and innovation developed by the world leader in electricity distribution. This range of busbar trunking comprises:

- a large choice of ratings
- customized elements adapted to your installation constraints
- protection devices to provide continuity of service and the protection of personnel and equipment.

Protection of personnel and electrical equipment

With Canalis KS, you have a dependable electrical system, because the prefabricated busbar trunking has been optimized and tested in accordance with the IEC 61439-6 standard.

The entire Canalis KS range is contains neither halogen nor PVC

This means no toxic emission in case of fire. Thanks to fire-break elements, the fire is confined for two hours, in vertical and horizontal positions.



A high degree of protection

A high degree of protection for Canalis KS means it can be installed in all types of buildings.

- **IP55** guarantees trunking protection against splashes and dust.
- **IK08** guarantees the strength of the trunking (resistance to shocks).
- **IPxxD** ensures secure working conditions for maintenance personnel.
- Canalis KS complies with **sprinkler tests**, guaranteeing operation under vertically and horizontally sprayed water for 50 minutes.



An environmentally friendly lifecycle

Manufacturing, packing and distribution processes have been designed to limit the environmental impact of our products. In service, KS busbar trunking dissipates less than 0.1% of the total power circulating in the product. At end of life, over 90% of the materials used can be recycled by crushing or dismantling.



Schneider Electric has employed all its expertise to optimize the energy consumption of your electricity distribution system. With Canalis KS, reduce the CO² impact of your system.

Losses

- Canalis KS 250 A: 3.5 kWh/100 m
- 250 A cables: 5.7 kWh/100 m
- difference: 2.2 kWh/100 m, i.e. for one year = 19272 kWh/year/100 m.

Discharge of CO²/100 m

19272 x 0.64 kg/kWh ⁽¹⁾ = 12.3 tonnes year/100 m.

Saving achieved

19272 x € 0.084 ⁽²⁾ = € 1619/year/100 m.

⁽¹⁾ CO² emissions per kWh: 0.64 kg CO²/kWh (source: International Energy Agency).

⁽²⁾ Industrial cost of 1 kWh = € 0.084 (source: Eurostat, January 2006), for an annual consumption of 2000 mWh, excluding VAT.

For more information, the environmental profile of the Canalis KS range is available on:

www.schneider-electric.com

"Canalis KS is a range of prefabricated busbar trunking and tap-off units designed for you and your customers."

Our performance... Your values

PB11550-00.eps

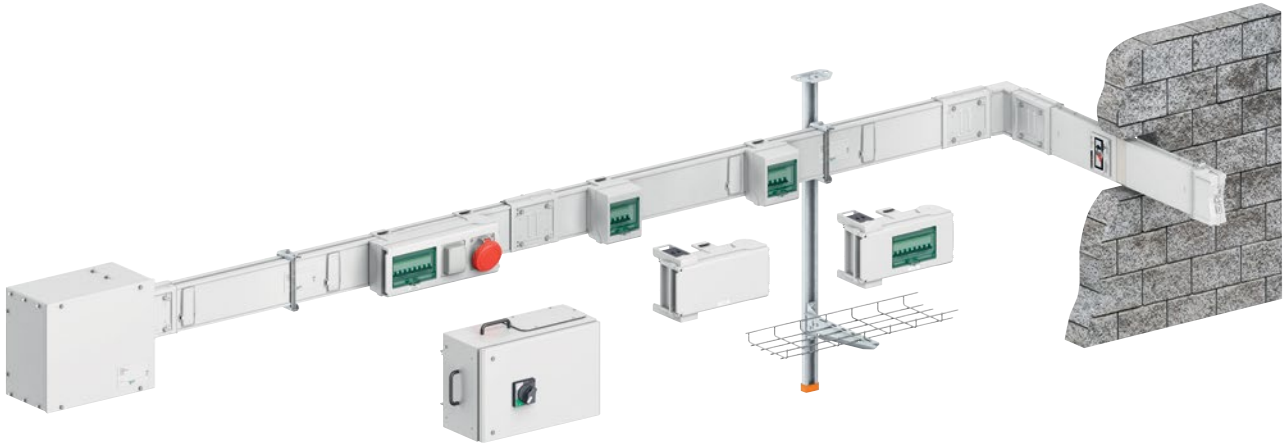

C

Light and easy to handle

Canalis KS trunking equipped with aluminium conductors is 40 % lighter, for equal power ratings.

Excellent contact

Contacts are silver-plated. The level of performance remains the same throughout the life of the product.

Incomparable scalability

The electrical busbar trunking has a high density of tap-off points even in rising mains, due to the absorption of differential expansion by the junctions. The tap-off units can be added or removed busway energized.

Easy handling and installation

Because the available space in technical ducts is limited, Canalis KS uses significantly less room compared to a centralized distribution system using cables. Installation is made easy due to the design of the jointing units that facilitate alignment of the straight lengths.

Maintenance free

All sliding joint contacts are lubricated for the life of the product.

Very flexible

The floor-distribution components in the Canalis KS range offer 3 or 4 tap-off outlets per floor, which means you have reserve outlets for future upgrades.

Feed units with protection device

These provide line protection. They make it possible to perform operations on a line by de-energizing it, without interrupting the power supply of the whole system.

A complete range of tap-off units

- The range covers all needs from 16 to 400 A.
- Protection is possible using circuit breakers, fuses or surge arresters.
- Also available are 32 A tap-off units equipped with household and industrial power sockets.

Create intelligent tap-off units using all Schneider Electric devices

- To monitor the installation to avoid overloads and provide continuity of service.
- To meter the energy consumed for precise management (cost allocation for each consumer).

Presentation

Canalis KS for medium-power distribution from 100 to 1000 A

PE115950_0pps

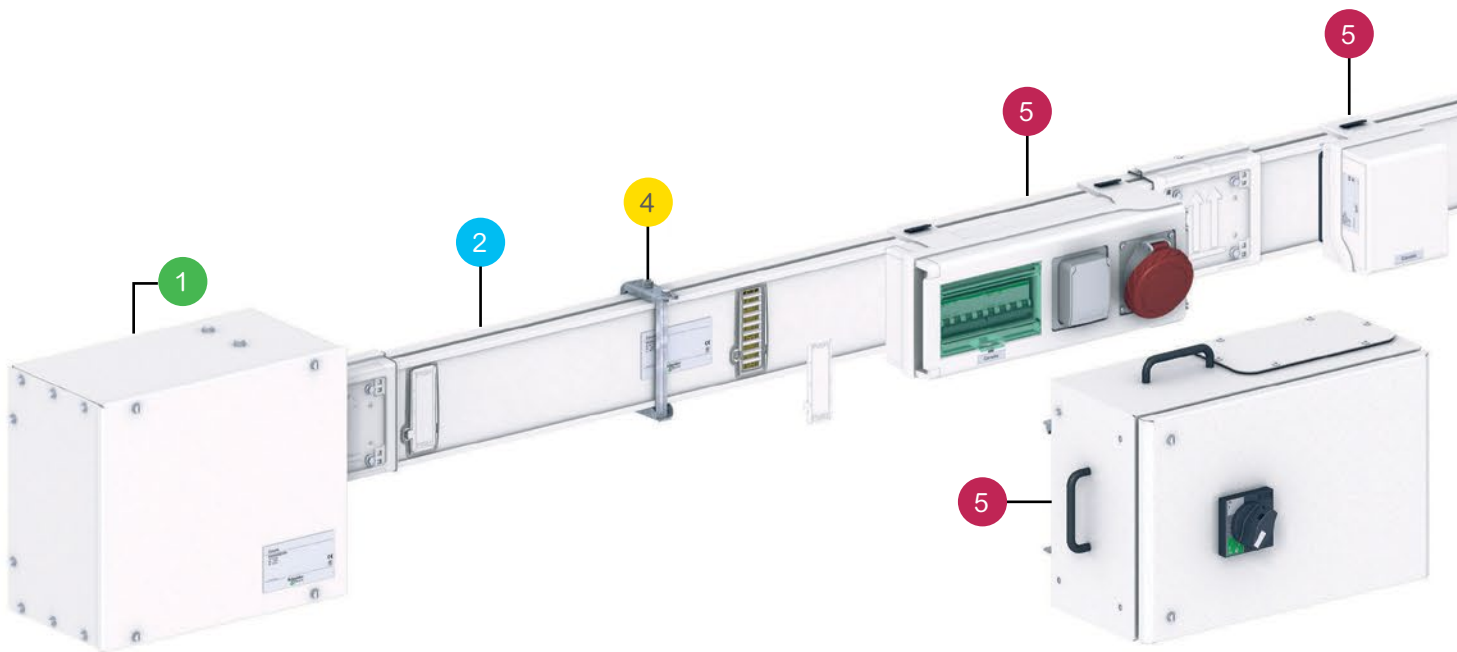

1. Feed units and end covers

The feed units delivered with end covers, receive the cables supplying at one end or any other point of Canalis KS trunking.

2. Straight lengths

- Rating: 100, 160, 250, 400, 500, 630, 800, 1000 A.
- 4 live conductors (3L+N+PE).
- Length:
 - classic offer: 3 and 5 metres
 - advanced offer: 1.5 and 2 metres and 3 live conductors (3L+PE).

PD02205_1W

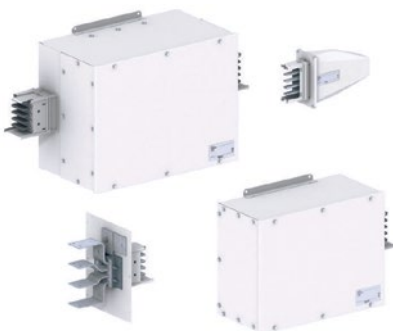

PD02204_1W

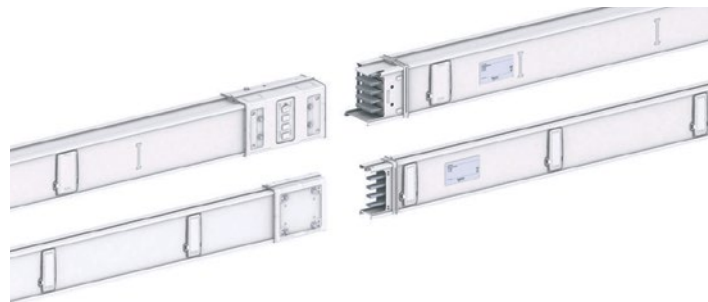

Canalis KS for medium-power distribution from 100 to 1000 A

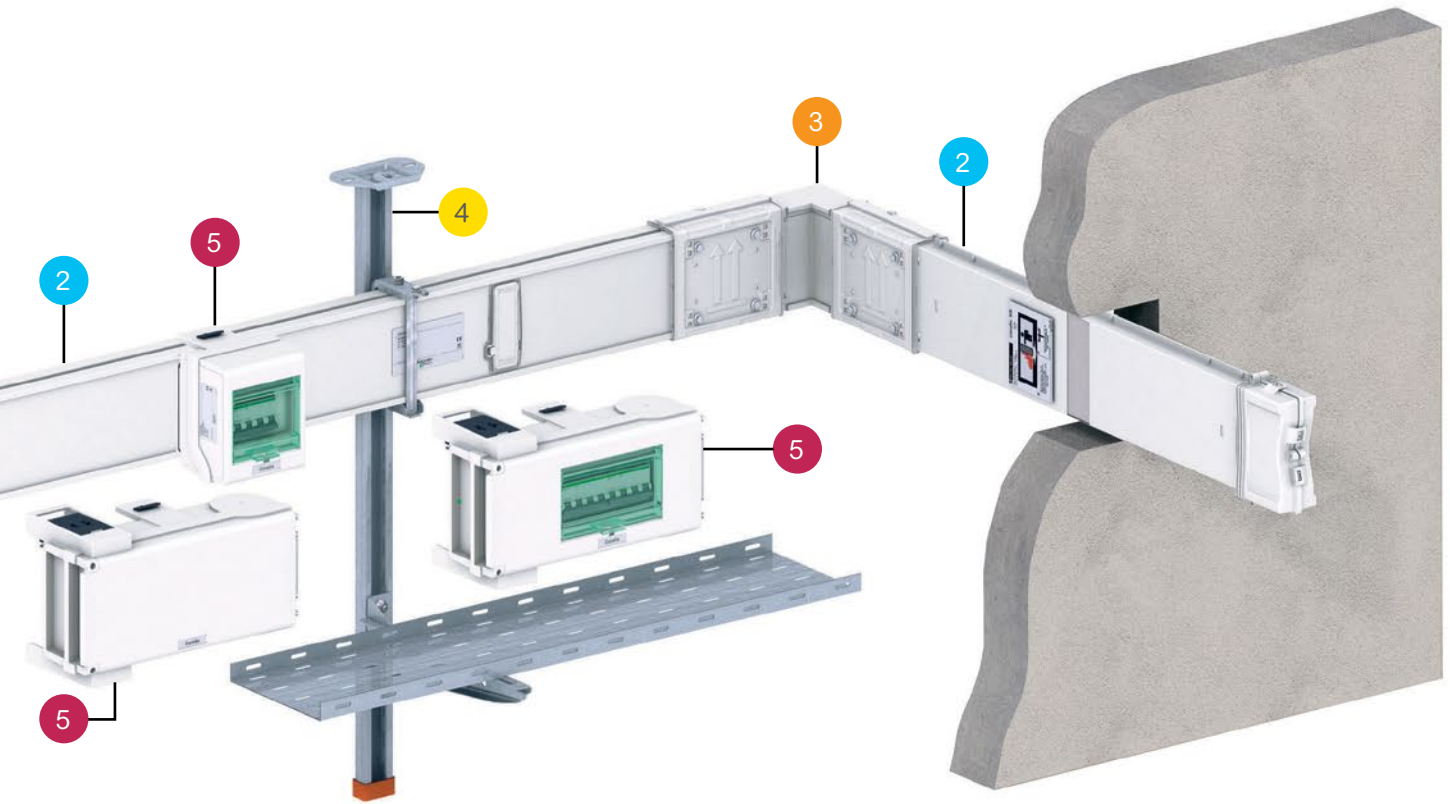

3. Change direction elements

All components for changing direction are supplied with a junction block.

4. Fixing system

The fixing system keeps the Canalis KS well arranged whatever the type of building structure

5. Tap-off units

- The tap-off units (with and without isolators) are used to:
 - supply loads from 25 to 400 A
 - or protect nearby loads against overloads due to lightning strikes.
- Protection is ensured with modular or Compact NSX circuit breakers or fuses.

PB115591



DB403971



PD002207_1W



Canalis KS range Classic offer

Standard and easily available products to create a simple run

Description.....	page 25
Overview	page 33
Commercial numbers and dimensions.....	page 33

Description

Feed units and end covers

From 100 to 1000 A

Used to feed a KS line by cables. They can be mounted at the end of a line (end feed, left or right) or in the middle (central feed).

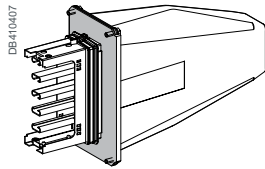

End feed unit for KS 100A trunking Type AB

For KS 100 A trunking only. It can be mounted on either side of a straight length. It is equipped with a PG 29 cable gland (equivalent to M32) and supplied with an end cover.

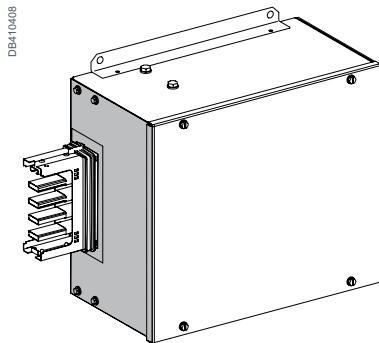

End feed unit for horizontal or vertical trunking Type AB

For 250 to 400 A rating, it can be mounted on either side of a straight length. For 500 to 1000 A rating, two type of end feed units are available:

- left: ABG,
- right: ABD.

Supplied with an end cover.

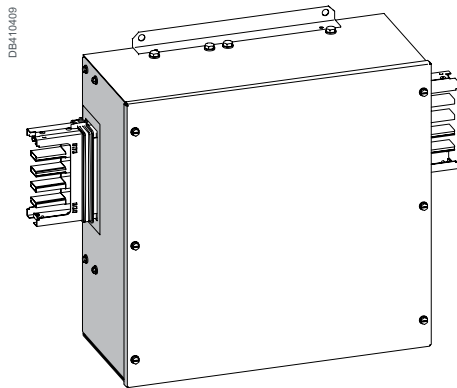

Centre feed unit Type ABT

Using a single cable, it is possible to feed both the right and left-hand sections. It is mounted between two straight lengths in the line and is supplied with two end covers.

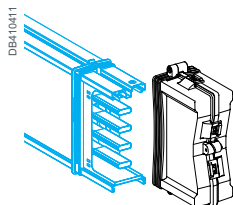

End cover Type AF

The end cover protects and isolates the ends of the conductors. It is mounted on the last component. Supplied with all feed units.

D

Description

Straight lengths with tap-off outlets & changing direction

From 100 to 1000 A

Straight lengths and changing direction components are designed to carry the current and supply loads.

Straight length

Type ED

Components of the Classic offer are available in eight ratings: 100, 160, 250, 400, 500, 630, 800 and 1000 A. Busbar trunking rated 100 to 400 A may be equipped with tap-off units up to 250 A. Higher rating busbar trunking elements may be equipped with the entire range of tap-off units.

All the insulating and plastic materials are halogen-free and have enhanced fire-withstand capabilities (incandescent wire test as per standard IEC 60695-2: 960 °C for components in contact with live parts and 650 °C for other components).

The degree of protection of the busbar trunking is IP55 for indoor installations. For the sprinkler protection, it is necessary to add a specific sealing kit.

The basic structure of the line is made up of:

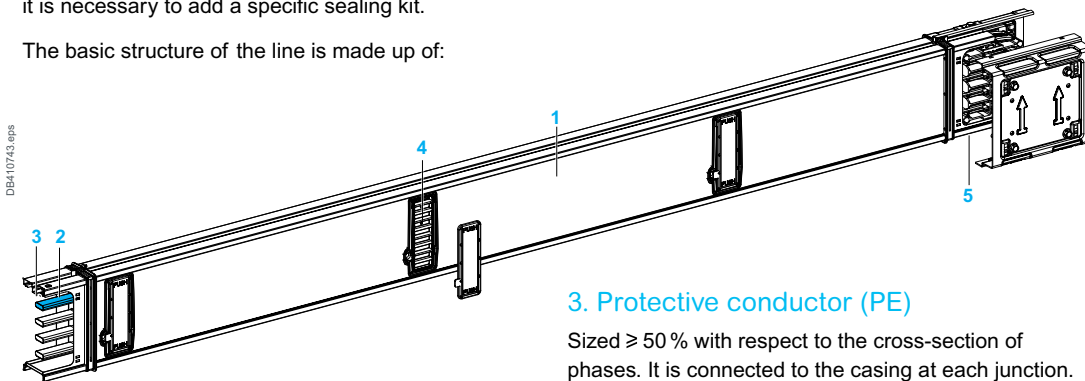

1. Casing, crimp closed, made of hot-galvanised sheet steel

Pre-lacquered RAL 9001 white, this casing, shaped and ribbed by roll-forming, provides excellent resistance to bending and twisting.

2. Conductors

For the 100 and 160 A rating: silver-plated aluminium/copper bimetal laminate.

For the 250 to 1000 A rating: aluminium bars equipped with silver-plated aluminium/copper bimetal laminate contacts electrically welded at junctions and tap-off points.

3. Protective conductor (PE)

Sized $\geq 50\%$ with respect to the cross-section of phases. It is connected to the casing at each junction.

4. Tap-off outlets

From 0.5 to 1 meter on both sides of the trunking.

5. Mechanical and electrical jointing system

Electrical jointing is provided by a block with flexible grip contacts made of silver-plated copper.

This block equally absorbs the difference in conductor and casing thermal expansion for each length.

For the 100 to 250 A rating, the jointing system provides an automatic and simultaneous jointing of all live conductors and the continuity of the protective earth conductor.

For the 400 to 1000 A rating, electrical jointing is ensured by a quarter-turn locking mechanism for each conductor.

Changing direction

Type DL

Used for simple change direction (turn right or left, go upward or downward), all components for changing direction are supplied with a junction block. The degree of protection of the busbar trunking is IP55 for indoor installations.

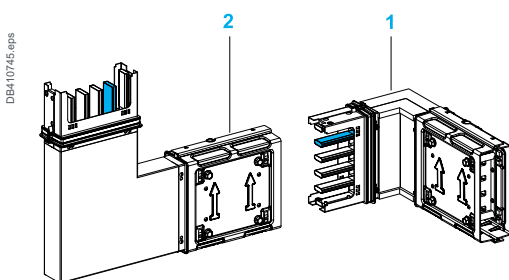

Elbows

Standards

1. Edgewise: one model for turning right or for turning left.
2. Flatwise: two models, one for turning up and the other for turning down.

Description

Fixing systems for horizontal trunking

From 100 to 1000 A

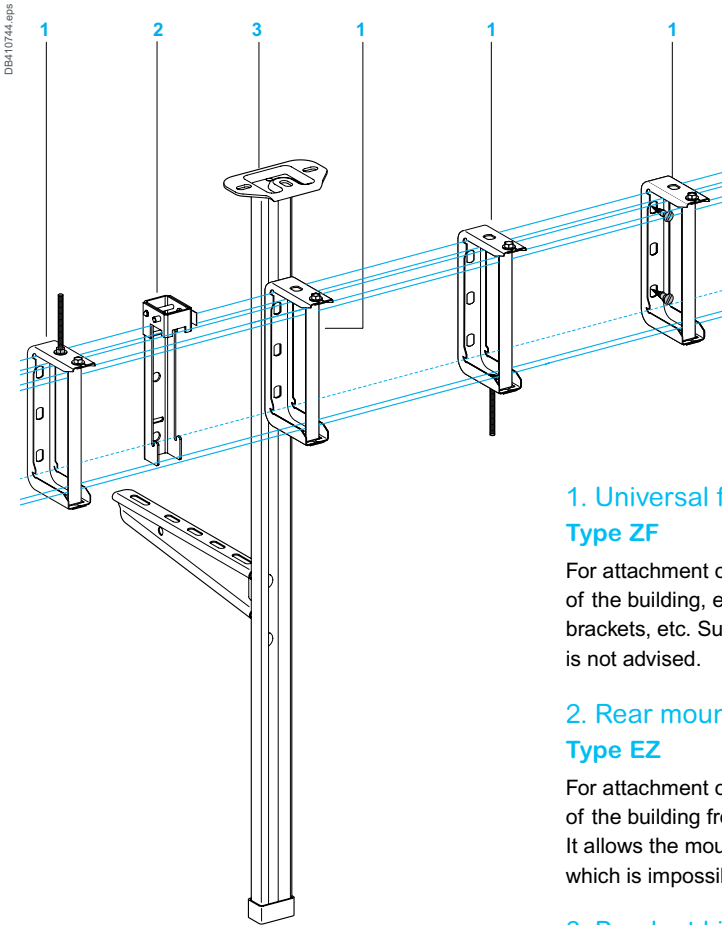

Advice

One fixing bracket every 3 meters is recommended.

1. Universal fixing bracket

Type ZF

For attachment of the busbar trunking to the structure of the building, either directly or via a threaded rod, brackets, etc. Suspension using chains or steel cables is not advised.

2. Rear mounting bracket

Type EZ

For attachment of the busbar trunking to the structure of the building from the rear of the busbar. It allows the mounting of small plastic tap-off units which is impossible with the universal fixing bracket.

3. Pendant kits and cantilever arm

Type ZFKP and KFBKA

The pendant kit includes:

- a perforated pendant used to suspend a KS line from the building structure, an IPN or the ceiling. Length: 1 m, width: 80 mm
- a cantilever arm that supports the cable tray under the KS line
- the mounting hardware required to fix the KS bracket and the cantilever arm to the pendant.

Two kits are available:

- KS Rating up to 400 A: 200 mm cantilever arms
- KS Rating from 500 A to 1000 A: 300 mm cantilever arms. If necessary, additional cantilever arms can be ordered.

Cantilever arms can be ordered separately.

It exists 2 dimensions: 200 mm and 300 mm.

Rating (A)	Dimensions (mm)			
	Height	Width (busbar trunking)	Width (jointing unit)	Length
100 to 400	146	54	63	1500 2000 3000 5000
500 to 1000	146	113	119	1500 2000 3000 5000

Description

Tap-off units

From 100 to 1000 A - General description

For rapid connection of loads or secondary lines, in compliance with installation standards IEC 60364 and regulations, whatever the system earthing arrangement (TT, TNS, TNC or IT). They can be handled and removed under off-load conditions with the trunking energised. Tap-off units can be assembled on either side when the busbar trunking is installed edgewise. It can also be installed on flatwise busbar trunking facing downwards. The tap-off outlets are automatically opened or closed when tap-off units are connected or removed. With the cover open, no live parts are accessible.

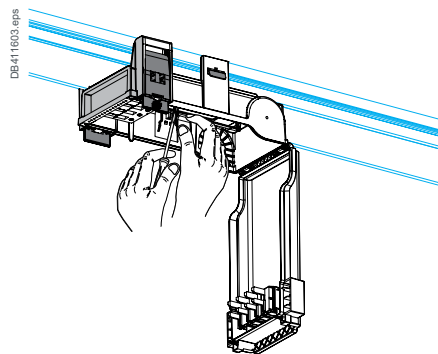
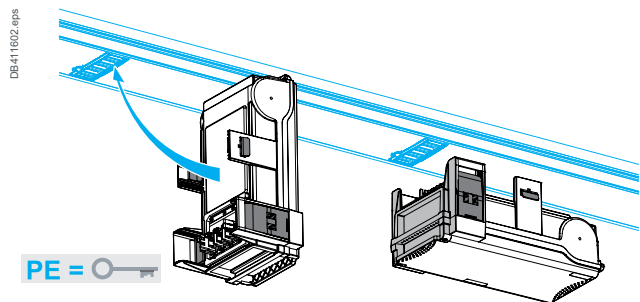
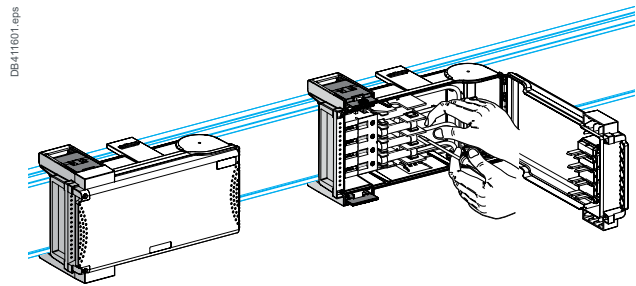
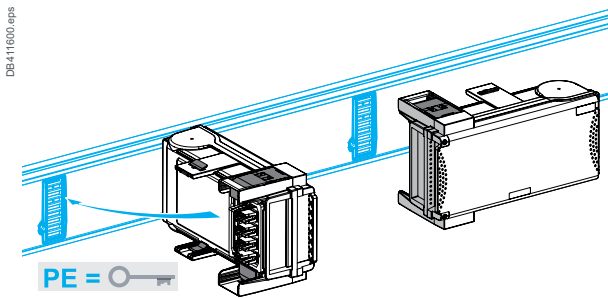

Disconnection principle

Disconnection by unplugging the tap-off unit.

The access to the electrical devices and the terminals is possible only when the tap-off unit is unplugged (i.e. not energised). An interlocking device restricts connection to the trunking when the cover has been removed.

Disconnection of tap-off units with fuses and modular devices (category AC22 to AC20) is obtained by opening the tap-unit cover.

Tap-off unit disconnection by unplugging the tap-off unit or opening the cover should be carried out only if the downstream load is de-energised.

For tap-units with circuit breakers, **restricts:**

- plugging and unplugging in the tap-off unit when the cover is closed
- closing the cover before the tap-off unit is locked onto the trunking
- having access to the electrical equipment and the terminals when energised
- opening the cover in the position "ON" (tap-off units equipped with a Compact NSX or NG circuit breaker).

These tap-off units can be equipped with certain accessories such as circuit-opening contacts on the cover, lead seals, etc.

Description

Tap-off units

From 100 to 1000 A - General description

2 types of housing

1. Connectors (A) and tap-off units with isolators (B) up to 100 A are made of plastic

- Colour: RAL 9001 white for the casing and the grip zones and transparent green for the cover. The fixing mechanisms are in RAL 7016.
- Material: self-extinguishing, **halogen free** insulating plastic (fire resistant and very high temperature withstand).
- Other characteristics: cable gland drilling zone, stainless steel screws and the door can be lead sealed.

2. Tap-off units from 160 to 400 A are made of sheet steel (C)

- Colour: RAL 9001 white for the casing, RAL 9005 black for the grip zones (100 % polyester paint).
- Material: galvanised sheet steel.
- 400 A tap-off units can be only installed on straight lengths ≥ 500 A.
- Other characteristics:
 - removable cover with hinges enabling opening up to 120°, vertically bevelled cover with double bends for enhanced rigidity, polyurethane gaskets
 - equipped with cable-gland plates marked every 25 mm and designed for maximum access.

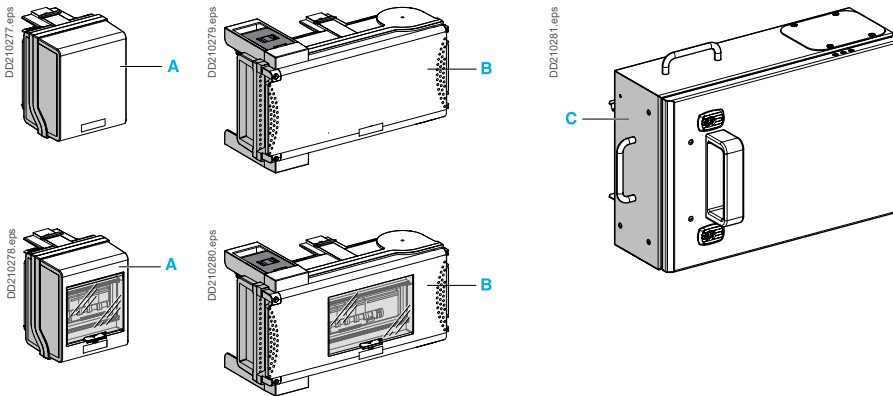

D

Description

Tap-off units

From 100 to 1000 A - Specific description

Description of the Classic offer

Tap-off units for circuit breakers (not included)

Tap-off unit covers can be lead sealed to restrict circuit breaker switching by unauthorised persons.

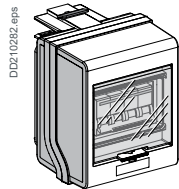

Connector for modular devices

Type CM

This connector can be equipped with most modular devices (18 mm wide) of the Acti 9 type:

- rated current: 32 A
- capacity: 5 modules
- with a window in front for visual and physical access to the devices.

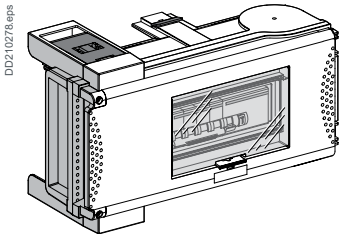

Tap-off units, with isolators, for modular devices

Type SM.8

These tap-off units accept most modular devices of the Acti9 type available in multiples of 18 mm wide modules.

They have a window in front for visual and physical access to the devices. Two ratings are available:

- rated current 63 A for eight modules
- rated current 100 A for twelve modules (can accept C120 circuit breakers).

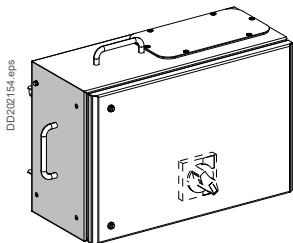

Tap-off units for NG type modular devices

Type SM.13

These tap-off units are equipped with a DIN rail and upstream connections to accept a NG circuit breaker.

The device is operated by a rotary handle that restricts door opening with the circuit breaker in "On" position.

- rated current: 160 A
- capacity: 13 modules (accepts NG125 or NG160 devices equipped with Vigi modules).

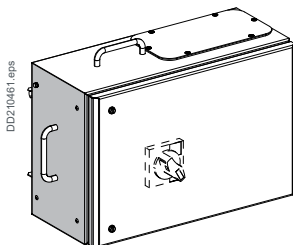

Tap-off units for Compact NSX circuit breaker

Type DC

These tap-off units are equipped with mounting plates and upstream connections for Compact NSX circuit breakers:

- rated current: 100 to 400 A – N, H or L versions
- fixed, front connection, rotary handle
- for Compact NSX + Vigi module, use tap-off units for measurements and metering.
- 400 A tap-off units can be only installed on straight lengths > 400 A.

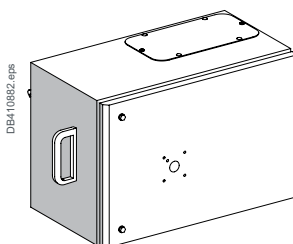

Tap-off units for Compact NSXm circuit breaker

Type DM

These tap-off units are equipped with mounting plates and upstream connections for Compact NSXm circuit breakers:

- rated current: 160 A – N, H or L versions
- fixed, front connection, rotary handle.

Description

Tap-off units

From 100 to 1000 A - Specific description

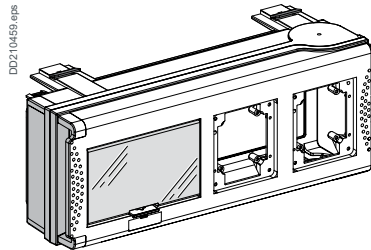
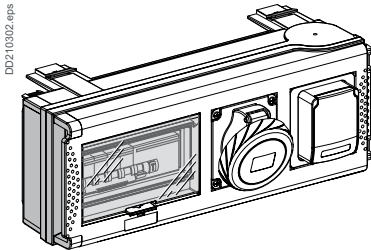

Tap-off units with or for power sockets (circuit breakers not included)

Type CP

Tap-off unit covers can be lead sealed to restrict circuit breaker switching by unauthorised persons.

Canalis 32 A tap-off unit for power sockets

For the supply of portable loads equipped with household or industrial plugs in a garage, maintenance workshop, laboratory, battery charging room, etc. For installation on trunking mounted on a wall for better access. For easy access, install on trunking mounted at an appropriate height on the wall. Flexibility, upgradeability: positioned as close as possible to the loads, extension leads are not required.

Degree of protection: IP55, IK08.

Protection of persons: IPxxB, earth-leakage protection.

Rated current: 32 A

Capacity: 8 modules in multiples of 18 mm wide

Two versions are available:

- pre-equipped with 2 PK or PratiKa power sockets
- customisable:
 - two 90 x 100 mm openings for PK-type (screw connections) or PratiKa (fast and reliable connection without stripping) industrial or household sockets
 - direct mounting for industrial IEC 16 A 5P or IEC 32 A 3, 4 or 5P sockets
 - mounting on a 65 x 85 mm clip-on adapter plate for industrial IEC 16 A 3P or 5P and household 10/16 A 2P + PE sockets.

Tap-off units for fuses (not included)

1. Tap-off unit with fuse holders

Type CN, CF, CG

This tap-off unit exists in three versions:

- for NF 10 x 38 fuses
- for BS type 88 A1 fuses
- for DIN type Neozed E14 fuses.

2a and 2b Tap-off units, with isolator, for fuses

Type SN, SF, SG, SD, SE

There are two types of tap-off units:

Plastic tap-off units (2a) equipped with fuse holders for:

- NF 50 to 100 A cylindrical fuses
- BS 32 to 80 A screw fuses
- DIN 25 to 63 A screw fuses
- 100 A blade-type fuses.

Sheet-metal tap-off units (2b) equipped with fuse holders for 160 to 400 A blade-type fuses.

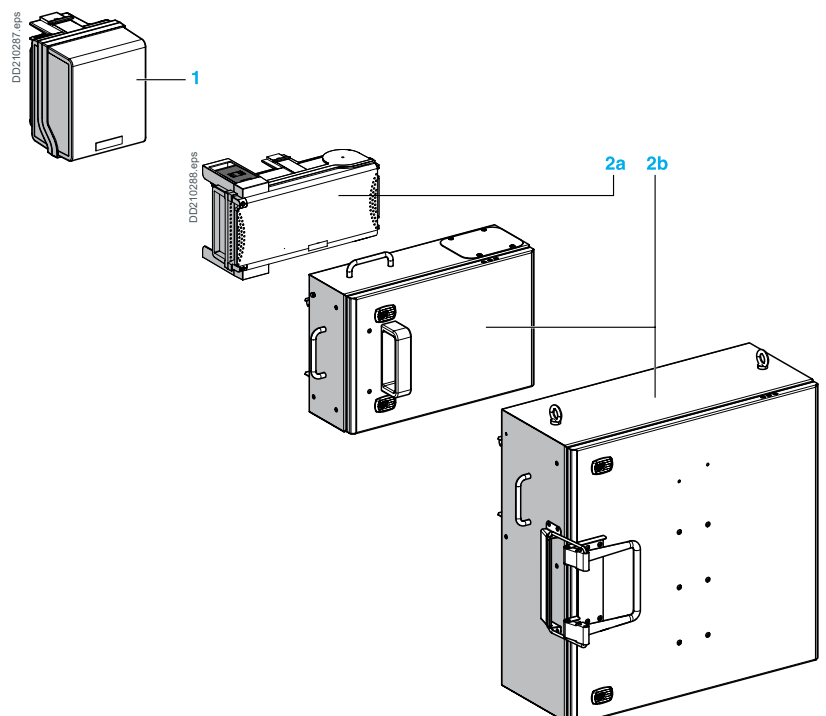

Description

Compatibility of tap-off units and busbar trunkings

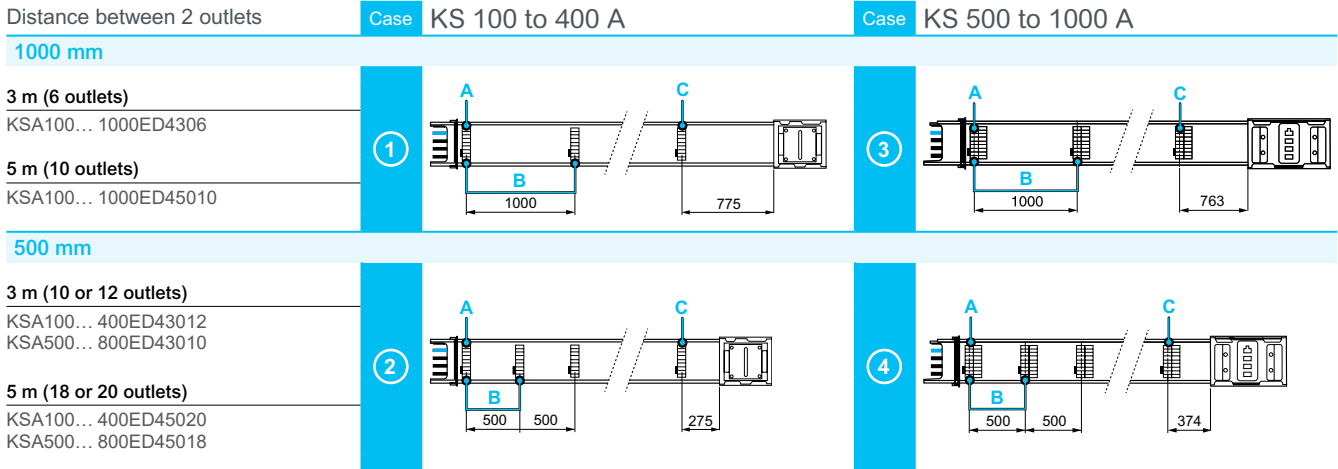

	Case	KS 100 to 400 A - Mountings available on:			Case	KS 500 to 1000 A - Mountings available on:		
		A 1st outlet	B 2 consecutive outlets	C Last outlet		A 1st outlet	B 2 consecutive outlets	C Last outlet
 W* = 135 mm	1	●	■	●	3	●	■	●
	2	●	■	●	4	●	■	●
 W = 434 mm	1	●	■	●	3	●	■	●
	2	●	■	X	4	●	■	X
 W = 357 mm	1	●	■	●	3	●	■	●
	2	●	■	●	4	●	■	●
 W = 444 mm	1	●	■	●	3	●	■	●
	2	●	■	X	4	●	■	X
 W = 450 mm	1	X	■	●	3	●	■	●
	2	X	■	X	4	●	■	X
 W = 500 mm	1	X	■	●	3	●	■	●
	2	X	△	X	4	●	△	X
 W = 600 mm	1	X	■	●	3	●	■	●
	2	X	△	X	4	●	△	X
 W = 600 mm	1	Impossible to fit a 400A tap-off unit on a busway 100 to 400 A			3	●	■	●
	2				4	●	△	X
 W = 700 mm	1	Impossible to fit a 400A tap-off unit on a busway 100 to 400 A			3	●	■	X
	2				4	●	△	X

* W = width of the tap-off unit

- The tap-off unit can be mounted at this position
- The right outlet is available for another tap-off unit
- △ The right outlet is hidden by the tap-off unit
- X Impossible to mount this tap-off unit at this position

Offer overview

Busbar ratings (A)

100	160	250	400	500	630	800	1000
-----	-----	-----	-----	-----	-----	-----	------

Feed units

Mounted on the busway

Without line protection - 3L+N+PE

Right mounting	KSA100AB4	KSA250AB4	KSA250AB4	KSA400AB4	KSA630ABD4	KSA630ABD4	KSA1000ABD4	KSA1000ABD4
Left mounting	KSA100AB4	KSA250AB4	KSA250AB4	KSA400AB4	KSA630ABG4	KSA630ABG4	KSA1000ABG4	KSA1000ABG4
Central mounting	KSA250ABT4	KSA250ABT4	KSA250ABT4	KSA400ABT4	KSA630ABT4	KSA630ABT4	KSA1000ABT4	KSA1000ABT4

Straight lengths

Horizontal mounting for distribution

With Standard density outlets - 3L+N+PE

3000 mm (6 outlets)	KSA100ED4306	KSA160ED4306	KSA250ED4306	KSA400ED4306	KSA500ED4306	KSA630ED4306	KSA800ED4306	KSA1000ED4306
3000 mm (7 outlets)	-	-	-	-	-	KSA630ED4307	-	-
5000 mm (10 outlets)	KSA100ED45010	KSA160ED45010	KSA250ED45010	KSA400ED45010	KSA500ED45010	KSA630ED45010	KSA800ED45010	KSA1000ED45010
5000 mm (11 outlets)	-	-	-	-	-	KSA630ED45011	-	-



With High density outlets - 3L+N+PE

3000 mm (12 or 10 outlets)	KSA100ED43012	KSA160ED43012	KSA250ED43012	KSA400ED43012	KSA500ED43010	KSA630ED43010	KSA800ED43010	-
5000 mm (20 or 18 outlets)	KSA100ED45020	KSA160ED45020	KSA250ED45020	KSA400ED45020	KSA500ED45018	KSA630ED45018	KSA800ED45018	-

Change direction elements

Elbows

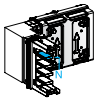
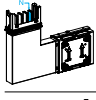
To turn at 90° (edgewise position) - 3L+N+PE

	165 x 165				290 x 290			
	KSA250DLC401	KSA250DLC401	KSA250DLC401	KSA400DLC401	KSA630DLC401	KSA630DLC401	KSA1000DLC401	KSA1000DLC401
	250 x 250				290 x 290			
	KSA250DLE401	KSA250DLE401	KSA250DLE401	KSA400DLE401	KSA630DLE401	KSA630DLE401	KSA1000DLE401	KSA1000DLE401
	250 x 250				290 x 290			
	KSA250DLF401	KSA250DLF401	KSA250DLF401	KSA400DLF401	KSA630DLF401	KSA630DLF401	KSA1000DLF401	KSA1000DLF401

Fixing brackets and supports

For horizontal installation

Fixing brackets

Universal fixing brackets	KSB400ZF1	KSB400ZF1	KSB400ZF1	KSB400ZF1	KSB1000ZF1	KSB1000ZF1	KSB1000ZF1	KSB1000ZF1
Rear fixing bracket	KSA80EZ5	KSA80EZ5	KSA80EZ5	KSA80EZ5	KSA80EZ5	KSA80EZ5	KSA80EZ5	KSA80EZ5

Supports

Cantilever Arm 200 mm	KFBCA81200	KFBCA81200	KFBCA81200	KFBCA81200	KFBCA81200	KFBCA81200	KFBCA81200	KFBCA81200
Cantilever Arm 300 mm	KFBCA81300	KFBCA81300	KFBCA81300	KFBCA81300	KFBCA81300	KFBCA81300	KFBCA81300	KFBCA81300
Pendant kits	KSB400ZFKP1	KSB400ZFKP1	KSB400ZFKP1	KSB400ZFKP1	KSB1000ZFKP1	KSB1000ZFKP1	KSB1000ZFKP1	KSB1000ZFKP1

Accessories

For current KS offer

IP kits

IP55 blanking plates for outlets	KSB400ZB1	KSB400ZB1	KSB400ZB1	KSB400ZB1	KSB1000ZB1	KSB1000ZB1	KSB1000ZB1	KSB1000ZB1
Sprinkler proofing kit	KSB400ZB2	KSB400ZB2	KSB400ZB2	KSB400ZB2	KSB1000ZB2	KSB1000ZB2	KSB1000ZB2	KSB1000ZB2
End covers	KSA400AF1	KSA400AF1	KSA400AF1	KSA400AF1	KSA1000AF1	KSA1000AF1	KSA1000AF1	KSA1000AF1

Sealing kits

For screws	KSB1000ZP1	KSB1000ZP1	KSB1000ZP1	KSB1000ZP1	KSB1000ZP1	KSB1000ZP1	KSB1000ZP1	KSB1000ZP1
For outlets	KSB1000ZP2	KSB1000ZP2	KSB1000ZP2	KSB1000ZP2	KSB1000ZP2	KSB1000ZP2	KSB1000ZP2	KSB1000ZP2

Joint blocks - 3L+N+PE

Electrical and mechanical jointing units	KSA250ZJ4	KSA250ZJ4	KSA250ZJ4	KSA400ZJ4	KSA630ZJ4	KSA630ZJ4	KSA1000ZJ4	KSA1000ZJ4
--	------------------	------------------	------------------	------------------	------------------	------------------	-------------------	-------------------

"KS.....": Reference specifically adapted to the rating of the busbar trunking

"KS.....": Compatible reference with the rating of the busbar trunking

Offer overview

Busbar ratings (A)

Polarity	100	160	250	400	500	630	800	1000
----------	-----	-----	-----	-----	-----	-----	-----	------

Connectors & Tap-off units *

Disconnection by unplugging the connector

Delivered equipped with a fuse holder

For BS/NF/NZ fuses	16 A	3L+PEN	KSB16CN5	KSB16CN5
	20 A		KSB20CG5	KSB20CG5
	32 A		KSB32CF5	KSB32CF5

Delivered equipped with a DIN rail

For 5 modular devices 18 mm	32 A	3L+N+PE	KSB32CM55	KSB32CM55
For 8 modular devices 18 mm and power sockets	32 A		KSB32CP	KSB32CP
			KSB32CP15F	KSB32CP15F
			KSB32CP15D	KSB32CP15D
			KSB32CP35	KSB32CP35
			KSB32CP11F	KSB32CP11F
		KSB32CP11D	KSB32CP11D	

Disconnection by opening the door

Delivered equipped with a fuse holder

For BS fuses	32 A	3L+N+PE	KSB32SG4	KSB32SG4
	80 A		KSB80SG4	KSB80SG4
	160 A		KSB160SG4	KSB160SG4
For NF fuses (Cylindrical)	50 A	3L+N+PE	KSB50SF4	KSB50SF4
		3L+PEN	KSB50SF5	KSB50SF5
	100 A	3L+N+PE	KSB100SF4	KSB100SF4
		3L+PEN	KSB100SF5	KSB100SF5
For NZ/DZ fuses	25 A	3L+N+PE	KSB25SD4	KSB25SD4
		3L+PEN	KSB25SD5	KSB25SD5
	50 A	3L+N+PE	KSB50SN4	KSB50SN4
		3L+PEN	KSB50SN5	KSB50SN5
	63 A	3L+N+PE	KSB63SD4	KSB63SD4
		3L+PEN	KSB63SD5	KSB63SD5
For Blade-type fuses	100 A	3L+N+PE	KSB100SE4	KSB100SE4
		3L+PEN	KSB100SE5	KSB100SE5
	160 A	3L+N+PE	KSB160SF4	KSB160SF4
			KSB160SE4	KSB160SE4
		3L+PEN	KSB160SF5	KSB160SF5
			KSB160SE5	KSB160SE5
	250 A	3L+N+PE	KSB250SE4	KSB250SE4
		3L+PEN	KSB250SE5	KSB250SE5
	400 A	3L+N+PE	-	KSB400SE4
		3L+PEN	-	KSB400SE5

Delivered equipped with a DIN rail

For 18 mm modular devices	63 A	3L+N+PE	KSB63SM48	KSB63SM48
	8 mod.	3L+PEN	KSB63SM58	KSB63SM58
		100 A	3L+N+PE	KSB100SM412
	12 mod.	3L+PEN	KSB100SM512	KSB100SM512

Switching with a rotary handle located on the door

Delivered equipped with a mounting plate for 1 circuit breaker

For NG circuit breaker	160 A	3L+N+PE	KSB160SM413	KSB160SM413
		3L+PEN	KSB160SM513	KSB160SM513
For NSX circuit breaker 4P	160 A	3L+N+PE	KSB160DC4	KSB160DC4
	250 A		KSB250DC4	KSB250DC4
	400 A		-	KSB400DC4
For NSX circuit breaker 3P	160 A	3L+PEN	KSB160DC5	KSB160DC5
	250 A		KSB250DC5	KSB250DC5
	400 A		-	KSB400DC5
For NSXm circuit breaker	160 A	3L+N+PE	KSB160DM4	KSB160DM4
		3L+PEN	KSB160DM5	KSB160DM5

* See compatibility page for mounting limitations

D

Classic offer

Feed units

Right mounting

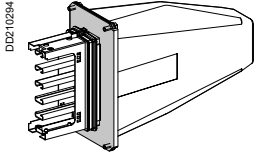

KSA100AB4

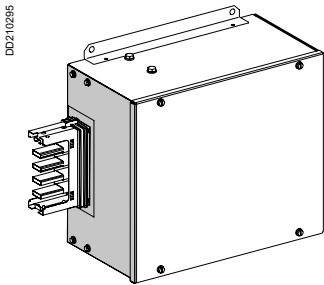

KSA250 and 400 AB4

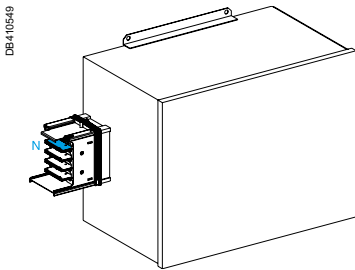

KSA630 and 1000 ABD

Mounted on the busway Without line protection

Cat. n°	KSA100AB4	KSA250AB4	KSA400AB4	KSA630ABD4	KSA1000ABD4
Compatible with	KSA100 to 250	KSA100 to 250	KSA400	KSA500 to 1000	KSA500 to 1000

A in the line (mm)	390	501	501	753	753
--------------------	-----	-----	-----	-----	-----

Rating (A)	100	250	400	630	1000
Polarity	3L + N + PE	3L + N + PE	3L + N + PE	3L + N + PE	3L + N + PE
Phase Diagram					

Cabling					
Protection Type (Not Supplied)	None	None	None	None	None

Input Type	Cable Gland PG29	Alu. plate 300 x 170 x 3	Alu. plate 340 x 208 x 3	Alu. plate 446 x 276 x 3	Alu. plate 446 x 358 x 3
Available Area (mm)	Ø 37.5 mm	240 x 130	280 x 160	386 x 240	386 x 320
Maximum Cable size (mm ²)	Cable max Ø23mm	4 x 240	4 x 300 or 8 x 120	4 x 300 or 8 x 240	12 x 300
Connection	Mechanical lugs (Zinc plated steel)	With Compression Lugs ⁽¹⁾ onto tin-plated aluminum bars	With Compression Lugs ⁽¹⁾ onto tin-plated aluminum bars	With Compression Lugs ⁽¹⁾ onto tin-plated aluminum bars	With Compression Lugs ⁽¹⁾ onto tin-plated aluminum bars
Capability Per Phase	16 mm ²	1 x Ø 13 mm (L) + 1 x Ø 8 mm (PE)	1 x Ø 13 mm (L) + 2 x Ø 11 mm (PE)	3 x Ø 14 mm (L) + 3 x Ø 11 mm (PE)	4 x Ø 15 mm (L) + 4 x Ø 10 mm (PE)

- (1) Not included (1) Not included (1) Not included (1) Not included

Additional Characteristics					
IP	IP55	IP55	IP55	IP55	IP55
Color	White	White	White	White	White
Weight (kg)	1,8	8	11,2	22	25
Selling Unit	1	1	1	1	1
MOQ	1	1	1	1	1

All feed units are supplied with an End cover

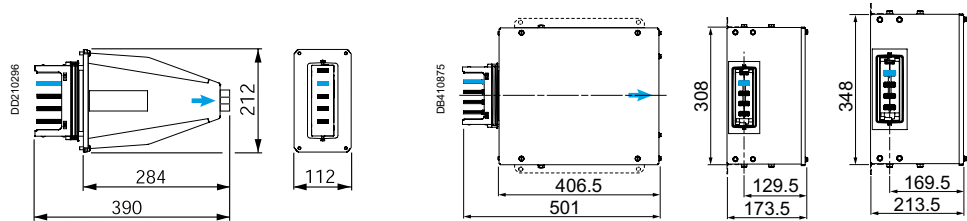

KSA100AB4

KSA250 and 400 AB4

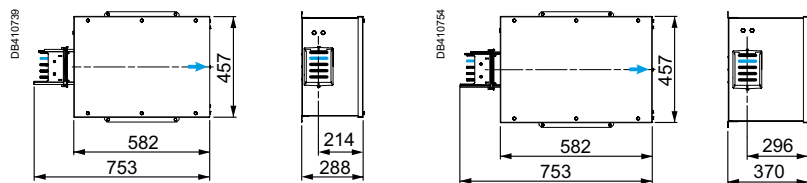

KSA630ABD4

KSA1000ABD4

Classic offer

Feed units

Left mounting

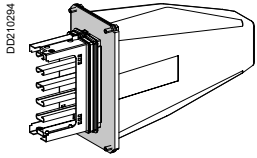

KSA100AB4

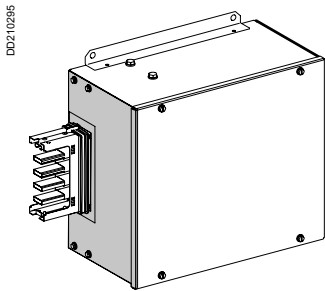

KSA250 and 400 AB4

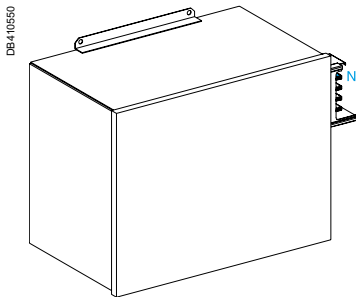

KSA630 and 1000 ABG

Mounted on the busway Without line protection

Cat. n°	KSA100AB4	KSA250AB4	KSA400AB4	KSA630ABG4	KSA1000ABG4
Compatible with	KSA100 to 250	KSA100 to 250	KSA400	KSA500 to 1000	KSA500 to 1000

A in the line (mm)	390	501	501	753	753
--------------------	-----	-----	-----	-----	-----

Rating (A)	100	250	400	630	1000
Polarity	3L + N + PE	3L + N + PE	3L + N + PE	3L + N + PE	3L + N + PE
Phase Diagram					

Cabling

Protection Type (Not Supplied)	None	None	None	None	None
--------------------------------	------	------	------	------	------

Input Type	Cable Gland PG29	Alu. plate 300 x 170 x 3	Alu. plate 340 x 208 x 3	Alu. plate 446 x 276 x 3	Alu. plate 446 x 358 x 3
Available Area (mm)	Ø37.5 mm	240 x 130	280 x 160	386 x 240	386 x 320
Maximum Cable size (mm ²)	Cable max. Ø23 mm	4 x 240	4 x 300 or 8 x 120	4 x 300 or 8 x 240	12 x 300
Connection	Mechanical lugs (Zinc plated steel)	With Compression Lugs ⁽¹⁾ onto tin-plated aluminum bars	With Compression Lugs ⁽¹⁾ onto tin-plated aluminum bars	With Compression Lugs ⁽¹⁾ onto tin-plated aluminum bars	With Compression Lugs ⁽¹⁾ onto tin-plated aluminum bars
Capability Per Phase	16 mm ²	1 x Ø13 mm (L) + 1 x Ø8 mm (PE)	1 x Ø13 mm (L) + 2 x Ø11 mm (PE)	3 x Ø14 mm (L) + 3 x Ø11 mm (PE)	4 x Ø15 mm (L) + 4 x Ø10 mm (PE)

- (1) Not included (1) Not included (1) Not included (1) Not included

Additional Characteristics

IP	IP55	IP55	IP55	IP55	IP55
Color	White	White	White	White	White
Weight (kg)	1,8	8	11,2	23	25
Selling Unit	1	1	1	1	1
MOQ	1	1	1	1	1

All feed units are supplied with an End cover

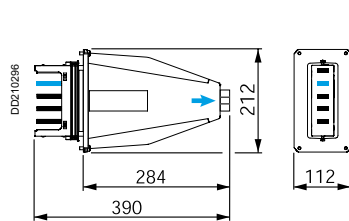

KSA100AB4

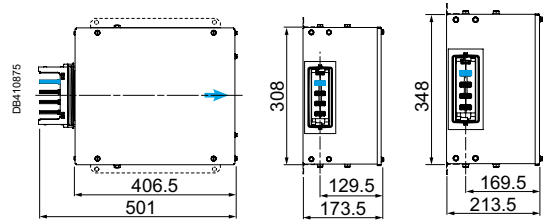

KSA250 and 400 AB4

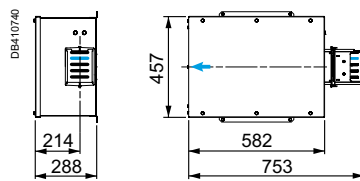

KSA630ABG4

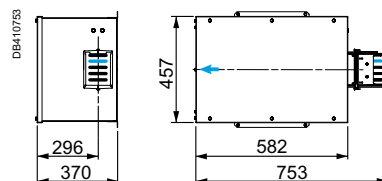

KSA1000ABG4

Classic offer

Feed units

Central mounting

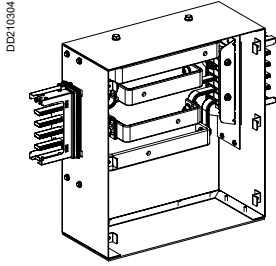

KSA250 and 400 ABT

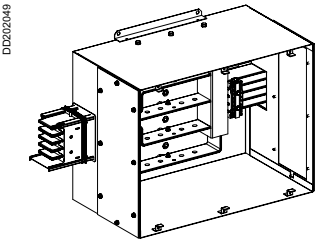

KSA630 and 1000 ABT

Mounted on the busway Without line protection

Cat. n°	KSA250ABT4	KSA400ABT4	KSA630ABT4	KSA1000ABT4
Compatible with	KSA100 to 250	KSA400	KSA500 to 1000	KSA500 to 1000
A in the line (mm)	585	688	1001	1101
Rating (A)	250	400	630	1000
Polarity	3L + N + PE	3L + N + PE	3L + N + PE	3L + N + PE
Phase Diagram				
Cabling				
Protection Type (Not Supplied)	None	None	None	None
Input Type	Alu. plate 390 x 168 x 3	Alu. plate 491 x 208 x 3	2 x Alu. plates 502 x 227 x 3	2 x Alu. plates 552 x 252 x 3
Available Area (mm)	330 x 120	430 x 170	2 x (440 x 180)	2 x (390 x 210)
Maximum Cable size (mm ²)	4 x 240	8 x 240	12 x 300	16 x 300
Connection	With Compression Lugs ⁽¹⁾ onto tin-plated aluminum bars	With Compression Lugs ⁽¹⁾ onto tin-plated aluminum bars	With Compression Lugs ⁽¹⁾ onto tin-plated aluminum bars	With Compression Lugs ⁽¹⁾ onto tin-plated aluminum bars
Capability Per Phase	1 x Ø9 mm (L) + 1 x Ø8 mm (PE)	2 x Ø13 mm (L) + 2 x Ø11 mm (PE)	4 x Ø14 mm (L) + 4 x Ø9 mm (PE)	4 x Ø14 mm (L) + 4 x Ø9 mm (PE)
	(¹) Not included	(¹) Not included	(¹) Not included	(¹) Not included

Additional Characteristics

IP	IP55	IP55	IP55	IP55
Color	White	White	White	White
Weight (kg)	13	16,4	32	43
Selling Unit	1	1	1	1
MOQ	1	1	1	1

All Central feed units are supplied with Two End covers

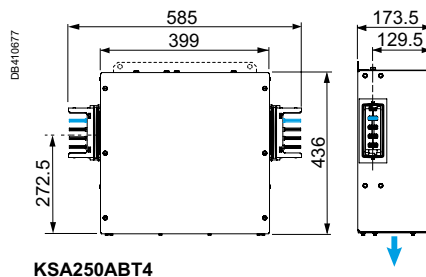

KSA250ABT4

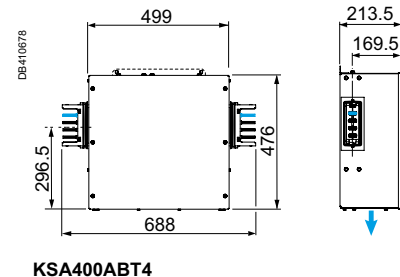

KSA400ABT4

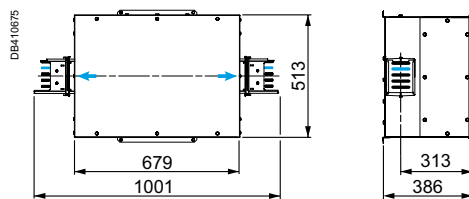

KSA630ABT4

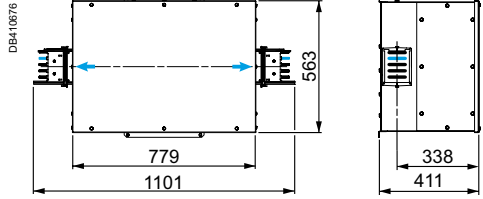

KSA1000ABT4

D

Classic offer

Straight lengths

With Standard density outlets - 3 m

DB410751

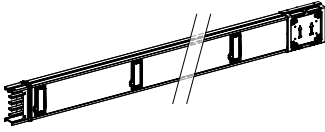

KSA100 to 400 ED •30

For Distribution Horizontal mounting

Cat. n°	KSA100ED4306	KSA160ED4306	KSA250ED4306	KSA400ED4306
Compatible with	KSA100 to 250	KSA100 to 250	KSA100 to 250	KSA400
A in the line (mm)	3000	3000	3000	3000
Rating (A)	100	160	250	400
Polarity	3L + N + PE	3L + N + PE	3L + N + PE	3L + N + PE

Characteristics

Number	6	6	6	6
Of Outlet(s)				
Outlet(s) Position	3 on each side	3 on each side	3 on each side	3 on each side
Distance Between 1000	1000	1000	1000	1000
Outlets (mm)				
Fire Barrier	No	No	No	No
Fire Barrier Position	-	-	-	-

Additional Characteristics

IP	IP55	IP55	IP55	IP55
Color	White	White	White	White
Weight (kg)	12,1	13,4	15,7	20,4
Selling Unit	1	1	1	1
MOQ	1	1	1	1

With Standard density outlets - 3 m

DB410752

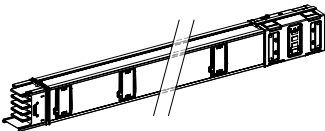

KSA500 to 1000 ED •30

For Distribution Horizontal mounting

Cat. n°	KSA500ED4306	KSA630ED4306	KSA800ED4306	KSA1000ED4306
Compatible with	KSA500 to 1000	KSA500 to 1000	KSA500 to 1000	KSA500 to 1000
A in the line (mm)	3000	3000	3000	3000
Rating (A)	500	630	800	1000
Polarity	3L + N + PE	3L + N + PE	3L + N + PE	3L + N + PE

Characteristics

Number	6	6	6	6
Of Outlet(s)				
Outlet(s) Position	3 on each side	3 on each side	3 on each side	3 on each side
Distance Between 1000	1000	1000	1000	1000
Outlets (mm)				
Fire Barrier	No	No	No	No
Fire Barrier Position	-	-	-	-

Additional Characteristics

IP	IP55	IP55	IP55	IP55
Color	White	White	White	White
Weight (kg)	34,9	36,4	43,1	55,2
Selling Unit	1	1	1	1
MOQ	1	1	1	1

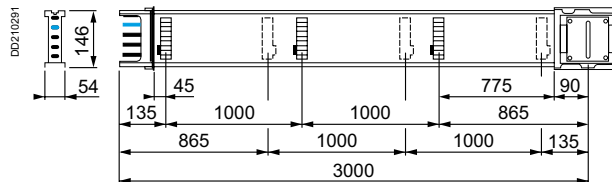

KSA100 to 400 ED •30

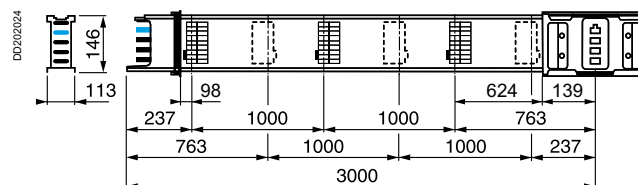

KSA500 to 1000 ED •30

Classic offer

Straight lengths

With Standard density outlets - 5 m

DB410751

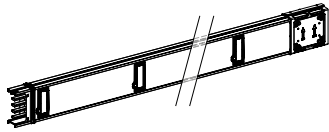

KSA100 to 400 ED •50

For Distribution
Horizontal mounting

Cat. n°	KSA100ED45010	KSA160ED45010	KSA250ED45010	KSA400ED45010
Compatible with	KSA100 to 250	KSA100 to 250	KSA100 to 250	KSA400
A in the line (mm)	5000	5000	5000	5000
Rating (A)	100	160	250	400
Polarity	3L + N + PE	3L + N + PE	3L + N + PE	3L + N + PE

Characteristics				
Number	10	10	10	10
Of Outlet(s)				
Outlet(s) Position	5 on each side	5 on each side	5 on each side	5 on each side
Distance Between	1000	1000	1000	1000
Outlets (mm)				
Fire Barrier	No	No	No	No
Fire Barrier Position	-	-	-	-

Additional Characteristics				
IP	IP55	IP55	IP55	IP55
Color	White	White	White	White
Weight (kg)	19,2	21,4	24,9	32,85
Selling Unit	1	1	1	1
MOQ	1	1	1	1

With Standard density outlets - 5 m

DB410752

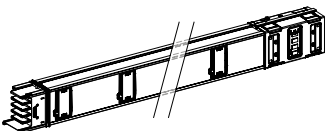

KSA500 to 1000 ED •50

For Distribution
Horizontal mounting

Cat. n°	KSA500ED45010	KSA630ED45010	KSA800ED45010	KSA1000ED45010
Compatible with	KSA500 to 1000	KSA500 to 1000	KSA500 to 1000	KSA500 to 1000
A in the line (mm)	5000	5000	5000	5000
Rating (A)	500	630	800	1000
Polarity	3L + N + PE	3L + N + PE	3L + N + PE	3L + N + PE

Characteristics				
Number	10	10	10	10
Of Outlet(s)				
Outlet(s) Position	5 on each side	5 on each side	5 on each side	5 on each side
Distance Between	1000	1000	1000	1000
Outlets (mm)				
Fire Barrier	No	No	No	No
Fire Barrier Position	-	-	-	-

Additional Characteristics				
IP	IP55	IP55	IP55	IP55
Color	White	White	White	White
Weight (kg)	54,5	58,2	69,2	89,5
Selling Unit	1	1	1	1
MOQ	1	1	1	1



KSA100 to 400 ED •50

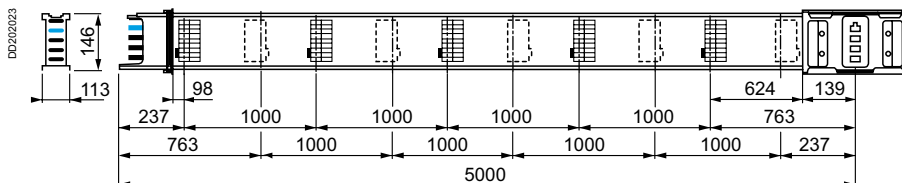

KSA500 to 1000 ED •50

Classic offer

Straight lengths

With High density outlets - 3 m

DB410751

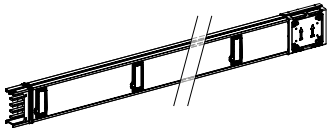

KSA100 to 400 ED •30

For Distribution
Horizontal mounting

Cat. n°	KSA100ED43012	KSA160ED43012	KSA250ED43012	KSA400ED43012
Compatible with	KSA100 to 250	KSA100 to 250	KSA100 to 250	KSA400
A in the line (mm)	3000	3000	3000	3000
Rating (A)	100	160	250	400
Polarity	3L + N + PE	3L + N + PE	3L + N + PE	3L + N + PE

Characteristics				
Number	12	12	12	12
Of Outlet(s)				
Outlet(s) Position	6 on each side	6 on each side	6 on each side	6 on each side
Distance Between	500	500	500	500
Outlets (mm)				
Fire Barrier	No	No	No	No
Fire Barrier Position	-	-	-	-

Additional Characteristics				
IP	IP55	IP55	IP55	IP55
Color	White	White	White	White
Weight (kg)	12,1	13,4	15,7	20
Selling Unit	1	1	1	1
MOQ	1	1	1	1

With High density outlets - 3 m

DB410752

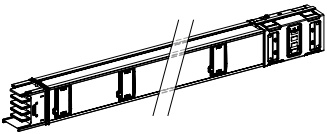

KSA500 to 800 ED •30

For Distribution
Horizontal mounting

Cat. n°	KSA500ED43010	KSA630ED4307	KSA630ED43010	KSA800ED43010
Compatible with	KSA500 to 1000	KSA500 to 1000	KSA500 to 1000	KSA500 to 1000
A in the line (mm)	3000	3000	3000	3000
Rating (A)	500	630	630	800
Polarity	3L + N + PE	3L + N + PE	3L + N + PE	3L + N + PE

Characteristics				
Number	10	7	10	10
Of Outlet(s)				
Outlet(s) Position	5 on each side	One side 5 & other side 2	5 on each side	5 on each side
Distance Between	500 or 750	500 or 1750	500 or 750	500 or 750
Outlets (mm)				
Fire Barrier	No	No	No	No
Fire Barrier Position	-	-	-	-

Additional Characteristics				
IP	IP55	IP55	IP55	IP55
Color	White	White	White	White
Weight (kg)	34,9	36,4	36,4	43,1
Selling Unit	1	1	1	1
MOQ	1	1	1	1

DD230189

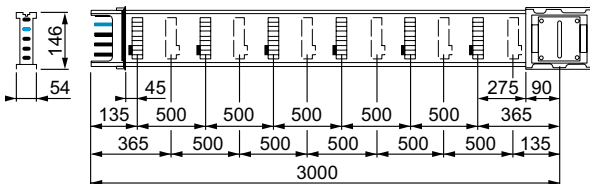

KSA100 to 400 ED •30

DB410812

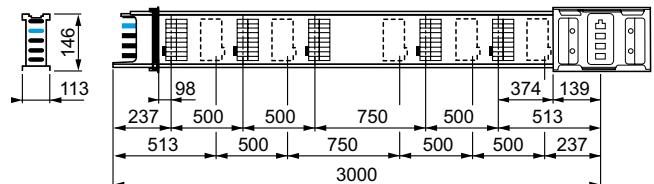

KSA500 to 800 ED •30

DB411595

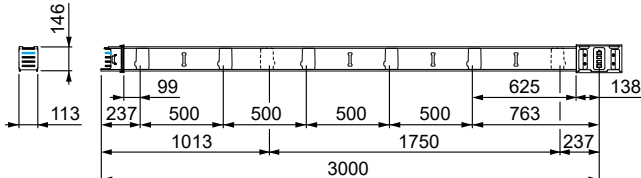

KSA630ED4307

Classic offer

Straight lengths

With High density outlets - 5 m

DB410751

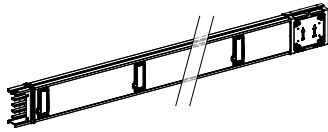

KSA100 to 400 ED •50

For Distribution
Horizontal mounting

Cat. n°	KSA100ED45020	KSA160ED45020	KSA250ED45020	KSA400ED45020
Compatible with	KSA100 to 250	KSA100 to 250	KSA100 to 250	KSA400
A in the line (mm)	5000	5000	5000	5000
Rating (A)	100	160	250	400
Polarity	3L + N + PE	3L + N + PE	3L + N + PE	3L + N + PE

Characteristics				
Number Of Outlet(s)	20	20	20	20
Outlet(s) Position	10 on each side	10 on each side	10 on each side	10 on each side
Distance Between Outlets (mm)	500	500	500	500
Fire Barrier Position	No	No	No	No
Fire Barrier	-	-	-	-

Additional Characteristics				
IP	IP55	IP55	IP55	IP55
Color	White	White	White	White
Weight (kg)	19,2	21,4	25,2	32,85
Selling Unit	1	1	1	1
MOQ	1	1	1	1

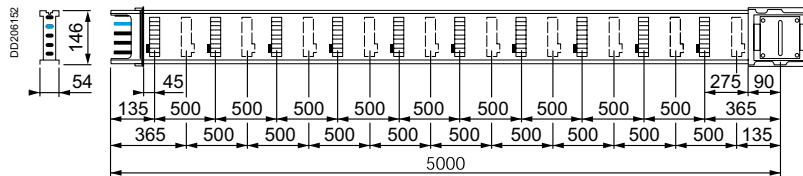

KSA100 to 400 ED •50

D

Classic offer

Straight lengths

With High density outlets - 5 m

DB41075Z

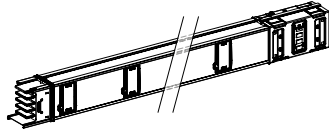

KSA500 to 800 ED -50

**For Distribution
Horizontal mounting**

Cat. n°	KSA500ED45018	KSA630ED45011	KSA630ED45018	KSA800ED45018
Compatible with	KSA500 to 1000	KSA500 to 1000	KSA500 to 1000	KSA500 to 1000
A in the line (mm)	5000	5000	5000	5000
Rating (A)	500	630	630	800
Polarity	3L + N + PE	3L + N + PE	3L + N + PE	3L + N + PE

Characteristics

Number Of Outlet(s)	18	11	18	18
Outlet(s) Position	9 on each side	One side 9 & other side 2	9 on each side	9 on each side
Distance Between Outlets (mm)	500 or 750	500 or 2000	500 or 750	500 or 750
Fire Barrier	No	No	No	No
Fire Barrier Position	-	-	-	-

Additional Characteristics

IP	IP55	IP55	IP55	IP55
Color	White	White	White	White
Weight (kg)	54,5	36,4	58,2	69,2
Selling Unit	1	1	1	1
MOQ	1	1	1	1

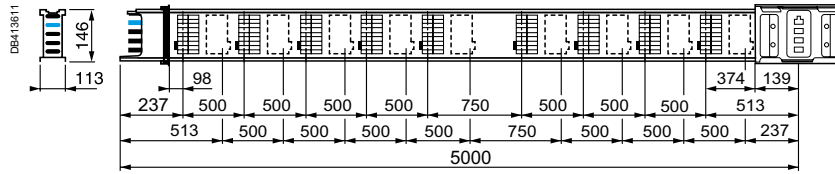

KSA500 to 800 ED -50

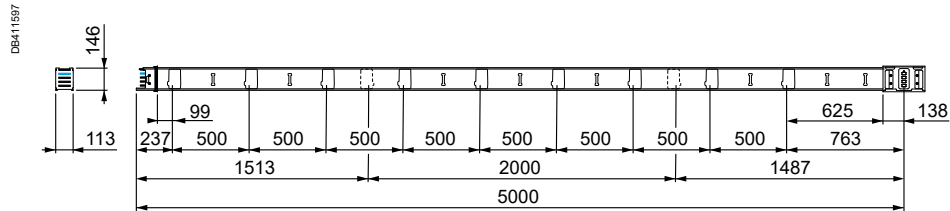

KSA630ED45011

Classic offer

Change direction elements

Elbows

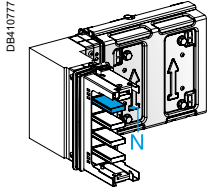

KSA100 to 400 DLC 401

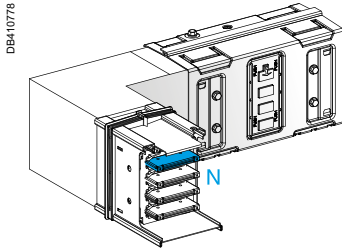

KSA500 to 1000 DLC 401

To turn Right or Left at 90° (Edgewise position) Fixed dimensions

Cat. n°	KSA250DLC401	KSA400DLC401	KSA630DLC401	KSA1000DLC401
Compatible with	KSA100 to 250	KSA400	KSA500 to 1000	KSA500 to 1000
A in the line (mm)	330	330	580	580
Rating (A)	250	400	630	1000
Polarity	3L + N + PE	3L + N + PE	3L + N + PE	3L + N + PE

Dimensions				
A (mm)	165	165	290	290
B (mm)	165	165	290	290
C (mm)	-	-	-	-
D (mm)	-	-	-	-
Fire Barrier	No	No	No	No
Fire Barrier Position	-	-	-	-

Additional Characteristics				
IP	IP55	IP55	IP55	IP55
Color	White	White	White	White
Weight (kg)	3,6	3,9	8,2	15
Selling Unit	1	1	1	1
MOQ	1	1	1	1

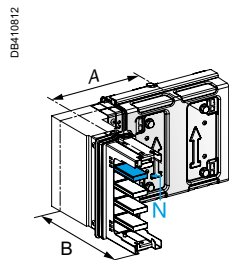

KSA100 to 400 DLC 401

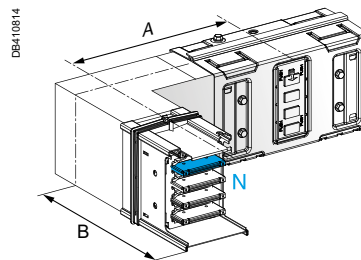

KSA500 to 1000 DLC 401

Classic offer

Change direction elements

Elbows

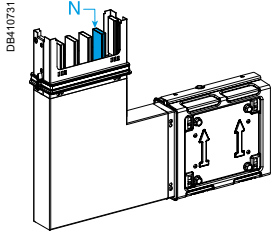

KSA100 to 400 DLE 401

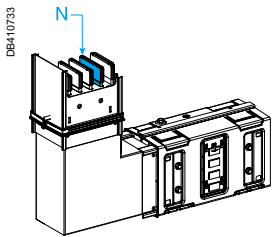

KSA500 to 1000 DLE 401

**To go Upward at 90° (Edgewise position)
Fixed dimensions**

Cat. n°	KSA250DLE401	KSA400DLE401	KSA630DLE401	KSA1000DLE401
Compatible with	KSA100 to 250	KSA400	KSA500 to 1000	KSA500 to 1000
A in the line (mm)	500	500	580	580
Rating (A)	250	400	630	1000
Polarity	3L + N + PE	3L + N + PE	3L + N + PE	3L + N + PE

Dimensions				
A (mm)	250	250	290	290
B (mm)	250	250	290	290
C (mm)	-	-	-	-
D (mm)	-	-	-	-
Fire Barrier	No	No	No	No
Fire Barrier Position	-	-	-	-

Additional Characteristics				
IP	IP55	IP55	IP55	IP55
Color	White	White	White	White
Weight (kg)	2,6	5,8	10,5	13,5
Selling Unit	1	1	1	1
MOQ	1	1	1	1

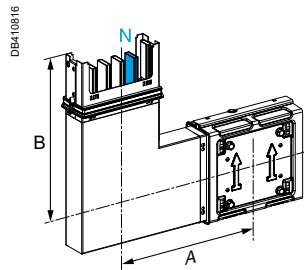

KSA100 to 400 DLE 401

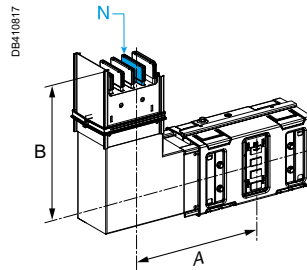

KSA500 to 1000 DLE 401

Classic offer

Change direction elements

Elbows

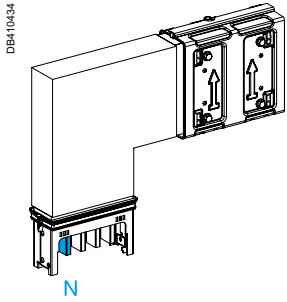

KSA100 to 400 DLF 401

To go Downward at 90° (Edgewise position)
Fixed dimensions

Cat. n°	KSA250DLF401	KSA400DLF401	KSA630DLF401	KSA1000DLF401
Compatible with	KSA100 to 250	KSA400	KSA500 to 1000	KSA500 to 1000
A in the line (mm)	500	500	580	580
Rating (A)	250	400	630	1000
Polarity	3L + N + PE	3L + N + PE	3L + N + PE	3L + N + PE

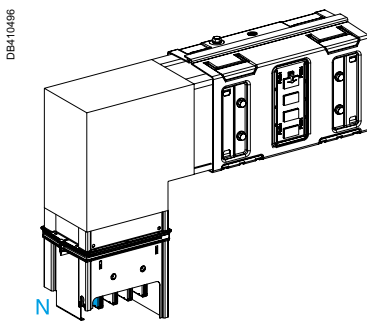

KSA500 to 1000 DLF 401

Dimensions				
A (mm)	250	250	290	290
B (mm)	250	250	290	290
C (mm)	-	-	-	-
D (mm)	-	-	-	-
Fire Barrier	No	No	No	No
Fire Barrier Position	-	-	-	-

Additional Characteristics				
IP	IP55	IP55	IP55	IP55
Color	White	White	White	White
Weight (kg)	2,6	2,9	12	13
Selling Unit	1	1	1	1
MOQ	1	1	1	1

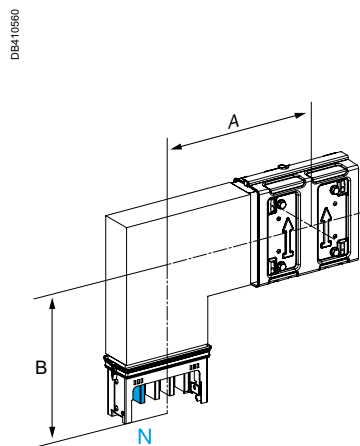

KSA100 to 400 DLF 401

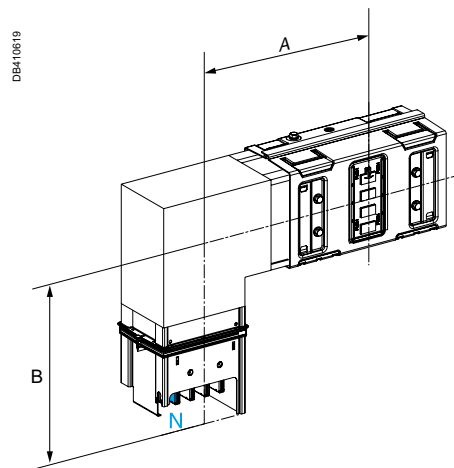

KSA500 to 1000 DLF 401



Classic offer

Fixing brackets and supports

For horizontal installation

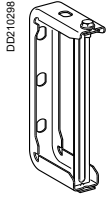

KSB400ZF1

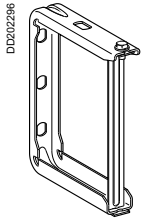

KSB1000ZF1

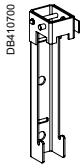

KSA80EZ5

Fixing brackets Universal and Rear fixing brackets

Cat. n°	KSB400ZF1	KSB1000ZF1	KSA80EZ5
Compatible with	KSA100 to 400	KSA500 to 1000	KSA100 to 1000

Rating (A)	400	1000	1000
Polarity	-	-	-

Characteristics

Max load 70kg	Max load 70kg	Max load 50kg
---------------	---------------	---------------

Additional Characteristics

IP	-	-	-
Color	Galvanised	Galvanised	Galvanised
Weight (kg)	0,22	0,42	0,27
Selling Unit	1	1	1
MOQ	10	10	10

Maximum recommended distance between fixings is 3 meters

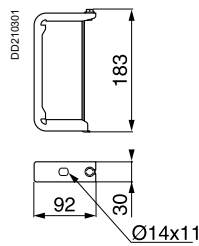

KSB400ZF1

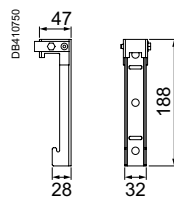

KSA80EZ5

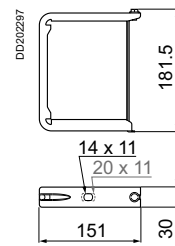

KSB1000ZF1

Classic offer

Fixing brackets and supports

For horizontal installation

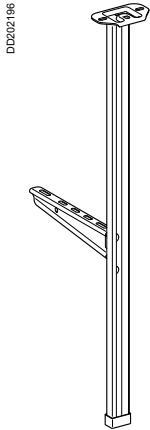

Supports Pendant kits and Cantilever Arms

Cat. n°	KSB400ZFKP1	KSB1000ZFKP1	KFBCA81200	KFBCA81300
Compatible with	KSA100 to 400	KSA500 to 1000	KSA100 to 1000	KSA100 to 1000

Rating (A)	400	1000	1000	1000
Polarity	-	-	-	-

Characteristics

KSB400ZFKP1

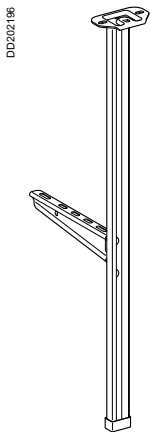

KSB1000ZFKP1

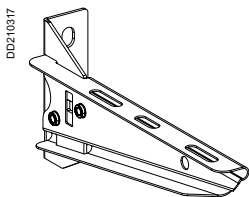

KFBCA81200

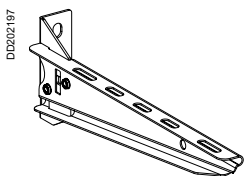

KFBCA81300

-	-	Max. permissible weight: 220 kg	Max. permissible weight: 220 kg
---	---	---------------------------------	---------------------------------

Additional Characteristics

IP	-	-	-	-
Color	Galvanised	Galvanised	Galvanised	Galvanised
Weight (kg)	0,82	2,6	0,45	2,4
Selling Unit	1	1	1	1
MOQ	4	4	4	4

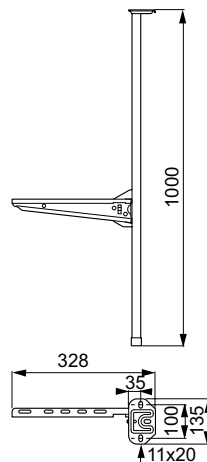

KSB400ZFKP1

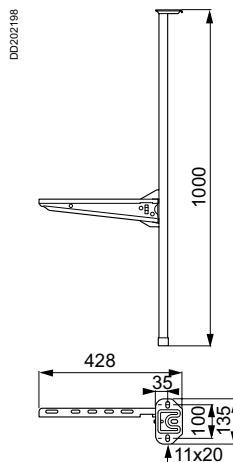

KSB1000ZFKP1

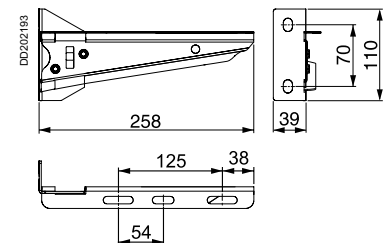

KFBCA81200

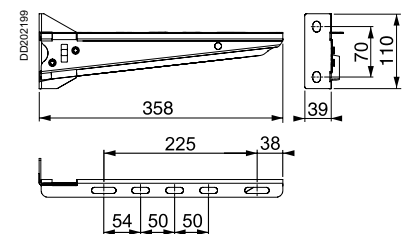

KFBCA81300



Classic offer

Connectors and Tap-off units

Disconnection by unplugging the connector

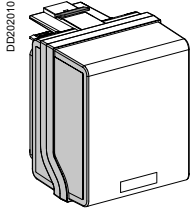

KSB•• CF CN CG 5

Delivered equipped with a fuse holder
For BS/NF/NZ fuses ⁽¹⁾

Cat. n°	KSB16CN5	KSB20CG5	KSB32CF5
Compatible with	KSA100 to 1000	KSA100 to 1000	KSA100 to 1000

Rating (A)	16	20	32
Polarity	3L + N + PE	3L + N + PE	3L + N + PE
Phase Diagram			

Cabling			
Protection Type (Not Supplied)	Fuses NZ - E14	Fuses BS88 - A1	Fuses NF 10 x 38 aM 32A max. Fuses NF 10 x 38 gG 25A max.
Body Material	Plastic	Plastic	Plastic
Cable Output	Cable gland ⁽²⁾	Cable gland ⁽²⁾	Cable gland ⁽²⁾
Available Area (mm ²)	1 x ISO 32 max. Multipolar cable	1 x ISO 32 max. Multipolar cable	1 x ISO 32 max. Multipolar cable
Connection	Terminals on the fuse holder	Brass clamps	Brass clamps
Maximum Rigid Cable Size (mm ²)	6	6	6
Maximum Flexible Cable Size (mm ²)	10	10	10
	⁽²⁾ Not included	⁽²⁾ Not included	⁽²⁾ Not included

Additional Characteristics			
IP	IP55	IP55	IP55
Color	White	White	White
Weight (kg)	0,85	0,85	0,85
Selling Unit	1	1	1
MOQ	1	1	1

⁽¹⁾ Not included

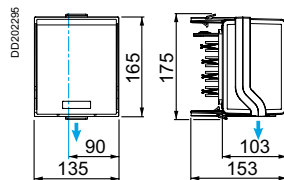

KSB•• CF CN CG 5

Classic offer

Connectors and Tap-off units

Disconnection by unplugging the connector

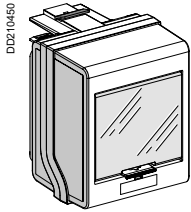

KSB32CM55

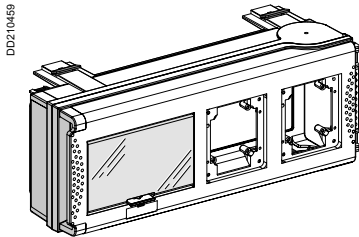

KSB32CP

Delivered equipped with a DIN rail
For 18 mm modular devices ⁽¹⁾. CM: without Power sockets. CP: for Pratika Power sockets

Cat. n°	KSB32CM55	KSB32CP
Compatible with	KSA100 to 1000	KSA100 to 1000

Rating (A)	32	32
Polarity	3L + N + PE	3L + N + PE
Phase Diagram		

Cabling		
Protection Type (Not Supplied)	5 modules 18 mm	8 modules 18 mm

Body Material	Plastic	Plastic
Cable Output	Cable gland ⁽²⁾	For 2 Pratika Power sockets

Available Area (mm)	1 x ISO 32 max. Multipolar cable	-
---------------------	----------------------------------	---

Connection	Acti9 Terminals	Patrika Power sockets
------------	-----------------	-----------------------

Maximum Rigid Cable Size (mm ²)	See Acti9 catalog	See Acti9 and Pratika catalogs
Maximum Flexible Cable Size (mm ²)	See Acti9 catalog	See Acti9 and Pratika catalogs

	Supplied with blanking plate	Supplied with blanking plate
--	------------------------------	------------------------------

⁽²⁾ Not included -

Additional Characteristics		
IP	IP55	IP55
Color	White	White
Weight (kg)	0,65	1,45
Selling Unit	1	1
MOQ	1	1

⁽¹⁾ Not included

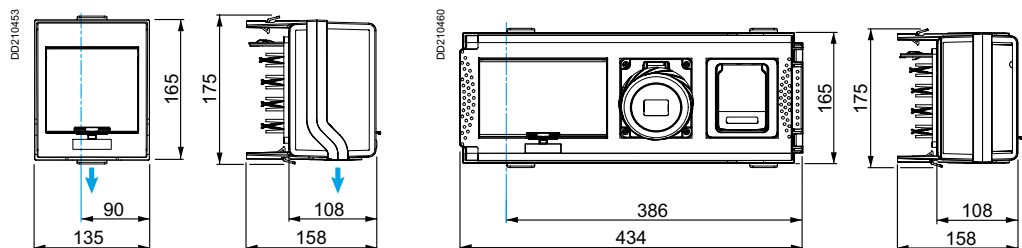

KSB32CM55

KSB32CP



Classic offer

Connectors and Tap-off units

Disconnection by unplugging the connector

DD210456

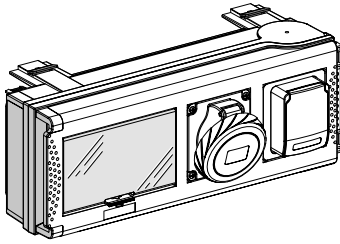

KSB32CP...

Delivered equipped with a DIN rail
For 18 mm modular devices ⁽¹⁾. With Household NF and Industrial sockets

Cat. n°	KSB32CP11F	KSB32CP15F
Compatible with	KSA100 to 1000	KSA100 to 1000

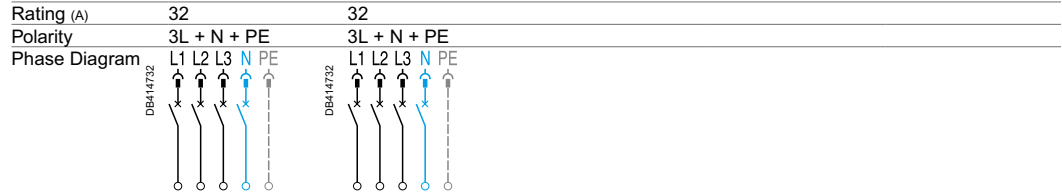

Cabling		
Protection Type (Not Supplied)	8 modules 18 mm	8 modules 18 mm
Body Material	Plastic	Plastic
Cable Output	2 sockets NF 10/16A	1 socket NF 10/16A + 1 Industrial socket 16A
Available Area (mm)	-	-
Connection	Patrika Power sockets	Patrika Power sockets
Maximum Rigid Cable Size (mm ²)	See Acti9 and Pratika catalogs	See Acti9 and Pratika catalogs
Maximum Flexible Cable Size (mm ²)	See Acti9 and Pratika catalogs	See Acti9 and Pratika catalogs
	Supplied with blanking plate	Supplied with blanking plate

Additional Characteristics		
IP	IP55	IP55
Color	White	White
Weight (kg)	1,9	1,9
Selling Unit	1	1
MOQ	1	1

⁽¹⁾ Not included

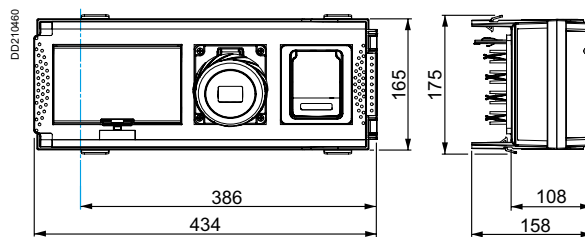

KSB32CP...

Classic offer

Connectors and Tap-off units

Disconnection by unplugging the connector

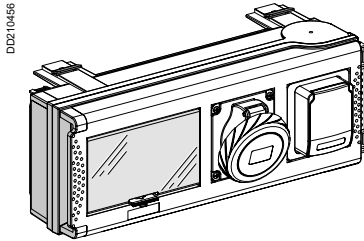

KSB32CP...

Delivered equipped with a DIN rail
For 18 mm modular devices ⁽¹⁾. With Household Schuko and Industrial sockets

Cat. n°	KSB32CP11D	KSB32CP15D	KSB32CP35
Compatible with	KSA100 to 1000	KSA100 to 1000	KSA100 to 1000

Rating (A)	32	32	32
Polarity	3L + N + PE	3L + N + PE	3L + N + PE
Phase Diagram			

Cabling			
Protection Type (Not Supplied)	8 modules 18 mm	8 modules 18 mm	8 modules 18 mm
Body Material	Plastic	Plastic	Plastic
Cable Output	2 sockets Schuko 10/16A	1 socket Schuko 10/16A + 1 Industrial 16A socket 16A	2 industrial sockets
Available Area (mm)	-	-	-
Connection	Patrika Power sockets	Patrika Power sockets	Patrika Power sockets
Maximum Rigid Cable Size (mm ²)	See Acti9 and Pratika catalogs	See Acti9 and Pratika catalogs	See Acti9 and Pratika catalogs
Maximum Flexible Cable Size (mm ²)	See Acti9 and Pratika catalogs	See Acti9 and Pratika catalogs	See Acti9 and Pratika catalogs
	Supplied with blanking plate	Supplied with blanking plate	Supplied with blanking plate

Additional Characteristics			
IP	IP55	IP55	IP55
Color	White	White	White
Weight (kg)	1,9	1,9	1,9
Selling Unit	1	1	1
MOQ	1	1	1

⁽¹⁾ Not included

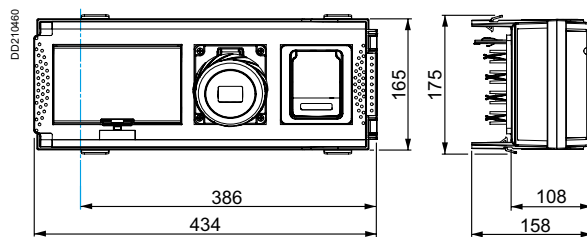

KSB32CP...



Classic offer

Connectors and Tap-off units

Disconnection by opening the door

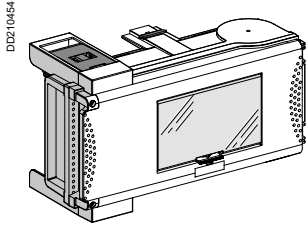

KSB63 SM •

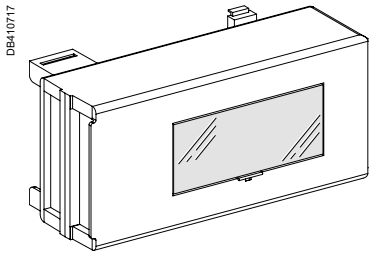

KSB100 SM •

Delivered equipped with a DIN rail
For 18 mm modular devices ⁽¹⁾

Cat. n°	KSB63SM48	KSB63SM58	KSB100SM412	KSB100SM512
Compatible with	KSA100 to 1000	KSA100 to 1000	KSA100 to 1000	KSA100 to 1000

Rating (A)	63	63	100	100
Polarity	3L + N + PE	3L + PEN	3L + N + PE	3L + PEN
Phase Diagram				

Cabling				
Protection Type (Not Supplied)	8 modules 18 mm	8 modules 18 mm	12 modules 18 mm	12 modules 18 mm

Body Material	Plastic	Plastic	Plastic	Plastic
Cable Output	Cable gland ⁽²⁾	Cable gland ⁽²⁾	Cable gland ⁽²⁾	Cable gland ⁽²⁾

Available Area (mm)	2 x ISO 50 for multipolar cable	2 x ISO 50 for multipolar cable	2 x ISO 63 for multipolar cable	2 x ISO 63 for multipolar cable
Connection	Silver-plated copper terminals (M6) for Copper compression lugs	Silver-plated copper terminals (M6) for Copper compression lugs	Silver-plated copper terminals (M6) for Copper compression lugs	Silver-plated copper terminals (M6) for Copper compression lugs
Maximum Rigid Cable Size (mm ²)	16	16	35	35
Maximum Flexible Cable Size (mm ²)	16	16	35	35

	Supplied with blanking plate	Supplied with blanking plate	Supplied with blanking plate	Supplied with blanking plate
--	------------------------------	------------------------------	------------------------------	------------------------------

⁽²⁾ Not included ⁽²⁾ Not included ⁽²⁾ Not included ⁽²⁾ Not included

Additional Characteristics				
IP	IP55	IP55	IP55	IP55
Color	White	White	White	White
Weight (kg)	1,8	2	2,8	2,5
Selling Unit	1	1	1	1
MOQ	1	1	1	1

Tap-off units not compatible with Circuit breaker NG125. See KSB160SM•13

⁽¹⁾ Not included

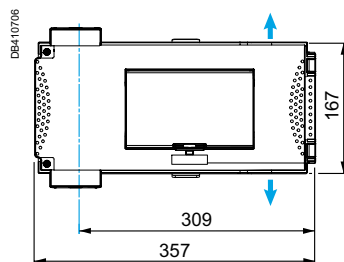

KSB63 SM •

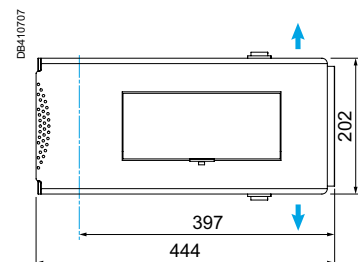
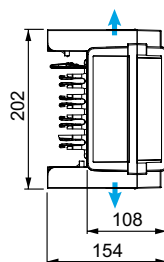

KSB100 SM •

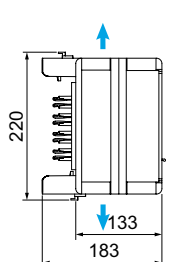

Classic offer

Connectors and Tap-off units

Disconnection by opening the door

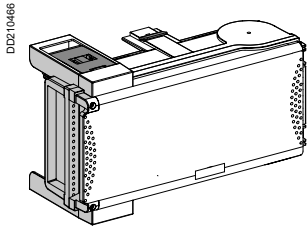

KSB32 SG •

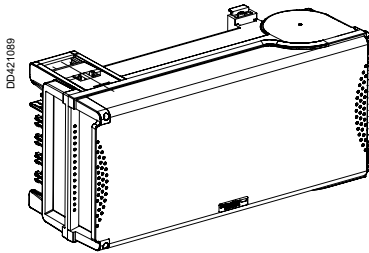

KSB80 SG •

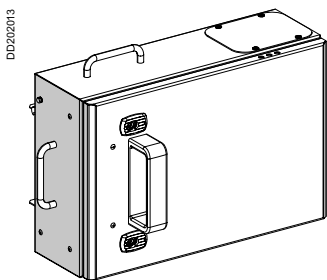

KSB160 SG •

Delivered equipped with a fuse holder
For BS fuses ⁽¹⁾

Cat. n°	KSB32SG4	KSB80SG4	KSB160SG4
Compatible with	KSA100 to 1000	KSA100 to 1000	KSA100 to 1000

Rating (A)	32	80	160
Polarity	3L + N + PE	3L + N + PE	3L + N + PE
Phase Diagram			

Cabling			
Protection Type (Not Supplied)	Fuses BS88 - A1	Fuses BS88 - A1 or A3	Fuses BS88 - B1 or B2

Body Material	Plastic	Plastic	Metal
Cable Output	Cable gland ⁽²⁾	Cable gland ⁽²⁾	2 lateral 1.5mm steel cable plates 245 x 115

Available Area (mm)	2 x ISO 50 for multipolar cable	Max ISO63 Multipolar- Max ISO20 Unipolar	2 x (215 x 185)
---------------------	---------------------------------	--	-----------------

Connection	Tin-plated copper clamps for copper wires	Copper terminals (M6) for Copper compression lugs	Terminals on the fuse holder
------------	---	---	------------------------------

Maximum Rigid Cable Size (mm ²)	25	50	50
Maximum Flexible Cable Size (mm ²)	25	50	50

⁽²⁾ Not included ⁽²⁾ Not included -

Additional Characteristics			
IP	IP55	IP55	IP55
Color	White	White	White
Weight (kg)	1,4	3,4	11
Selling Unit	1	1	1
MOQ	1	1	1

⁽¹⁾ Not included

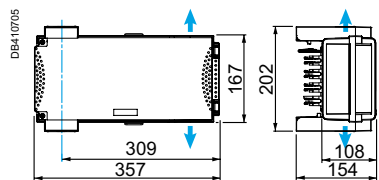

KSB32SG4

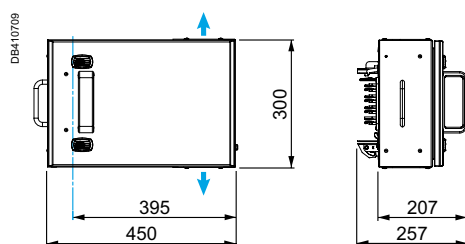

KSB160SG4

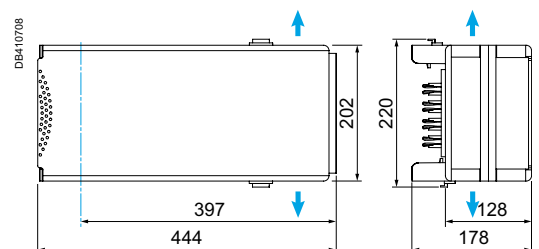

KSB80SG4



Classic offer

Connectors and Tap-off units

Disconnection by opening the door

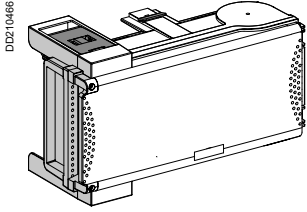

KSB50 SF •

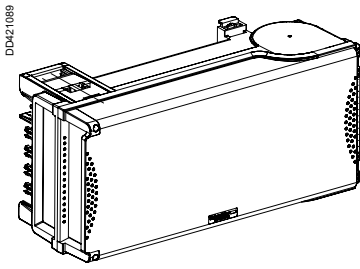

KSB100 SF •

Delivered equipped with a fuse holder
For NF fuses (Cylindrical) ⁽¹⁾

Cat. n°	KSB50SF4	KSB50SF5	KSB100SF4	KSB100SF5
Compatible with	KSA100 to 1000	KSA100 to 1000	KSA100 to 1000	KSA100 to 1000
Rating (A)	50	50	100	100
Polarity	3L + N + PE	3L + PEN	3L + N + PE	3L + PEN
Phase Diagram				
Cabling				
Protection Type (Not Supplied)	Fuses NF 14x51 - gG or aM	Fuses NF 14x51 - gG or aM	Fuses NF 22x58 - gG or aM	Fuses NF 22x58 - gG or aM
Body Material	Plastic	Plastic	Plastic	Plastic
Cable Output	Cable gland ⁽²⁾	Cable gland ⁽²⁾	Cable gland ⁽²⁾	Cable gland ⁽²⁾
Available Area (mm)	2 x ISO 50 for multipolar cable	2 x ISO 50 for multipolar cable	2 x ISO 63 for multipolar cable	2 x ISO 63 for multipolar cable
Connection	Silver-plated copper clamps for copper wires	Silver-plated copper clamps for copper wires	Silver-plated copper terminals (M6) for Copper compression lugs	Silver-plated copper terminals (M6) for Copper compression lugs
Maximum Rigid Cable Size (mm ²)	25	25	50	50
Maximum Flexible Cable Size (mm ²)	25	25	50	50
	⁽²⁾ Not included	⁽²⁾ Not included	⁽²⁾ Not included	⁽²⁾ Not included

Additional Characteristics

IP	IP55	IP55	IP55	IP55
Color	White	White	White	White
Weight (kg)	1,4	1,4	3,5	3,5
Selling Unit	1	1	1	1
MOQ	1	1	1	1

⁽¹⁾ Not included

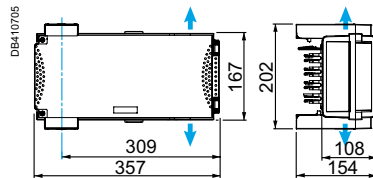

KSB50 SF •

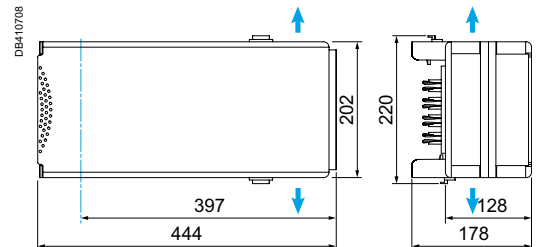

KSB100 SF •

Classic offer

Power sockets for CP tap-off units

Pratika power sockets



PG 149203.eps
PKY16F723

Designation	Rated current (A)	Rated voltage (V AC)	Number of poles	Dimensions (W x H in mm)	Cat. no.	Weight (kg)	
Industrial sockets Pratika	16	200-250	2P + T	65 x 85	PKY16F723	-	
			3P + N + T	90 x 100	PKY16F725	-	
	32 ⁽¹⁾	200-250	200-250	2P + T	65 x 85	PKY16F733	-
				3P + N + T	90 x 100	PKY16F735	-
			380-415	2P + T	90 x 100	PKY32F723	-
				3P + N + T	90 x 100	PKY32F725	-
Household NF sockets	10 to 16	250	2P + T	65 x 85	81140	-	
			3P + N + T	90 x 100	PKY32F735	-	
Household Schuko sockets	10 to 16	250	2P + T	65 x 85	81141	-	
Screw-on plate	For blanking of unused openings				13137	0.10	
	For adapting 65 x 85 mm power-socket bases				13136	0.09	

⁽¹⁾ The sum of currents in the 2 sockets installed on the tap-off unit \leq 32 A.

Classic offer

Connectors and Tap-off units

Disconnection by opening the door

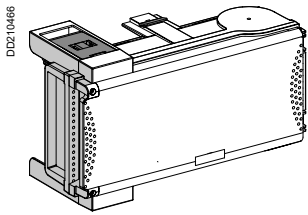

KSB SD SN •

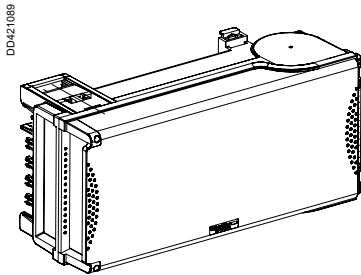

KSB63 SD •

Delivered equipped with a fuse holder
For NZ/DZ fuses ⁽¹⁾

Cat. n°	KSB25SD4	KSB50SN4	KSB63SD4
Compatible with	KSA100 to 1000	KSA100 to 1000	KSA100 to 1000

Rating (A)	25	50	63
Polarity	3L + N + PE	3L + N + PE	3L + N + PE
Phase Diagram			

Cabling			
Protection Type (Not Supplied)	Fuses DZ - E27	Fuses NZ - E18	Fuses DZ - E33

Body Material	Plastic	Plastic	Plastic
Cable Output	Cable gland ⁽²⁾	Cable gland ⁽²⁾	Cable gland ⁽²⁾

Available Area (mm)	2 x ISO 50 for multipolar cable	2 x ISO 50 for multipolar cable	2 x ISO 63 for multipolar cable
---------------------	---------------------------------	---------------------------------	---------------------------------

Connection	Terminals on the fuse holder	Terminals on the fuse holder	Terminals on the fuse holder
------------	------------------------------	------------------------------	------------------------------

Maximum Rigid Cable Size (mm ²)	25	25	25
---	----	----	----

Maximum Flexible Cable Size (mm ²)	25	25	25
--	----	----	----

⁽²⁾ Not included ⁽²⁾ Not included ⁽²⁾ Not included

Additional Characteristics			
IP	IP55	IP55	IP55
Color	White	White	White
Weight (kg)	1,4	1,4	2,6
Selling Unit	1	1	1
MOQ	1	1	1

⁽¹⁾ Not included

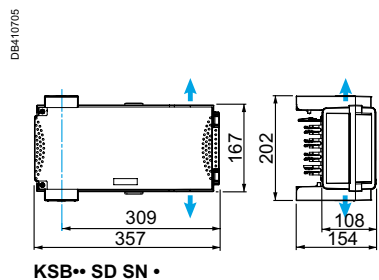

KSB SD SN •

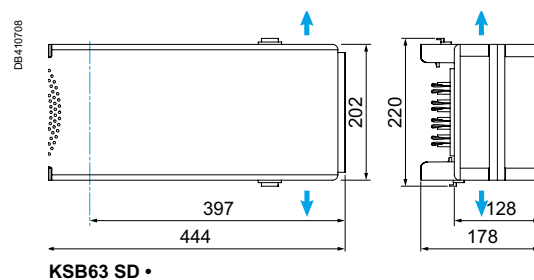

KSB63 SD •

Classic offer

Connectors and Tap-off units

Disconnection by opening the door

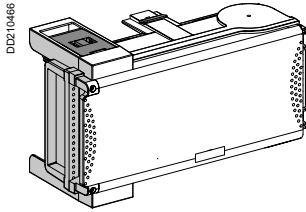

KSB SD SN •

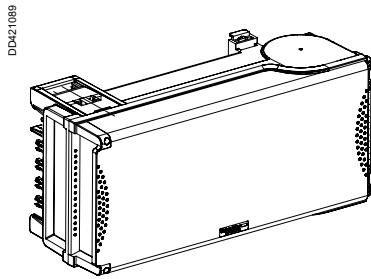

KSB63 SD •

Delivered equipped with a fuse holder
For NZ/DZ fuses ⁽¹⁾

Cat. n°	KSB25SD5	KSB50SN5	KSB63SD5
Compatible with	KSA100 to 1000	KSA100 to 1000	KSA100 to 1000

Rating (A)	25	50	63
Polarity	3L + PEN	3L + PEN	3L + PEN
Phase Diagram	<p>DDM14769</p>	<p>DDM14769</p>	<p>DDM14769</p>

Cabling			
Protection Type (Not Supplied)	Fuses DZ - E27	Fuses NZ - E18	Fuses DZ - E33

Body Material	Plastic	Plastic	Plastic
Cable Output	Cable gland ⁽²⁾	Cable gland ⁽²⁾	Cable gland ⁽²⁾

Available Area (mm)	2 x ISO 50 for multipolar cable	2 x ISO 50 for multipolar cable	2 x ISO 63 for multipolar cable
---------------------	---------------------------------	---------------------------------	---------------------------------

Connection	Terminals on the fuse holder	Terminals on the fuse holder	Terminals on the fuse holder
------------	------------------------------	------------------------------	------------------------------

Maximum Rigid Cable Size (mm ²)	25	25	25
---	----	----	----

Maximum Flexible Cable Size (mm ²)	25	25	25
--	----	----	----

⁽²⁾ Not included ⁽²⁾ Not included ⁽²⁾ Not included

Additional Characteristics			
IP	IP55	IP55	IP55
Color	White	White	White
Weight (kg)	1,4	1,4	2,6
Selling Unit	1	1	1
MOQ	1	1	1

⁽¹⁾ Not included

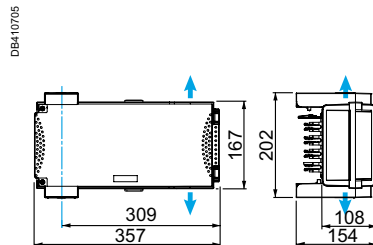

KSB SD SN •

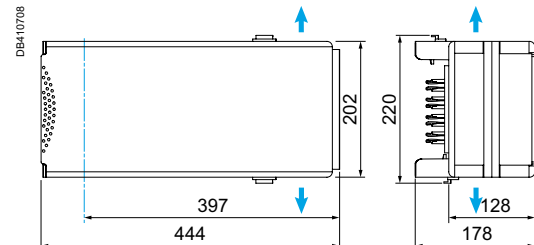

KSB63 SD •

D

Classic offer

Connectors and Tap-off units

Disconnection by opening the door

DD421089

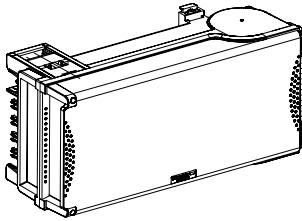

Delivered equipped with a fuse holder
For Blade-type fuses ⁽¹⁾

Cat. n°	KSB100SE4	KSB160SE4	KSB160SF4	KSB250SE4	KSB400SE4
Compatible with	KSA100 to 1000	KSA100 to 1000	KSA100 to 1000	KSA100 to 1000	KSA500 to 1000

DD202013

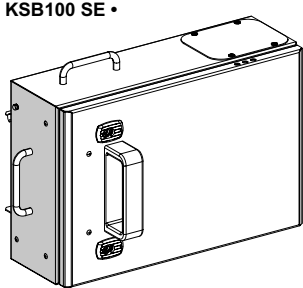

KSB100 SE •

Rating (A)	100	160	160	250	400
Polarity	3L + N + PE	3L + N + PE	3L + N + PE	3L + N + PE	3L + N + PE
Phase Diagram					

Cabling					
Protection Type (Not Supplied)	Fuses Size 00 - gG or aM	Fuses Size 00 - gG or aM	Fuses Size 0 - gG or aM	Fuses Size 1 - gG or aM	Fuses Size 2 - gG or aM

Body Material	Plastic	Metal	Metal	Metal	Metal
Cable Output	Cable gland ⁽²⁾	2 lateral 1.5 mm steel cable plates 245 x 115	2 lateral 1.5 mm steel cable plates 245 x 115	1 rear 1.5 mm steel cable plate 345 x 130	1 bottom 1.5 mm steel cable plate 545 x 130
Available Area (mm)	2 x ISO 63 for multipolar cable	2 x (215 x 185)	2 x (215 x 185)	315 x 100	515 x 100

Connection	Terminals on the fuse holder	Terminals on the fuse holder	Terminals on the fuse holder	Copper plate with 1 x Ø13mm for Copper compression lugs	Copper plate with 1 x Ø12mm for Copper compression lugs
------------	------------------------------	------------------------------	------------------------------	---	---

Maximum Rigid Cable Size (mm ²)	35	70	70	150	240
Maximum Flexible Cable Size (mm ²)	50	70	70	150	240

⁽²⁾ Not included

Additional Characteristics

IP	IP55	IP55	IP55	IP55	IP55
Color	White	White	White	White	White
Weight (kg)	3,5	9	8	19,8	29
Selling Unit	1	1	1	1	1
MOQ	1	1	1	1	1

⁽¹⁾ Not included

DB410718

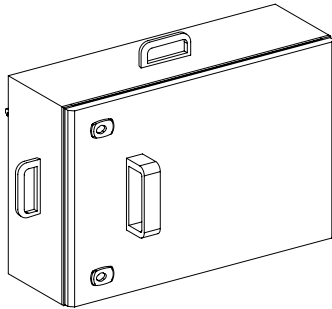

KSB160 SE • and SF •

DB410755

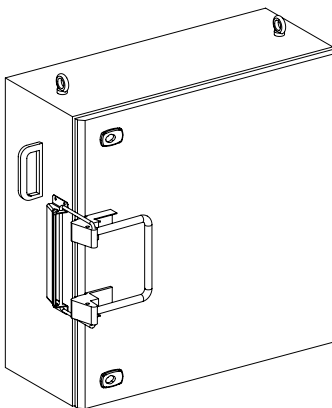

KSB250 SE •

KSB400 SE •

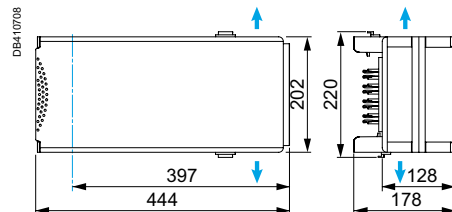

KSB100 SE •

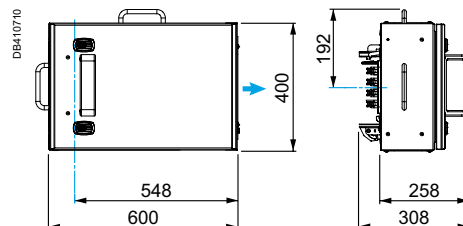

KSB250 SE •

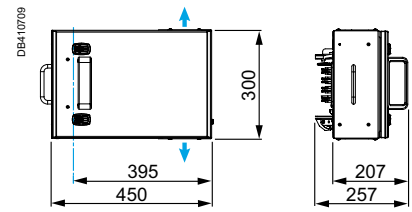

KSB160 SE • and KSB160 SF •

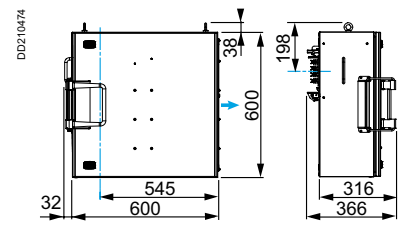

KSB400 SE •

Classic offer

Connectors and Tap-off units

Disconnection by opening the door

DD421089

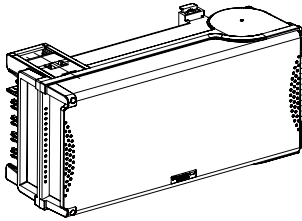

KSB100 SE •

DD202013

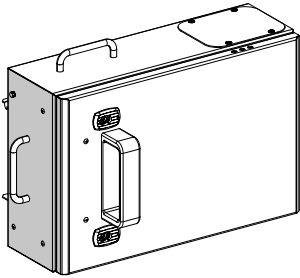

KSB160 SE • and SF •

DB410718

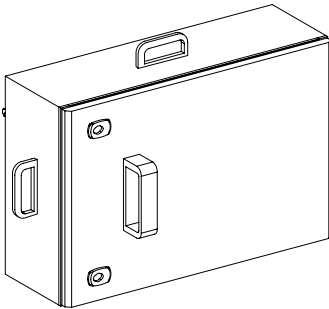

KSB250 SE •

DB410735

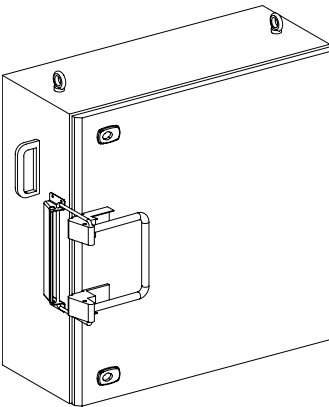

KSB400 SE •

**Delivered equipped with a fuse holder
For Blade-type fuses ⁽¹⁾**

Cat. n°	KSB100SE5	KSB160SE5	KSB160SF5	KSB250SE5	KSB400SE5
Compatible with	KSA100 to 1000	KSA100 to 1000	KSA100 to 1000	KSA100 to 1000	KSA500 to 1000

Rating (A)	100	160	160	250	400
Polarity	3L + PEN	3L + PEN	3L + PEN	3L + PEN	3L + PEN
Phase Diagram					

Cabling					
Protection Type (Not Supplied)	Fuses Size 00 - gG or aM	Fuses Size 00 - gG or aM	Fuses Size 0 - gG or aM	Fuses Size 1 - gG or aM	Fuses Size 2 - gG or aM

Body Material	Plastic	Metal	Metal	Metal	Metal
Cable Output	Cable gland ⁽²⁾	2 lateral 1.5 mm steel cable plates 245 x 115	2 lateral 1.5 mm steel cable plates 245 x 115	1 rear 1.5 mm steel cable plate 345 x 130	1 bottom 1.5 mm steel cable plate 545 x 130
Available Area (mm²)	2 x ISO 63 for multipolar cable	2 x (215 x 185)	2 x (215 x 185)	315 x 100	515 x 100

Connection	Terminals on the fuse holder	Terminals on the fuse holder	Terminals on the fuse holder	Copper plate with x Ø13mm for Copper compression lugs	Copper plate with 1 x Ø12mm for Copper compression lugs
Maximum Rigid Cable Size (mm²)	35	70	70	150	240
Maximum Flexible Cable Size (mm²)	50	70	70	150	240

⁽²⁾ Not included

Additional Characteristics					
IP	IP55	IP55	IP55	IP55	IP55
Color	White	White	White	White	White
Weight (kg)	3,5	8,8	8,9	18	30
Selling Unit	1	1	1	1	1
MOQ	1	1	1	1	1

⁽¹⁾ Not included

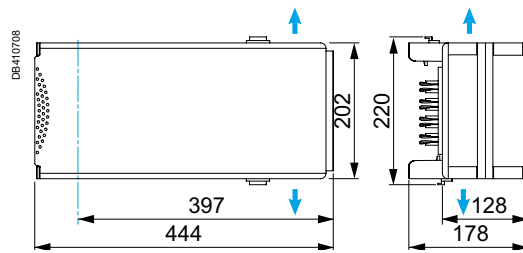

KSB100 SE •

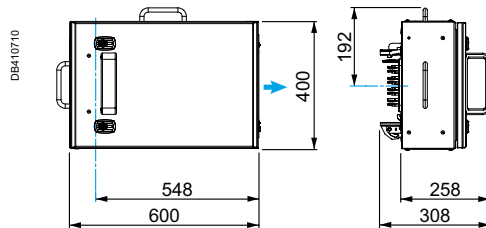

KSB250 SE •

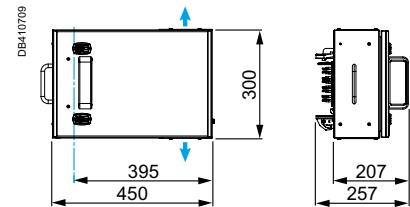

KSB160 SE • and SF •

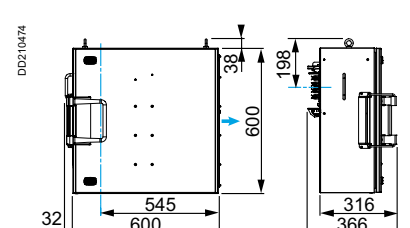

KSB400 SE •

D

Classic offer

Connectors and Tap-off units

Switching with an extended rotary handle located on the door

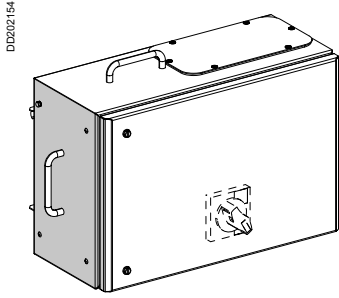

KSB160 SM •

**Delivered equipped with a mounting plate for 1 Circuit Breaker
For NG Circuit Breaker ⁽¹⁾**

Cat. n°	KSB160SM413	KSB160SM513
Compatible with	KSA100 to 1000	KSA100 to 1000

Rating (A)	160	160
Polarity	3L + N + PE	3L + PEN
Phase Diagram		

Cabling		
Protection Type (Not Supplied)	NG125 or NG160	NG125 or NG160

Body Material	Metal	Metal
Cable Output	2 lateral 1.5 mm steel cable plates 245 x 130	2 lateral 1.5 mm steel cable plates 245 x 130

Available Area (mm)	2 x (215 x 100)	2 x (215 x 100)
----------------------------	-----------------	-----------------

Connection	NG Terminals	NG Terminals
-------------------	--------------	--------------

Maximum Rigid Cable Size (mm²)	See NG catalog	See NG catalog
--	----------------	----------------

Maximum Flexible Cable Size (mm²)	See NG catalog	See NG catalog
---	----------------	----------------

NG125: Extended rotary handle 19088 NG125: Extended rotary handle 19088

NG160: Extended rotary handle 28060 NG160: Extended rotary handle 28060

Additional Characteristics		
IP	IP55	IP55
Color	White	White
Weight (kg)	9	9
Selling Unit	1	1
MOQ	1	1

⁽¹⁾ Not included

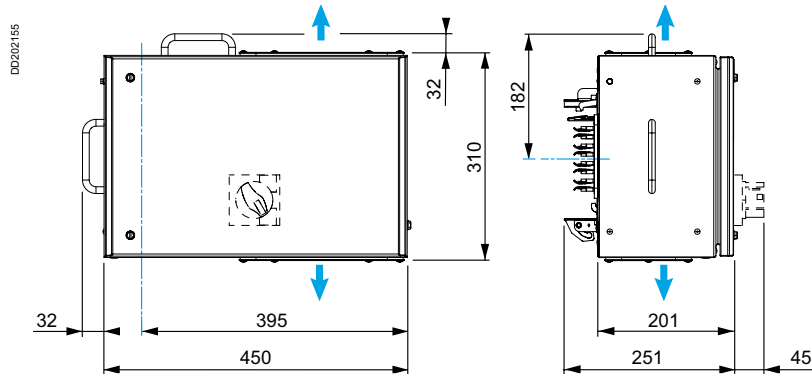

KSB160 SM •

Classic offer

Connectors and Tap-off units

Switching with an extended rotary handle located on the door

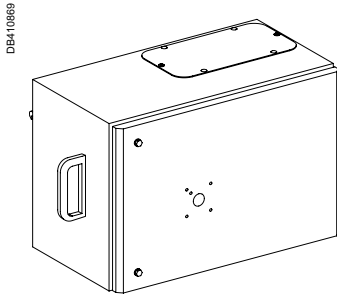

KSB160 DM 4

Delivered equipped with a mounting plate for 1 Circuit Breaker For NSXm Circuit Breaker ⁽¹⁾

Cat. n°	KSB160DM4	KSB160DM5
Compatible with	KSA100 to 1000	KSA100 to 1000

Rating (A)	160	160
Polarity	3L + N + PE	3L + PEN
Phase Diagram		

Cabling		
Protection Type (Not Supplied)	NSXm160 - N, H, L	NSXm160 - N, H, L

Body Material	Metal	Metal
Cable Output	2 lateral and 1 rear steel cable plates 245 x 130	2 lateral and 1 rear steel cable plates 245 x 130
Available Area (mm²)	3 x (215 x 100)	3 x (215 x 100)
Connection	On NSXm Terminals	On NSXm Terminals

Maximum Rigid Cable Size (mm²)	See NSXm catalog	See NSXm catalog
Maximum Flexible Cable Size (mm²)	See NSXm catalog	See NSXm catalog

NSXm160: Extended rotary handle
LV426933 (IP54)

NSXm160: Extended rotary handle
LV426933 (IP54)

NSXm160: Extended rotary handle
LV426934 (IP65)

NSXm160: Extended rotary handle
LV426934 (IP65)

Additional Characteristics		
IP	IP55	IP55
Color	White	White
Weight (kg)	9,5	9
Selling Unit	1	1
MOQ	1	1

⁽¹⁾ Not included

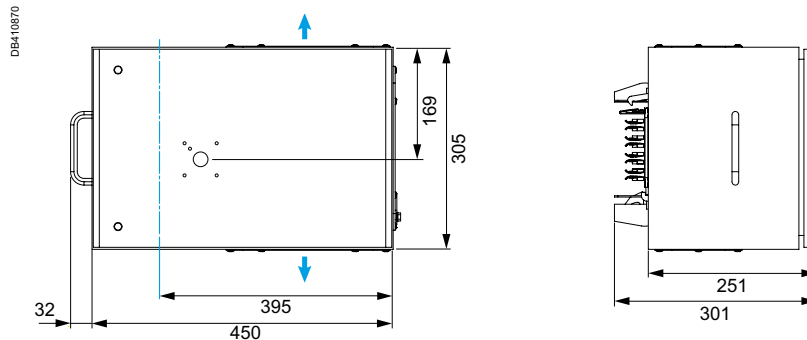

KSB160 DM 4



Classic offer

Connectors and Tap-off units

Switching with an extended rotary handle located on the door

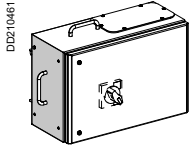

KSB160 DC 4

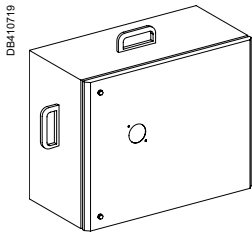

KSB250 DC 4

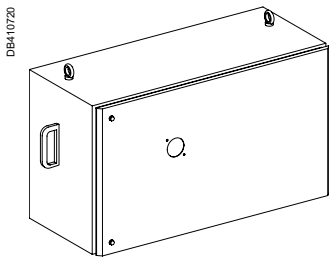

KSB400 DC 4

**Delivered equipped with a mounting plate for 1 Circuit Breaker
For NSX Circuit Breaker 4P ⁽¹⁾**

Cat. n°	KSB160DC4	KSB250DC4	KSB400DC4
Compatible with	KSA100 to 1000	KSA100 to 1000	KSA500 to 1000

Rating (A)	160	250	400
Polarity	3L + N + PE	3L + N + PE	3L + N + PE
Phase Diagram			

Cabling			
Protection Type (Not Supplied)	NSX100/NSX160 - N, H, L	NSX250 - N, H, L	NSX400 - N, H, L

Body Material	Metal	Metal	Metal
Cable Output	2 lateral 1.5 mm steel cable plates 245 x 130	2 lateral 1.5 mm steel cable plates 245 x 130	1 rear 1.5 mm steel cable plate 345 x 130
Available Area (mm)	2 x (215 x 100)	2 x (215 x 100)	315 x 100

Connection	On NSX Terminals	On NSX Terminals	On NSX Terminals
------------	------------------	------------------	------------------

Maximum Rigid Cable Size (mm ²)	See NSX catalog	See NSX catalog	See NSX catalog
Maximum Flexible Cable Size (mm ²)	See NSX catalog	See NSX catalog	See NSX catalog

NSX100/160: Extended rotary handle LV429338	NSX250: Extended rotary handle LV429338	NSX400: Extended rotary handle LV432598
--	---	---

Additional Characteristics			
IP	IP55	IP55	IP55
Color	White	White	White
Weight (kg)	9,5	12,5	19
Selling Unit	1	1	1
MOQ	1	1	1

⁽¹⁾ Not included

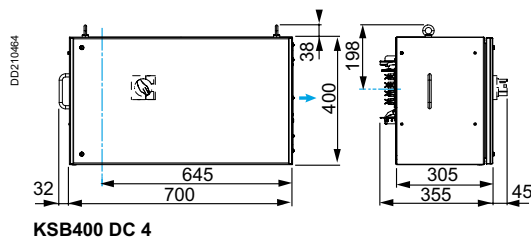
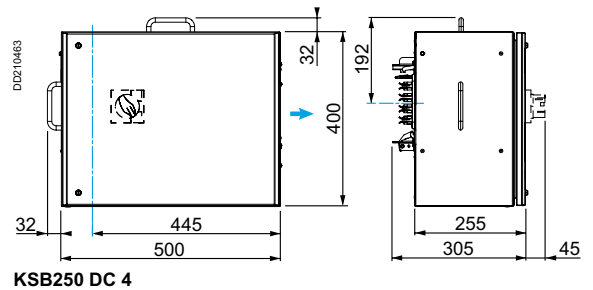
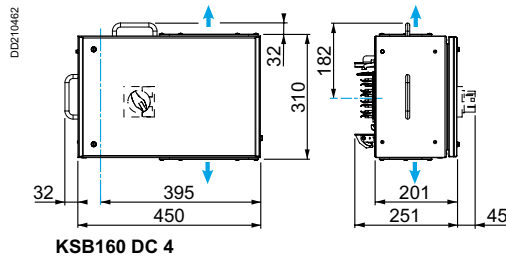

Classic offer

Connectors and Tap-off units

Switching with an extended rotary handle located on the door

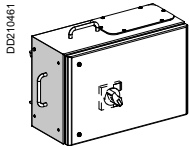

KSB160 DC 5

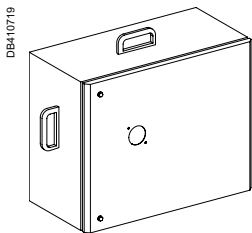

KSB250 DC 5

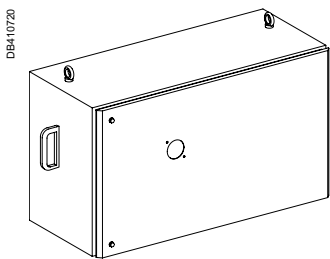

KSB400 DC 5

**Delivered equipped with a mounting plate for 1 Circuit Breaker
For NSX Circuit Breaker 3P ⁽¹⁾**

Cat. n°	KSB160DC5	KSB250DC5	KSB400DC5
Compatible with	KSA100 to 1000	KSA100 to 1000	KSA500 to 1000

Rating (A)	160	250	400
Polarity	3L + PEN	3L + PEN	3L + PEN
Phase Diagram			

Cabling			
Protection Type (Not Supplied)	NSX100/NSX160 - N, H, L	NSX250 - N, H, L	NSX400 - N, H, L

Body Material	Metal	Metal	Metal
Cable Output	2 lateral 1.5 mm steel cable plates 245 x 130	2 lateral 1.5 mm steel cable plates 245 x 130	1 rear 1.5 mm steel cable plate 345 x 130
Available Area (mm)	2 x (215 x 100)	2 x (215 x 100)	315 x 100
Connection	On NSX Terminals	On NSX Terminals	On NSX Terminals

Maximum Rigid Cable Size (mm ²)	See NSX catalog	See NSX catalog	See NSX catalog
Maximum Flexible Cable Size (mm ²)	See NSX catalog	See NSX catalog	See NSX catalog

NSX100/160: Extended rotary handle LV429338	NSX250: Extended rotary handle LV429338	NSX400: Extended rotary handle LV432598
--	---	---

Additional Characteristics			
IP	IP55	IP55	IP55
Color	White	White	White
Weight (kg)	9	20	20
Selling Unit	1	1	1
MOQ	1	1	1

⁽¹⁾ Not included

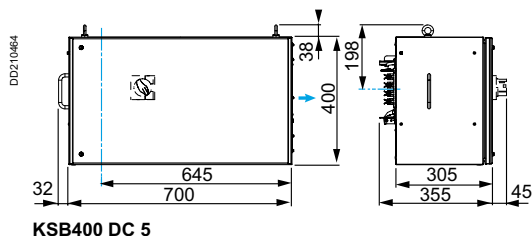
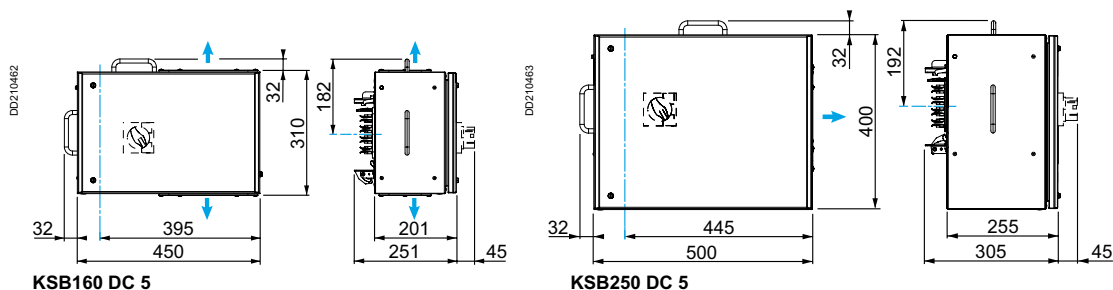

Classic offer

Accessories

For current KS offer

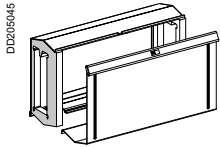

KSB400ZB2

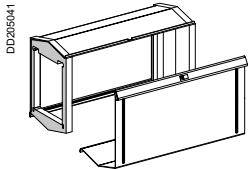

KSB1000ZB2

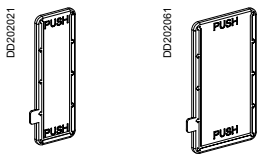

KSB400ZB1

KSB1000ZB1

IP kits

IP55 blanking plates for outlets and Sprinkler proofing kits

Cat. n°	KSB400ZB2	KSB1000ZB2	KSB400ZB1	KSB1000ZB1
Compatible with	KSA100 to 400	KSA500 to 1000	KSA100 to 400	KSA500 to 1000
Rating (A)	400	1000	400	1000
Polarity	-	-	-	-

Additional Characteristics

	KSB400ZB2	KSB1000ZB2	KSB400ZB1	KSB1000ZB1
IP	IP55	IP55	IP55	IP55
Color	White	White	White	White
Weight (kg)	1,3	2,05	0,01	0,01
Selling Unit	1	1	1	1
MOQ	1	1	10	10

For current KS offer

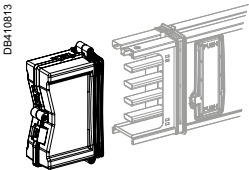

KSA400AF1

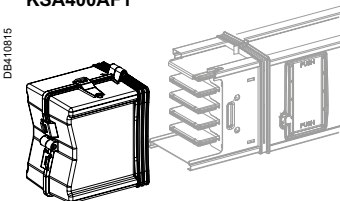

KSA1000AF1

Accessories

End covers and sealing kits

Cat. n°	KSA400AF1	KSA1000AF1	KSB1000ZP1	KSB1000ZP2
Compatible with	KSA100 to 400	KSA500 to 1000	KSA100 to 1000	KSA100 to 1000
Rating (A)	400	1000	0	0
Polarity	-	-	-	-

Characteristics

End feed unit for KS100 to KS400	End feed unit for KS500 to KS1000	To seal any screws	To seal KS outlets
----------------------------------	-----------------------------------	--------------------	--------------------

Additional Characteristics

	KSA400AF1	KSA1000AF1	KSB1000ZP1	KSB1000ZP2
IP	IP55	IP55	IP55	IP55
Color	White	White	White	White
Weight (kg)	0,2	0,4	0,007	0,002
Selling Unit	1	1	1	1
MOQ	1	1	20	20

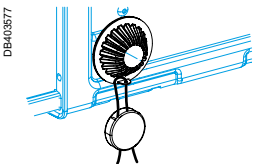

KSB1000ZP1

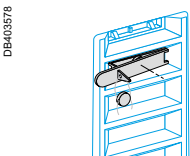

KSB1000ZP2

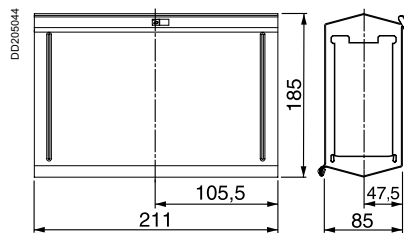

KSA400AF1

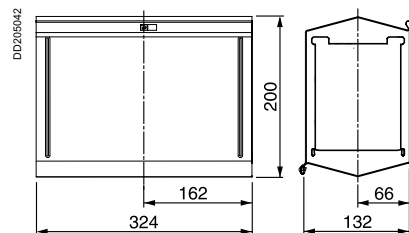

KSA1000AF1

KSB1000ZB2

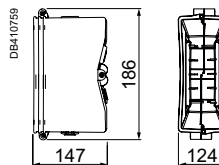
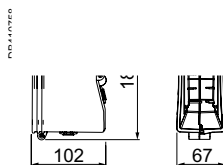

Classic offer

Accessories

For current KS offer

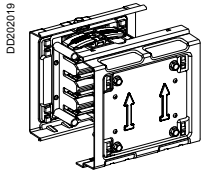

KSA250ZJ4

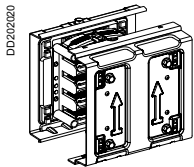

KSA400ZJ4

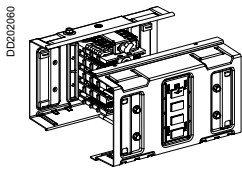

KSA630 and 1000 ZJ •

Spare parts Electrical and mechanical jointing unit

Cat. n°	KSA250ZJ4	KSA400ZJ4	KSA630ZJ4	KSA1000ZJ4
Compatible with	KSA100 to 250	KSA400	KSA500 to 1000	KSA500 to 1000
Rating (A)	250	400	630	1000
Polarity	3L + N + PE	3L + N + PE	3L + N + PE	3L + N + PE

Additional Characteristics

	KSA250ZJ4	KSA400ZJ4	KSA630ZJ4	KSA1000ZJ4
IP	IP55	IP55	IP55	IP55
Color	White	White	White	White
Weight (kg)	1,7	1,9	4,3	4,7
Selling Unit	1	1	1	1
MOQ	1	1	1	1

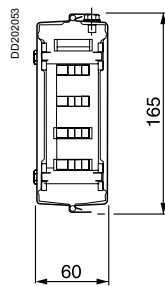

KSA250ZJ4

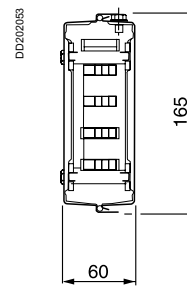
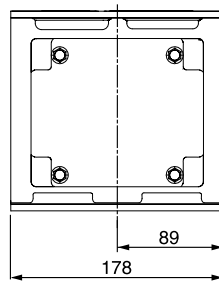

KSA400ZJ4

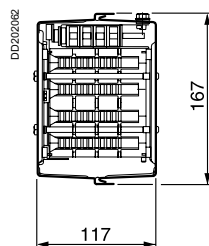
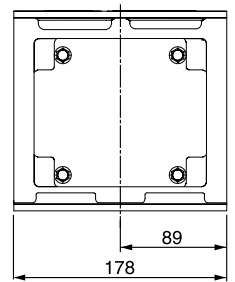

KSA630 and 1000 ZJ •

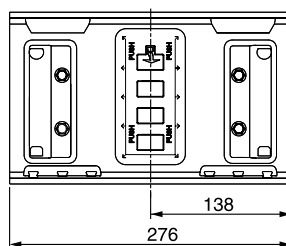

Canalis KS range

Advanced offer

All you need for a complex run adapted to your specificity

Description.....	page 69
Overview	page 78
Commercial numbers and dimensions.....	page 80

Description

Feed units and end covers

From 100 to 1000 A

Used to feed a KS line by cables or directly from the busbars in a switchboard. They can be mounted at the end of a line (end feed, left or right). Feed units with circuit breaker protection (not supplied) are available for all ratings.

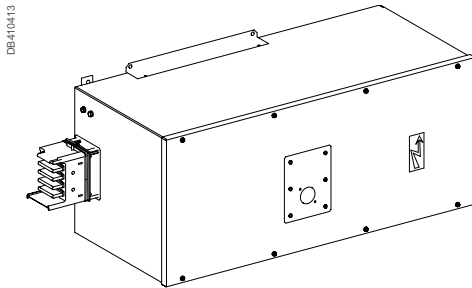

Equipped end feed unit for horizontal trunking Type AB.D

Two type of end feed units are available:

- left: ABGD,
- right: ABDD.

It can be equipped with a Compact NSX or NS circuit breaker and Micrologic. Control units are designed to protect power circuits and loads. Measurements of current, voltage, frequency, power and power quality optimize continuity of service and energy management. It is supplied with an end cover.

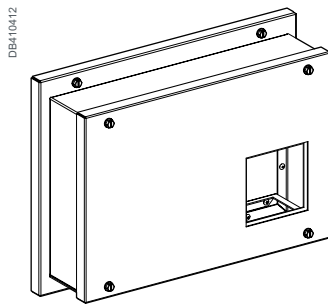

Communication box Type ABCB

Energy measurement is performed by an energy meter, visible on the front of the feed unit.

The measuring system consists of current transformers and a PM5350 for the monitoring of electrical consumption of busbar trunking lines. Communication with supervision systems is done by modbus TCP through a EGX300 gateway (PM5350 and EGX300 are not included).

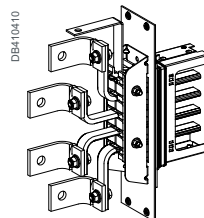

Flange feed unit Type AE

Equipped with splayed bars and a mounting plate for direct connection to the busbars of a switchboard. It can be mounted on either end of a component and is supplied with an end cover.

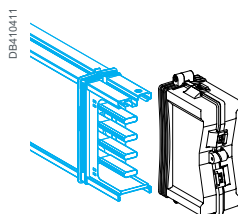

End cover Type AF

The end cover protects and isolates the ends of the conductors. It is mounted on the last component. Supplied with all feed units.

Description

Straight lengths with tap-off outlets

From 100 to 1000 A

Straight lengths components are designed to carry the current and supply loads.

Components of the Advanced offer are available in 6 ratings: 250, 400, 500, 630, 800 and 1000 A. Polarity can be 3L+N+PE or 3L+PE. Busbar trunking rated 100 to 400 A may be equipped with tap-off units up to 250 A. Higher rating busbar trunking elements may be equipped with the entire range of tap-off units.

All the insulating and plastic materials are halogen-free and have enhanced fire-withstand capabilities (incandescent wire test as per standard IEC 60695-2: 960 °C for components in contact with live parts and 650 °C for other components). The degree of protection of the busbar trunking is IP55 for indoor installations. For the sprinkler protection, it is necessary to add a specific sealing kit.

The basic structure of the line is made up of:

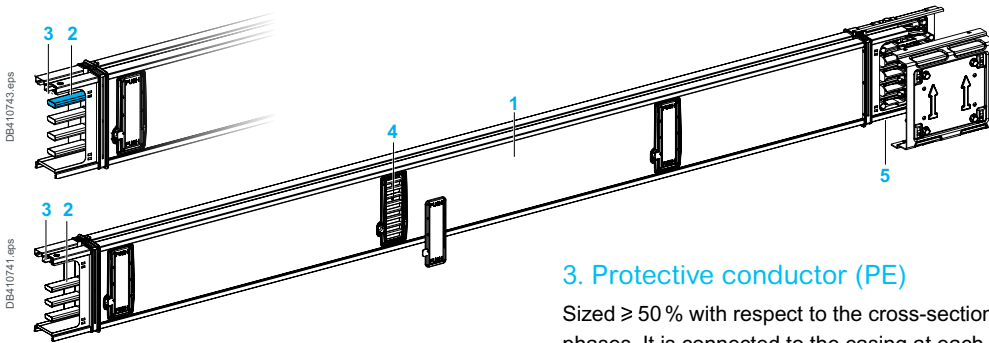

1. Casing, crimp closed, made of hot-galvanised sheet steel

Pre-lacquered RAL 9001 white, this casing, shaped and ribbed by roll-forming, provides excellent resistance to bending and twisting.

2. Conductors

For the 250 to 1000 A rating: aluminium bars equipped with silver-plated aluminium/copper bimetal laminate contacts electrically welded at junctions and tap-off points.

3. Protective conductor (PE)

Sized $\geq 50\%$ with respect to the cross-section of phases. It is connected to the casing at each junction

4. Tap-off outlets

From 0.5 to 1 meter on both sides of the trunking.

5. Mechanical and electrical jointing system

Electrical jointing is provided by a block with flexible grip contacts made of silver-plated copper.

This block equally absorbs the difference in conductor and casing thermal expansion for each length.

For the 400 to 1000 A rating, electrical jointing is ensured by a quarter-turn locking mechanism for each conductor.

The straight lengths without tap-off outlet are available in different lengths:

- in standard with 2 lengths: 2 and 3 metres
- made-to-measure.

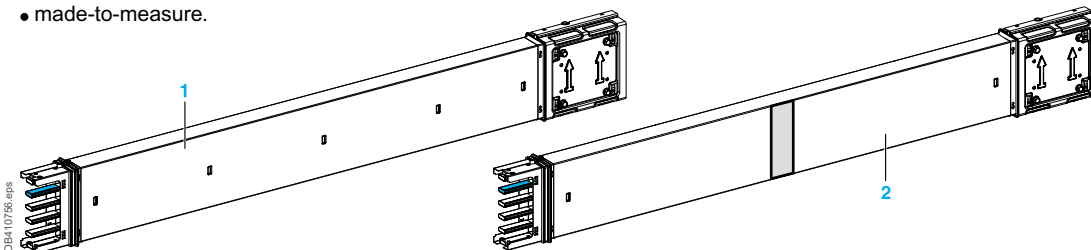

1. Custom-length run components

- Used to adjust the length of a line (e.g. between two changes in direction).
- These components are made to order and do not have tap-off outlets.

2. Fire barrier

- This type of length is used to transit a fire-resistant wall (e.g. between two rooms in a building).
- It has been tested in a certified laboratory and complies with standard EN 1363-1.

The laboratory report lists the following results:

- thermal insulation: ≥ 120 minutes
- resistance to flames: ≥ 120
- minutes stability: ≥ 120 minutes.

Description

Changing direction

From 100 to 1000 A

All components for changing direction of the Advanced offer are made to measure. They are available in several configurations:

Components with 2 sides	Type
Side (A) is fixed, side (B) is made to measure	41
Side (B) is fixed, side (A) is made to measure	42
Side (A) and (B) are made to measure	43

Components with 3 branches	Type
Side (A) and (C) are fixed, side (B) is made to measure	41
Side (A), (B) and (C) are made to measure	43

They are all supplied with a junction block. The degree of protection of the busbar trunking is IP55 for indoor installations.

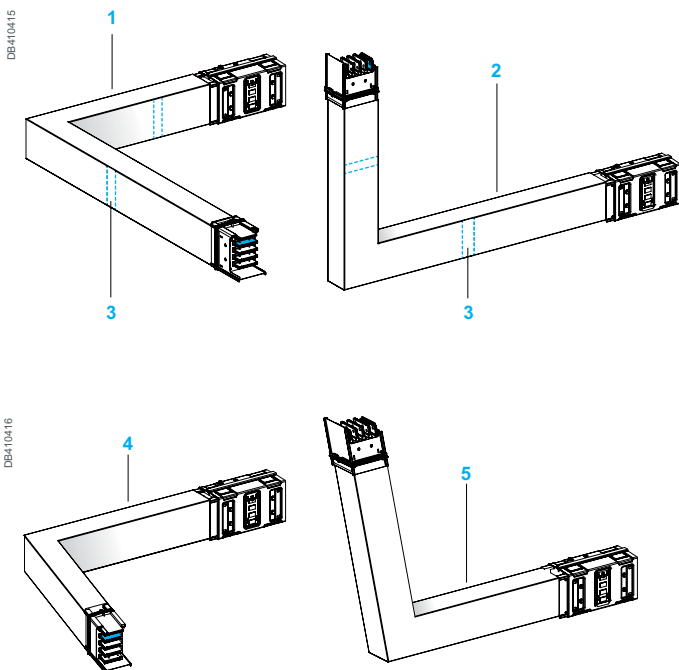

Elbows

Made-to-measure
Type DLR, DLL, DLE, DLF, DLC

Simple

1. Edgewise: two models. One for turning right and one for turning left.
2. Flatwise: two models, one for turning up and the other for turning down.

With fire barrier

3. Changes of direction fitted with fire breaks, located at the level of the slab or the partition, avoids any risk of fire spreading via the busbar trunking.

Edgewise: one model for turning right and one model for turning left.

Flatwise: two models, one for turning up and the other for turning down.

Elements can be fitted with **only one** fire barrier either on side A or B. Indicate the position of the fire barrier with dimensions X and Y.

Made-to-measure angle

3. Edgewise: one model for turning right or left.
4. Flatwise: two models, one for turning up and the other for turning down.

These element **can't be fitted** with a fire break.

Zeds

The Z-connections allow the busway to be installed around obstacles.

Made-to-measure
Type DZE, DZCG, DZCH

Simples

1. Edgewise: two models for turning down. One for turning right and the other for turning left.
2. Flatwise: two models for turning up. One for turning right and the other for turning left.

With fire barrier

3. Zeds can be fitted with fire breaks, located at the level of the slab or the partition, avoids any risk of fire spreading via the busbar trunking.

Elements can be fitted with **only one** fire barrier either on side A, B or C. Indicate the position of the fire barrier with dimensions X and Y.

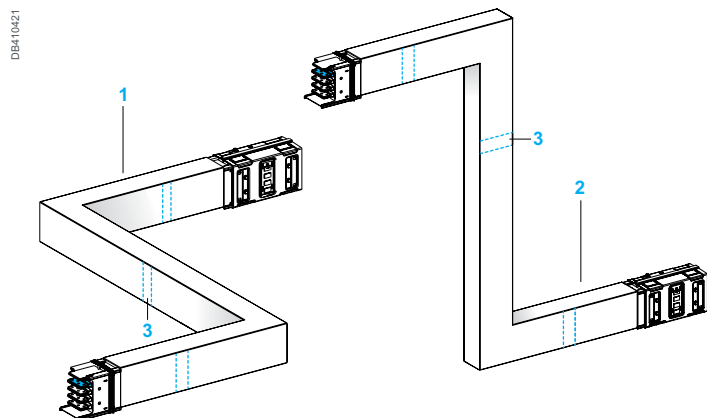

Description

Changing direction

From 100 to 1000 A

Multiples

Type **DMBL, DMCL, DMBK, DMCK**

Simple

1. Edgewise: two models for turning down.
One for turning right and the other for turning left.
2. Flatwise: two models for turning up.
One for turning right and the other for turning left.

With fire barrier

3. Multiples can be fitted with fire breaks, located at the level of the slab or the partition, avoids any risk of fire spreading via the busbar trunking.
Edgewise: two models for turning down.
One for turning right and the other for turning left.
Flatwise: two models for turning up.
One for turning right and the other for turning left.

Elements can be fitted with **only one** fire barrier either on side A, B or C. Indicate the position of the fire barrier with the dimension X and Y.

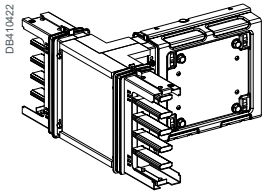
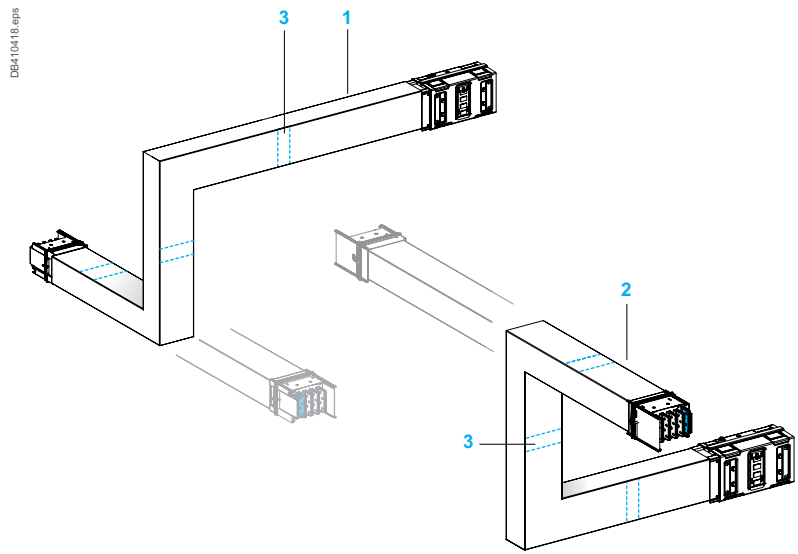

Tee

Type **DTC**

It enables to create 2 branches perpendicular to the main line.

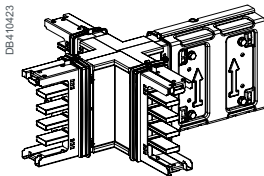

Cross

Type **DXC**

It enables to create 3 branches perpendicular to the main line.

Rating (A)	Dimensions (mm)			
	Height	Width (busbar trunking)	Width (jointing unit)	Length
100 to 400		54	63	1500
				2000
				3000
				5000
500 to 1000		113	119	1500
				2000
				3000
				5000

Description

Tap-off units

From 100 to 1000 A

For rapid connection of loads or secondary lines, in compliance with installation standards IEC 60364 and regulations, whatever the system earthing arrangement (TT, TNS, TNC or IT). They can be handled and removed under off-load conditions with the trunking energised. Tap-off units can be assembled on either side when the busbar trunking is installed edgewise. The tap-off outlets are automatically opened or closed when tap-off units are connected or removed. With the cover open, no live parts are accessible. It can also be installed on flatwise busbar trunking facing downwards.

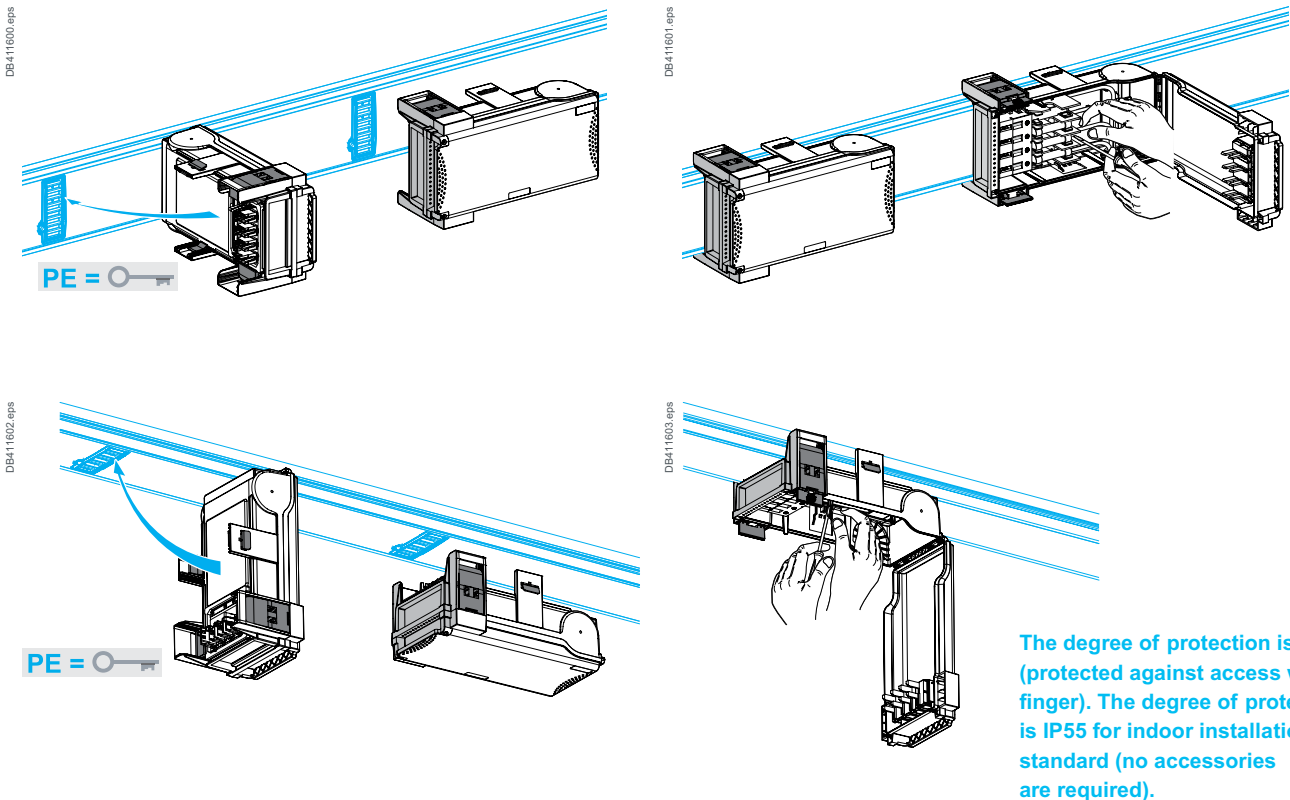

The degree of protection is IP••B (protected against access with a finger). The degree of protection is IP55 for indoor installations as standard (no accessories are required).

Disconnection principle

Disconnection by unplugging the tap-off unit.

The access to the electrical devices and the terminals is possible only when the tap-off unit is unplugged (i.e. not energised). An interlocking device restricts connection to the trunking when the cover has been removed.

Disconnection of tap-off units with fuses and modular devices (category AC22 to AC20) is obtained by opening the tap-unit cover.

Tap-off unit disconnection by unplugging the tap-off unit or opening the cover should be carried out only if the downstream load is de-energised.

For tap-units with circuit breakers, **restricts:**

- plugging and unplugging in the tap-off unit when the cover is closed
- closing the cover before the tap-off unit is locked onto the trunking
- having access to the electrical equipment and the terminals when energised
- opening the cover in the position "ON" (tap-off units equipped with a Compact NSX or NG circuit breaker).

These tap-off units can be equipped with certain accessories such as circuit-opening contacts on the cover, lead seals, etc.

Description

Tap-off units

From 100 to 1000 A

2 types of housing

1. Empty tap-off units with isolators (A) up to 100 A are made of plastic

- Colour: RAL 9001 white for the casing and the grip zones and transparent green for the cover. The fixing mechanisms are in RAL 7016.
- Material: self-extinguishing, halogen free insulating plastic (fire resistant and very high temperature withstand).
- Other characteristics: cable gland drilling zone, stainless steel screws and the door can be lead sealed.
- SV tap-off units are delivered empty for customisation.

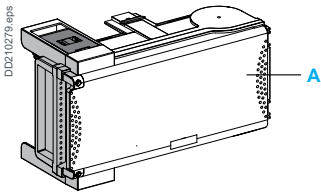

2. Tap-off units from 160 to 400 A are made of metal sheet (B)

- Colour: RAL 9001 white for the casing, RAL 9005 black for the grip zones (100 % polyester paint on galvanised sheet steel).
- 400 A tap-off units can be only installed on straight lengths ≥ 500 A.
- Other characteristics:
 - removable cover with hinges enabling opening up to 120°, vertically bevelled cover with double bends for enhanced rigidity, polyurethane gaskets
 - equipped with cable-gland plates marked every 25 mm and designed for maximum access.

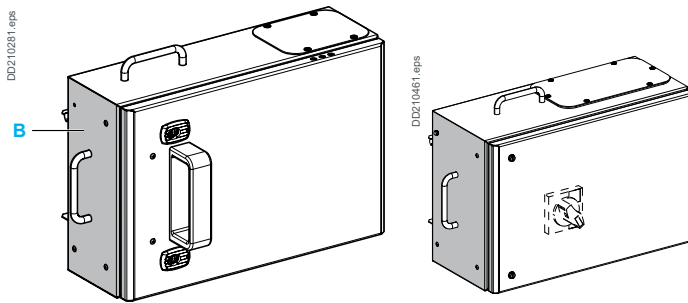

Description of the Advanced offer

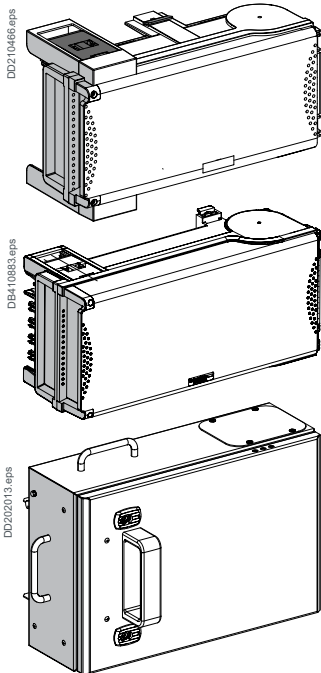

Empty tap-off units with isolator Type SV

SV tap-off units exist in 3 ratings: 50, 100 and 160 A, polarity 3L+N+PE or 3L+PEN.

They are delivered equipped with an isolator. Protection devices and other components can be installed in the tap-off units.

A mounted plate or a DIN rail (not included) must be installed to receive components.

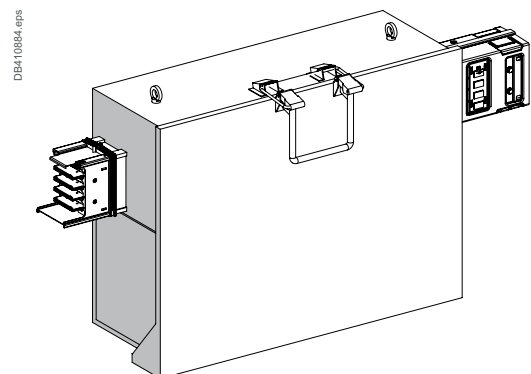

Tap-off units for fuses Type SE

SE 630A tap-off units exist in 2 polarities: 3L+N+PE or 3L+PEN.

They are equipped with fuse holders for size 3 fuses, blade type.

These tap-off units are not plug-in but mounted between 2 components and must be supported specifically. A jointing unit is delivered with each Schneider Electric tap-off units.

Description

Tap-off units

From 100 to 1000 A

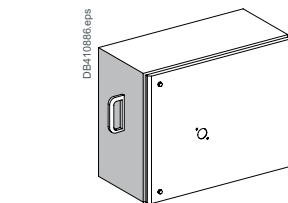
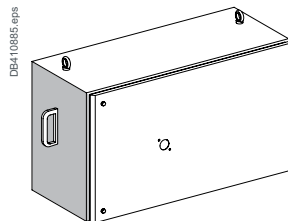

Tap-off units for fuse switch-disconnector Fupact INF Type SDF

SDF tap-off units exist in 2 ratings:

250 and 400 A and in 2 polarities 3L+N+PE or 3L+PEN.

They are equipped with a mounting plate designed to receive a INFB or INFD Fupact.

(See Fupact catalogue for commercial references).

An extended rotary handle is needed to switch the Fupact INF (Not included).

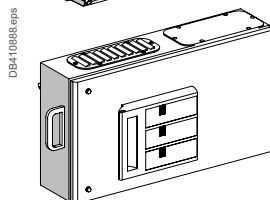
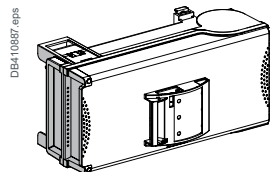

Tap-off units with a fuse switch-disconnector Fupact ISFT Type HD

HD tap-off units exist in ratings 125, 250 and 400 A in polarity 3L+PEN.

They are equipped with an isolator and with a fuse switch-disconnector for NH fuses located on the door.

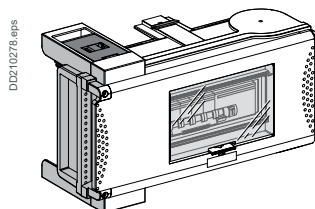

Tap-off unit with a Surge Arrester Type QPRD

These tap-off unit is equipped with an isolator and pre-equipped with a modular surge arrester Quick PRD40r.

These units are ready for use, can be plugged directly into the busbar trunking and no additional wiring required.

They should be positioned at least 30 m upstream of each load to be protected.

Description

Tap-off units

From 100 to 1000 A

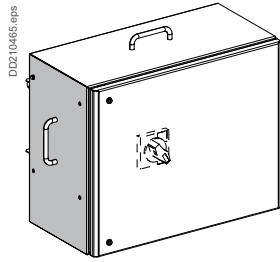

Tap-off units for Compact NSX circuit breaker and space provider for Current transformer (CT) blocks

Type DC.TRE

DC.TRE tap-off units exist in ratings 250 and 400 A and in 2 polarities: 3L+N+PE or 3L+PEN.

They are similar to DC tap-off units with a mounting plate for Compact NSX circuit breaker and for an extended rotary handle but larger for the installation of CT (current transformer) blocks.

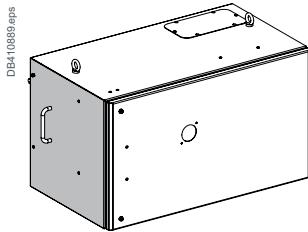

Tap-off units for Compact NSX circuit breaker PLUG-IN

Type DD

DD tap-off units exist in ratings 160 and 400 A in polarity 3L+N+PE.

They are equipped with a plug-in base for Compact NSX circuit breaker and for an extended rotary.

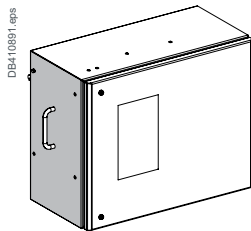
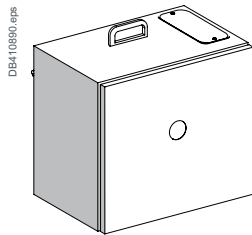

Tap-off units for Compact NSX circuit breaker with Electrical Handle

Type DB

DB tap-off units exist in ratings 160, 250 and 400 A in 2 polarities: 3L+N+PE or 3L+PEN.

They are equipped with a mounting plate for NSX circuit breaker equipped with an electrical handle. A door switch is also delivered to wire the electrical handle in order to restrict the opening of the door under load conditions.

Description

Compatibility of tap-off units and busbar trunkings

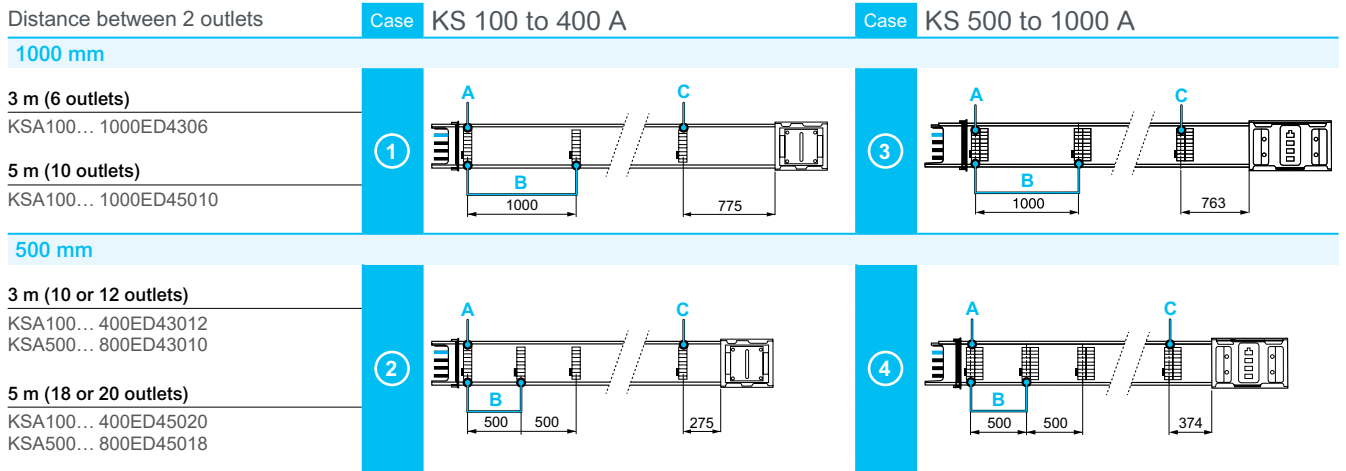

	Case	KS 100 to 400 A - Mountings available on:			Case	KS 500 to 1000 A - Mountings available on:		
		A 1st outlet	B 2 consecutive outlets	C Last outlet		A 1st outlet	B 2 consecutive outlets	C Last outlet
 W* = 157 mm	①	●	■	●	③	●	■	●
	②	●	■	X	④	●	■	●
 W = 444 mm	①	●	■	●	③	●	■	●
	②	●	■	X	④	●	■	X
 W = 450 mm	①	X	■	●	③	●	■	●
	②	X	■	X	④	●	■	X
 W = 500 mm	①	X	■	●	③	●	■	●
	②	X	△	X	④	●	△	X
 W = 600 mm	①	●	■	●	③	●	■	●
	②	●	△	X	④	●	△	X
 W = 700 mm	①	Impossible to fit a 400 A tap-off unit on a busway 100 to 400 A			③	●	■	X
	②	Impossible to fit a 400 A tap-off unit on a busway 100 to 400 A			④	●	△	X

* W = width of the tap-off unit

- The tap-off unit can be mounted at this position
- The right outlet is available for another tap-off unit
- △ The right outlet is hidden by the tap-off unit
- X Impossible to mount this tap-off unit at this position

E

Offer overview

Busbar ratings (A)

	100	160	250	400	500	630	800	1000	
Feed units									
Mounted on the busway									
For line protection with a NSX (not included)									
Right mounting	3L+N+PE	KSA250ABDD4	KSA250ABDD4	KSA250ABDD4	KSA400ABDD4	KSA630ABDD4	KSA630ABDD4	KSA1000ABDD4	KSA1000ABDD4
	3L+PEN	KSA250ABDD5	KSA250ABDD5	KSA250ABDD5	KSA400ABDD5	KSA630ABDD5	KSA630ABDD5	KSA1000ABDD5	KSA1000ABDD5
Left mounting	3L+N+PE	KSA250ABGD4	KSA250ABGD4	KSA250ABGD4	KSA400ABGD4	KSA630ABGD4	KSA630ABGD4	KSA1000ABGD4	KSA1000ABGD4
	3L+PEN	KSA250ABGD5	KSA250ABGD5	KSA250ABGD5	KSA400ABGD5	KSA630ABGD5	KSA630ABGD5	KSA1000ABGD5	KSA1000ABGD5
Flange units									
	3L+N+PE	KSA250AE4	KSA250AE4	KSA250AE4	KSA400AE4	KSA630AE4	KSA630AE4	KSA1000AE4	KSA1000AE4
Accessories for feed units									
For Smart tap-off units									
Box for measurement devices		KSA250ABCB4	KSA250ABCB4	KSA250ABCB4	KSA400ABCB4	-	-	-	-
FL21 cable plates									
For AB Feed units		KSA250ABZFL21	KSA250ABZFL21	KSA250ABZFL21	KSA400ABZFL21	KSA630ABZFL21	KSA630ABZFL21	KSA1000ABZFL21	KSA1000ABZFL21
For ABT Feed units		KSA250ABTZFL21	KSA250ABTZFL21	KSA250ABTZFL21	KSA400ABTZFL21	KSA630ABTZFL21	KSA630ABTZFL21	KSA1000ABTZFL21	KSA1000ABTZFL21







Straight lengths

Horizontal mounting for distribution									
With high density outlets - 3L+N+PE									
1500 mm (6 or 4 outlets)		KSA250ED4156	KSA250ED4156	KSA250ED4156	KSA400ED4156	KSA630ED4154	KSA630ED4154	KSA1000ED4154	KSA1000ED4154
2000 mm (8 or 6 outlets)		KSA250ED4208	KSA250ED4208	KSA250ED4208	KSA400ED4208	KSA630ED4206	KSA630ED4206	KSA1000ED4206	KSA1000ED4206
With high density outlets - 3L+PE									
3000 mm (12 or 6 outlets)		KSA250ED33012	KSA250ED33012	KSA250ED33012	KSA400ED33012	KSA500ED3306	KSA630ED3306	KSA800ED3306	-
5000 mm (20 or 10 outlets)		KSA250ED35020	KSA250ED35020	KSA250ED35020	KSA400ED35020	KSA500ED35010	KSA630ED35010	KSA800ED35010	-
For transport (without outlets)									
Fixed dimension - 3L+N+PE									
3000 mm		KSA250ET430	KSA250ET430	KSA250ET430	KSA400ET430	KSA500ET430	KSA630ET430	KSA800ET430	KSA1000ET430
5000 mm		KSA250ET450	KSA250ET450	KSA250ET450	KSA400ET450	KSA500ET450	KSA630ET450	KSA800ET450	KSA1000ET450
Made-to-measure - 3L+N+PE									
500 to 1900 mm		KSA250ET43A	KSA250ET43A	KSA250ET43A	KSA400ET43A	KSA630ET43A	KSA630ET43A	KSA1000ET43A	KSA1000ET43A
Made-to-measure - With 1 fire barrier free positioning - 3L+N+PE									
800 to 1900 mm		KSA250ET43AF	KSA250ET43AF	KSA250ET43AF	KSA400ET43AF	KSA500ET43AF	KSA630ET43AF	KSA1000ET43AF	KSA1000ET43AF

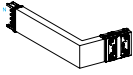
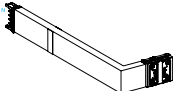
"KS*****": Reference specifically adapted to the rating of the busbar trunking

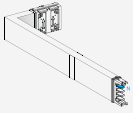
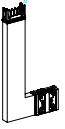
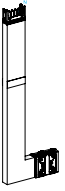
"KS*****": Compatible reference with the rating of the busbar trunking

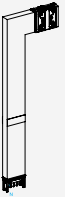
Busbar ratings (A)

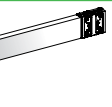
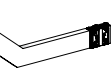
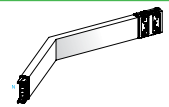
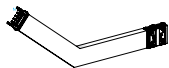
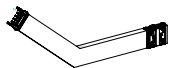
	100	160	250	400	500	630	800	1000
Change direction elements								
Elbows - 3L+N+PE								
	<i>A = 200 x B = 200 to 750</i>				<i>A = 290 x B = 290 to 800</i>			
	KSA250DLR41A	KSA250DLR41A	KSA250DLR41A	KSA400DLR41A	KSA630DLR41A	KSA630DLR41A	KSA1000DLR41A	KSA1000DLR41A
	<i>A = 200 to 750 x B = 200</i>				<i>A = 290 to 800 x B = 290</i>			
	KSA250DLR42A	KSA250DLR42A	KSA250DLR42A	KSA400DLR42A	KSA630DLR42A	KSA630DLR42A	KSA1000DLR42A	KSA1000DLR42A
	<i>A = 200 to 750 x B = 200 to 750</i>				<i>A = 290 to 800 x B = 290 to 800</i>			
	KSA250DLR43A	KSA250DLR43A	KSA250DLR43A	KSA400DLR43A	KSA630DLR43A	KSA630DLR43A	KSA1000DLR43A	KSA1000DLR43A
With fire barrier	<i>A = 200 x B = 700 to 1200</i>				<i>A = 290 x B = 700 to 1200</i>			
	KSA250DLR41F	KSA250DLR41F	KSA250DLR41F	KSA400DLR41F	KSA630DLR41F	KSA630DLR41F	KSA1000DLR41F	KSA1000DLR41F
	<i>A = 700 to 1200 x B = 200</i>				<i>A = 700 to 1200 x B = 290</i>			
	KSA250DLR42F	KSA250DLR42F	KSA250DLR42F	KSA400DLR42F	KSA630DLR42F	KSA630DLR42F	KSA1000DLR42F	KSA1000DLR42F
	<i>A = 200 to 750 x B = 700 to 1200</i>				<i>A = 290 to 800 x B = 700 to 1200</i>			
	KSA250DLR43F	KSA250DLR43F	KSA250DLR43F	KSA400DLR43F	KSA630DLR43F	KSA630DLR43F	KSA1000DLR43F	KSA1000DLR43F
	<i>A = 200 x B = 200 to 750</i>				<i>A = 290 x B = 290 to 800</i>			
	KSA250DLL41A	KSA250DLL41A	KSA250DLL41A	KSA400DLL41A	KSA630DLL41A	KSA630DLL41A	KSA1000DLL41A	KSA1000DLL41A
	<i>A = 200 to 750 x B = 200</i>				<i>A = 290 to 800 x B = 290</i>			
With fire barrier	KSA250DLL42A	KSA250DLL42A	KSA250DLL42A	KSA400DLL42A	KSA630DLL42A	KSA630DLL42A	KSA1000DLL42A	KSA1000DLL42A
	<i>A = 200 to 750 x B = 200 to 750</i>				<i>A = 290 to 800 x B = 290 to 800</i>			
	KSA250DLL43A	KSA250DLL43A	KSA250DLL43A	KSA400DLL43A	KSA630DLL43A	KSA630DLL43A	KSA1000DLL43A	KSA1000DLL43A
	<i>A = 200 x B = 700 to 1200</i>				<i>A = 290 x B = 700 to 1200</i>			
	KSA250DLL41F	KSA250DLL41F	KSA250DLL41F	KSA400DLL41F	KSA630DLL41F	KSA630DLL41F	KSA1000DLL41F	KSA1000DLL41F
	<i>A = 700 to 1200 x B = 200</i>				<i>A = 700 to 1200 x B = 290</i>			
	KSA250DLL42F	KSA250DLL42F	KSA250DLL42F	KSA400DLL42F	KSA630DLL42F	KSA630DLL42F	KSA1000DLL42F	KSA1000DLL42F
	<i>A = 200 to 750 x B = 700 to 1200</i>				<i>A = 290 to 800 x B = 700 to 1200</i>			
	KSA250DLR43F	KSA250DLR43F	KSA250DLR43F	KSA400DLR43F	KSA630DLR43F	KSA630DLR43F	KSA1000DLR43F	KSA1000DLR43F
	<i>A = 250 x B = 250 to 750</i>				<i>A = 290 x B = 290 to 800</i>			
	KSA250DLE41A	KSA250DLE41A	KSA250DLE41A	KSA400DLE41A	KSA630DLE41A	KSA630DLE41A	KSA1000DLE41A	KSA1000DLE41A
	<i>A = 250 to 750 x B = 250</i>				<i>A = 290 to 800 x B = 290</i>			
With fire barrier	KSA250DLE42A	KSA250DLE42A	KSA250DLE42A	KSA400DLE42A	KSA630DLE42A	KSA630DLE42A	KSA1000DLE42A	KSA1000DLE42A
	<i>A = 250 to 750 x B = 250 to 750</i>				<i>A = 290 to 800 x B = 290 to 800</i>			
	KSA250DLE43A	KSA250DLE43A	KSA250DLE43A	KSA400DLE43A	KSA630DLE43A	KSA630DLE43A	KSA1000DLE43A	KSA1000DLE43A
	<i>A = 250 x B = 700 to 1200</i>				<i>A = 290 x B = 700 to 1200</i>			
	KSA250DLE41F	KSA250DLE41F	KSA250DLE41F	KSA400DLE41F	KSA630DLE41F	KSA630DLE41F	KSA1000DLE41F	KSA1000DLE41F
	<i>A = 700 to 1200 x B = 250</i>				<i>A = 700 to 1200 x B = 290</i>			
	KSA250DLE42F	KSA250DLE42F	KSA250DLE42F	KSA400DLE42F	KSA630DLE42F	KSA630DLE42F	KSA1000DLE42F	KSA1000DLE42F
	<i>A = 250 to 750 x B = 700 to 1200</i>				<i>A = 290 to 800 x B = 700 to 1200</i>			
	KSA250DLE43F	KSA250DLE43F	KSA250DLE43F	KSA400DLE43F	KSA630DLE43F	KSA630DLE43F	KSA1000DLE43F	KSA1000DLE43F
	<i>A = 250 x B = 250 to 750</i>				<i>A = 290 x B = 290 to 800</i>			
	KSA250DLF41A	KSA250DLF41A	KSA250DLF41A	KSA400DLF41A	KSA630DLF41A	KSA630DLF41A	KSA1000DLF41A	KSA1000DLF41A
	<i>A = 250 to 750 x B = 250</i>				<i>A = 290 to 800 x B = 290</i>			
With fire barrier	KSA250DLF42A	KSA250DLF42A	KSA250DLF42A	KSA400DLF42A	KSA630DLF42A	KSA630DLF42A	KSA1000DLF42A	KSA1000DLF42A
	<i>A = 250 to 750 x B = 250 to 750</i>				<i>A = 290 to 800 x B = 290 to 800</i>			
	KSA250DLF43A	KSA250DLF43A	KSA250DLF43A	KSA400DLF43A	KSA630DLF43A	KSA630DLF43A	KSA1000DLF43A	KSA1000DLF43A
	<i>A = 250 x B = 700 to 1200</i>				<i>A = 290 x B = 700 to 1200</i>			
	KSA250DLF41F	KSA250DLF41F	KSA250DLF41F	KSA400DLF41F	KSA630DLF41F	KSA630DLF41F	KSA1000DLF41F	KSA1000DLF41F
	<i>A = 700 to 1200 x B = 250</i>				<i>A = 700 to 1200 x B = 290</i>			
	KSA250DLF42F	KSA250DLF42F	KSA250DLF42F	KSA400DLF42F	KSA630DLF42F	KSA630DLF42F	KSA1000DLF42F	KSA1000DLF42F
	<i>A = 250 to 750 x B = 700 to 1200</i>				<i>A = 290 to 800 x B = 700 to 1200</i>			
	KSA250DLF43F	KSA250DLF43F	KSA250DLF43F	KSA400DLF43F	KSA630DLF43F	KSA630DLF43F	KSA1000DLF43F	KSA1000DLF43F
	<i>A = 200 to 750 x B = 200 to 750 - Angle 95° to 175°</i>				<i>A = 290 to 800 x B = 290 to 800 - Angle 95° to 175°</i>			
	KSA250DLC43B	KSA250DLC43B	KSA250DLC43B	KSA400DLC43B	KSA630DLC43B	KSA630DLC43B	KSA1000DLC43B	KSA1000DLC43B
	<i>A = 250 to 750 x B = 200 to 750 - Angle 95° to 175°</i>				<i>A = 290 to 800 x B = 290 to 800 - Angle 95° to 175°</i>			
	KSA250DLE43B	KSA250DLE43B	KSA250DLE43B	KSA400DLE43B	KSA630DLE43B	KSA630DLE43B	KSA1000DLE43B	KSA1000DLE43B
	KSA250DLF43B	KSA250DLF43B	KSA250DLF43B	KSA400DLF43B	KSA630DLF43B	KSA630DLF43B	KSA1000DLF43B	KSA1000DLF43B

"KS.....": Reference specifically adapted to the rating of the busbar trunking

"KS.....": Compatible reference with the rating of the busbar trunking

Offer overview

Busbar ratings (A)

	100	160	250	400	500	630	800	1000
Change direction elements (cont.)								
Zeds - 3L+N+PE - 2 Turns at 90°								
	A = 200 x B = (200 to 750) x C = 200 KSA250DZCG41A KSA250DZCG41A KSA250DZCG41A KSA400DZCG41A				A = 290 x B = (200 to 800) x C = 290 KSA630DZCG41A KSA630DZCG41A KSA1000DZCG41A KSA1000DZCG41A			
	A = (200 to 750) x B = (200 to 750) x C = (200 to 750) KSA250DZCG43A KSA250DZCG43A KSA250DZCG43A KSA400DZCG43A				A = (290 to 800) x B = (200 to 800) x C = (290 to 800) KSA630DZCG43A KSA630DZCG43A KSA1000DZCG43A KSA1000DZCG43A			
	A = 200 x B = (700 to 1200) x C = 200 KSA250DZCG41F KSA250DZCG41F KSA250DZCG41F KSA400DZCG41F				A = 290 x B = (700 to 1200) x C = 290 KSA630DZCG41F KSA630DZCG41F KSA1000DZCG41F KSA1000DZCG41F			
	A = (200 to 750) x B = (200 to 750) x C = (200 to 750) for branches without fire barrier and 700 to 1200 for the branch with the fire barrier KSA250DZCG43F KSA250DZCG43F KSA250DZCG43F KSA400DZCG43F				A = (290 to 800) x B = (200 to 800) x C = (290 to 800) for branches without fire barrier and 700 to 1200 for the branch with the fire barrier KSA630DZCG43F KSA630DZCG43F KSA1000DZCG43F KSA1000DZCG43F			
	A = 200 x B = (200 to 750) x C = 200 KSA250DZCH41A KSA250DZCH41A KSA250DZCH41A KSA400DZCH41A				A = 290 x B = (200 to 800) x C = 290 KSA630DZCH41A KSA630DZCH41A KSA1000DZCH41A KSA1000DZCH41A			
	A = (200 to 750) x B = (200 to 750) x C = (200 to 750) KSA250DZCH43A KSA250DZCH43A KSA250DZCH43A KSA400DZCH43A				A = (290 to 800) x B = (200 to 800) x C = (290 to 800) KSA630DZCH43A KSA630DZCH43A KSA1000DZCH43A KSA1000DZCH43A			
	A = 200 x B = (200 to 1200) x C = 200 for branches without fire barrier and 700 to 1200 for the branch with the fire barrier KSA250DZCH41F KSA250DZCH41F KSA250DZCH41F KSA400DZCH41F				A = 290 x B = (700 to 1200) x C = 290 for branches without fire barrier and 700 to 1200 for the branch with the fire barrier KSA630DZCH41F KSA630DZCH41F KSA1000DZCH41F KSA1000DZCH41F			
	A = (200 to 750) x B = (200 to 750) x C = (200 to 750) KSA250DZCH43F KSA250DZCH43F KSA250DZCH43F KSA400DZCH43F				A = (290 to 800) x B = (200 to 800) x C = (290 to 800) KSA630DZCH43F KSA630DZCH43F KSA1000DZCH43F KSA1000DZCH43F			
	A = 250 x B = (200 to 750) x C = 250 KSA250DZE41A KSA250DZE41A KSA250DZE41A KSA400DZE41A				A = 290 x B = (200 to 800) x C = 290 KSA630DZE41A KSA630DZE41A KSA1000DZE41A KSA1000DZE41A			
	A = (250 to 750) x B = (200 to 750) x C = (250 to 750) KSA250DZE43A KSA250DZE43A KSA250DZE43A KSA400DZE43A				A = (290 to 800) x B = (200 to 800) x C = (290 to 800) KSA630DZE43A KSA630DZE43A KSA1000DZE43A KSA1000DZE43A			
	A = 250 x B = (700 to 1200) x C = 250 KSA250DZE41F KSA250DZE41F KSA250DZE41F KSA400DZE41F				A = 290 x B = (700 to 1200) x C = 290 KSA630DZE41F KSA630DZE41F KSA1000DZE41F KSA1000DZE41F			
	A = (250 to 750) x B = (200 to 750) x C = (250 to 750) for branches without fire barrier and 700 to 1200 for the branch with the fire barrier KSA250DZE43F KSA250DZE43F KSA250DZE43F KSA400DZE43F				A = (290 to 800) x B = (200 to 800) x C = (290 to 800) for branches without fire barrier and 700 to 1200 for the branch with the fire barrier KSA630DZE43F KSA630DZE43F KSA1000DZE43F KSA1000DZE43F			
Multiples - 3L+N+PE - 2 Turns at 90°								
	A = 250 x B = (200 to 750) x C = 200 KSA250DMBL41A KSA250DMBL41A KSA250DMBL41A KSA400DMBL41A				A = 290 x B = (200 to 800) x C = 290 KSA630DMBL41A KSA630DMBL41A KSA1000DMBL41A KSA1000DMBL41A			
	A = (250 to 750) x B = (200 to 750) x C = (200 to 750) KSA250DMBL43A KSA250DMBL43A KSA250DMBL43A KSA400DMBL43A				A = (290 to 800) x B = (200 to 800) x C = (290 to 800) KSA630DMBL43A KSA630DMBL43A KSA1000DMBL43A KSA1000DMBL43A			
	A = 250 x B = (700 to 1200) x C = 200 KSA250DMBL41F KSA250DMBL41F KSA250DMBL41F KSA400DMBL41F				A = 290 x B = (700 to 1200) x C = 290 KSA630DMBL41F KSA630DMBL41F KSA1000DMBL41F KSA1000DMBL41F			
	A = (250 to 750) x B = (200 to 750) x C = (200 to 750) for branches without fire barrier and 700 to 1200 for the branch with the fire barrier KSA250DMBL43F KSA250DMBL43F KSA250DMBL43F KSA400DMBL43F				A = (290 to 800) x B = (200 to 800) x C = (290 to 800) for branches without fire barrier and 700 to 1200 for the branch with the fire barrier KSA630DMBL43F KSA630DMBL43F KSA1000DMBL43F KSA1000DMBL43F			
	A = 250 x B = (200 to 750) x C = 200 KSA250DMCL41A KSA250DMCL41A KSA250DMCL41A KSA400DMCL41A				A = 290 x B = (200 to 750) x C = 290 KSA630DMCL41A KSA630DMCL41A KSA1000DMCL41A KSA1000DMCL41A			
	A = (250 to 750) x B = (200 to 750) x C = (200 to 750) KSA250DMCL43A KSA250DMCL43A KSA250DMCL43A KSA400DMCL43A				A = (290 to 800) x B = (200 to 800) x C = (290 to 800) KSA630DMCL43A KSA630DMCL43A KSA1000DMCL43A KSA1000DMCL43A			
	A = 250 x B = (700 to 1200) x C = 200 KSA250DMCL41F KSA250DMCL41F KSA250DMCL41F KSA400DMCL41F				A = 290 x B = (700 to 1200) x C = 290 KSA630DMCL41F KSA630DMCL41F KSA1000DMCL41F KSA1000DMCL41F			
	A = (250 to 750) x B = (200 to 750) x C = (200 to 750) for branches without fire barrier and 700 to 1200 for the branch with the fire barrier KSA250DMCL43F KSA250DMCL43F KSA250DMCL43F KSA400DMCL43F				A = (290 to 800) x B = (200 to 800) x C = (290 to 800) for branches without fire barrier and 700 to 1200 for the branch with the fire barrier KSA630DMCL43F KSA630DMCL43F KSA1000DMCL43F KSA1000DMCL43F			
	A = 250 x B = (200 to 750) x C = 200 KSA250DMBK41A KSA250DMBK41A KSA250DMBK41A KSA400DMBK41A				A = 290 x B = (200 to 800) x C = 290 KSA630DMBK41A KSA630DMBK41A KSA1000DMBK41A KSA1000DMBK41A			
	A = (250 to 750) x B = (200 to 750) x C = (200 to 750) KSA250DMBK43A KSA250DMBK43A KSA250DMBK43A KSA400DMBK43A				A = (290 to 800) x B = (200 to 800) x C = (290 to 800) KSA630DMBK43A KSA630DMBK43A KSA1000DMBK43A KSA1000DMBK43A			
	A = 250 x B = (700 to 1200) x C = 200 KSA250DMBK41F KSA250DMBK41F KSA250DMBK41F KSA400DMBK41F				A = 290 x B = (700 to 1200) x C = 290 KSA630DMBK41F KSA630DMBK41F KSA1000DMBK41F KSA1000DMBK41F			
	A = (250 to 750) x B = (200 to 750) x C = (200 to 750) for branches without fire barrier and 700 to 1200 for the branch with the fire barrier KSA250DMBK43F KSA250DMBK43F KSA250DMBK43F KSA400DMBK43F				A = (290 to 800) x B = (200 to 800) x C = (290 to 800) for branches without fire barrier and 700 to 1200 for the branch with the fire barrier KSA630DMBK43F KSA630DMBK43F KSA1000DMBK43F KSA1000DMBK43F			
	A = 250 x B = (200 to 750) x C = 200 KSA250DMCK41A KSA250DMCK41A KSA250DMCK41A KSA400DMCK41A				A = 290 x B = (200 to 800) x C = 290 KSA630DMCK41A KSA630DMCK41A KSA1000DMCK41A KSA1000DMCK41A			
	A = (250 to 750) x B = (200 to 750) x C = (200 to 750) KSA250DMCK43A KSA250DMCK43A KSA250DMCK43A KSA400DMCK43A				A = (290 to 800) x B = (200 to 800) x C = (290 to 800) KSA630DMCK43A KSA630DMCK43A KSA1000DMCK43A KSA1000DMCK43A			
	A = 250 x B = (700 to 1200) x C = 200 KSA250DMCK41F KSA250DMCK41F KSA250DMCK41F KSA400DMCK41F				A = 290 x B = (700 to 1200) x C = 290 KSA630DMCK41F KSA630DMCK41F KSA1000DMCK41F KSA1000DMCK41F			
	A = (250 to 750) x B = (200 to 750) x C = (200 to 750) for branches without fire barrier and 700 to 1200 for the branch with the fire barrier KSA250DMCK43F KSA250DMCK43F KSA250DMCK43F KSA400DMCK43F				A = (290 to 800) x B = (200 to 800) x C = (290 to 800) for branches without fire barrier and 700 to 1200 for the branch with the fire barrier KSA630DMCK43F KSA630DMCK43F KSA1000DMCK43F KSA1000DMCK43F			
Tees & Crosses								
	To connect 3 lines: 3 x 165 KSA250DTC40 KSA250DTC40 KSA250DTC40 KSA400DTC40				To connect 3 lines: 3 x 290 KSA630DTC40 KSA630DTC40 KSA1000DTC40 KSA1000DTC40			
	To connect 4 lines: 4 x 165 KSA250DXC40 KSA250DXC40 KSA250DXC40 KSA400DXC40				To connect 4 lines: 4 x 290 KSA630DXC40 KSA630DXC40 KSA1000DXC40 KSA1000DXC40			

Offer overview

Busbar ratings (A)

Rating	Polarity	100	160	250	400	500	630	800	1000	
Connectors & Tap-off units*										
Disconnection by opening the door										
Delivered equipped with a fuse holder										
For blade-type fuses	630 A	3L+N+PE		-					KSB630SE4	
		3L+PEN		-					KSB630SE5	
Delivered with an Isolator, without protection or mouting plate										
To be customized	50 A	3L+N+PE		KSB50SV4					KSB50SV4	
		3L+PEN		KSB50SV5					KSB50SV5	
	100 A	3L+N+PE		KSB100SV4					KSB100SV4	
		3L+PEN		KSB100SV5					KSB100SV5	
	160 A	3L+N+PE		KSB160SV4					KSB160SV4	
		3L+PEN		KSB160SV5					KSB160SV5	
Switching with a rotary handle located on the door										
Delivered equipped with a mounting plate for 1 circuit breaker + Space provider for CT block										
For NSX circuit breaker + CT block	250 A	3L+N+PE		KSB250DC4TRE					KSB250DC4TRE	
		3L+PEN		KSB250DC5TRE					KSB250DC5TRE	
	400 A	3L+N+PE		-					KSB400DC4TRE	
		3L+PEN		-					KSB400DC5TRE	
Delivered equipped with a plug-in base for 1 circuit breaker										
For NSX circuit breaker PLUG-IN	160 A	3L+N+PE		KSB160DD411					KSB160DD411	
	400 A	3L+N+PE		-					KSB400DD411	
Delivered equipped with a mounting plate for 1 fuse switch-disconnector										
For Fupact INF	160 A	3L+N+PE		KSB160SDF4					KSB160SDF4	
		3L+PEN		KSB160SDF5					KSB160SDF5	
	250 A	3L+N+PE		KSB250SDF4					KSB250SDF4	
		3L+PEN		KSB250SDF5					KSB250SDF5	
	400 A	3L+N+PE		-					KSB400SDF4	
		3L+PEN		-					KSB400SDF5	
	Disconnection by opening the fuse-switch disconnector									
	Delivered equipped with a fuse-switch disconnector Fupact ISFT									
For fuses DIN - NH00	125 A	3L+PEN		KSB125HD5 / KSB125HD502					KSB125HD5 / KSB125HD502	
For fuses DIN - NH1	250 A	3L+PEN		KSA25HD502 / KSB250HD502					KSA25HD502 / KSB250HD502	
For fuses DIN - NH2	400 A	3L+PEN		-					KSA40HD502 / KSB400HD502	
Switching with an electrical handle										
Delivered equipped with a mounting plate for 1 circuit breaker										
For NSX circuit breaker with electrical handle	160 A	3L+N+PE		KSB160DB412					KSB160DB412	
		3L+PEN		KSB160DB512					KSB160DB512	
	250 A	3L+N+PE		KSB250DB412					KSB250DB412	
		3L+PEN		KSB250DB512					KSB250DB512	
	400 A	3L+N+PE		-					KSB400DB412	
		3L+PEN		-					KSB400DB512	
Tap-off units equipped with a surge arrester										
Delivered equipped with a surge arrester										
For line protection against surge	40 kA	3L+N+PE		KSBQPRD					KSBQPRD	

E

Spare parts

Accessories

ZFL21 cable plate for tap-off units	-	KSB160SFZFL21	KSB250DCZFL21	KSB400DCZFL21	-	-	-	-
Accessories for metering devices	KSB63PMP	KSB63PMP	KSB63PMP	KSB63PMP	KSB63PMP	KSB63PMP	KSB63PMP	KSB63PMP
	KSB63EGP	KSB63EGP	KSB63EGP	KSB63EGP	KSB63EGP	KSB63EGP	KSB63EGP	KSB63EGP

IP kits

Former end covers	KSB25FA3	KSB25FA3	KSB25FA3	KSB50FA2	KSB50FA2	KSB80FA2	KSB80FA2	KSB80FA2
Former KS IP54 blanking plate for outlets	KSE80YB2	KSE80YB2	KSE80YB2	KSE80YB2	KSE80YB2	KSE80YB2	KSE80YB2	KSE80YB2
Sprinkler accessory IP54	-	-	-	KSE50YA2	KSE50YA2	-	-	-

Joint blocks - Adapters

From former KS to current KS	KSA250FA4	KSA250FA4	KSA250FA4	KSA400FA4	KSA500FA4	KSA500FA4	KSA800FA4	KSA800FA4
From KS 400 to KS 500/1000 A	-	-	-	KSA500FR425	KSA500FR425	KSA500FR425	KSA500FR425	KSA500FR425
for KS 100 to 250A	KSB25YA4	KSB25YA4	KSB25YA4					

* See compatibility page for mounting limitations

"KS*****": Reference specifically adapted to the rating of the busbar trunking

"KS*****": Compatible reference with the rating of the busbar trunking

Advanced offer

Feed units

Right mounting

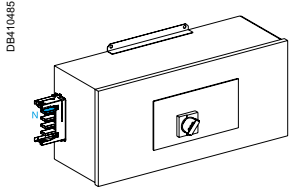

KSA250 and 400 ABDD

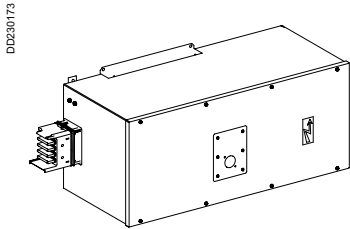

KSA630 and 1000 ABDD

Mounted on the busway For line protection with a NSX (not delivered)

Cat. n°	KSA250ABDD4	KSA400ABDD4	KSA630ABDD4	KSA1000ABDD4
Compatible with	KSA100 to 250	KSA400	KSA500 to 1000	KSA500 to 1000

A in the line (mm)	742	860	1258	1267
--------------------	-----	-----	------	------

Rating (A)	250	400	630	1000
Polarity	3L + N + PE	3L + N + PE	3L + N + PE	3L + N + PE
Phase Diagram				

Cabling				
Protection Type (Not Supplied)	NSX250 N, H, L	NSX400 N, H, L	NSX630 N, H, L	NS1000

Input Type	Alu. plate 300 x 267 x 3	Alu. plate 340 x 267 x 3	Alu. plate 446 x 378 x 3	Alu. plate 446 x 458 x 3
------------	-----------------------------	-----------------------------	-----------------------------	-----------------------------

Available Area (mm)	240 x 220	280 x 220	386 x 330	386 x 410
---------------------	-----------	-----------	-----------	-----------

Maximum Cable size (mm ²)	4 x 240	4 x 300 or 8 x 120	4 x 300 or 8 x 240	12 x 300
---------------------------------------	---------	--------------------	--------------------	----------

Connection	On NSX terminals	On NSX terminals	On NSX terminals	On NS terminals
------------	------------------	------------------	------------------	-----------------

Capability Per Phase	See Compact NSX catalog	See Compact NSX catalog	See Compact NSX catalog	See Compact NS1000 catalog
----------------------	-------------------------	-------------------------	-------------------------	----------------------------

	NSX250: Extended rotary handle LV429338	NSX400: Extended rotary handle LV432598	NSX630: Extended rotary handle LV432598	NS 1000: Extended rotary handle 33878
--	---	---	---	---------------------------------------

Additional Characteristics				
IP	IP55	IP55	IP55	IP55
Color	White	White	White	White
Weight (kg)	17,1	22,2	39,2	52
Selling Unit	1	1	1	1
MOQ	1	1	1	1

Supplied with an End cover

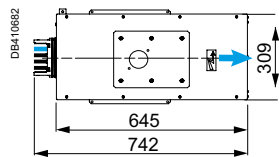

KSA250ABDD4

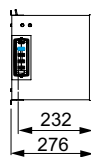

KSA400ABDD4

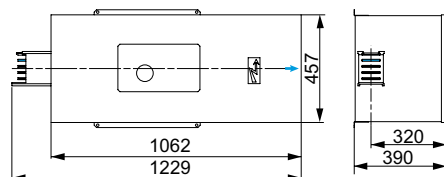
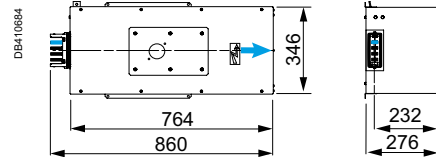

KSA630ABDD4

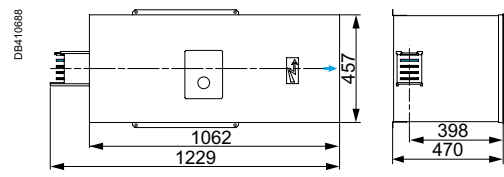

KSA1000ABDD4

Advanced offer

Feed units

Right mounting

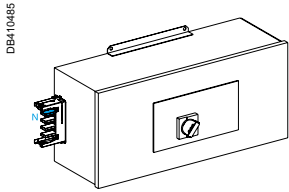

KSA250 and 400 ABDD

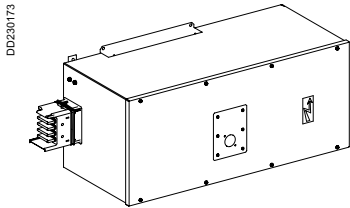

KSA630 and 1000 ABDD

Mounted on the busway For line protection with a NSX (not delivered)

Cat. n°	KSA250ABDD5	KSA400ABDD5	KSA630ABDD5	KSA1000ABDD5
Compatible with	KSA100 to 250	KSA400	KSA500 to 1000	KSA500 to 1000
A in the line (mm)	742	860	1258	1267
Rating (A)	250	400	630	1000
Polarity	3L + PEN	3L + PEN	3L + PEN	3L + PEN
Phase Diagram				
Cabling				
Protection Type (Not Supplied)	NSX250 N, H, L	NSX400 N, H, L	NSX630 N, H, L	NS1000
Input Type	Alu. plate 300 x 267 x 3	Alu. plate 340 x 267 x 3	Alu. plate 446 x 378 x 3	Alu. plate 446 x 458 x 3
Available Area (mm)	240 x 220	280 x 220	386 x 330	386 x 410
Maximum Cable size (mm²)	4 x 240	4 x 300 or 8 x 120	4 x 300 or 8 x 240	12 x 300
Connection	On NSX terminals	On NSX terminals	On NSX terminals	On NS terminals
Capability Per Phase	See Compact NSX catalog	See Compact NSX catalog	See Compact NSX catalog	See Compact NS1000 catalog
	NSX250: Extended rotary handle LV429338	NSX400: Extended rotary handle LV432598	NSX630: Extended rotary handle LV432598	NS 1000: Extended rotary handle 33878

Additional Characteristics

IP	IP55	IP55	IP55	IP55
Color	White	White	White	White
Weight (kg)	17,3	22,6	39,9	53,5
Selling Unit	1	1	1	1
MOQ	1	1	1	1

Supplied with an End cover

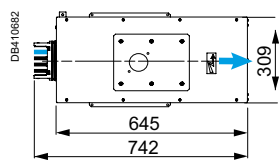

KSA250ABDD5

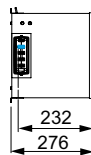

KSA400ABDD5

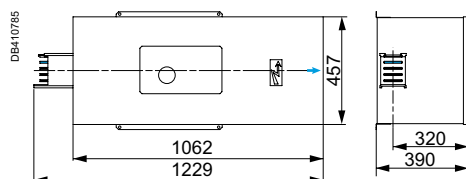
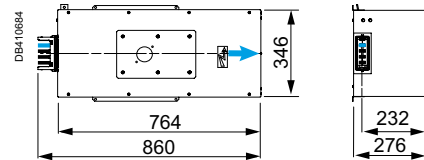

KSA630ABDD5

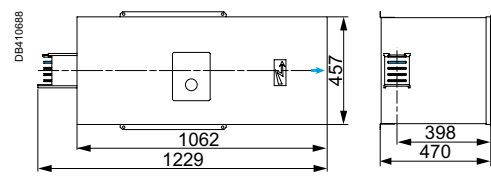

KSA1000ABDD5

Advanced offer

Feed units

Left mounting

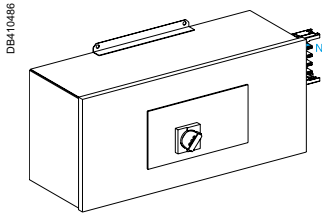

KSA250 and 400 ABGD

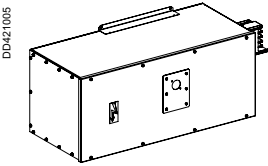

KSA630 and 1000 ABGD

Mounted on the busway For line protection with a NSX (not delivered)

Cat. n°	KSA250ABGD4	KSA400ABGD4	KSA630ABGD4	KSA1000ABGD4
Compatible with	KSA100 to 250	KSA400	KSA500 to 1000	KSA500 to 1000
A in the line (mm)	742	860	1258	1267
Rating (A)	250	400	630	1000
Polarity	3L + N + PE	3L + N + PE	3L + N + PE	3L + N + PE
Phase Diagram				
Cabling				
Protection Type (Not Supplied)	NSX250 N, H, L	NSX400 N, H, L	NSX630 N, H, L	NS1000
Input Type	Alu. plate 300 x 267 x 3	Alu. plate 340 x 267 x 3	Alu. plate 446 x 378 x 3	Alu. plate 446 x 458 x 3
Available Area (mm)	240 x 220	280 x 220	386 x 330	386 x 410
Maximum Cable size (mm²)	4 x 240	4 x 300 or 8 x 120	4 x 300 or 8 x 240	12 x 300
Connection	On NSX terminals	On NSX terminals	On NSX terminals	On NS terminals
Capability Per Phase	See Compact NSX catalog	See Compact NSX catalog	See Compact NSX catalog	See Compact NS1000 catalog
	NSX250: Extended rotary handle LV429338	NSX400: Extended rotary handle LV432598	NSX630: Extended rotary handle LV432598	NS 1000: Extended rotary handle 33878

Additional Characteristics

IP	IP55	IP55	IP55	IP55
Color	White	White	White	White
Weight (kg)	17,3	22,7	39,2	54
Selling Unit	1	1	1	1
MOQ	1	1	1	1

Supplied with an End cover

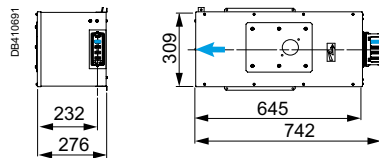

KSA250ABGD4

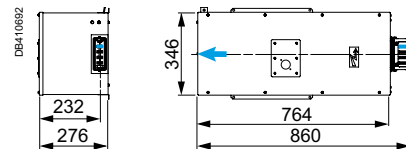

KSA400ABGD4

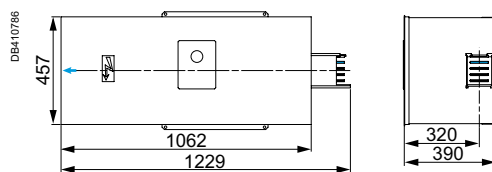

KSA630ABGD4

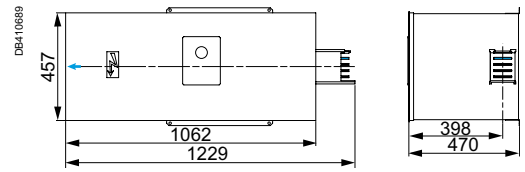

KSA1000ABGD4

Advanced offer

Feed units

Left mounting

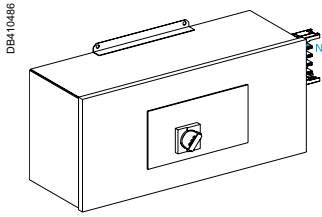

KSA250 and 400 ABGD

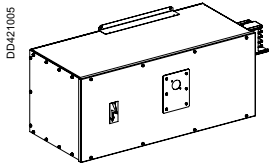

KSA630 and 1000 ABGD

Mounted on the busway For line protection with a NSX (not delivered)

Cat. n°	KSA250ABGD5	KSA400ABGD5	KSA630ABGD5	KSA1000ABGD5
Compatible with	KSA100 to 250	KSA400	KSA500 to 1000	KSA500 to 1000
A in the line (mm)	742	860	1258	1267
Rating (A)	250	400	630	1000
Polarity	3L + PEN	3L + PEN	3L + PEN	3L + PEN
Phase Diagram				
Cabling				
Protection Type (Not Supplied)	NSX250 N, H, L	NSX400 N, H, L	NSX630 N, H, L	NS1000
Input Type	Alu. plate 300 x 267 x 3	Alu. plate 340 x 267 x 3	Alu. plate 446 x 378 x 3	Alu. plate 446 x 458 x 3
Available Area (mm)	240 x 220	280 x 220	386 x 330	386 x 410
Maximum Cable size (mm²)	4 x 240	4 x 300 or 8 x 120	4 x 300 or 8 x 240	12 x 300
Connection	On NSX terminals	On NSX terminals	On NSX terminals	On NS terminals
Capability Per Phase	See Compact NSX catalog	See Compact NSX catalog	See Compact NSX catalog	See Compact NS1000 catalog
	NSX250: Extended rotary handle LV429338	NSX400: Extended rotary handle LV432598	NSX630: Extended rotary handle LV432598	NS 1000: Extended rotary handle 33878

Additional Characteristics

IP	IP55	IP55	IP55	IP55
Color	White	White	White	White
Weight (kg)	17,3	22,6	39,9	56,2
Selling Unit	1	1	1	1
MOQ	1	1	1	1

Supplied with an End cover

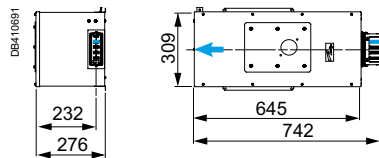

KSA250ABGD5

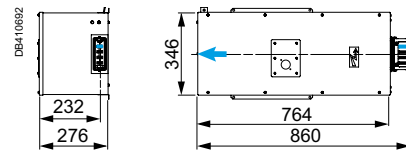

KSA400ABGD5

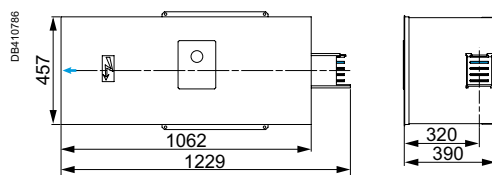

KSA630ABGD5

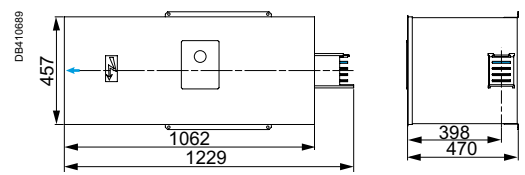

KSA1000ABGD5

Advanced offer

Feed units

Flange units

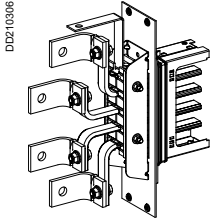

KSA250 and KSA400 AE

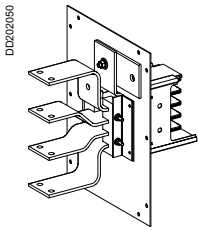

KSA630 and KSA1000 AE

**Mounted on the switchboard
Without line protection**

Cat. n°	KSA250AE4	KSA400AE4	KSA630AE4	KSA1000AE4
Compatible with	KSA100 to 250	KSA400	KSA500 to 1000	KSA500 to 1000
A in the line (mm)	100	100	172	172
Rating (A)	250	400	630	1000
Polarity	3L + N + PE	3L + N + PE	3L + N + PE	3L + N + PE
Phase Diagram				
Cabling				
Protection Type (Not Supplied)	None	None	None	None
Input Type	-	-	-	-
Available Area (mm)	-	-	-	-
Maximum Cable size (mm ²)	-	-	-	-
Connection	With Compression Lugs ⁽¹⁾ onto tin-plated aluminum bars	With Compression Lugs ⁽¹⁾ onto tin-plated aluminum bars	With Compression Lugs ⁽¹⁾ onto tin-plated aluminum bars	With Compression Lugs ⁽¹⁾ onto tin-plated aluminum bars
Capability Per Phase	1 x Ø13 mm (L) + 1 x Ø9 mm (PE)	1 x Ø13 mm (L) + 1 x Ø9 mm (PE)	2 x Ø11 mm (L) + 1 x Ø14 mm (PE)	4 x Ø11 mm (L) + 1 x Ø14 mm (PE)
	(¹) Not included	(¹) Not included	(¹) Not included	(¹) Not included

Additional Characteristics

IP	-	-	-	-
Color	White	White	White	White
Weight (kg)	2	2,1	10,6	12
Selling Unit	1	1	1	1
MOQ	1	1	1	1

Supplied with an End cover

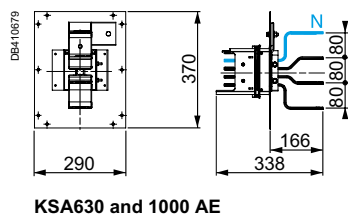
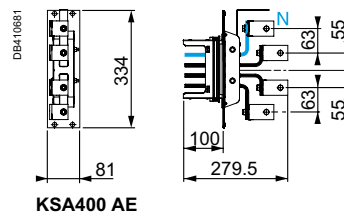
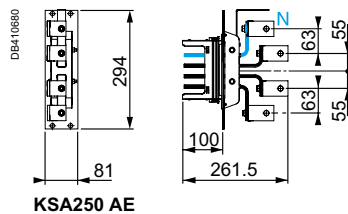

Advanced offer

Feed units (Accessories)

Accessories for feed units

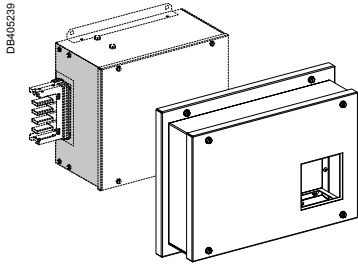

For Smart tap-off units
Box for measurement devices

Cat. n°	KSA250ACB4	KSA400ACB4
Compatible with	KSA250AB4	KSA400AB4
Rating (A)	250	400
Polarity	-	-

KSA250ACB4

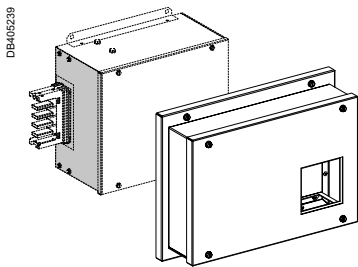

KSA400ACB4

Additional Characteristics		
IP	IP55	IP55
Color	White	White
Weight (kg)	4,8	5,3
Selling Unit	1	1
MOQ	1	1

It is designed to replace the lids of the compatible feed unit and to install measurement system PM5350 + Protection (Acti9)

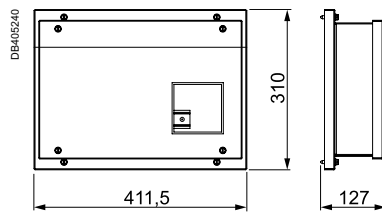

KSA250ACB4

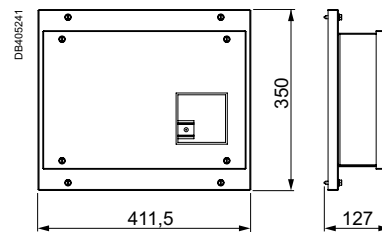

KSA400ACB4



Advanced offer

Feed units (Accessories)

Accessories for feed units

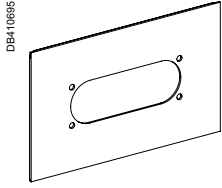

KSA250ABZFL21

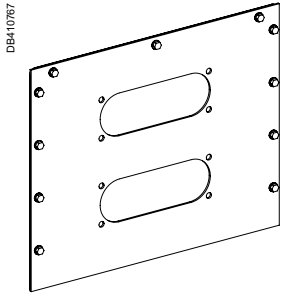

KSA630ABZFL21

Plate for FL21 flexible cable gland
Plate for AB Feed units, compatible with FL21 flexible cable gland

Cat. n°	KSA250ABZFL21	KSA400ABZFL21	KSA630ABZFL21	KSA1000ABZFL21
Compatible with	KSA250AB4	KSA400AB4	KSA630AB4	KSA1000AB4

Rating (A)	250	400	400	1000
Polarity	-	-	-	-

Additional Characteristics				
IP	-	-	-	-
Color	White	White	White	White
Weight (kg)	0,73	0,542	0,857	1,764
Selling Unit	1	1	1	1
MOQ	1	1	1	1

FL21 cable gland can be found on schneider-electric.com

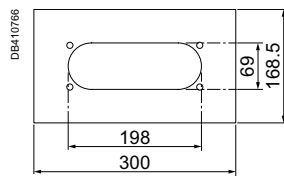

KSA250ABZFL21

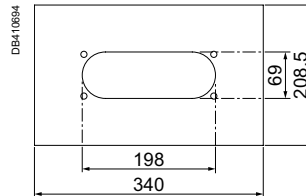

KSA400ABZFL21

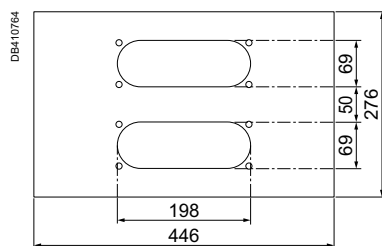

KSA630ABZFL21

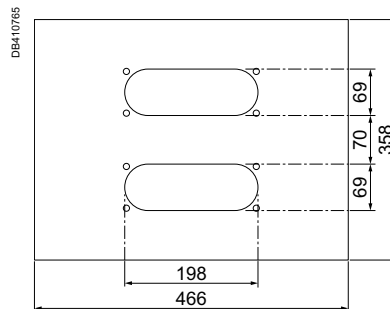

KSA1000ABZFL21

Advanced offer

Feed units (Accessories)

Accessories for feed units

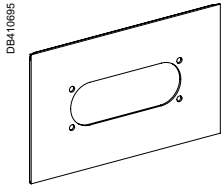

KSA250ABTZFL21

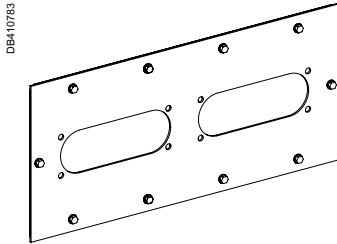

KSA630ABTZFL21

Plate for FL21 flexible cable gland
Plate for ABT Feed units, compatible with FL21 flexible cable gland

Cat. n°	KSA250ABTZFL21	KSA400ABTZFL21	KSA630ABTZFL21	KSA1000ABTZFL21
Compatible with	KSA250ABT4	KSA400ABT4	KSA630ABT4	KSA1000ABT4

Rating (A)	250	400	630	1000
Polarity	-	-	-	-

Additional Characteristics				
IP	-	-	-	-
Color	White	White	White	White
Weight (kg)	0,845	0,792	0,783	1,7
Selling Unit	1	1	1	1
MOQ	1	1	1	1

FL21 cable gland can be found on schneider-electric.com

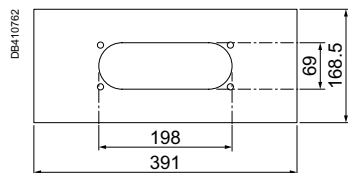

KSA250ABTZFL21

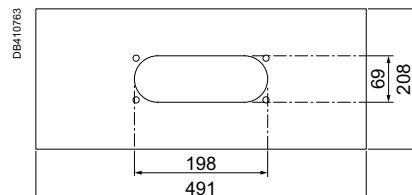

KSA250/400 ABT ZFL21

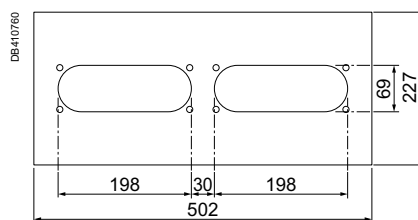

KSA630ABTZFL21

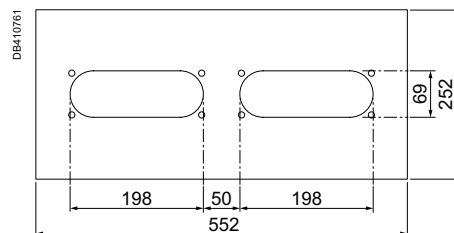

KSA1000ABTZFL21



Advanced offer

Straight lengths

With High density outlets - 1.5 m

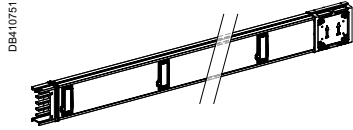

KSA100 to 400 ED •15

For Distribution
Horizontal mounting

Cat. n°	KSA250ED4156	KSA400ED4156	KSA630ED4154	KSA1000ED4154
Compatible with	KSA100 to 250	KSA400	KSA500 to 1000	KSA500 to 1000
A in the line (mm)	1500	1500	1500	1500
Rating (A)	250	400	630	1000
Polarity	3L + N + PE	3L + N + PE	3L + N + PE	3L + N + PE

Characteristics

Number	6	6	4	4
Of Outlet(s)				
Outlet(s) Position	3 on each side	3 on each side	2 on each side	2 on each side
Distance Between 500	500	500	500 or 750	500 or 750
Outlets (mm)				
Fire Barrier	No	No	No	No
Fire Barrier Position	-	-	-	-

Additional Characteristics

IP	IP55	IP55	IP55	IP55
Color	White	White	White	White
Weight (kg)	8,55	10,85	19	29,5
Selling Unit	1	1	1	1
MOQ	1	1	1	1

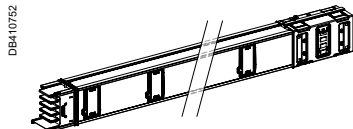

KSA500 to 1000 ED •15

With High density outlets - 2 m

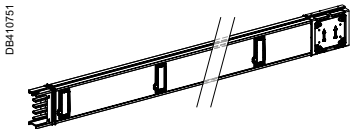

KSA100 to 400 ED •20

For Distribution
Horizontal mounting

Cat. n°	KSA250ED4208	KSA400ED4208	KSA630ED4206	KSA1000ED4206
Compatible with	KSA100 to 250	KSA400	KSA500 to 1000	KSA500 to 1000
A in the line (mm)	2000	2000	2000	2000
Rating (A)	250	400	630	1000
Polarity	3L + N + PE	3L + N + PE	3L + N + PE	3L + N + PE

Characteristics

Number	8	8	6	6
Of Outlet(s)				
Outlet(s) Position	4 on each side	4 on each side	3 on each side	3 on each side
Distance Between 500	500	500	500 or 750	500 or 750
Outlets (mm)				
Fire Barrier	No	No	No	No
Fire Barrier Position	-	-	-	-

Additional Characteristics

IP	IP55	IP55	IP55	IP55
Color	White	White	White	White
Weight (kg)	10,85	13,9	25,5	38,05
Selling Unit	1	1	1	1
MOQ	1	1	1	1

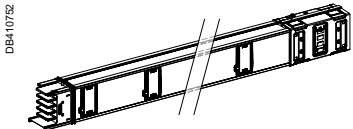

KSA500 to 1000 ED •20

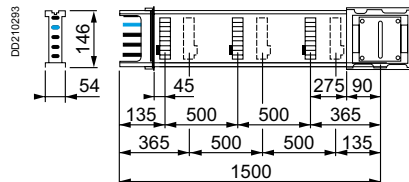

KSA100 to 400 ED •15

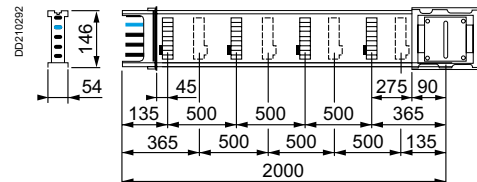

KSA100 to 400 ED •20

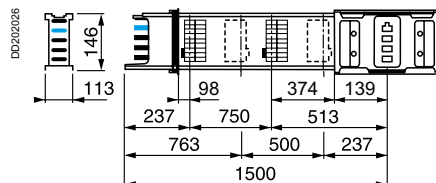

KSA500 to 1000 ED •15

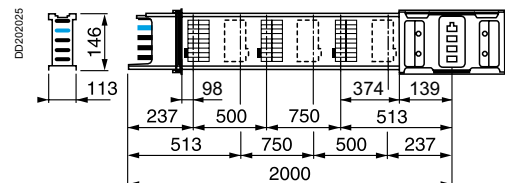

KSA500 to 1000 ED •20

Advanced offer

Straight lengths

With High density outlets - 3 m - 3L + PE

DB410780

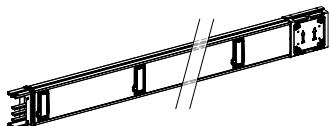

KSA100 to 400 ED •30

For Distribution Horizontal mounting

Cat. n°	KSA250ED33012	KSA400ED33012	KSA500ED3306	KSA630ED3306	KSA800ED3306
Compatible with	KSA100 to 250	KSA400	KSA500 to 1000	KSA500 to 1000	KSA500 to 1000
A in the line (mm)	3000	3000	3000	3000	3000
Rating (A)	250	400	500	630	800
Polarity	3L + PE	3L + PE	3L + PE	3L + PE	3L + PE

DB410782

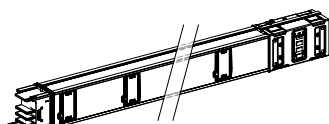

KSA500 to 1000 ED •30

Characteristics					
Number	12	12	6	6	6
Of Outlet(s)					
Outlet(s) Position	6 on each side	6 on each side	3 on each side	3 on each side	3 on each side
Distance Between 500	500	500	1000	1000	1000
Outlets (mm)					
Fire Barrier	No	No	No	No	No
Fire Barrier Position	-	-	-	-	-

Additional Characteristics					
IP	IP55	IP55	IP55	IP55	IP55
Color	White	White	White	White	White
Weight (kg)	13	15	24,9	28,4	31,8
Selling Unit	1	1	1	1	1
MOQ	1	1	1	1	1

With High density outlets - 5 m - 3L + PE

DB410780

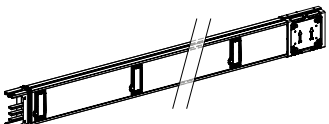

KSA100 to 400 ED •50

For Distribution Horizontal mounting

Cat. n°	KSA250ED35020	KSA400ED35020	KSA500ED35010	KSA630ED35010	KSA800ED35010
Compatible with	KSA100 to 250	KSA400	KSA500 to 1000	KSA500 to 1000	KSA500 to 1000
A in the line (mm)	5000	5000	5000	5000	5000
Rating (A)	250	400	500	630	800
Polarity	3L + PE	3L + PE	3L + PE	3L + PE	3L + PE

DB410782

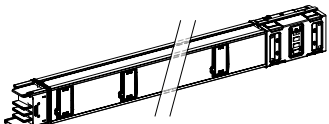

KSA500 to 1000 ED •50

Characteristics					
Number	20	20	10	10	10
Of Outlet(s)					
Outlet(s) Position	10 on each side	10 on each side	5 on each side	5 on each side	5 on each side
Distance Between 500	500	500	1000	1000	1000
Outlets (mm)					
Fire Barrier	No	No	No	No	No
Fire Barrier Position	-	-	-	-	-

Additional Characteristics					
IP	IP55	IP55	IP55	IP55	IP55
Color	White	White	White	White	White
Weight (kg)	21	24	41,875	45	53
Selling Unit	1	1	1	1	1
MOQ	1	1	1	1	1

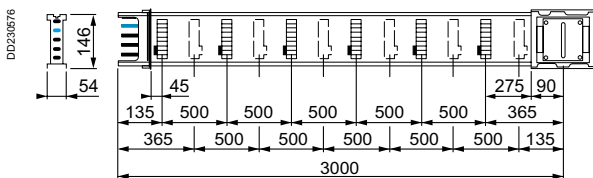

KSA100 to 400 ED •30

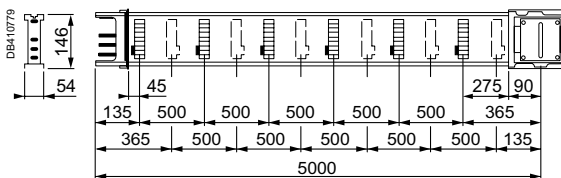

KSA100 to 400 ED •50

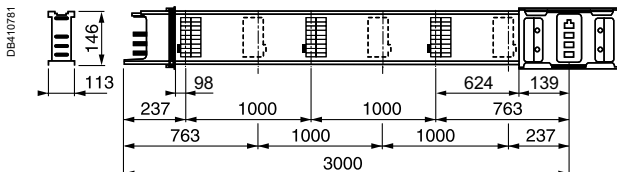

KSA500 to 1000 ED •30

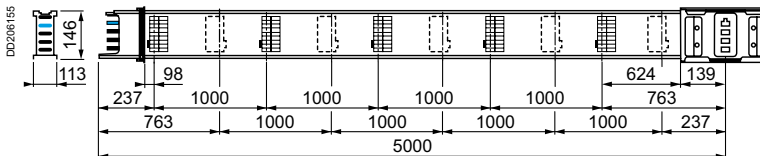

KSA500 to 1000 ED •50

E

Advanced offer

Straight lengths

Fixed dimensions - 3 m

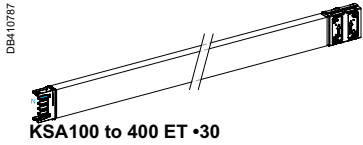

For Transport (without Outlets)
Horizontal mounting

Cat. n°	KSA250ET430	KSA400ET430
Compatible with	KSA100 to 250	KSA400
A in the line (mm)	3000	3000
Rating (A)	250	400
Polarity	3L + N + PE	3L + N + PE

Characteristics		
Fire Barrier	No	No
Fire Barrier	-	-
Position		

Additional Characteristics		
IP	IP55	IP55
Color	White	White
Weight (kg)	-	20,4
Selling Unit	1	1
MOQ	1	1

Fixed dimensions - 3 m

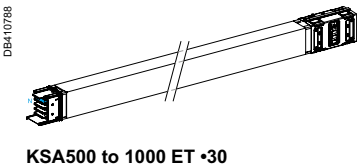

For Transport (without Outlets)
Horizontal mounting

Cat. n°	KSA500ET430	KSA630ET430	KSA800ET430	KSA1000ET430
Compatible with	KSA500 to 1000	KSA500 to 1000	KSA500 to 1000	KSA500 to 1000
A in the line (mm)	3000	3000	3000	3000
Rating (A)	500	630	800	1000
Polarity	3L + N + PE	3L + N + PE	3L + N + PE	3L + N + PE

Characteristics				
Fire Barrier	No	No	No	No
Fire Barrier	-	-	-	-
Position				

Additional Characteristics				
IP	IP55	IP55	IP55	IP55
Color	White	White	White	White
Weight (kg)	34,9	36,4	43,1	55,2
Selling Unit	1	1	1	1
MOQ	1	1	1	1

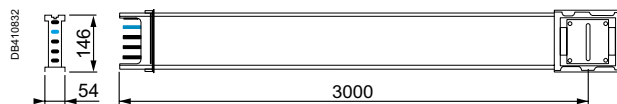

KSA100 to 400 ET •30

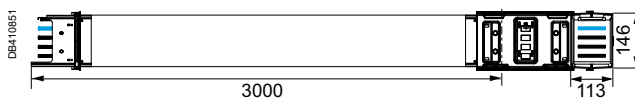

KSA500 to 1000 ET •30

Advanced offer

Straight lengths

Fixed dimensions - 5 m



KSA100 to 400 ET •50

For Transport (without Outlets)
Horizontal mounting

Cat. n°	KSA250ET450	KSA400ET450
Compatible with	KSA100 to 250	KSA400
A in the line (mm)	5000	5000
Rating (A)	250	400
Polarity	3L + N + PE	3L + N + PE

Characteristics		
Fire Barrier	No	No
Fire Barrier	-	-
Position		

Additional Characteristics		
IP	IP55	IP55
Color	White	White
Weight (kg)	-	32,85
Selling Unit	1	1
MOQ	1	1

Fixed dimensions - 5 m



KSA500 to 1000 ET •50

For Transport (without Outlets)
Horizontal mounting

Cat. n°	KSA500ET450	KSA630ET450	KSA800ET450	KSA1000ET450
Compatible with	KSA500 to 1000	KSA500 to 1000	KSA500 to 1000	KSA500 to 1000
A in the line (mm)	5000	5000	5000	5000
Rating (A)	500	630	800	1000
Polarity	3L + N + PE	3L + N + PE	3L + N + PE	3L + N + PE

Characteristics				
Fire Barrier	No	No	No	No
Fire Barrier	-	-	-	-
Position				

Additional Characteristics				
IP	IP55	IP55	IP55	IP55
Color	White	White	White	White
Weight (kg)	54,5	58,2	69,2	89,5
Selling Unit	1	1	1	1
MOQ	1	1	1	1

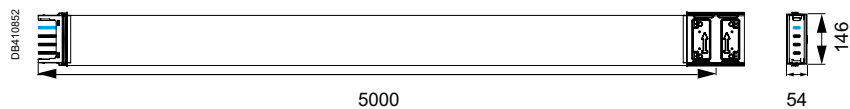

KSA100 to 400 ET •50

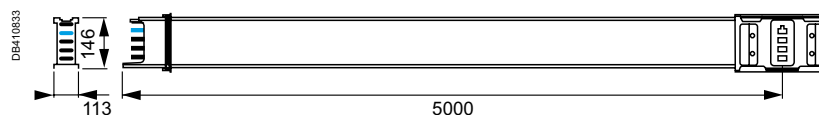

KSA500 to 1000 ET •50

Advanced offer

Straight lengths

Made-to-measure

DB410895  **For Transport (without Outlets)**
Horizontal mounting

KSA100 to 400 ET •A

DB410896  **For Transport (without Outlets)**
Horizontal mounting

KSA500 to 1000 ET •A

Cat. n°	KSA250ET43A	KSA400ET43A	KSA630ET43A	KSA1000ET43A
Compatible with	KSA100 to 250	KSA400	KSA500 to 1000	KSA500 to 1000
A in the line (mm)	500 to 1900	500 to 1900	500 to 1900	500 to 1900
Rating (A)	250	400	630	1000
Polarity	3L + N + PE	3L + N + PE	3L + N + PE	3L + N + PE

Characteristics				
Fire Barrier	No	No	No	No
Fire Barrier Position	-	-	-	-

Additional Characteristics				
IP	IP55	IP55	IP55	IP55
Color	White	White	White	White
Weight (kg)	8	10	30	32,2
Selling Unit	1	1	1	1
MOQ	1	1	1	1

A dimension can be adjusted in increments of 5 mm. See A minimum and maximum.

To order, indicate for example: KSA400ET43A, A = 710 mm

Made-to-measure - With 1 fire barrier

DB410897  **For Transport (without Outlets)**
Horizontal mounting

KSA100 to 400 ET •AF

DB410898  **For Transport (without Outlets)**
Horizontal mounting

KSA500 to 1000 ET •AF

Cat. n°	KSA250ET43AF	KSA400ET43AF	KSA630ET43AF	KSA1000ET43AF
Compatible with	KSA100 to 250	KSA400	KSA500 to 1000	KSA500 to 1000
A in the line (mm)	800 to 1900	800 to 1900	800 to 1900	800 to 1900
Rating (A)	250	400	630	1000
Polarity	3L + N + PE	3L + N + PE	3L + N + PE	3L + N + PE

Characteristics				
Fire Barrier	Yes	Yes	Yes	Yes
Fire Barrier Position	Minimum 400 mm from the edge	Minimum 400 mm from the edge	Minimum 400 mm from the edge	Minimum 400 mm from the edge

Additional Characteristics				
IP	IP55	IP55	IP55	IP55
Color	White	White	White	White
Weight (kg)	8,2	10	30	37
Selling Unit	1	1	1	1
MOQ	1	1	1	1

A dimension can be adjusted in increments of 5 mm. See A minimum and maximum.

Fire barrier position is adjustable in increments of 10 mm respecting the Xa and Ya minimum.

To order, indicate for example: KSA400ET43AF, A = 950 mm, Xa = 450, Ya = 500

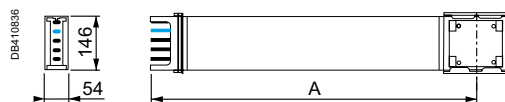

KSA100 to 400 ET •A

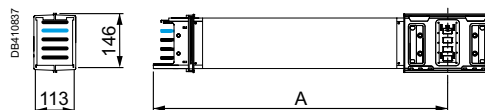

KSA500 to 1000 ET •A

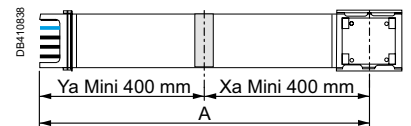

KSA100 to 400 ET •AF

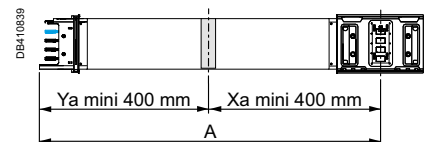

KSA500 to 1000 ET •AF

Advanced offer

Change direction elements

Elbows

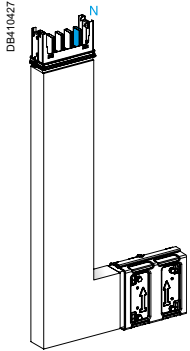

KSA100 to 400 DLE 41A

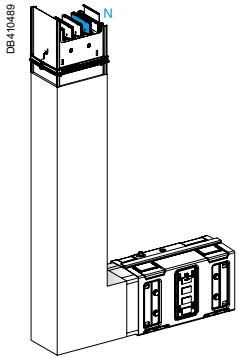

KSA500 to 1000 DLE 41A

To go Upward at 90° (Edgewise position)
Side A is fixed, Side B is made-to-measure

Cat. n°	KSA250DLE41A	KSA400DLE41A	KSA630DLE41A	KSA1000DLE41A
Compatible with	KSA100 to 250	KSA400	KSA500 to 1000	KSA500 to 1000
A in the line (mm)	500 to 1000	500 to 1000	580 to 1100	580 to 1100
Rating (A)	250	400	630	1000
Polarity	3L + N + PE	3L + N + PE	3L + N + PE	3L + N + PE

Dimensions				
A (mm)	250	250	290	290
B (mm)	250 to 750	250 to 750	290 to 800	290 to 800
C (mm)	-	-	-	-
D (mm)	-	-	-	-
Fire Barrier	No	No	No	No
Fire Barrier Position	-	-	-	-

Additional Characteristics				
IP	IP55	IP55	IP55	IP55
Color	White	White	White	White
Weight (kg)	-	-	-	-
Selling Unit	1	1	1	1
MOQ	1	1	1	1

A dimension is fixed. B dimension can be adjusted in increments of 5 mm.
See B minimum and maximum.

To order, indicate for example: KSA400DLE41A, B = 500

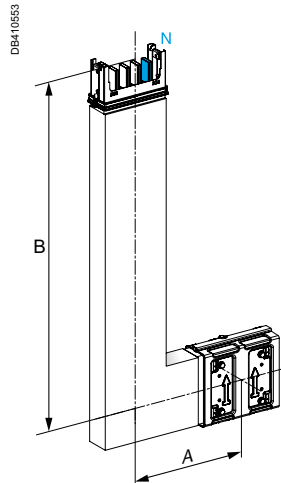

KSA100 to 400 DLE 41A

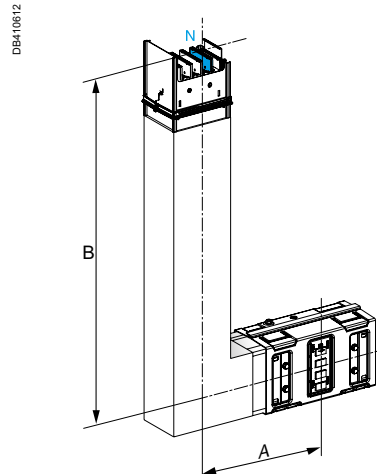

KSA500 to 1000 DLE 41A

Advanced offer

Change direction elements

Elbows

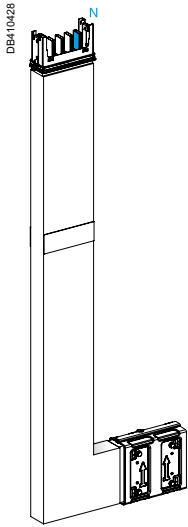

KSA100 to 400 DLE 41F

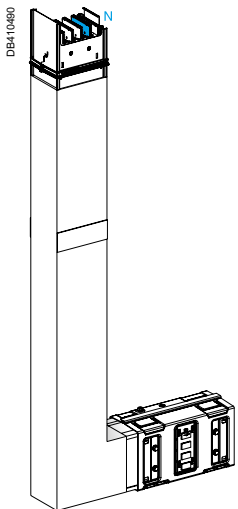

KSA500 to 1000 DLE 41F

To go Upward at 90° (Edgewise position)
Side A is fixed, Side B is made-to-measure including 1 Fire Barrier (FB)

Cat. n°	KSA250DLE41F	KSA400DLE41F	KSA630DLE41F	KSA1000DLE41F
Compatible with	KSA100 to 250	KSA400	KSA500 to 1000	KSA500 to 1000
A in the line (mm)	950 to 1450	950 to 1450	990 to 1500	990 to 1500
Rating (A)	250	400	630	1000
Polarity	3L + N + PE	3L + N + PE	3L + N + PE	3L + N + PE

Dimensions				
A (mm)	250	250	290	290
B (mm)	700 to 1200	700 to 1200	700 to 1200	700 to 1200
C (mm)	-	-	-	-
D (mm)	-	-	-	-
Fire Barrier	Yes	Yes	Yes	Yes
Fire Barrier Position	On side B	On side B	On side B	On side B

Additional Characteristics				
IP	IP55	IP55	IP55	IP55
Color	White	White	White	White
Weight (kg)	-	-	-	-
Selling Unit	1	1	1	1
MOQ	1	1	1	1

A dimension is fixed. B dimension can be adjusted in increments of 5 mm.
 See B minimum and maximum. Fire barrier position on side B is adjustable in increments of 10 mm respecting the Xb and Yb minimum.
 To order, indicate for example: KSA400DLE41F, B = 900, Xb = 500, Yb = 400

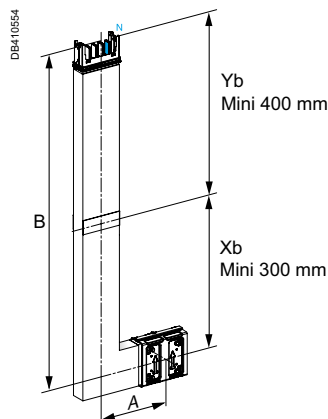

KSA100 to 400 DLE 41F

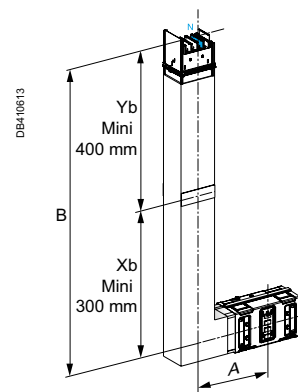

KSA500 to 1000 DLE 41F



Advanced offer

Change direction elements

Elbows

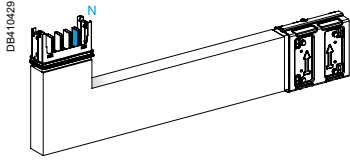

To go Upward at 90° (Edgewise position)
Side A is made-to-measure, Side B is fixed

Cat. n°	KSA250DLE42A	KSA400DLE42A	KSA630DLE42A	KSA1000DLE42A
Compatible with	KSA100 to 250	KSA400	KSA500 to 1000	KSA500 to 1000
A in the line (mm)	500 to 1000	500 to 1000	580 to 1100	580 to 1100

KSA100 to 400 DLE 42A

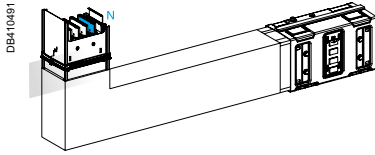

Rating (A)	250	400	630	1000
Polarity	3L + N + PE	3L + N + PE	3L + N + PE	3L + N + PE

KSA500 to 1000 DLE 42A

Dimensions				
A (mm)	250 to 750	250 to 750	290 to 800	290 to 800
B (mm)	250	250	290	290
C (mm)	-	-	-	-
D (mm)	-	-	-	-
Fire Barrier	No	No	No	No
Fire Barrier Position	-	-	-	-

Additional Characteristics				
IP	IP55	IP55	IP55	IP55
Color	White	White	White	White
Weight (kg)	-	-	-	-
Selling Unit	1	1	1	1
MOQ	1	1	1	1

A dimension can be adjusted in increments of 5 mm. See A minimum and maximum. B dimension is fixed.

To order, indicate for example: KSA400DLE42A, A = 500

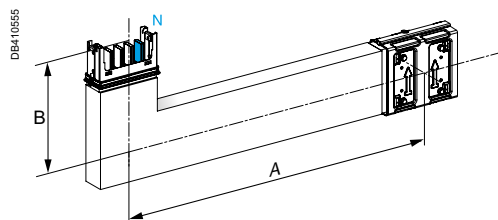

KSA100 to 400 DLE 42A

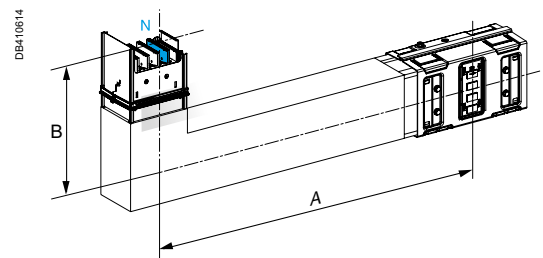

KSA500 to 1000 DLE 42A

Advanced offer

Change direction elements

Elbows

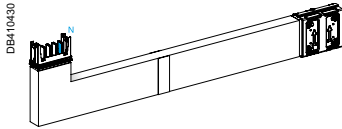

KSA100 to 400 DLE 42F

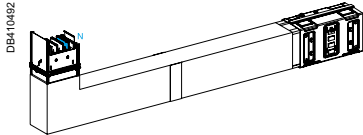

KSA500 to 1000 DLE 42F

To go Upward at 90° (Edgewise position)
Side A is made-to-measure including 1 Fire Barrier (FB), Side B is fixed

Cat. n°	KSA250DLE42F	KSA400DLE42F	KSA630DLE42F	KSA1000DLE42F
Compatible with	KSA100 to 250	KSA400	KSA500 to 1000	KSA500 to 1000
A in the line (mm)	950 to 1450	950 to 1450	990 to 1500	990 to 1500
Rating (A)	250	400	630	1000
Polarity	3L + N + PE	3L + N + PE	3L + N + PE	3L + N + PE

Dimensions				
A (mm)	700 to 1200	700 to 1200	700 to 1200	700 to 1200
B (mm)	250	250	290	290
C (mm)	-	-	-	-
D (mm)	-	-	-	-
Fire Barrier	Yes	Yes	Yes	Yes
Fire Barrier Position	On side A	On side A	On side A	On side A

Additional Characteristics				
IP	IP55	IP55	IP55	IP55
Color	White	White	White	White
Weight (kg)	-	-	-	-
Selling Unit	1	1	1	1
MOQ	1	1	1	1

A dimension can be adjusted in increments of 5 mm. See A minimum and maximum. Fire barrier position on side A is adjustable in increments of 10 mm respecting the Xb and Yb minimum. B dimension is fixed.

To order, indicate for example: KSA400DLE42F, A = 900, Xa = 500, Ya = 400

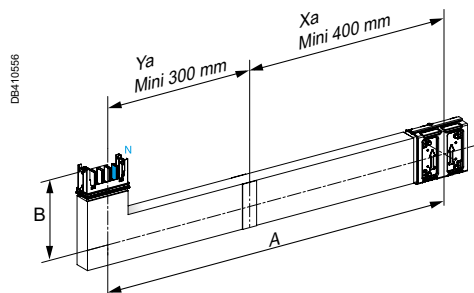

KSA100 to 400 DLE 42F

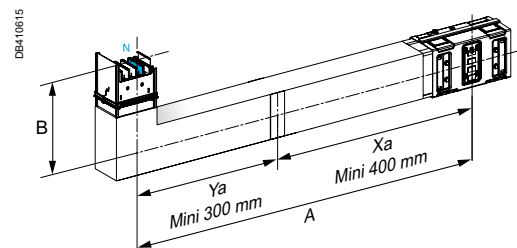

KSA500 to 1000 DLE 42F



Advanced offer

Change direction elements

Elbows

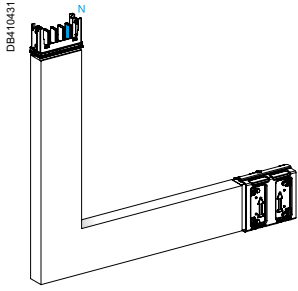

KSA100 to 400 DLE 43A

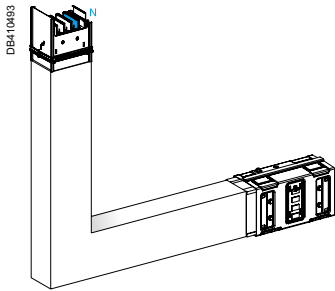

KSA500 to 1000 DLE 43A

To go Upward at 90° (Edgewise position)
Sides A and B are made-to-measure

Cat. n°	KSA250DLE43A	KSA400DLE43A	KSA630DLE43A	KSA1000DLE43A
Compatible with	KSA100 to 250	KSA400	KSA500 to 1000	KSA500 to 1000
A in the line (mm)	500 to 1500	500 to 1500	580 to 1600	580 to 1600
Rating (A)	250	400	630	1000
Polarity	3L + N + PE	3L + N + PE	3L + N + PE	3L + N + PE

Dimensions				
A (mm)	250 to 750	250 to 750	290 to 800	290 to 800
B (mm)	250 to 750	250 to 750	290 to 800	290 to 800
C (mm)	-	-	-	-
D (mm)	-	-	-	-
Fire Barrier	No	No	No	No
Fire Barrier Position	-	-	-	-

Additional Characteristics				
IP	IP55	IP55	IP55	IP55
Color	White	White	White	White
Weight (kg)	-	-	-	-
Selling Unit	1	1	1	1
MOQ	1	1	1	1

A and B dimensions can be adjusted in increments of 5 mm. See A and B minimum and maximum.

To order, indicate for example: KSA400DLE43A, A = 500, B = 500

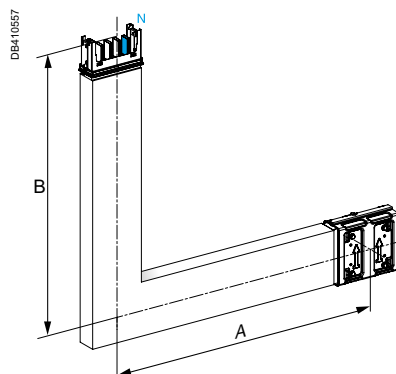

KSA100 to 400 DLE 43A

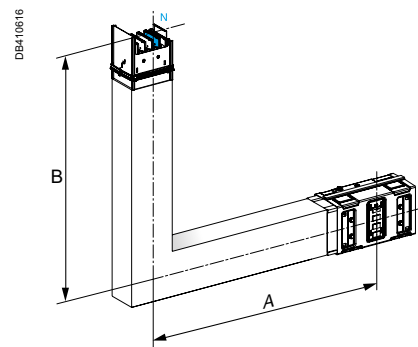

KSA500 to 1000 DLE 43A

Advanced offer

Change direction elements

Elbows

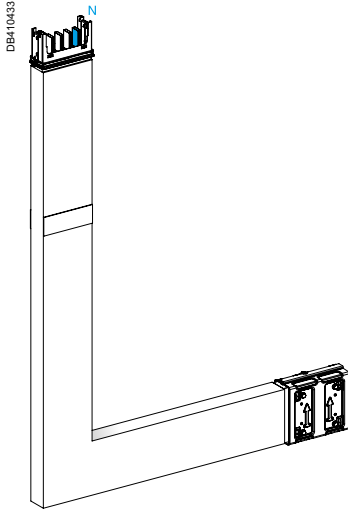

KSA100 to 400 DLE 43F

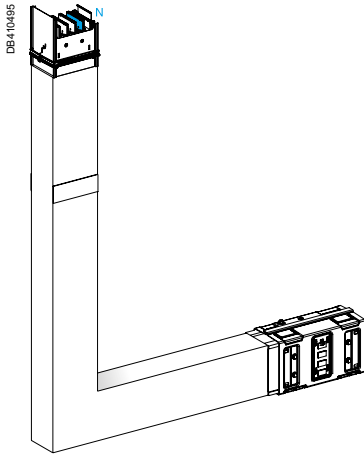

KSA500 to 1000 DLE 43F

To go Upward at 90° (Edgewise position)
Sides A and B are made-to-measure including 1 Fire Barrier (FB) on 1 side

Cat. n°	KSA250DLE43F	KSA400DLE43F	KSA630DLE43F	KSA1000DLE43F
Compatible with	KSA100 to 250	KSA400	KSA500 to 1000	KSA500 to 1000
A in the line (mm)	950 to 1950	950 to 1950	990 to 2000	990 to 2000
Rating (A)	250	400	630	1000
Polarity	3L + N + PE	3L + N + PE	3L + N + PE	3L + N + PE

Dimensions

A (mm)	(250 to 750) or (700 to 1200) if FB	(250 to 750) or (700 to 1200) if FB	(290 to 800) or (700 to 1200) if FB	(290 to 800) or (700 to 1200) if FB
B (mm)	(250 to 750) or (700 to 1200) if FB	(250 to 750) or (700 to 1200) if FB	(290 to 800) or (700 to 1200) if FB	(290 to 800) or (700 to 1200) if FB
C (mm)	-	-	-	-
D (mm)	-	-	-	-
Fire Barrier	Yes	Yes	Yes	Yes
Fire Barrier Position	Either on side A or B	Either on side A or B	Either on side A or B	Either on side A or B

Additional Characteristics

IP	IP55	IP55	IP55	IP55
Color	White	White	White	White
Weight (kg)	-	-	-	-
Selling Unit	1	1	1	1
MOQ	1	1	1	1

A and B dimensions can be adjusted in increments of 5 mm. See A and B minimum and maximum. One Fire barrier can be positioned on side A or on side B. Fire barrier position is adjustable in increments of 10 mm respecting the Xa and Ya or Xb and Yb minimum
 To order, indicate for example: KSA400DLE43F, A = 500, B = 900, Xb = 450, Yb = 450

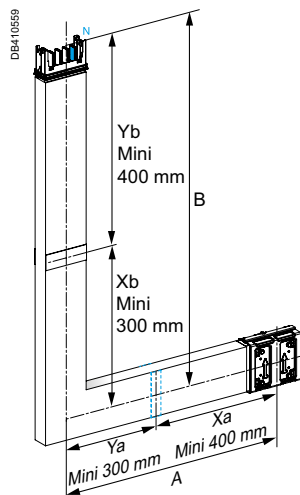

KSA100 to 400 DLE 43F

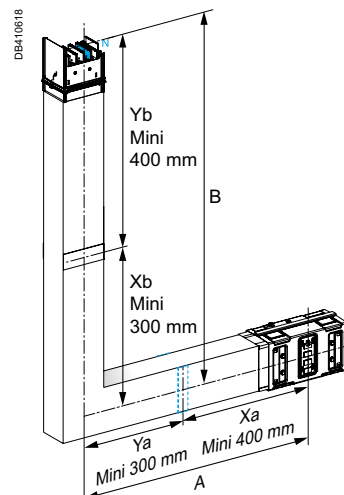

KSA500 to 1000 DLE 43F

Advanced offer

Change direction elements

Elbows

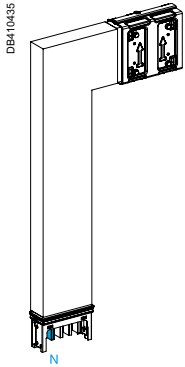

KSA100 to 400 DLF 41A

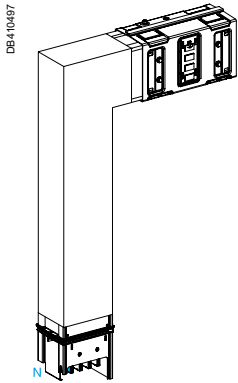

KSA500 to 1000 DLF 41A

To go Downward at 90° (Edgewise position)
Side A is fixed, Side B is made-to-measure

Cat. n°	KSA250DLF41A	KSA400DLF41A	KSA630DLF41A	KSA1000DLF41A
Compatible with	KSA100 to 250	KSA400	KSA500 to 1000	KSA500 to 1000
A in the line (mm)	500 to 1000	500 to 1000	600 to 1100	600 to 1100
Rating (A)	250	400	630	1000
Polarity	3L + N + PE	3L + N + PE	3L + N + PE	3L + N + PE

Dimensions				
A (mm)	250	250	290	290
B (mm)	250 to 750	250 to 750	300 to 800	300 to 800
C (mm)	-	-	-	-
D (mm)	-	-	-	-
Fire Barrier	No	No	No	No
Fire Barrier Position	-	-	-	-

Additional Characteristics				
IP	IP55	IP55	IP55	IP55
Color	White	White	White	White
Weight (kg)	-	-	-	-
Selling Unit	1	1	1	1
MOQ	1	1	1	1

A dimension is fixed. B dimension can be adjusted in increments of 5 mm.
See B minimum and maximum.

To order, indicate for example: KSA400DLF41A, B = 500

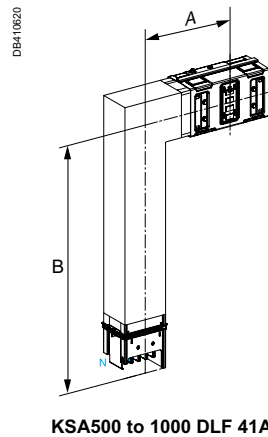
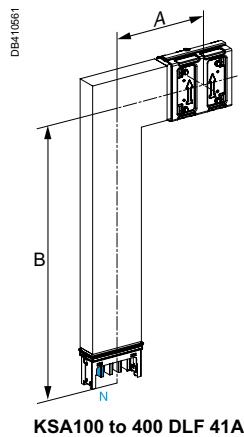

Advanced offer

Change direction elements

Elbows

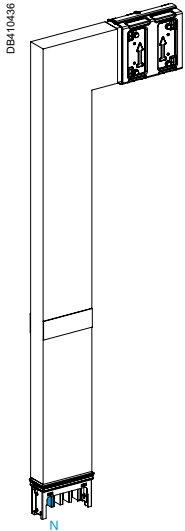

KSA100 to 400 DLF 41F

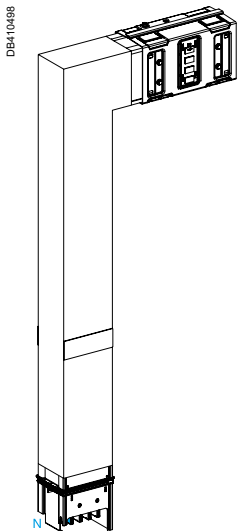

KSA500 to 1000 DLF 41F

To go Downward at 90° (Edgewise position)
Side A is fixed, Side B is made-to-measure including 1 Fire Barrier (FB)

Cat. n°	KSA250DLF41F	KSA400DLF41F	KSA630DLF41F	KSA1000DLF41F
Compatible with	KSA100 to 250	KSA400	KSA500 to 1000	KSA500 to 1000
A in the line (mm)	950 to 1450	950 to 1450	990 to 1500	990 to 1500
Rating (A)	250	400	630	1000
Polarity	3L + N + PE	3L + N + PE	3L + N + PE	3L + N + PE

Dimensions

A (mm)	250	250	290	290
B (mm)	700 to 1200	700 to 1200	700 to 1200	700 to 1200
C (mm)	-	-	-	-
D (mm)	-	-	-	-
Fire Barrier	Yes	Yes	Yes	Yes
Fire Barrier Position	On side B	On side B	On side B	On side B

Additional Characteristics

IP	IP55	IP55	IP55	IP55
Color	White	White	White	White
Weight (kg)	-	-	-	-
Selling Unit	1	1	1	1
MOQ	1	1	1	1

A dimension is fixed. B dimension can be adjusted in increments of 5 mm.
 See B minimum and maximum. Fire barrier position on side B is adjustable in increments of 10 mm respecting the Xb and Yb minimum.
 To order, indicate for example: KSA400DLF41F, B = 900, Xb = 500, Yb = 400

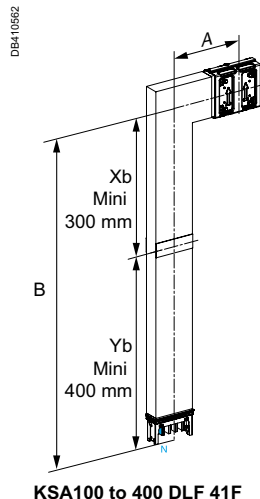

KSA100 to 400 DLF 41F

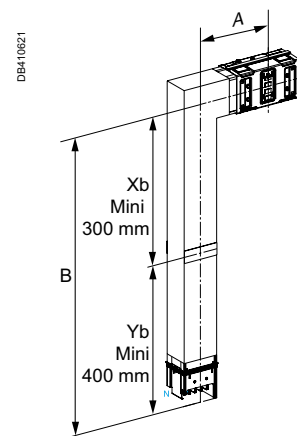

KSA500 to 1000 DLF 41F

Advanced offer

Change direction elements

Elbows

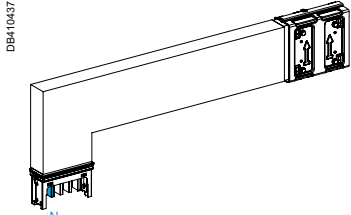

KSA100 to 400 DLF 42A

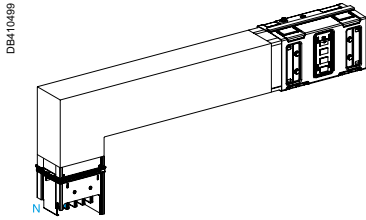

KSA500 to 1000 DLF 42A

To go Downward at 90° (Edgewise position)
Side A is made-to-measure, Side B is fixed

Cat. n°	KSA250DLF42A	KSA400DLF42A	KSA630DLF42A	KSA1000DLF42A
Compatible with	KSA100 to 250	KSA400	KSA500 to 1000	KSA500 to 1000
A in the line (mm)	500 to 1000	500 to 1000	580 to 1100	580 to 1100
Rating (A)	250	400	630	1000
Polarity	3L + N + PE	3L + N + PE	3L + N + PE	3L + N + PE

Dimensions				
A (mm)	250 to 750	250 to 750	290 to 800	290 to 800
B (mm)	250	250	290	290
C (mm)	-	-	-	-
D (mm)	-	-	-	-
Fire Barrier	No	No	No	No
Fire Barrier Position	-	-	-	-

Additional Characteristics				
IP	IP55	IP55	IP55	IP55
Color	White	White	White	White
Weight (kg)	-	-	-	-
Selling Unit	1	1	1	1
MOQ	1	1	1	1

A dimension can be adjusted in increments of 5 mm. See A minimum and maximum. B dimension is fixed.

To order, indicate for example: KSA400DLF42A, A = 500

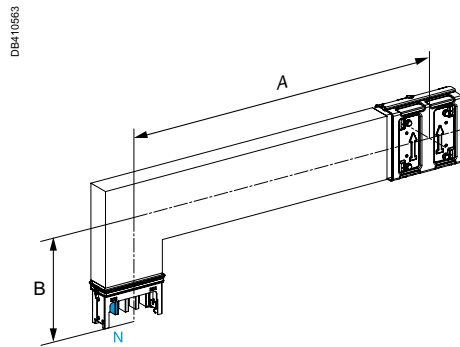

KSA100 to 400 DLF 42A

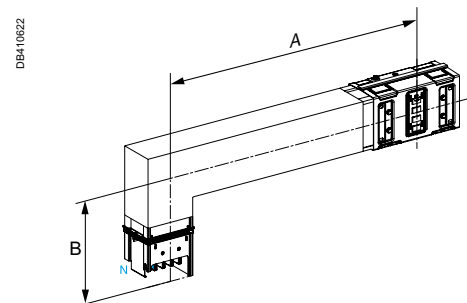

KSA500 to 1000 DLF 42A

Advanced offer

Change direction elements

Elbows

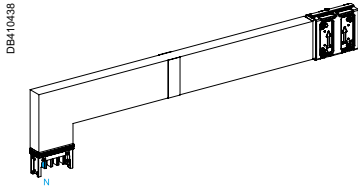

KSA100 to 400 DLF 42F

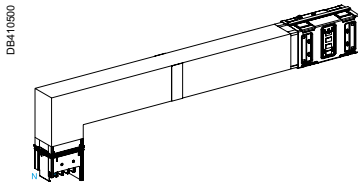

KSA500 to 1000 DLF 42F

To go Downward at 90° (Edgewise position)
Side A is made-to-measure including 1 Fire Barrier (FB), Side B is fixed

Cat. n°	KSA250DLF42F	KSA400DLF42F	KSA630DLF42F	KSA1000DLF42F
Compatible with	KSA100 to 250	KSA400	KSA500 to 1000	KSA500 to 1000
A in the line (mm)	950 to 1450	950 to 1450	990 to 1500	990 to 1500
Rating (A)	250	400	630	1000
Polarity	3L + N + PE	3L + N + PE	3L + N + PE	3L + N + PE

Dimensions				
A (mm)	700 to 1200	700 to 1200	700 to 1200	700 to 1200
B (mm)	250	250	290	290
C (mm)	-	-	-	-
D (mm)	-	-	-	-
Fire Barrier	Yes	Yes	Yes	Yes
Fire Barrier Position	On side A	On side A	On side A	On side A

Additional Characteristics				
IP	IP55	IP55	IP55	IP55
Color	White	White	White	White
Weight (kg)	-	-	-	-
Selling Unit	1	1	1	1
MOQ	1	1	1	1

A dimension can be adjusted in increments of 5 mm. See A minimum and maximum. Fire barrier position on side A is adjustable in increments of 10 mm respecting the Xb and Yb minimum. B dimension is fixed.

To order, indicate for example: KSA400DLF42F, A = 900, Xa = 500, Ya = 400

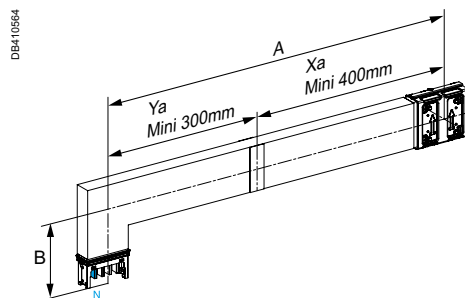

KSA100 to 400 DLF 42F

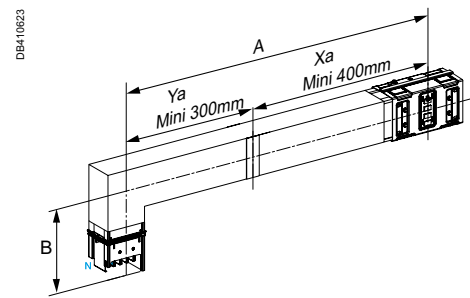

KSA500 to 1000 DLF 42F



Advanced offer

Change direction elements

Elbows

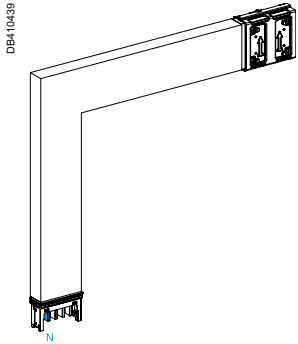

To go Downward at 90° (Edgewise position)
Sides A and B are made-to-measure

Cat. n°	KSA250DLF43A	KSA400DLF43A	KSA630DLF43A	KSA1000DLF43A
Compatible with	KSA100 to 250	KSA400	KSA500 to 1000	KSA500 to 1000
A in the line (mm)	500 to 1500	500 to 1500	580 to 1600	580 to 1600
Rating (A)	250	400	630	1000
Polarity	3L + N + PE	3L + N + PE	3L + N + PE	3L + N + PE

KSA100 to 400 DLF 43A

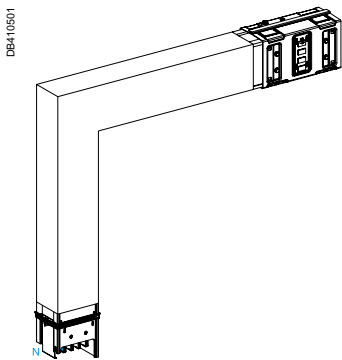

Dimensions				
A (mm)	250 to 750	250 to 750	290 to 800	290 to 800
B (mm)	250 to 750	250 to 750	290 to 800	290 to 800
C (mm)	-	-	-	-
D (mm)	-	-	-	-
Fire Barrier	No	No	No	No
Fire Barrier Position	-	-	-	-

KSA500 to 1000 DLF 43A

Additional Characteristics				
IP	IP55	IP55	IP55	IP55
Color	White	White	White	White
Weight (kg)	-	-	-	-
Selling Unit	1	1	1	1
MOQ	1	1	1	1

A and B dimensions can be adjusted in increments of 5 mm. See A and B minimum and maximum.

To order, indicate for example: KSA400DLF43A, A = 500, B = 500

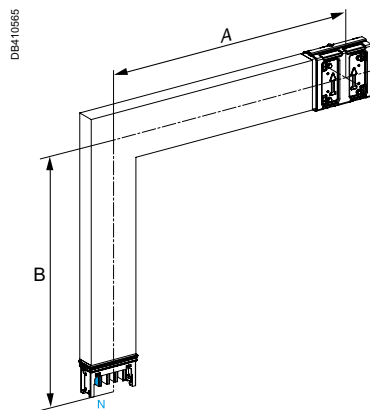

KSA100 to 400 DLF 43A

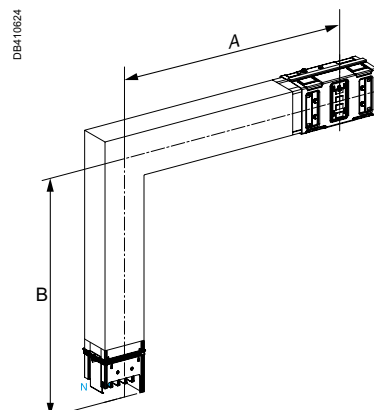

KSA500 to 1000 DLF 43A

Advanced offer

Change direction elements

Elbows

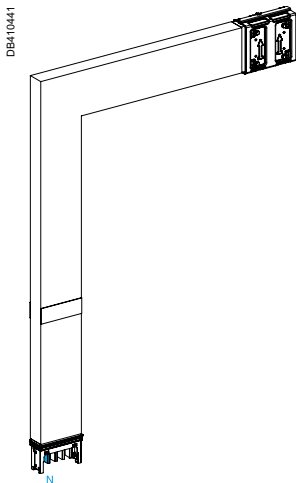

KSA100 to 400 DLF 43F

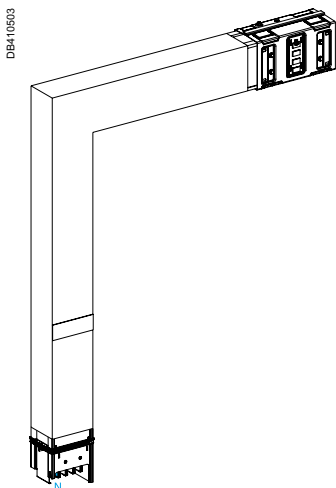

KSA500 to 1000 DLF 43F

To go Downward at 90° (Edgewise position)
Sides A and B are made-to-measure including 1 Fire Barrier (FB) on 1 side

Cat. n°	KSA250DLF43F	KSA400DLF43F	KSA630DLF43F	KSA1000DLF43F
Compatible with	KSA100 to 250	KSA400	KSA500 to 1000	KSA500 to 1000
A in the line (mm)	950 to 1950	950 to 1950	990 to 2000	990 to 2000
Rating (A)	250	400	630	1000
Polarity	3L + N + PE	3L + N + PE	3L + N + PE	3L + N + PE

Dimensions				
A (mm)	(250 to 750) or (700 to 1200) if FB	(250 to 750) or (700 to 1200) if FB	(290 to 800) or (700 to 1200) if FB	(290 to 800) or (700 to 1200) if FB
B (mm)	(250 to 750) or (700 to 1200) if FB	(250 to 750) or (700 to 1200) if FB	(290 to 800) or (700 to 1200) if FB	(290 to 800) or (700 to 1200) if FB
C (mm)	-	-	-	-
D (mm)	-	-	-	-
Fire Barrier	Yes	Yes	Yes	Yes
Fire Barrier Position	Either on side A or B	Either on side A or B	Either on side A or B	Either on side A or B

Additional Characteristics				
IP	IP55	IP55	IP55	IP55
Color	White	White	White	White
Weight (kg)	-	-	-	-
Selling Unit	1	1	1	1
MOQ	1	1	1	1

A and B dimensions can be adjusted in increments of 5 mm. See A and B minimum and maximum. One Fire barrier can be positioned on side A or on side B. Fire barrier position is adjustable in increments of 10 mm respecting the Xa and Ya or Xb and Yb minimum
 To order, indicate for example: KSA400DLF43F, A = 500, B = 900, Xb = 450, Yb = 450

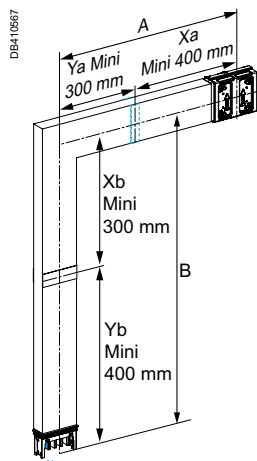

KSA100 to 400 DLF 43F

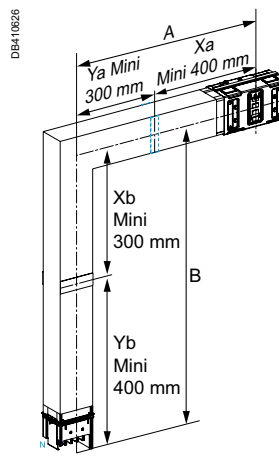

KSA500 to 1000 DLF 43F



Advanced offer

Change direction elements

Elbows

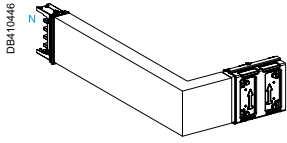

KSA100 to 400 DLR 41A

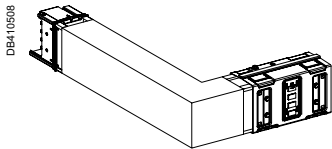

KSA500 to 1000 DLR 41A

To turn Right at 90° (Edgewise position)
Side A is fixed, Side B is made-to-measure

Cat. n°	KSA250DLR41A	KSA400DLR41A	KSA630DLR41A	KSA1000DLR41A
Compatible with	KSA100 to 250	KSA400	KSA500 to 1000	KSA500 to 1000
A in the line (mm)	500 to 1000	500 to 1000	600 to 1100	600 to 1100
Rating (A)	250	400	630	1000
Polarity	3L + N + PE	3L + N + PE	3L + N + PE	3L + N + PE

Dimensions				
A (mm)	200	200	290	290
B (mm)	200 to 750	200 to 750	290 to 800	290 to 800
C (mm)	-	-	-	-
D (mm)	-	-	-	-
Fire Barrier	No	No	No	No
Fire Barrier Position	-	-	-	-

Additional Characteristics				
IP	IP55	IP55	IP55	IP55
Color	White	White	White	White
Weight (kg)	-	-	-	-
Selling Unit	1	1	1	1
MOQ	1	1	1	1

A dimension is fixed. B dimension can be adjusted in increments of 5 mm.
See B minimum and maximum.

To order, indicate for example: KSA400DLR41A, B = 500

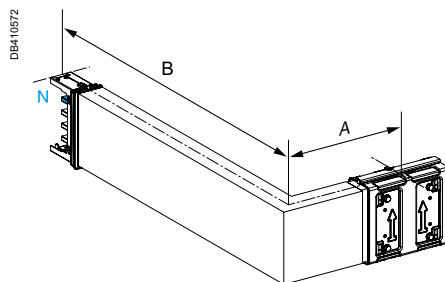

KSA100 to 400 DLR 41A

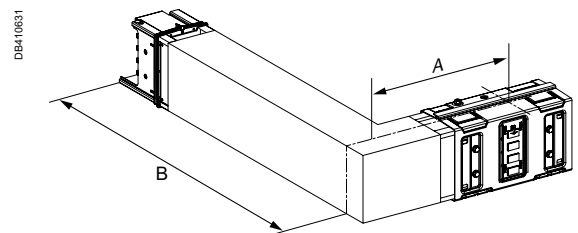

KSA500 to 1000 DLR 41A

Advanced offer

Change direction elements

Elbows

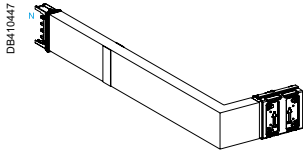

KSA100 to 400 DLR 41F

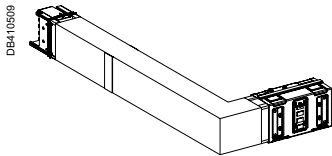

KSA500 to 1000 DLR 41F

To turn Right at 90° (Edgewise position)
Side A is fixed, Side B is made-to-measure including 1 Fire Barrier (FB)

Cat. n°	KSA250DLR41F	KSA400DLR41F	KSA630DLR41F	KSA1000DLR41F
Compatible with	KSA100 to 250	KSA400	KSA500 to 1000	KSA500 to 1000
A in the line (mm)	900 to 1450	900 to 1450	990 to 1500	990 to 1500
Rating (A)	250	400	630	1000
Polarity	3L + N + PE	3L + N + PE	3L + N + PE	3L + N + PE

Dimensions				
A (mm)	200	200	290	290
B (mm)	700 to 1200	700 to 1200	700 to 1200	700 to 1200
C (mm)	-	-	-	-
D (mm)	-	-	-	-
Fire Barrier	Yes	Yes	Yes	Yes
Fire Barrier Position	On side B	On side B	On side B	On side B

Additional Characteristics				
IP	IP55	IP55	IP55	IP55
Color	White	White	White	White
Weight (kg)	-	-	-	-
Selling Unit	1	1	1	1
MOQ	1	1	1	1

A dimension is fixed. B dimension can be adjusted in increments of 5 mm.
See B minimum and maximum. Fire barrier position on side B is adjustable in increments of 10 mm respecting the Xb and Yb minimum.
To order, indicate for example: KSA400DLR41F, B = 900, Xb = 500, Yb = 400

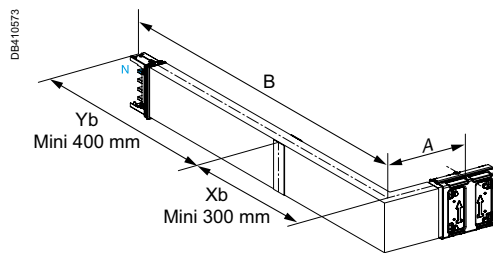

KSA100 to 400 DLR 41F

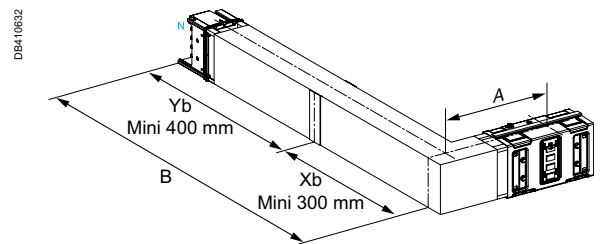

KSA500 to 1000 DLR 41F



Advanced offer

Change direction elements

Elbows

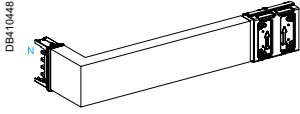

KSA100 to 400 DLR 42A

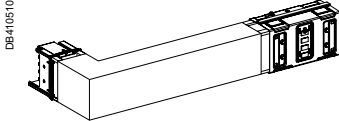

KSA500 to 1000 DLR 42A

To turn Right at 90° (Edgewise position)
Side A is made-to-measure, Side B is fixed

Cat. n°	KSA250DLR42A	KSA400DLR42A	KSA630DLR42A	KSA1000DLR42A
Compatible with	KSA100 to 250	KSA400	KSA500 to 1000	KSA500 to 1000
A in the line (mm)	400 to 1000	400 to 1000	580 to 1100	580 to 1100
Rating (A)	250	400	630	1000
Polarity	3L + N + PE	3L + N + PE	3L + N + PE	3L + N + PE

Dimensions				
A (mm)	200 to 750	200 to 750	290 to 800	290 to 800
B (mm)	200	200	290	290
C (mm)	-	-	-	-
D (mm)	-	-	-	-
Fire Barrier	No	No	No	No
Fire Barrier Position	-	-	-	-

Additional Characteristics				
IP	IP55	IP55	IP55	IP55
Color	White	White	White	White
Weight (kg)	-	-	-	-
Selling Unit	1	1	1	1
MOQ	1	1	1	1

A dimension can be adjusted in increments of 5 mm. See A minimum and maximum. B dimension is fixed.

To order, indicate for example: KSA400DLR42A, A = 500

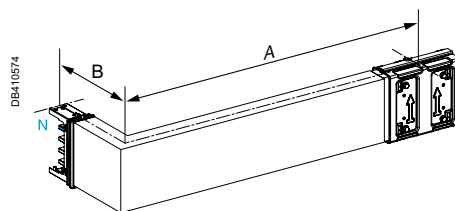

KSA250DLR42A

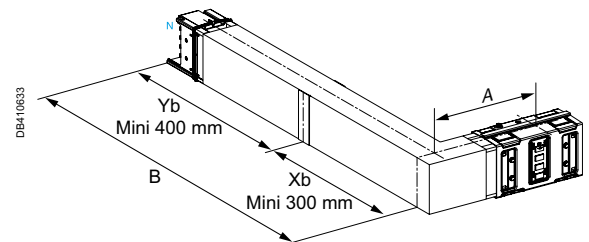

KSA500 to 1000 DLR 42A

Advanced offer

Change direction elements

Elbows

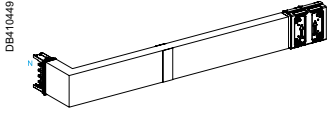

KSA100 to 400 DLR 42F

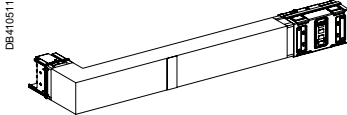

KSA500 to 1000 DLR 42F

To turn Right at 90° (Edgewise position)
Side A is made-to-measure including 1 Fire Barrier (FB), Side B is fixed

Cat. n°	KSA250DLR42F	KSA400DLR42F	KSA630DLR42F	KSA1000DLR42F
Compatible with	KSA100 to 250	KSA400	KSA500 to 1000	KSA500 to 1000
A in the line (mm)	900 to 1450	900 to 1450	990 to 1500	990 to 1500
Rating (A)	250	400	630	1000
Polarity	3L + N + PE	3L + N + PE	3L + N + PE	3L + N + PE

Dimensions				
A (mm)	700 to 1200	700 to 1200	700 to 1200	700 to 1200
B (mm)	200	200	290	290
C (mm)	-	-	-	-
D (mm)	-	-	-	-
Fire Barrier	Yes	Yes	Yes	Yes
Fire Barrier Position	On side A	On side A	On side A	On side A

Additional Characteristics				
IP	IP55	IP55	IP55	IP55
Color	White	White	White	White
Weight (kg)	-	-	-	-
Selling Unit	1	1	1	1
MOQ	1	1	1	1

A dimension can be adjusted in increments of 5 mm. See A minimum and maximum. Fire barrier position on side A is adjustable in increments of 10 mm respecting the Xb and Yb minimum. B dimension is fixed.

To order, indicate for example: KSA400DLR42F, A = 900, Xa = 500, Ya = 400

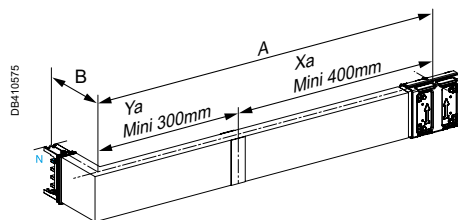

KSA100 to 400 DLR 42F

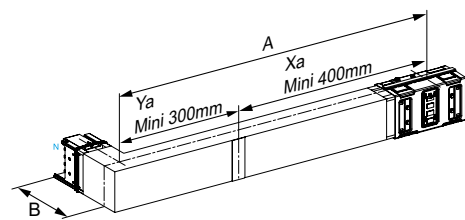

KSA500 to 1000 DLR 42F



Advanced offer

Change direction elements

Elbows

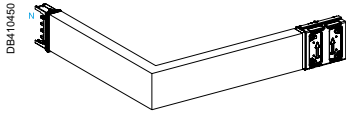

KSA100 to 400 DLR 43A

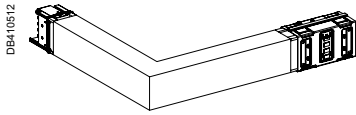

KSA500 to 1000 DLR 43A

To turn Right at 90° (Edgewise position)
Sides A and B are made-to-measure

Cat. n°	KSA250DLR43A	KSA400DLR43A	KSA630DLR43A	KSA1000DLR43A
Compatible with	KSA100 to 250	KSA400	KSA500 to 1000	KSA500 to 1000
A in the line (mm)	400 to 1500	400 to 1500	580 to 1600	580 to 1600
Rating (A)	250	400	630	1000
Polarity	3L + N + PE	3L + N + PE	3L + N + PE	3L + N + PE

Dimensions				
A (mm)	200 to 750	200 to 750	290 to 800	290 to 800
B (mm)	200 to 750	200 to 750	290 to 800	290 to 800
C (mm)	-	-	-	-
D (mm)	-	-	-	-
Fire Barrier	No	No	No	No
Fire Barrier Position	-	-	-	-

Additional Characteristics				
IP	IP55	IP55	IP55	IP55
Color	White	White	White	White
Weight (kg)	-	-	-	-
Selling Unit	1	1	1	1
MOQ	1	1	1	1

A and B dimensions can be adjusted in increments of 5 mm. See A and B minimum and maximum.

To order, indicate for example: KSA400DLR43A, A = 500, B = 500

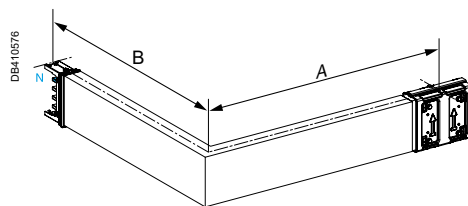

KSA100 to 400 DLR 43A

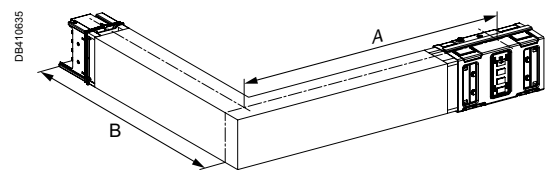

KSA500 to 1000 DLR 43A

Advanced offer

Change direction elements

Elbows

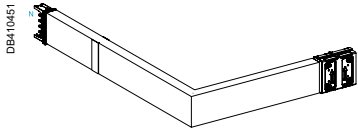

KSA100 to 400 DLR 43F

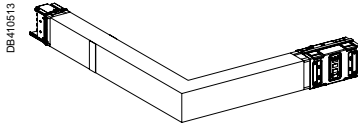

KSA500 to 1000 DLR 43F

To turn Right at 90° (Edgewise position)
Sides A and B are made-to-measure including 1 Fire Barrier (FB) on 1 side

Cat. n°	KSA250DLR43F	KSA400DLR43F	KSA630DLR43F	KSA1000DLR43F
Compatible with	KSA100 to 250	KSA400	KSA500 to 1000	KSA500 to 1000
A in the line (mm)	900 to 1950	900 to 1950	990 to 2000	990 to 2000
Rating (A)	250	400	630	1000
Polarity	3L + N + PE	3L + N + PE	3L + N + PE	3L + N + PE

Dimensions

A (mm)	(200 to 750) or (700 to 1200) if FB	(200 to 750) or (700 to 1200) if FB	(290 to 800) or (700 to 1200) if FB	(290 to 800) or (700 to 1200) if FB
B (mm)	(200 to 750) or (700 to 1200) if FB	(200 to 750) or (700 to 1200) if FB	(290 to 800) or (700 to 1200) if FB	(290 to 800) or (700 to 1200) if FB
C (mm)	-	-	-	-
D (mm)	-	-	-	-
Fire Barrier	Yes	Yes	Yes	Yes
Fire Barrier Position	Either on side A or B	Either on side A or B	Either on side A or B	Either on side A or B

Additional Characteristics

IP	IP55	IP55	IP55	IP55
Color	White	White	White	White
Weight (kg)	-	-	-	-
Selling Unit	1	1	1	1
MOQ	1	1	1	1

A and B dimensions can be adjusted in increments of 5 mm. See A and B minimum and maximum. One Fire barrier can be positioned on side A or on side B. Fire barrier position is adjustable in increments of 10 mm respecting the Xa and Ya or Xb and Yb minimum
To order, indicate for example: KSA400DLR43F, A = 500, B = 900, Xb = 450, Yb = 450

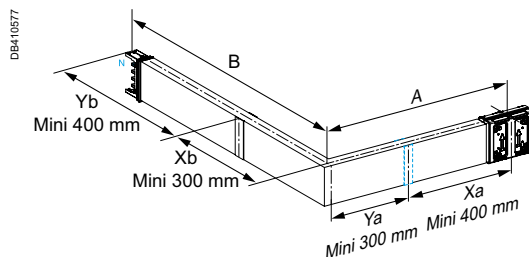

KSA100 to 400 DLR 43F

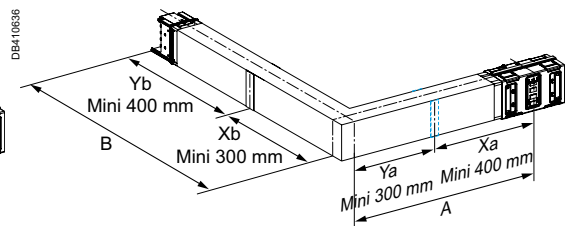

KSA500 to 1000 DLR 43F

E

Advanced offer

Change direction elements

Elbows

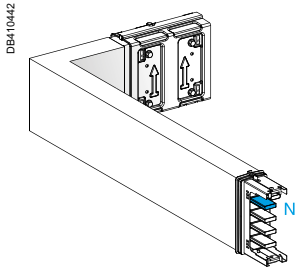

To turn Left at 90° (Edgewise position)
Side A is fixed, Side B is made-to-measure

Cat. n°	KSA250DLL41A	KSA400DLL41A	KSA630DLL41A	KSA1000DLL41A
Compatible with	KSA100 to 250	KSA400	KSA500 to 1000	KSA500 to 1000
A in the line (mm)	400 to 1000	400 to 1000	580 to 1100	580 to 1100
Rating (A)	250	400	630	1000
Polarity	3L + N + PE	3L + N + PE	3L + N + PE	3L + N + PE

KSA100 to 400 DLL 41A

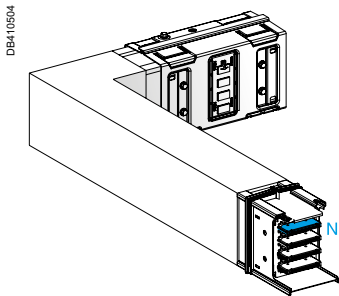

Dimensions				
A (mm)	200	200	290	290
B (mm)	200 to 750	200 to 750	290 to 800	290 to 800
C (mm)	-	-	-	-
D (mm)	-	-	-	-
Fire Barrier	No	No	No	No
Fire Barrier Position	-	-	-	-

KSA500 to 1000 DLL 41A

Additional Characteristics				
IP	IP55	IP55	IP55	IP55
Color	White	White	White	White
Weight (kg)	-	-	-	-
Selling Unit	1	1	1	1
MOQ	1	1	1	1

A dimension is fixed. B dimension can be adjusted in increments of 5 mm.
 See B minimum and maximum.

To order, indicate for example: KSA400DLL41A, B = 500

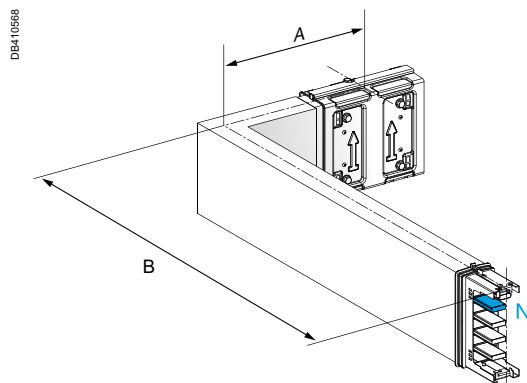

KSA100 to 400 DLL 41A

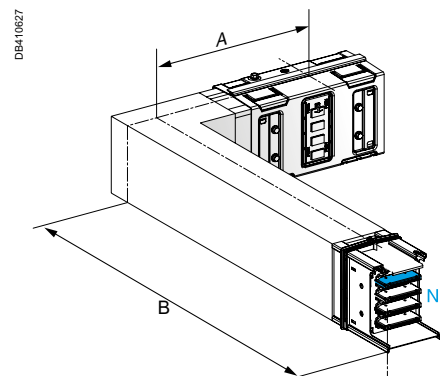

KSA500 to 1000 DLL 41A

Advanced offer

Change direction elements

Elbows

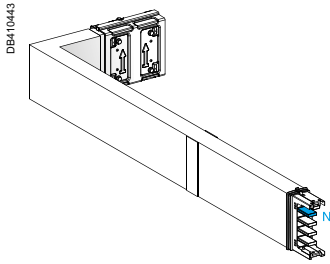

To turn Left at 90° (Edgewise position)
Side A is fixed, Side B is made-to-measure including 1 Fire Barrier (FB)

Cat. n°	KSA250DLL41F	KSA400DLL41F	KSA630DLL41F	KSA1000DLL41F
Compatible with	KSA100 to 250	KSA400	KSA500 to 1000	KSA500 to 1000
A in the line (mm)	900 to 1450	900 to 1450	990 to 1500	990 to 1500
Rating (A)	250	400	630	1000
Polarity	3L + N + PE	3L + N + PE	3L + N + PE	3L + N + PE

KSA100 to 400 DLL 41F

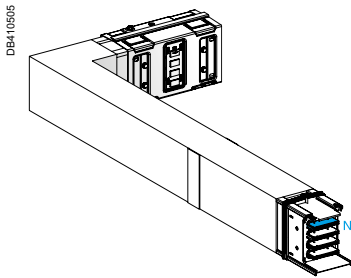

KSA500 to 1000 DLL 41F

Dimensions				
A (mm)	200	200	290	290
B (mm)	700 to 1200	700 to 1200	700 to 1200	700 to 1200
C (mm)	-	-	-	-
D (mm)	-	-	-	-
Fire Barrier	Yes	Yes	Yes	Yes
Fire Barrier Position	On side B	On side B	On side B	On side B

Additional Characteristics				
IP	IP55	IP55	IP55	IP55
Color	White	White	White	White
Weight (kg)	-	-	-	-
Selling Unit	1	1	1	1
MOQ	1	1	1	1

A dimension is fixed. B dimension can be adjusted in increments of 5 mm.
 See B minimum and maximum. Fire barrier position on side B is adjustable in increments of 10 mm respecting the Xb and Yb minimum.
 To order, indicate for example: KSA400DLL41F, B = 900, Xb = 500, Yb = 400

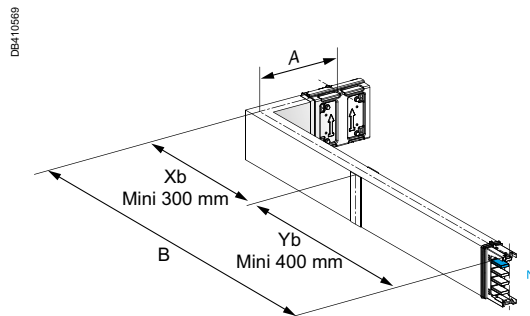

KSA100 to 400 DLL 41F

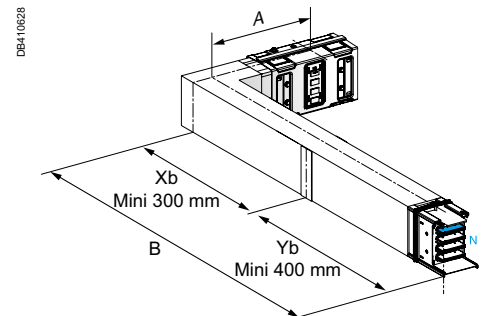

KSA500 to 1000 DLL 41F

Advanced offer

Change direction elements

Elbows

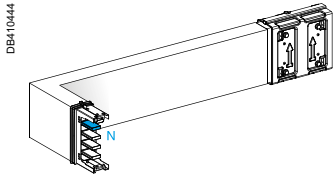

KSA100 to 400 DLL 42A

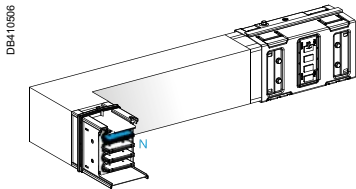

KSA500 to 1000 DLL 42A

**To turn Left at 90° (Edgewise position)
Side A is made-to-measure, Side B is fixed**

Cat. n°	KSA250DLL42A	KSA400DLL42A	KSA630DLL42A	KSA1000DLL42A
Compatible with	KSA100 to 250	KSA400	KSA500 to 1000	KSA500 to 1000
A in the line (mm)	400 to 1000	400 to 1000	580 to 1100	580 to 1100
Rating (A)	250	400	630	1000
Polarity	3L + N + PE	3L + N + PE	3L + N + PE	3L + N + PE

Dimensions				
A (mm)	200 to 750	200 to 750	290 to 800	290 to 800
B (mm)	200	200	290	290
C (mm)	-	-	-	-
D (mm)	-	-	-	-
Fire Barrier	No	No	No	No
Fire Barrier Position	-	-	-	-

Additional Characteristics				
IP	IP55	IP55	IP55	IP55
Color	White	White	White	White
Weight (kg)	-	-	-	-
Selling Unit	1	1	1	1
MOQ	1	1	1	1

A dimension can be adjusted in increments of 5 mm. See A minimum and maximum. B dimension is fixed.

To order, indicate for example: KSA400DLL42A, A = 500

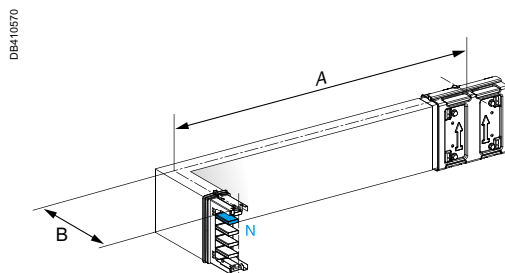

KSA100 to 400 DLL 42A

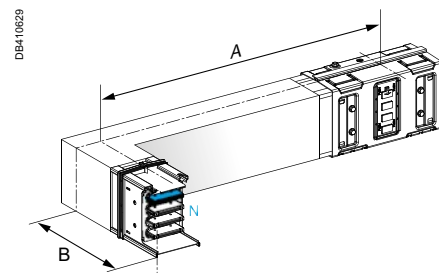

KSA500 to 1000 DLL 42A

Advanced offer

Change direction elements

Elbows

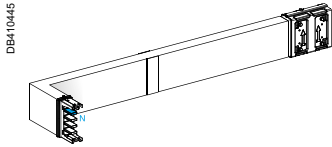

KSA100 to 400 DLL 42F

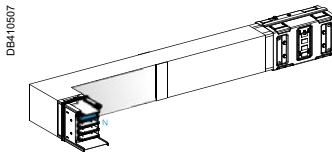

KSA500 to 1000 DLL 42F

To turn Left at 90° (Edgewise position)
Side A is made-to-measure including 1 Fire Barrier (FB), Side B is fixed

Cat. n°	KSA250DLL42F	KSA400DLL42F	KSA630DLL42F	KSA1000DLL42F
Compatible with	KSA100 to 250	KSA400	KSA500 to 1000	KSA500 to 1000
A in the line (mm)	900 to 1450	900 to 1450	990 to 1500	990 to 1500
Rating (A)	250	400	630	1000
Polarity	3L + N + PE	3L + N + PE	3L + N + PE	3L + N + PE

Dimensions				
A (mm)	700 to 1200	700 to 1200	700 to 1200	700 to 1200
B (mm)	200	200	290	290
C (mm)	-	-	-	-
D (mm)	-	-	-	-
Fire Barrier	Yes	Yes	Yes	Yes
Fire Barrier Position	On side A	On side A	On side A	On side A

Additional Characteristics				
IP	IP55	IP55	IP55	IP55
Color	White	White	White	White
Weight (kg)	-	-	-	-
Selling Unit	1	1	1	1
MOQ	1	1	1	1

A dimension can be adjusted in increments of 5 mm. See A minimum and maximum. Fire barrier position on side A is adjustable in increments of 10 mm respecting the Xb and Yb minimum. B dimension is fixed.

To order, indicate for example: KSA400DLL42F, A = 900, Xa = 500, Ya = 400

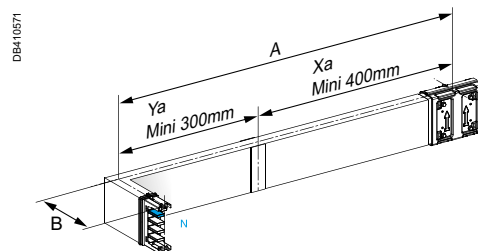

KSA100 to 400 DLL 42F

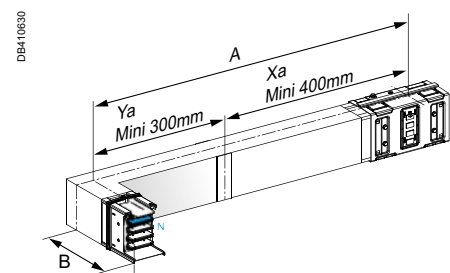

KSA500 to 1000 DLL 42F

Advanced offer

Change direction elements

Elbows

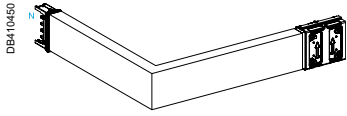

To turn Left at 90° (Edgewise position)
Sides A and B are made-to-measure

Cat. n°	KSA250DLR43A	KSA400DLR43A	KSA630DLR43A	KSA1000DLR43A
Compatible with	KSA100 to 250	KSA400	KSA500 to 1000	KSA500 to 1000
A in the line (mm)	400 to 1500	400 to 1500	580 to 1600	580 to 1600
Rating (A)	250	400	630	1000
Polarity	3L + N + PE	3L + N + PE	3L + N + PE	3L + N + PE

KSA100 to 400 DLR 43A

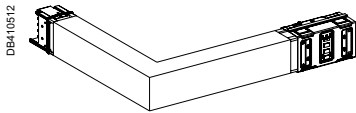

KSA500 to 1000 DLR 43A

Dimensions				
A (mm)	200 to 750	200 to 750	290 to 800	290 to 800
B (mm)	200 to 750	200 to 750	290 to 800	290 to 800
C (mm)	-	-	-	-
D (mm)	-	-	-	-
Fire Barrier	No	No	No	No
Fire Barrier Position	-	-	-	-

Additional Characteristics				
IP	IP55	IP55	IP55	IP55
Color	White	White	White	White
Weight (kg)	-	-	-	-
Selling Unit	1	1	1	1
MOQ	1	1	1	1

A and B dimensions can be adjusted in increments of 5 mm. See A and B minimum and maximum.

To order, indicate for example: KSA400DLR43A, A = 500, B = 500

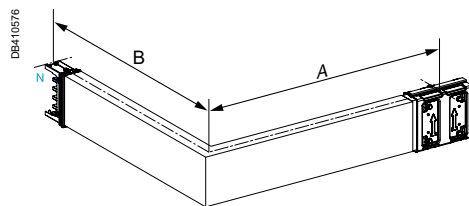

KSA250DLR43A

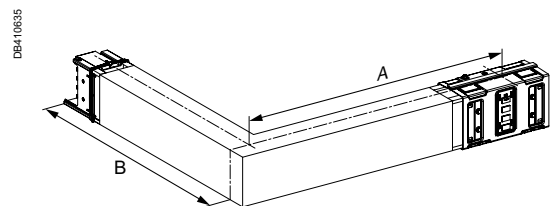

KSA500 to 1000 DLR 43A

Advanced offer

Change direction elements

Elbows

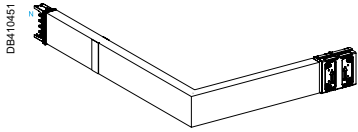

KSA100 to 400 DLR 43F

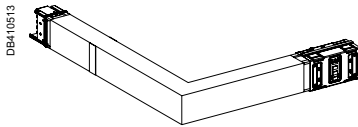

KSA500 to 1000 DLR 43F

To turn Left at 90° (Edgewise position)
Sides A and B are made-to-measure including 1 Fire Barrier (FB) on 1 side

Cat. n°	KSA250DLR43F	KSA400DLR43F	KSA630DLR43F	KSA1000DLR43F
Compatible with	KSA100 to 250	KSA400	KSA500 to 1000	KSA500 to 1000
A in the line (mm)	900 to 1950	900 to 1950	990 to 2000	990 to 2000
Rating (A)	250	400	630	1000
Polarity	3L + N + PE	3L + N + PE	3L + N + PE	3L + N + PE

Dimensions				
A (mm)	(200 to 750) or (700 to 1200) if FB	(200 to 750) or (700 to 1200) if FB	(290 to 800) or (700 to 1200) if FB	(290 to 800) or (700 to 1200) if FB
B (mm)	(200 to 750) or (700 to 1200) if FB	(200 to 750) or (700 to 1200) if FB	(290 to 800) or (700 to 1200) if FB	(290 to 800) or (700 to 1200) if FB
C (mm)	-	-	-	-
D (mm)	-	-	-	-
Fire Barrier	Yes	Yes	Yes	Yes
Fire Barrier Position	Either on side A or B	Either on side A or B	Either on side A or B	Either on side A or B

Additional Characteristics				
IP	IP55	IP55	IP55	IP55
Color	White	White	White	White
Weight (kg)	-	-	-	-
Selling Unit	1	1	1	1
MOQ	1	1	1	1

A and B dimensions can be adjusted in increments of 5 mm. See A and B minimum and maximum. One Fire barrier can be positioned on side A or on side B. Fire barrier position is adjustable in increments of 10 mm respecting the Xa and Ya or Xb and Yb minimum
To order, indicate for example: KSA400DLR43F, A = 500, B = 900, Xb = 450, Yb = 450

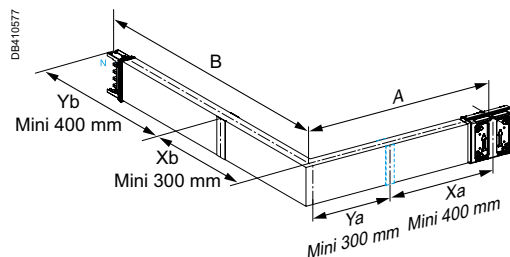

KSA100 to 400 DLR 43F

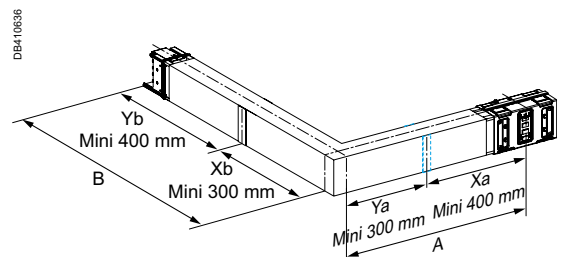

KSA500 to 1000 DLR 43F



Advanced offer

Change direction elements

Elbows

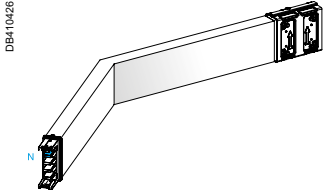

KSA100 to 400 DLC 43B

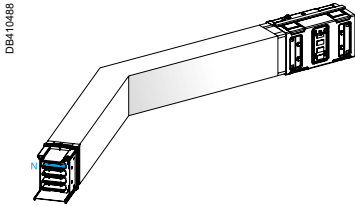

KSA500 to 1000 DLC 43B

To turn Right or Left with Special Angle (Edgewise position)
Sides A and B are made-to-measure

Cat. n°	KSA250DLC43B	KSA400DLC43B	KSA630DLC43B	KSA1000DLC43B
Compatible with	KSA100 to 250	KSA400	KSA500 to 1000	KSA500 to 1000
A in the line (mm)	400 to 1500	400 to 1500	580 to 1600	580 to 1600
Rating (A)	250	400	630	1000
Polarity	3L + N + PE	3L + N + PE	3L + N + PE	3L + N + PE

Dimensions				
A (mm)	200 to 750	200 to 750	290 to 800	290 to 800
B (mm)	200 to 750	200 to 750	290 to 800	290 to 800
C (mm)	-	-	-	-
D (mm)	-	-	-	-
Fire Barrier	No	No	No	No
Fire Barrier Position	-	-	-	-

Additional Characteristics				
IP	IP55	IP55	IP55	IP55
Color	White	White	White	White
Weight (kg)	-	-	-	-
Selling Unit	1	1	1	1
MOQ	1	1	1	1

A and B dimensions can be adjusted in increments of 5 mm. See A and B minimum and maximum. Angle of the elbow can also be adjusted from 90° to 180° in increments of 10°

To order, indicate for example: KSA400DLC43B, A = 500, B = 500, W = 120°

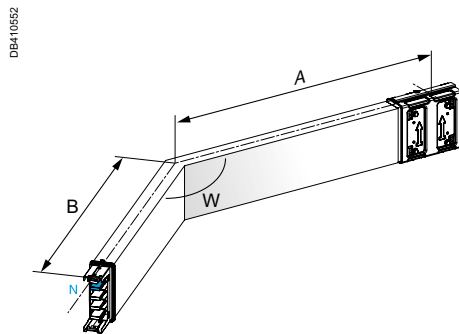

KSA100 to 400 DLC 43B

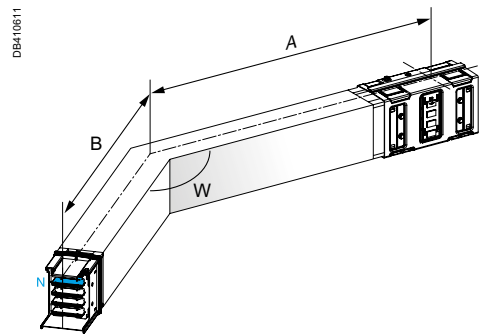

KSA500 to 1000 DLC 43B

Advanced offer

Change direction elements

Elbows

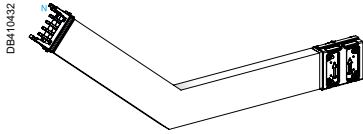

KSA100 to 400 DLE 43B

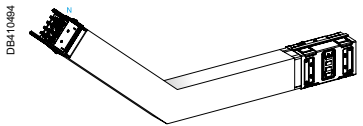

KSA500 to 1000 DLE 43B

To go Upward with Special Angle (Edgewise position)
Sides A and B are made-to-measure

Cat. n°	KSA250DLE43B	KSA400DLE43B	KSA630DLE43B	KSA1000DLE43B
Compatible with	KSA100 to 250	KSA400	KSA500 to 1000	KSA500 to 1000
A in the line (mm)	500 to 1500	500 to 1500	580 to 1600	580 to 1600
Rating (A)	250	400	630	1000
Polarity	3L + N + PE	3L + N + PE	3L + N + PE	3L + N + PE

Dimensions				
A (mm)	250 to 750	250 to 750	290 to 800	290 to 800
B (mm)	250 to 750	250 to 750	290 to 800	290 to 800
C (mm)	-	-	-	-
D (mm)	-	-	-	-
Fire Barrier	No	No	No	No
Fire Barrier Position	-	-	-	-

Additional Characteristics				
IP	IP55	IP55	IP55	IP55
Color	White	White	White	White
Weight (kg)	-	-	-	-
Selling Unit	1	1	1	1
MOQ	1	1	1	1

A and B dimensions can be adjusted in increments of 5 mm. See A and B minimum and maximum.
Angle of the elbow can also be adjusted from 90° to 180° in increments of 10°

To order, indicate for example: KSA400DLE43B, A = 500, B = 500, W = 120°

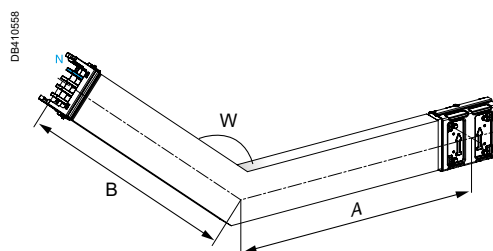

KSA100 to 400 DLE 43B

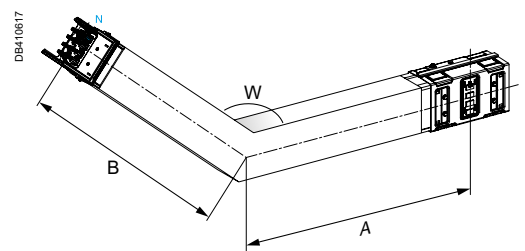

KSA500 to 1000 DLE 43B

Advanced offer

Change direction elements

Elbows

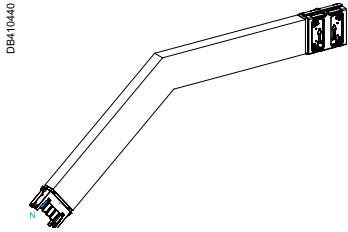

KSA100 to 400 DLF 43B

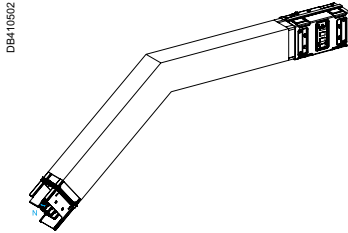

KSA500 to 1000 DLF 43B

To go Downward with Special Angle (Edgewise position)
Sides A and B are made-to-measure

Cat. n°	KSA250DLF43B	KSA400DLF43B	KSA630DLF43B	KSA1000DLF43B
Compatible with	KSA100 to 250	KSA400	KSA500 to 1000	KSA500 to 1000
A in the line (mm)	500 to 1500	500 to 1500	580 to 1600	580 to 1600
Rating (A)	250	400	630	1000
Polarity	3L + N + PE	3L + N + PE	3L + N + PE	3L + N + PE

Dimensions				
A (mm)	250 to 750	250 to 750	290 to 800	290 to 800
B (mm)	250 to 750	250 to 750	290 to 800	290 to 800
C (mm)	-	-	-	-
D (mm)	-	-	-	-
Fire Barrier	No	No	No	No
Fire Barrier Position	-	-	-	-

Additional Characteristics				
IP	IP55	IP55	IP55	IP55
Color	White	White	White	White
Weight (kg)	-	-	-	-
Selling Unit	1	1	1	1
MOQ	1	1	1	1

A and B dimensions can be adjusted in increments of 5 mm. See A and B minimum and maximum. Angle of the elbow can also be adjusted from 90° to 180° in increments of 10°

To order, indicate for example: KSA400DLF43B, A = 500, B = 500, W = 120°

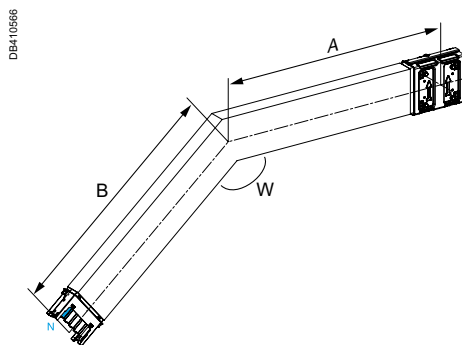

KSA100 to 400 DLF 43B

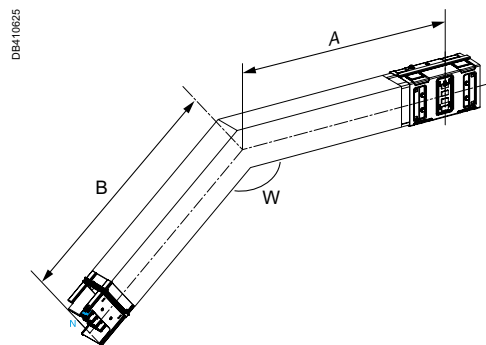

KSA500 to 1000 DLF 43B

Advanced offer

Change direction elements

Zeds

DB410468

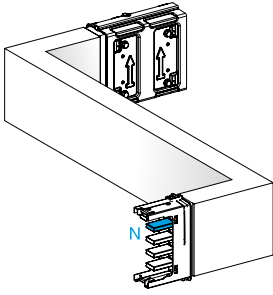

2 Turns at 90° - first Left, then Right (Edgewise position)
Sides A and C are fixed, Side B is made-to-measure

Cat. n°	KSA250DZCG41A	KSA400DZCG41A	KSA630DZCG41A	KSA1000DZCG41A
Compatible with	KSA100 to 250	KSA400	KSA500 to 1000	KSA500 to 1000
A in the line (mm)	600 to 1250	600 to 1250	780 to 1400	780 to 1400
Rating (A)	250	400	630	1000
Polarity	3L + N + PE	3L + N + PE	3L + N + PE	3L + N + PE

KSA100 to 400 DZCG 41A

DB410531

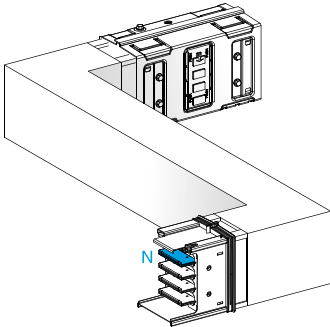

Dimensions				
A (mm)	200	200	290	290
B (mm)	200 to 750	200 to 750	200 to 800	200 to 800
C (mm)	200	200	290	290
D (mm)	-	-	-	-
Fire Barrier	No	No	No	No
Fire Barrier Position	-	-	-	-

KSA500 to 1000 DZCG 41A

Additional Characteristics				
IP	IP55	IP55	IP55	IP55
Color	White	White	White	White
Weight (kg)	-	-	-	-
Selling Unit	1	1	1	1
MOQ	1	1	1	1

A and C dimensions are fixed. B dimension can be adjusted in increments of 5 mm.
 See B minimum and maximum.

To order, indicate for example: KSA400DZCG41A, B = 500

DB410584

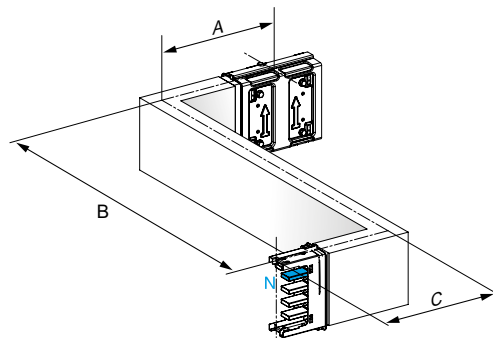

KSA100 to 400 DZCG 41A

DB410654

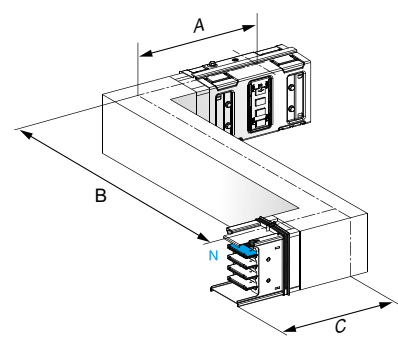

KSA500 to 1000 DZCG 41A

Advanced offer

Change direction elements

Zeds

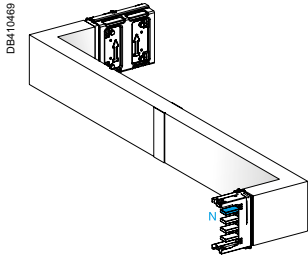

2 Turns at 90° - first Left, then Right (Edgewise position)
Sides A and C are fixed, Side B is made-to-measure including a fire Barrier

Cat. n°	KSA250DZCG41F	KSA400DZCG41F	KSA630DZCG41F	KSA1000DZCG41F
Compatible with	KSA100 to 250	KSA400	KSA500 to 1000	KSA500 to 1000
A in the line (mm)	1200 to 1700	1200 to 1700	1280 to 1800	1280 to 1800
Rating (A)	250	400	630	1000
Polarity	3L + N + PE	3L + N + PE	3L + N + PE	3L + N + PE

KSA100 to 400 DZCG 41F

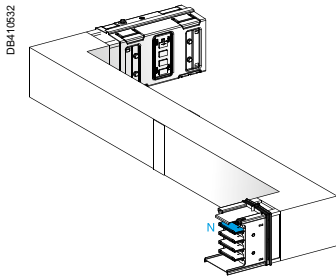

KSA500 to 1000 DZCG 41F

Dimensions				
A (mm)	200	200	290	290
B (mm)	700 to 1200	700 to 1200	700 to 1200	700 to 1200
C (mm)	200	200	290	290
D (mm)	-	-	-	-
Fire Barrier	Yes	Yes	Yes	Yes
Fire Barrier Position	On side B	On side B	On side B	On side B



Additional Characteristics				
IP	IP55	IP55	IP55	IP55
Color	White	White	White	White
Weight (kg)	-	-	-	-
Selling Unit	1	1	1	1
MOQ	1	1	1	1

A and C dimensions are fixed. B dimension can be adjusted in increments of 5 mm.
 See B minimum and maximum. Fire barrier position on side B is adjustable in increments of 10 mm respecting the Xb and Yb minimum.
 To order, indicate for example: KSA400DZCG41F, B = 900, Xb = 500, Yb = 400

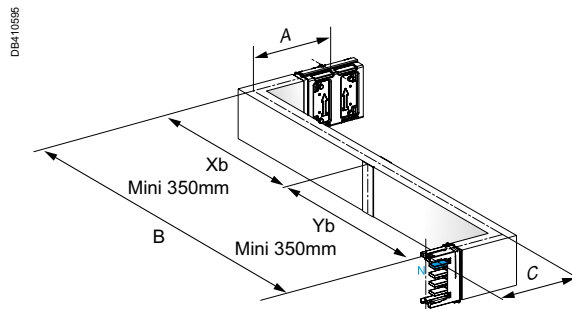

KSA100 to 400 DZCG 41F

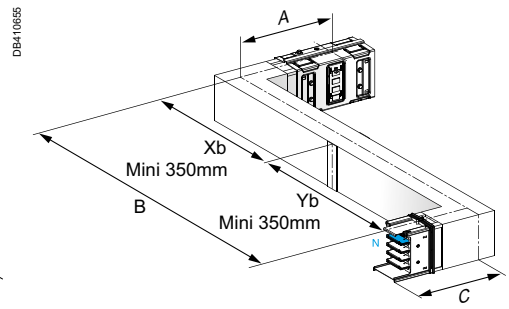

KSA500 to 1000 DZCG 41F

Advanced offer

Change direction elements

Zeds

DB410470

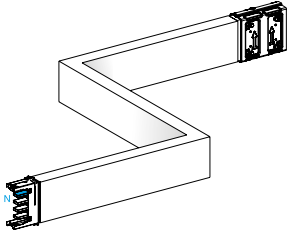

2 Turns at 90° - first Left, then Right (Edgewise position)
Sides A, B, C are made-to-measure

Cat. n°	KSA250DZCG43A	KSA400DZCG43A	KSA630DZCG43A	KSA1000DZCG43A
Compatible with	KSA100 to 250	KSA400	KSA500 to 1000	KSA500 to 1000
A in the line (mm)	600 to 2250	600 to 2250	870 to 2400	870 to 2400
Rating (A)	250	400	630	1000
Polarity	3L + N + PE	3L + N + PE	3L + N + PE	3L + N + PE

KSA100 to 400 DZCG 43A

DB410533

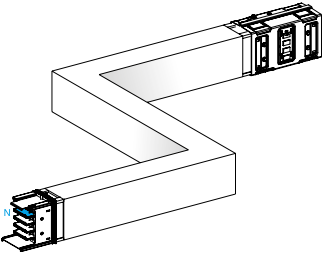

KSA500 to 1000 DZCG 43A

Dimensions				
A (mm)	200 to 750	200 to 750	290 to 800	290 to 800
B (mm)	200 to 750	200 to 750	290 to 800	290 to 800
C (mm)	200 to 750	200 to 750	290 to 800	290 to 800
D (mm)	-	-	-	-
Fire Barrier	No	No	No	No
Fire Barrier Position	-	-	-	-

Additional Characteristics				
IP	IP55	IP55	IP55	IP55
Color	White	White	White	White
Weight (kg)	-	-	-	-
Selling Unit	1	1	1	1
MOQ	1	1	1	1

A, B and C dimensions can be adjusted in increments of 5 mm. See A,B and C minimum and maximum.

To order, indicate for example: KSA400DZCG43A, A = 400, B = 500, C = 600

DB410386

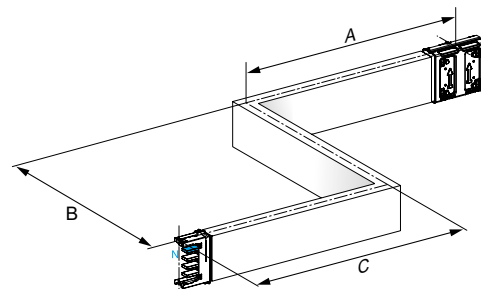

KSA100 to 400 DZCG 43A

DB410389

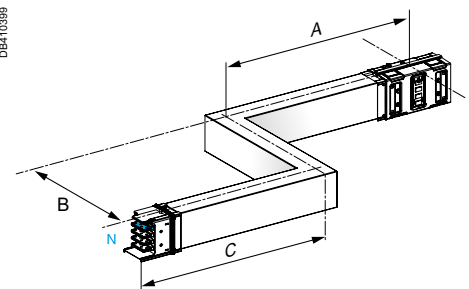

KSA500 to 1000 DZCG 43A

Advanced offer

Change direction elements

Zeds

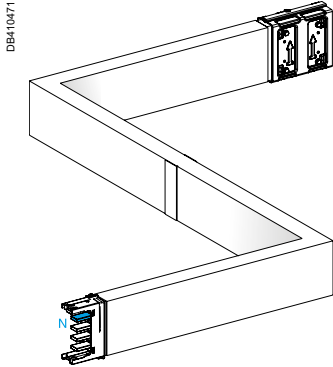

KSA100 to 400 DZCG 43F

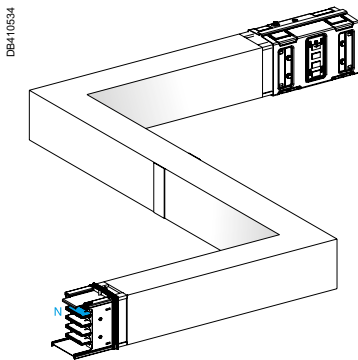

KSA500 to 1000 DZCG 43F

2 Turns at 90° - first Left, then Right (Edgewise position)
Sides A, B, C are made-to-measure including 1 fire Barrier on 1 branche

Cat. n°	KSA250DZCG43F	KSA400DZCG43F	KSA630DZCG43F	KSA1000DZCG43F
Compatible with	KSA100 to 250	KSA400	KSA500 to 1000	KSA500 to 1000
A in the line (mm)	1100 to 2700	1100 to 2700	1280 to 2800	1280 to 2800
Rating (A)	250	400	630	1000
Polarity	3L + N + PE	3L + N + PE	3L + N + PE	3L + N + PE

Dimensions				
A (mm)	(200 to 750) or (700 to 1200) if FB	(200 to 750) or (700 to 1200) if FB	(290 to 800) or (700 to 1200) if FB	(290 to 800) or (700 to 1200) if FB
B (mm)	(200 to 750) or (700 to 1200) if FB	(200 to 750) or (700 to 1200) if FB	(200 to 800) or (700 to 1200) if FB	(200 to 800) or (700 to 1200) if FB
C (mm)	(200 to 750) or (700 to 1200) if FB	(200 to 750) or (700 to 1200) if FB	(290 to 800) or (700 to 1200) if FB	(290 to 800) or (700 to 1200) if FB
D (mm)	-	-	-	-
Fire Barrier	Yes	Yes	Yes	Yes
Fire Barrier Position	Either on side A or B or C	Either on side A or B or C	Either on side A or B or C	Either on side A or B or C

Additional Characteristics				
IP	IP55	IP55	IP55	IP55
Color	White	White	White	White
Weight (kg)	-	-	-	-
Selling Unit	1	1	1	1
MOQ	1	1	1	1

A, B and C dimensions can be adjusted in increments of 5 mm. See A, B and C minimum and maximum. One Fire barrier can be positioned either on side A, B or C. Fire barrier position is adjustable in increments of 10 mm respecting the minimum.

To order, indicate for example: KSA400DZCG43F, A = 400, B = 900, Xb = 450, Yb = 450, C = 600

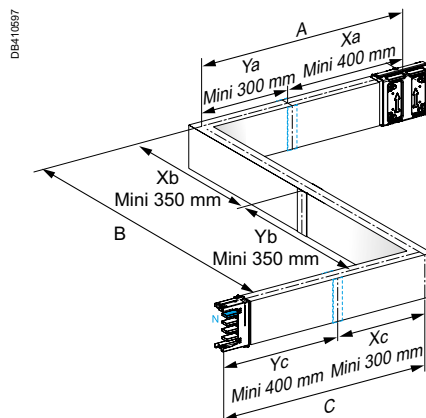

KSA100 to 400 DZCG 43F

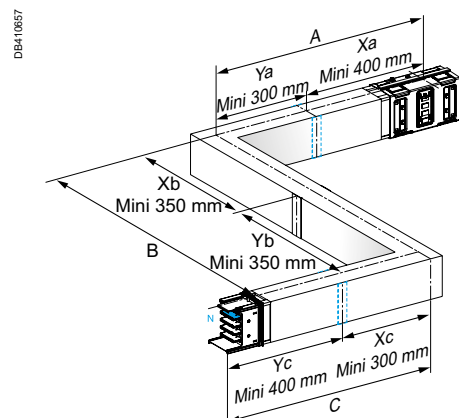

KSA500 to 1000 DZCG 43F

Advanced offer

Change direction elements

Zeds

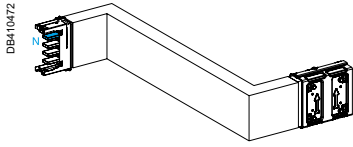

KSA100 to 400 DZCH 41A

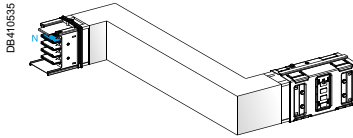

KSA500 to 1000 DZCH 41A

2 Turns at 90° - first Right, then Left (Edgewise position)
Sides A and C are fixed, Side B is made-to-measure

Cat. n°	KSA250DZCH41A	KSA400DZCH41A	KSA630DZCH41A	KSA1000DZCH41A
Compatible with	KSA100 to 250	KSA400	KSA500 to 1000	KSA500 to 1000
A in the line (mm)	600 to 1250	600 to 1250	780 to 1400	780 to 1400
Rating (A)	250	400	630	1000
Polarity	3L + N + PE	3L + N + PE	3L + N + PE	3L + N + PE

Dimensions				
A (mm)	200	200	290	290
B (mm)	200 to 750	200 to 750	200 to 800	200 to 800
C (mm)	200	200	290	290
D (mm)	-	-	-	-
Fire Barrier	No	No	No	No
Fire Barrier Position	-	-	-	-

Additional Characteristics				
IP	IP55	IP55	IP55	IP55
Color	White	White	White	White
Weight (kg)	-	-	-	-
Selling Unit	1	1	1	1
MOQ	1	1	1	1

A and C dimensions are fixed. B dimension can be adjusted in increments of 5 mm.
 See B minimum and maximum.

To order, indicate for example: KSA400DZCH41A, B = 500

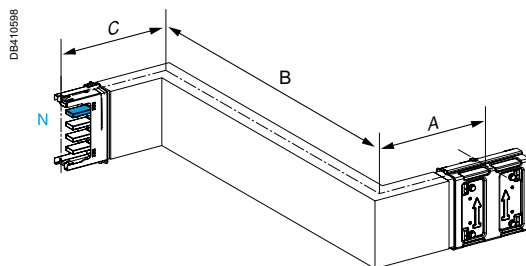

KSA100 to 400 DZCH 41A

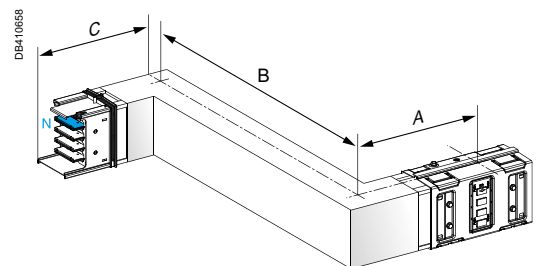

KSA500 to 1000 DZCH 41A

Advanced offer

Change direction elements

Zeds

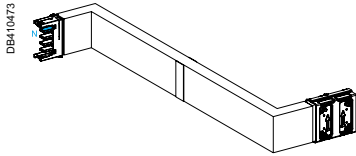

KSA100 to 400 DZCH 41F

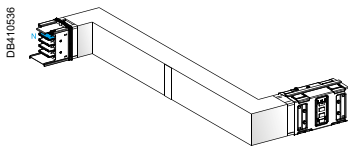

KSA500 to 1000 DZCH 41F

2 Turns at 90° - first Right, then Left (Edgewise position)
Sides A and C are fixed, Side B is made-to-measure including a fire Barrier

Cat. n°	KSA250DZCH41F	KSA400DZCH41F	KSA630DZCH41F	KSA1000DZCH41F
Compatible with	KSA100 to 250	KSA400	KSA500 to 1000	KSA500 to 1000
A in the line (mm)	1100 to 1700	1100 to 1700	1280 to 1800	1280 to 1800
Rating (A)	250	400	630	1000
Polarity	3L + N + PE	3L + N + PE	3L + N + PE	3L + N + PE

Dimensions				
A (mm)	200	200	290	290
B (mm)	700 to 1200	700 to 1200	700 to 1200	700 to 1200
C (mm)	200	200	290	290
D (mm)	-	-	-	-
Fire Barrier	Yes	Yes	Yes	Yes
Fire Barrier Position	On side B	On side B	On side B	On side B

Additional Characteristics				
IP	IP55	IP55	IP55	IP55
Color	White	White	White	White
Weight (kg)	-	-	-	-
Selling Unit	1	1	1	1
MOQ	1	1	1	1

A and C dimensions are fixed. B dimension can be adjusted in increments of 5 mm.
 See B minimum and maximum. Fire barrier position on side B is adjustable in increments of 10 mm respecting the Xb and Yb minimum.
 To order, indicate for example: KSA400DZCH41F, B = 900, Xb = 500, Yb = 400

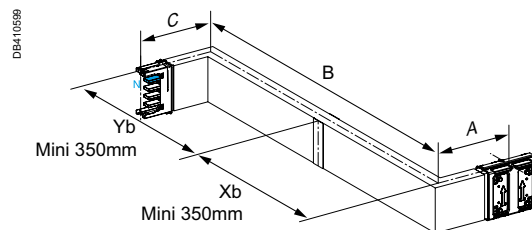

KSA100 to 400 DZCH 41F

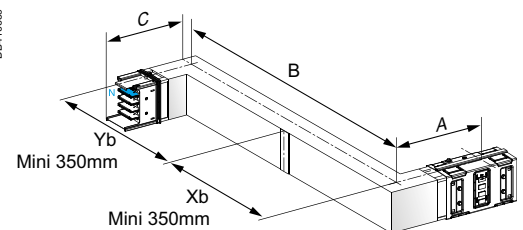

KSA500 to 1000 DZCH 41F

Advanced offer

Change direction elements

Zeds

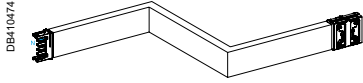

KSA100 to 400 DZCH 43A

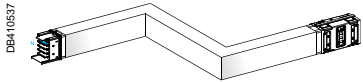

KSA500 to 1000 DZCH 43A

2 Turns at 90° - first Right, then Left (Edgewise position)
Sides A, B, C are made-to-measure

Cat. n°	KSA250DZCH43A	KSA400DZCH43A	KSA630DZCH43A	KSA1000DZCH43A
Compatible with	KSA100 to 250	KSA400	KSA500 to 1000	KSA500 to 1000
A in the line (mm)	600 to 2250	600 to 2250	780 to 2400	780 to 2400
Rating (A)	250	400	630	1000
Polarity	3L + N + PE	3L + N + PE	3L + N + PE	3L + N + PE

Dimensions				
A (mm)	200 to 750	200 to 750	290 to 800	290 to 800
B (mm)	200 to 750	200 to 750	200 to 800	200 to 800
C (mm)	200 to 750	200 to 750	290 to 800	290 to 800
D (mm)	-	-	-	-
Fire Barrier	No	No	No	No
Fire Barrier Position	-	-	-	-

Additional Characteristics				
IP	IP55	IP55	IP55	IP55
Color	White	White	White	White
Weight (kg)	-	-	-	-
Selling Unit	1	1	1	1
MOQ	1	1	1	1

A, B and C dimensions can be adjusted in increments of 5 mm. See A,B and C minimum and maximum.

To order, indicate for example: KSA400DZCH43A, A = 400, B = 500, C = 600

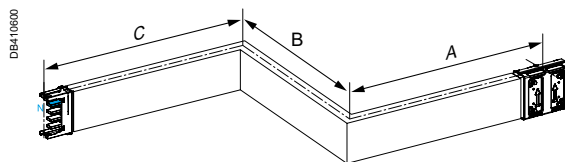

KSA100 to 400 DZCH 43A

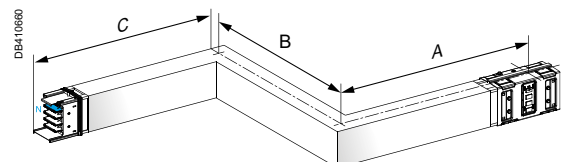

KSA500 to 1000 DZCH 43A

Advanced offer

Change direction elements

Zeds

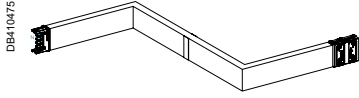

KSA100 to 400 DZCH 43F

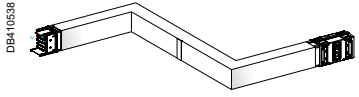

KSA500 to 1000 DZCH 43F

2 Turns at 90° - first Right, then Left (Edgewise position)
Sides A, B, C are made-to-measure including 1 fire Barrier on 1 branche

Cat. n°	KSA250DZCH43F	KSA400DZCH43F	KSA630DZCH43F	KSA1000DZCH43F
Compatible with	KSA100 to 250	KSA400	KSA500 to 1000	KSA500 to 1000
A in the line (mm)	1100 to 2700	1100 to 2700	1280 to 2800	1280 to 2800
Rating (A)	250	400	630	1000
Polarity	3L + N + PE	3L + N + PE	3L + N + PE	3L + N + PE

Dimensions

A (mm)	(200 to 750) or (700 to 1200) if FB	(200 to 750) or (700 to 1200) if FB	(290 to 800) or (700 to 1200) if FB	(290 to 800) or (700 to 1200) if FB
B (mm)	(200 to 750) or (700 to 1200) if FB	(200 to 750) or (700 to 1200) if FB	(200 to 800) or (700 to 1200) if FB	(200 to 800) or (700 to 1200) if FB
C (mm)	(200 to 750) or (700 to 1200) if FB	(200 to 750) or (700 to 1200) if FB	(290 to 800) or (700 to 1200) if FB	(290 to 800) or (700 to 1200) if FB
D (mm)	-	-	-	-
Fire Barrier	Yes	Yes	Yes	Yes
Fire Barrier Position	Either on side A or B or C	Either on side A or B or C	Either on side A or B or C	Either on side A or B or C

Additional Characteristics

IP	IP55	IP55	IP55	IP55
Color	White	White	White	White
Weight (kg)	-	-	-	-
Selling Unit	1	1	1	1
MOQ	1	1	1	1

A, B and C dimensions can be adjusted in increments of 5 mm. See A, B and C minimum and maximum.
 One Fire barrier can be positioned either on side A, B or C. Fire barrier position is adjustable in increments of 10 mm respecting the minimum.

To order, indicate for example: KSA400DZCH43F, A = 400, B = 900, Xb = 450, Yb = 450, C = 600

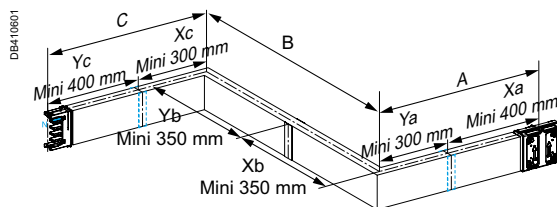

KSA100 to 400 DZCH 43F

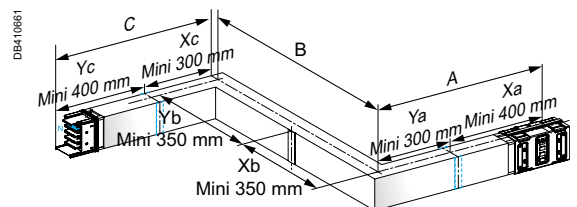

KSA500 to 1000 DZCH 43F

Advanced offer

Change direction elements

Zeds

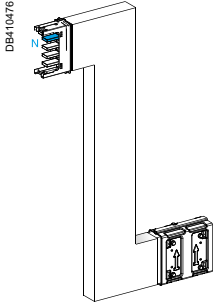

2 Turns at 90° - Upward or Downward (reversible), then straight (Edgewise position)
Sides A and C are fixed, Side B is made-to-measure

Cat. n°	KSA250DZE41A	KSA400DZE41A	KSA630DZE41A	KSA1000DZE41A
Compatible with	KSA100 to 250	KSA400	KSA500 to 1000	KSA500 to 1000
A in the line (mm)	700 to 1250	700 to 1250	780 to 1400	780 to 1400
Rating (A)	250	400	630	1000
Polarity	3L + N + PE	3L + N + PE	3L + N + PE	3L + N + PE

KSA100 to 400 DZE 41A

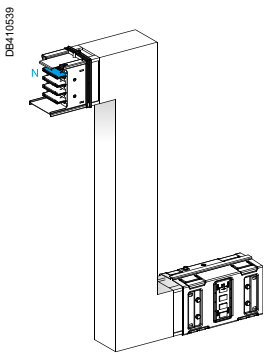

Dimensions				
A (mm)	250	250	280	280
B (mm)	200 to 750	200 to 750	200 to 800	200 to 800
C (mm)	250	250	290	290
D (mm)	-	-	-	-
Fire Barrier	No	No	No	No
Fire Barrier Position	-	-	-	-

KSA500 to 1000 DZE 41A

Additional Characteristics				
IP	IP55	IP55	IP55	IP55
Color	White	White	White	White
Weight (kg)	-	-	-	-
Selling Unit	1	1	1	1
MOQ	1	1	1	1

A and C dimensions are fixed. B dimension can be adjusted in increments of 5 mm. See B minimum and maximum.

To order, indicate for example: KSA400DZE41A, B = 500

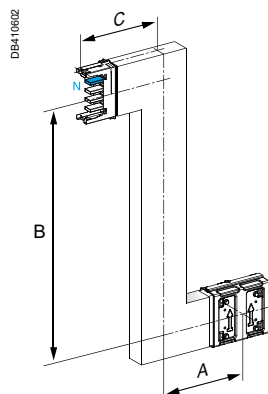

KSA100 to 400 DZE 41A

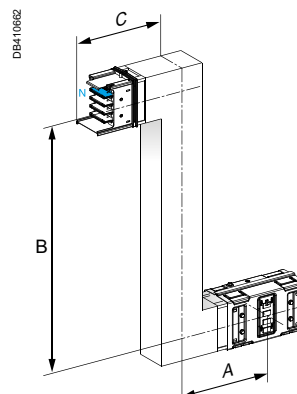

KSA500 to 1000 DZE 41A

Advanced offer

Change direction elements

Zeds

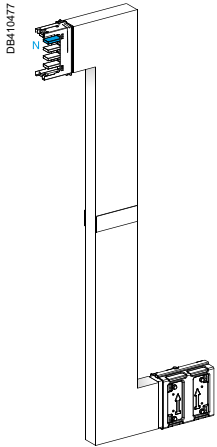

KSA100 to 400 DZE 41F

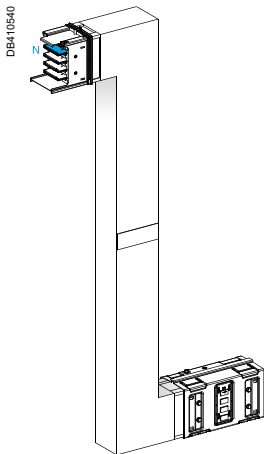

KSA500 to 1000 DZE 41F

2 Turns at 90° - Upward or Downward (reversible), then straight (Edgewise position)
Sides A and C are fixed, Side B is made-to-measure including a fire Barrier

Cat. n°	KSA250DZE41F	KSA400DZE41F	KSA630DZE41F	KSA1000DZE41F
Compatible with	KSA100 to 250	KSA400	KSA500 to 1000	KSA500 to 1000
A in the line (mm)	1200 to 1700	1200 to 1700	1280 to 1800	1280 to 1800
Rating (A)	250	400	630	1000
Polarity	3L + N + PE	3L + N + PE	3L + N + PE	3L + N + PE

Dimensions				
A (mm)	250	250	290	290
B (mm)	700 to 1200	700 to 1200	700 to 1200	700 to 1200
C (mm)	250	250	290	290
D (mm)	-	-	-	-
Fire Barrier	Yes	Yes	Yes	Yes
Fire Barrier Position	On side B	On side B	On side B	On side B

Additional Characteristics				
IP	IP55	IP55	IP55	IP55
Color	White	White	White	White
Weight (kg)	-	-	-	-
Selling Unit	1	1	1	1
MOQ	1	1	1	1

A and C dimensions are fixed. B dimension can be adjusted in increments of 5 mm.
 See B minimum and maximum. Fire barrier position on side B is adjustable in increments of 10 mm respecting the Xb and Yb minimum.

To order, indicate for example: KSA400DZE41F, B = 900, Xb = 500, Yb = 400

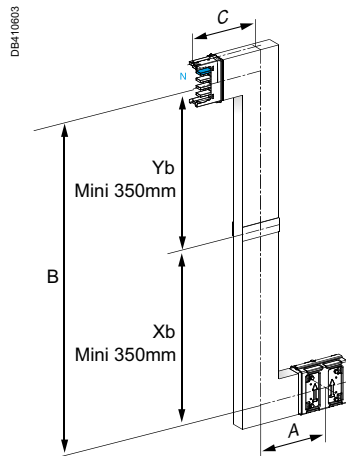

KSA100 to 400 DZE 41F

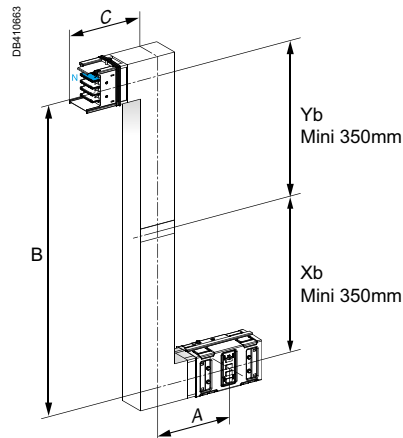

KSA500 to 1000 DZE 41F



Advanced offer

Change direction elements

Zeds

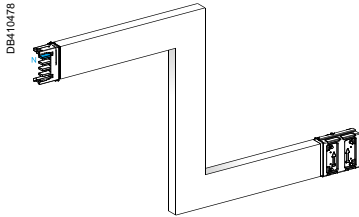

KSA100 to 400 DZE 43A

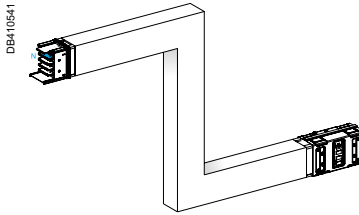

KSA500 to 1000 DZE 43A

2 Turns at 90° - Upward or Downward (reversible), then straight (Edgewise position)
Sides A, B, C are made-to-measure

Cat. n°	KSA250DZE43A	KSA400DZE43A	KSA630DZE43A	KSA1000DZE43A
Compatible with	KSA100 to 250	KSA400	KSA500 to 1000	KSA500 to 1000
A in the line (mm)	700 to 2250	700 to 2250	780 to 2400	780 to 2400
Rating (A)	250	400	630	1000
Polarity	3L + N + PE	3L + N + PE	3L + N + PE	3L + N + PE

Dimensions				
A (mm)	250 to 750	250 to 750	290 to 800	290 to 800
B (mm)	200 to 750	200 to 750	200 to 800	200 to 800
C (mm)	250 to 750	250 to 750	290 to 800	290 to 800
D (mm)	-	-	-	-
Fire Barrier	No	No	No	No
Fire Barrier Position	-	-	-	-

Additional Characteristics				
IP	IP55	IP55	IP55	IP55
Color	White	White	White	White
Weight (kg)	-	-	-	-
Selling Unit	1	1	1	1
MOQ	1	1	1	1

A, B and C dimensions can be adjusted in increments of 5 mm. See A,B and C minimum and maximum.

To order, indicate for example: KSA400DZE43A, A = 400, B = 500, C = 600

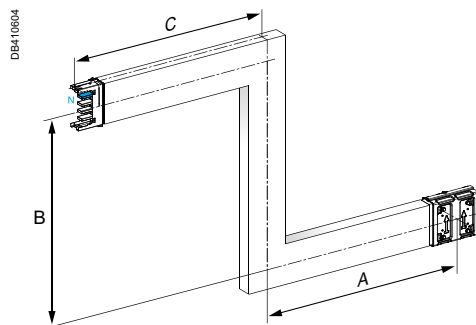

KSA100 to 400 DZE 43A

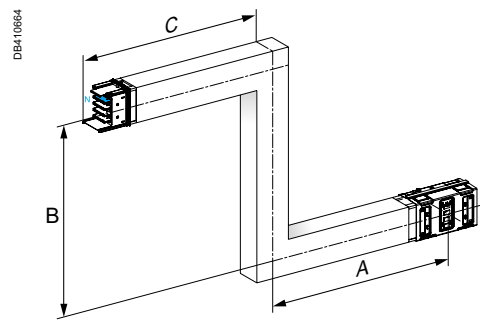

KSA500 to 1000 DZE 43A

Advanced offer

Change direction elements

Zeds

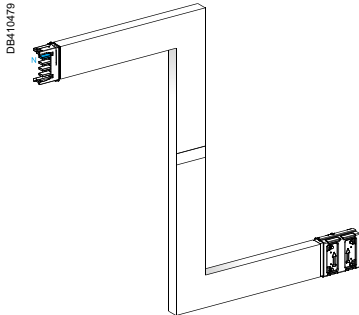

KSA100 to 400 DZE 43F

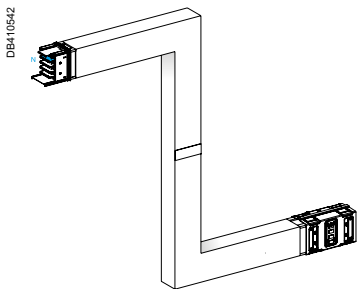

KSA500 to 1000 DZE 43F

2 Turns at 90° - Upward or Downward (reversible), then straight (Edgewise position)
Sides A, B, C are made-to-measure including 1 fire Barrier on 1 branche

Cat. n°	KSA250DZE43F	KSA400DZE43F	KSA630DZE43F	KSA1000DZE43F
Compatible with	KSA100 to 250	KSA400	KSA500 to 1000	KSA500 to 1000
A in the line (mm)	1150 to 2700	1200 to 2700	1280 to 2800	1280 to 2800
Rating (A)	250	400	630	1000
Polarity	3L + N + PE	3L + N + PE	3L + N + PE	3L + N + PE

Dimensions				
A (mm)	(250 to 750) or (700 to 1200) if FB	(250 to 750) or (700 to 1200) if FB	(290 to 800) or (700 to 1200) if FB	(290 to 800) or (700 to 1200) if FB
B (mm)	(200 to 750) or (700 to 1200) if FB	(200 to 750) or (700 to 1200) if FB	(200 to 800) or (700 to 1200) if FB	(200 to 800) or (700 to 1200) if FB
C (mm)	(250 to 750) or (700 to 1200) if FB	(250 to 750) or (700 to 1200) if FB	(290 to 800) or (700 to 1200) if FB	(290 to 800) or (700 to 1200) if FB
D (mm)	-	-	-	-
Fire Barrier	Yes	Yes	Yes	Yes
Fire Barrier Position	Either on side A or B or C	Either on side A or B or C	Either on side A or B or C	Either on side A or B or C

Additional Characteristics				
IP	IP55	IP55	IP55	IP55
Color	White	White	White	White
Weight (kg)	-	-	-	-
Selling Unit	1	1	1	1
MOQ	1	1	1	1

A, B and C dimensions can be adjusted in increments of 5 mm. See A, B and C minimum and maximum. One Fire barrier can be positioned either on side A, B or C. Fire barrier position is adjustable in increments of 10 mm respecting the minimum.

To order, indicate for example: KSA400DZE43F, A = 400, B = 900, Xb = 450, Yb = 450, C = 600

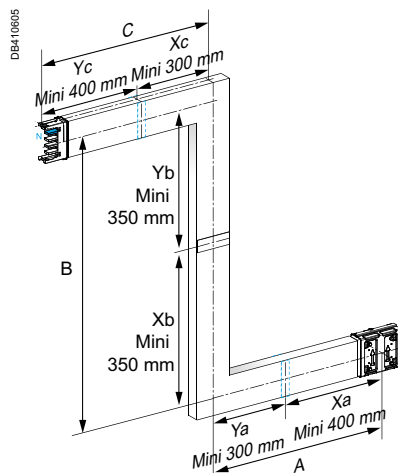

KSA100 to 400 DZE 43F

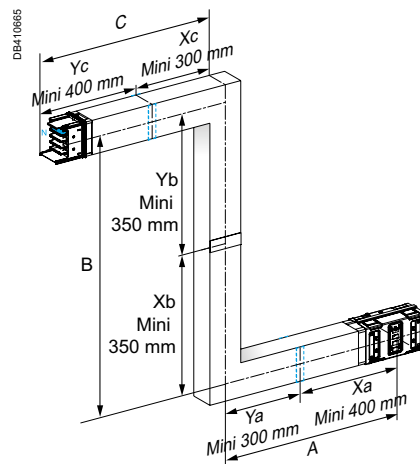

KSA500 to 1000 DZE 43F

Advanced offer

Change direction elements

Multiples

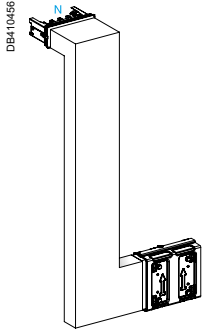

KSA100 to 400 DMBL 41A

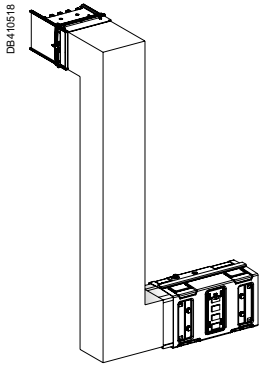

KSA500 to 1000 DMBL 41A

2 turns at 90° - Upward (Edgewise position), then turns right (Flat position)
Sides A and C are fixed, Side B is made-to-measure

Cat. n°	KSA250DMBL41A	KSA400DMBL41A	KSA630DMBL41A	KSA1000DMBL41A
Compatible with	KSA100 to 250	KSA400	KSA500 to 1000	KSA500 to 1000
A in the line (mm)	650 to 1250	650 to 1250	780 to 1400	780 to 1400
Rating (A)	250	400	630	1000
Polarity	3L + N + PE	3L + N + PE	3L + N + PE	3L + N + PE

Dimensions				
A (mm)	250	250	290	290
B (mm)	200 to 750	200 to 750	200 to 800	200 to 800
C (mm)	200	200	290	290
D (mm)	-	-	-	-
Fire Barrier	No	No	No	No
Fire Barrier Position	-	-	-	-

Additional Characteristics				
IP	IP55	IP55	IP55	IP55
Color	White	White	White	White
Weight (kg)	-	-	-	-
Selling Unit	1	1	1	1
MOQ	1	1	1	1

A and C dimensions are fixed. B dimension can be adjusted in increments of 5 mm.
 See B minimum and maximum.

To order, indicate for example: KSA400DMBL41A, B = 500

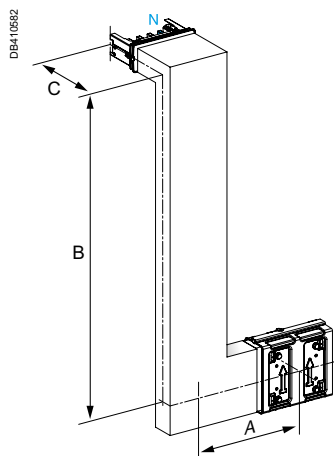

KSA100 to 400 DMBL 41A

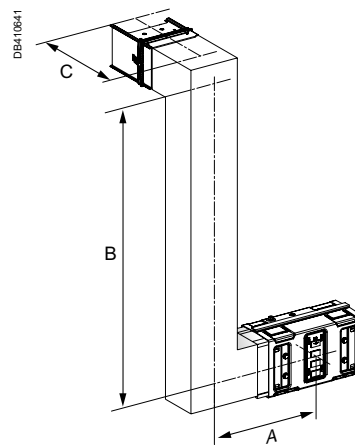

KSA500 to 1000 DMBL 41A

Advanced offer

Change direction elements

Multiples

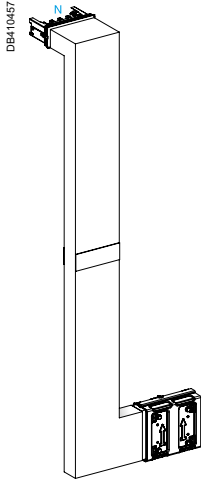

KSA100 to 400 DMBL 41F

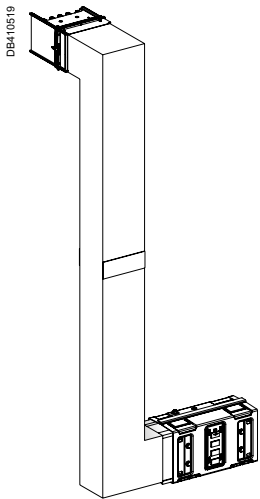

KSA500 to 1000 DMBL 41F

2 turns at 90° - Upward (Edgewise position), then turns right (Flat position)
Sides A and C are fixed, Side B is made-to-measure including a fire Barrier

Cat. n°	KSA250DMBL41F	KSA400DMBL41F	KSA630DMBL41F	KSA1000DMBL41F
Compatible with	KSA100 to 250	KSA400	KSA500 to 1000	KSA500 to 1000
A in the line (mm)	1150 to 1700	1150 to 1700	1280 to 1800	1280 to 1800
Rating (A)	250	400	630	1000
Polarity	3L + N + PE	3L + N + PE	3L + N + PE	3L + N + PE

Dimensions				
A (mm)	250	250	290	290
B (mm)	700 to 1200	700 to 1200	700 to 1200	700 to 1200
C (mm)	200	200	290	290
D (mm)	-	-	-	-
Fire Barrier	Yes	Yes	Yes	Yes
Fire Barrier Position	On side B	On side B	On side B	On side B

Additional Characteristics				
IP	IP55	IP55	IP55	IP55
Color	White	White	White	White
Weight (kg)	-	-	-	-
Selling Unit	1	1	1	1
MOQ	1	1	1	1

A and C dimensions are fixed. B dimension can be adjusted in increments of 5 mm.
 See B minimum and maximum. Fire barrier position on side B is adjustable in increments of 10 mm respecting the Xb and Yb minimum.
 To order, indicate for example: KSA400DMBL41F, B = 900, Xb = 500, Yb = 400

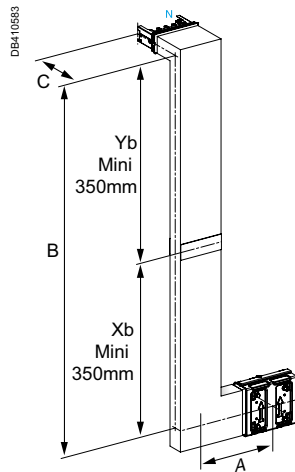

KSA100 to 400 DMBL 41F

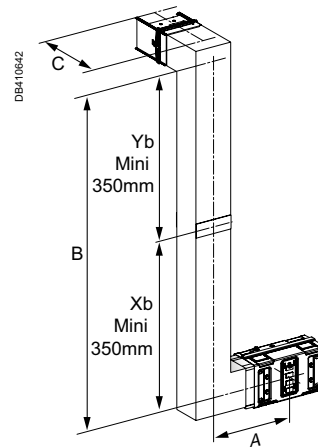

KSA500 to 1000 DMBL 41F

Advanced offer

Change direction elements

Multiples

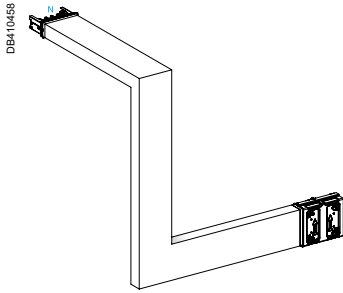

2 turns at 90° - Upward (Edgewise position), then turns right (Flat position)
Sides A, B, C are made-to-measure

Cat. n°	KSA250DMBL43A	KSA400DMBL43A	KSA630DMBL43A	KSA1000DMBL43A
Compatible with	KSA100 to 250	KSA400	KSA500 to 1000	KSA500 to 1000
A in the line (mm)	650 to 2250	650 to 2250	780 to 2400	780 to 2400
Rating (A)	250	400	630	1000
Polarity	3L + N + PE	3L + N + PE	3L + N + PE	3L + N + PE

KSA100 to 400 DMBL 43A

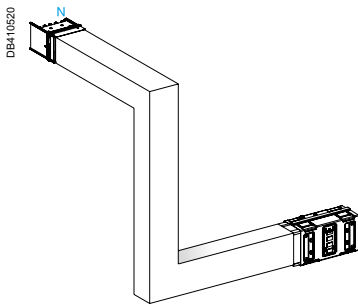

Dimensions				
A (mm)	250 to 750	250 to 750	290 to 800	290 to 800
B (mm)	200 to 750	200 to 750	200 to 800	200 to 800
C (mm)	200 to 750	200 to 750	290 to 800	290 to 800
D (mm)	-	-	-	-
Fire Barrier	No	No	No	No
Fire Barrier Position	-	-	-	-

KSA500 to 1000 DMBL 43A

Additional Characteristics				
IP	IP55	IP55	IP55	IP55
Color	White	White	White	White
Weight (kg)	-	-	-	-
Selling Unit	1	1	1	1
MOQ	1	1	1	1

A, B and C dimensions can be adjusted in increments of 5 mm. See A,B and C minimum and maximum.

To order, indicate for example: KSA400DMBL43A, A = 400, B = 500, C = 600

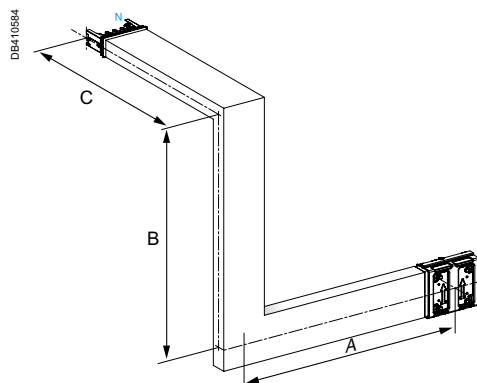

KSA100 to 400 DMBL 43A

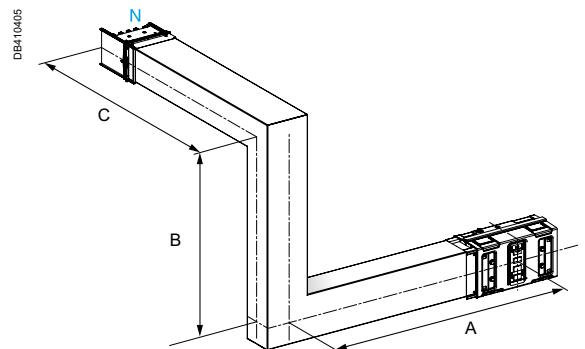

KSA500 to 1000 DMBL 43A

Advanced offer

Change direction elements

Multiples

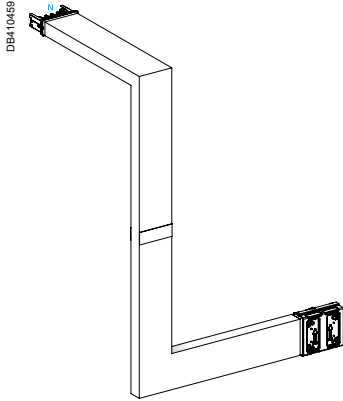

KSA100 to 400 DMBL 43F

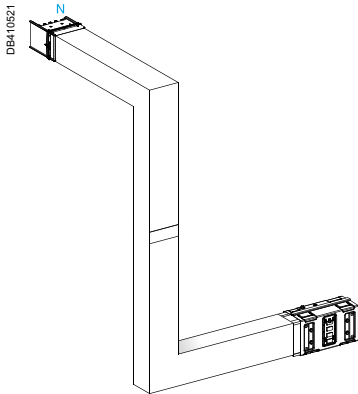

KSA500 to 1000 DMBL 43F

2 turns at 90° - Upward (Edgewise position), then turns right (Flat position)
Sides A, B, C are made-to-measure including 1 fire Barrier on 1 branche

Cat. n°	KSA250DMBL43F	KSA400DMBL43F	KSA630DMBL43F	KSA1000DMBL43F
Compatible with	KSA100 to 250	KSA400	KSA500 to 1000	KSA500 to 1000
A in the line (mm)	1150 to 2700	1150 to 2700	1280 to 2800	1280 to 2800
Rating (A)	250	400	630	1000
Polarity	3L + N + PE	3L + N + PE	3L + N + PE	3L + N + PE

Dimensions

A (mm)	(250 to 750) or (700 to 1200) if FB	(250 to 750) or (700 to 1200) if FB	(290 to 800) or (700 to 1200) if FB	(290 to 800) or (700 to 1200) if FB
B (mm)	(200 to 750) or (700 to 1200) if FB	(200 to 750) or (700 to 1200) if FB	(200 to 800) or (700 to 1200) if FB	(200 to 800) or (700 to 1200) if FB
C (mm)	(200 to 750) or (700 to 1200) if FB	(200 to 750) or (700 to 1200) if FB	(290 to 800) or (700 to 1200) if FB	(290 to 800) or (700 to 1200) if FB
D (mm)	-	-	-	-
Fire Barrier	Yes	Yes	Yes	Yes
Fire Barrier Position	Either on side A or B or C	Either on side A or B or C	Either on side A or B or C	Either on side A or B or C

Additional Characteristics

IP	IP55	IP55	IP55	IP55
Color	White	White	White	White
Weight (kg)	-	-	-	-
Selling Unit	1	1	1	1
MOQ	1	1	1	1

A, B and C dimensions can be adjusted in increments of 5 mm. See A, B and C minimum and maximum. One Fire barrier can be positioned either on side A, B or C. Fire barrier position is adjustable in increments of 10 mm respecting the minimum.

To order, indicate for example: KSA400DMBL43F, A = 400, B = 900, Xb = 450, Yb = 450, C = 600

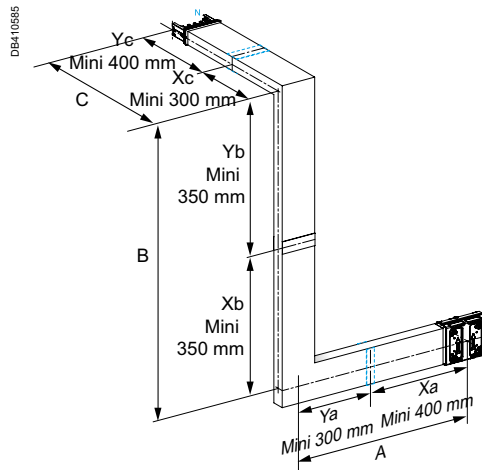

KSA100 to 400 DMBL 43F

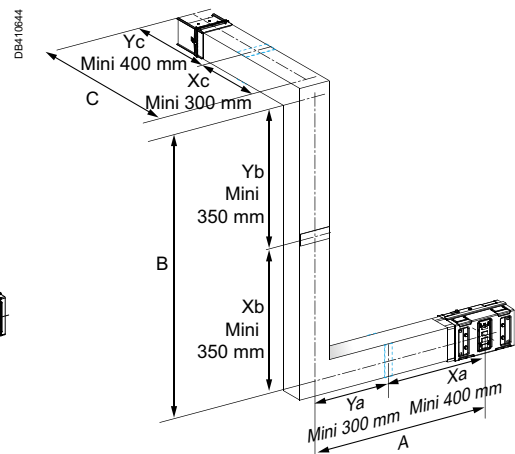

KSA500 to 1000 DMBL 43F

Advanced offer

Change direction elements

Multiples

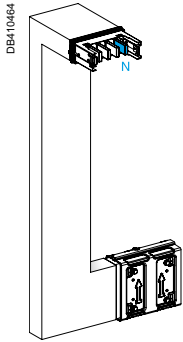

2 turns at 90° - Upward (Edgewise position), then turns left (Flat position)
Sides A and C are fixed, Side B is made-to-measure

Cat. n°	KSA250DMCL41A	KSA400DMCL41A	KSA630DMCL41A	KSA1000DMCL41A
Compatible with	KSA100 to 250	KSA400	KSA500 to 1000	KSA500 to 1000
A in the line (mm)	650 to 1250	650 to 1400	780 to 1400	780 to 1400
Rating (A)	250	400	630	1000
Polarity	3L + N + PE	3L + N + PE	3L + N + PE	3L + N + PE

KSA100 to 400 DMCL 41A

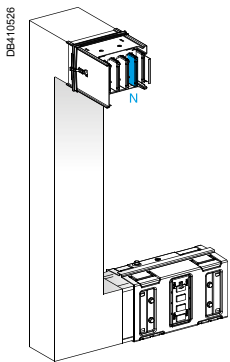

Dimensions				
A (mm)	250	250	290	290
B (mm)	200 to 750	200 to 750	200 to 800	200 to 800
C (mm)	200	200	290	290
D (mm)	-	-	-	-
Fire Barrier	No	No	No	No
Fire Barrier Position	-	-	-	-

KSA500 to 1000 DMCL 41A

Additional Characteristics				
IP	IP55	IP55	IP55	IP55
Color	White	White	White	White
Weight (kg)	-	-	-	-
Selling Unit	1	1	1	1
MOQ	1	1	1	1

A and C dimensions are fixed. B dimension can be adjusted in increments of 5 mm.
 See B minimum and maximum.

To order, indicate for example: KSA400DMCL41A, B = 500

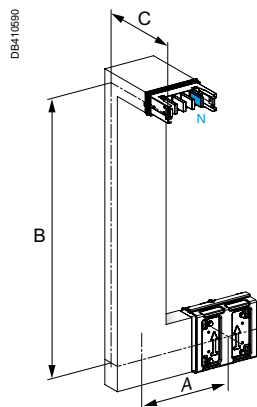

KSA100 to 400 DMCL 41A

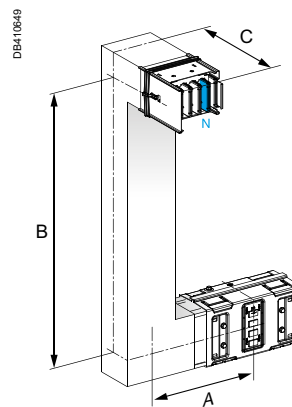

KSA500 to 1000 DMCL 41A

Advanced offer

Change direction elements

Multiples

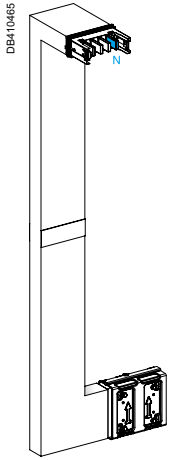

KSA100 to 400 DMCL 41F

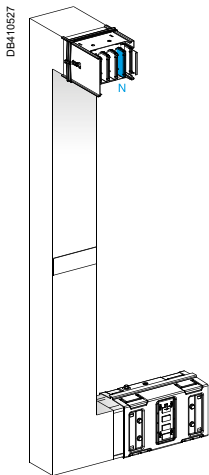

KSA500 to 1000 DMCL 41F

2 turns at 90° - Upward (Edgewise position), then turns left (Flat position)
Sides A and C are fixed, Side B is made-to-measure including a fire Barrier

Cat. n°	KSA250DMCL41F	KSA400DMCL41F	KSA630DMCL41F	KSA1000DMCL41F
Compatible with	KSA100 to 250	KSA400	KSA500 to 1000	KSA500 to 1000
A in the line (mm)	1150 to 1700	1150 to 1700	1280 to 1800	1280 to 1800
Rating (A)	250	400	630	1000
Polarity	3L + N + PE	3L + N + PE	3L + N + PE	3L + N + PE

Dimensions				
A (mm)	250	250	290	290
B (mm)	700 to 1200	700 to 1200	700 to 1200	700 to 1200
C (mm)	200	200	290	290
D (mm)	-	-	-	-
Fire Barrier	Yes	Yes	Yes	Yes
Fire Barrier Position	On side B	On side B	On side B	On side B

Additional Characteristics				
IP	IP55	IP55	IP55	IP55
Color	White	White	White	White
Weight (kg)	-	-	-	-
Selling Unit	1	1	1	1
MOQ	1	1	1	1

A and C dimensions are fixed. B dimension can be adjusted in increments of 5 mm.
 See B minimum and maximum. Fire barrier position on side B is adjustable in increments of 10 mm respecting the Xb and Yb minimum.
 To order, indicate for example: KSA400DMCL41F, B = 900, Xb = 500, Yb = 400

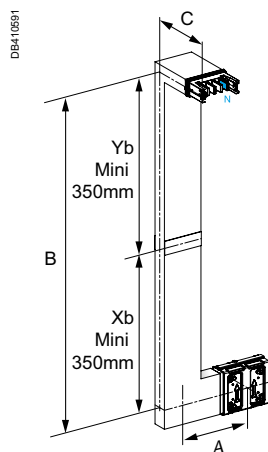

KSA100 to 400 DMCL 41F

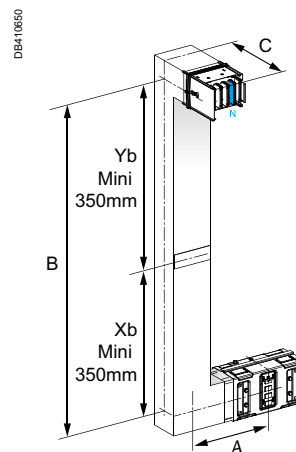

KSA500 to 1000 DMCL 41F

Advanced offer

Change direction elements

Multiples

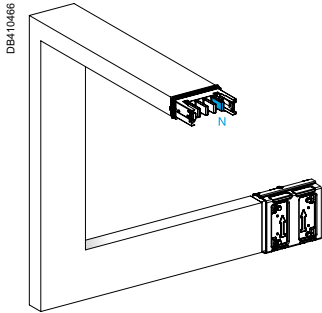

KSA100 to 400 DMCL 43A

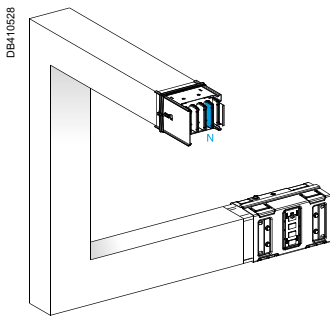

KSA500 to 1000 DMCL 43A

2 turns at 90° - Upward (Edgewise position), then turns left (Flat position)
Sides A, B, C are made-to-measure

Cat. n°	KSA250DMCL43A	KSA400DMCL43A	KSA630DMCL43A	KSA1000DMCL43A
Compatible with	KSA100 to 250	KSA400	KSA500 to 1000	KSA500 to 1000
A in the line (mm)	650 to 2250	650 to 2250	780 to 2400	780 to 2400
Rating (A)	250	400	630	1000
Polarity	3L + N + PE	3L + N + PE	3L + N + PE	3L + N + PE

Dimensions				
A (mm)	250 to 750	250 to 750	290 to 800	290 to 800
B (mm)	200 to 750	200 to 750	200 to 800	200 to 800
C (mm)	200 to 750	200 to 750	290 to 800	290 to 800
D (mm)	-	-	-	-
Fire Barrier	No	No	No	No
Fire Barrier Position	-	-	-	-

Additional Characteristics				
IP	IP55	IP55	IP55	IP55
Color	White	White	White	White
Weight (kg)	-	-	-	-
Selling Unit	1	1	1	1
MOQ	1	1	1	1

A, B and C dimensions can be adjusted in increments of 5 mm. See A,B and C minimum and maximum.

To order, indicate for example: KSA400DMCL43A, A = 400, B = 500, C = 600

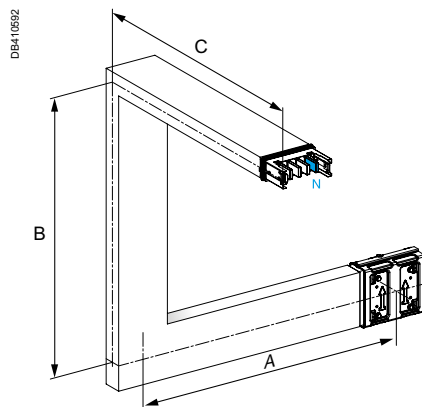

KSA100 to 400 DMCL 43A

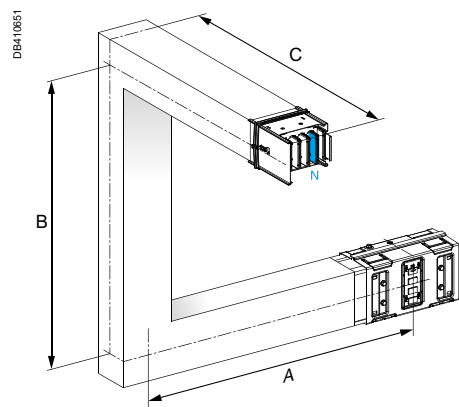

KSA500 to 1000 DMCL 43A

Advanced offer

Change direction elements

Multiples

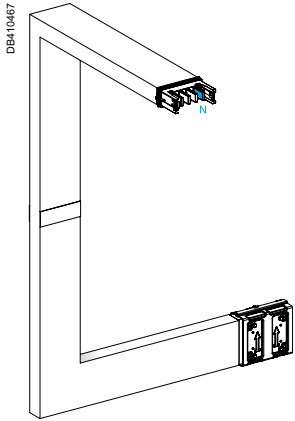

KSA100 to 400 DMCL 43F

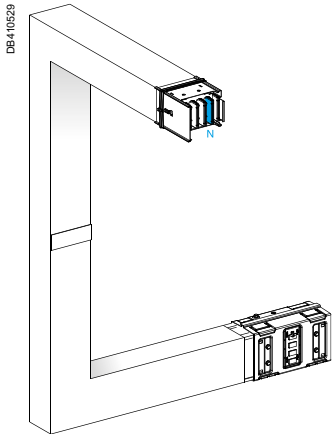

KSA500 to 1000 DMCL 43F

2 turns at 90° - Upward (Edgewise position), then turns left (Flat position)
Sides A, B, C are made-to-measure including 1 fire Barrier on 1 branche

Cat. n°	KSA250DMCL43F	KSA400DMCL43F	KSA630DMCL43F	KSA1000DMCL43F
Compatible with	KSA100 to 250	KSA400	KSA500 to 1000	KSA500 to 1000
A in the line (mm)	1150 to 2700	1150 to 2700	1280 to 2800	1280 to 2800
Rating (A)	250	400	630	1000
Polarity	3L + N + PE	3L + N + PE	3L + N + PE	3L + N + PE

Dimensions				
A (mm)	(250 to 750) or (700 to 1200) if FB	(250 to 750) or (700 to 1200) if FB	(290 to 800) or (700 to 1200) if FB	(290 to 800) or (700 to 1200) if FB
B (mm)	(200 to 750) or (700 to 1200) if FB	(200 to 750) or (700 to 1200) if FB	(200 to 800) or (700 to 1200) if FB	(200 to 800) or (700 to 1200) if FB
C (mm)	(200 to 750) or (700 to 1200) if FB	(200 to 750) or (700 to 1200) if FB	(290 to 800) or (700 to 1200) if FB	(290 to 800) or (700 to 1200) if FB
D (mm)	-	-	-	-
Fire Barrier	Yes	Yes	Yes	Yes
Fire Barrier Position	Either on side A or B or C	Either on side A or B or C	Either on side A or B or C	Either on side A or B or C

Additional Characteristics				
IP	IP55	IP55	IP55	IP55
Color	White	White	White	White
Weight (kg)	-	-	-	-
Selling Unit	1	1	1	1
MOQ	1	1	1	1

A, B and C dimensions can be adjusted in increments of 5 mm. See A, B and C minimum and maximum. One Fire barrier can be positioned either on side A, B or C. Fire barrier position is adjustable in increments of 10 mm respecting the minimum.

To order, indicate for example: KSA400DMCL43F, A = 400, B = 900, Xb = 450, Yb = 450, C = 600

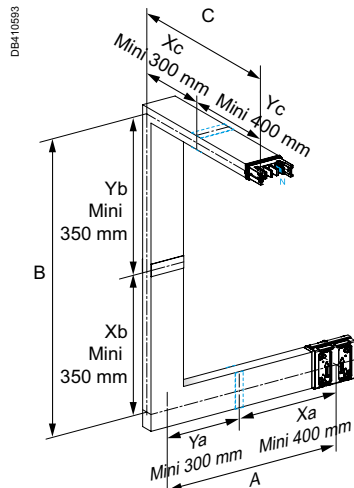

KSA100 to 400 DMCL 43F

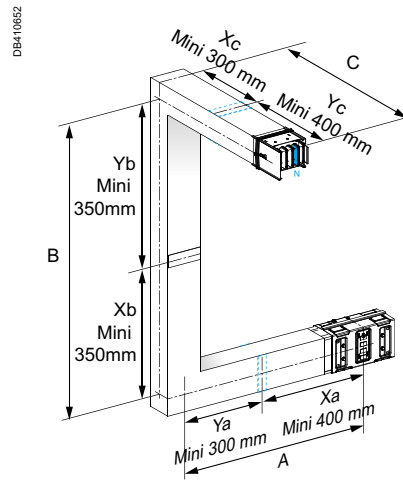

KSA500 to 1000 DMCL 43F

Advanced offer

Change direction elements

Multiples

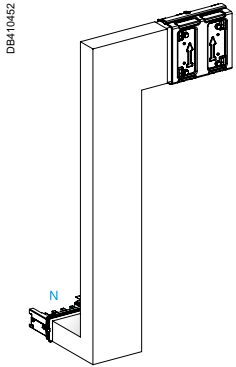

KSA100 to 400 DMBK 41A

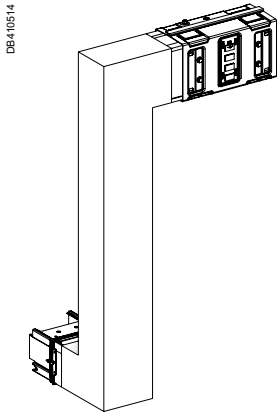

KSA500 to 1000 DMBK 41A

2 turns at 90° - Downward (Edgewise position), then turns right (Flat position)
Sides A and C are fixed, Side B is made-to-measure

Cat. n°	KSA250DMBK41A	KSA400DMBK41A	KSA630DMBK41A	KSA1000DMBK41A
Compatible with	KSA100 to 250	KSA400	KSA500 to 1000	KSA500 to 1000
A in the line (mm)	650 to 1250	650 to 1250	780 to 1400	780 to 1400
Rating (A)	250	400	630	1000
Polarity	3L + N + PE	3L + N + PE	3L + N + PE	3L + N + PE

Dimensions				
A (mm)	250	250	290	290
B (mm)	200 to 750	200 to 750	200 to 800	200 to 800
C (mm)	200	200	290	290
D (mm)	-	-	-	-
Fire Barrier	No	No	No	No
Fire Barrier Position	-	-	-	-

Additional Characteristics				
IP	IP55	IP55	IP55	IP55
Color	White	White	White	White
Weight (kg)	-	-	-	-
Selling Unit	1	1	1	1
MOQ	1	1	1	1

A and C dimensions are fixed. B dimension can be adjusted in increments of 5 mm. See B minimum and maximum.

To order, indicate for example: KSA400DMBK41A, B = 500

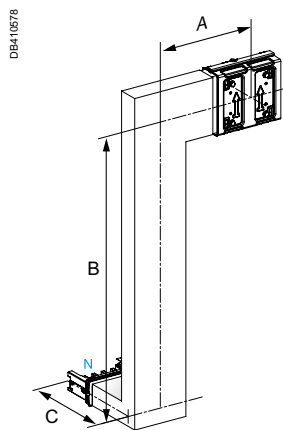

KSA100 to 400 DMBK 41A

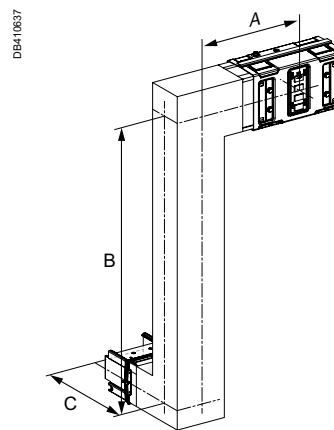

KSA500 to 1000 DMBK 41A

Advanced offer

Change direction elements

Multiples

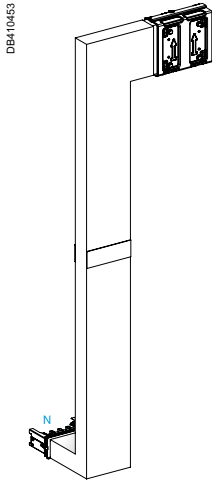

KSA100 to 400 DMBK 41F

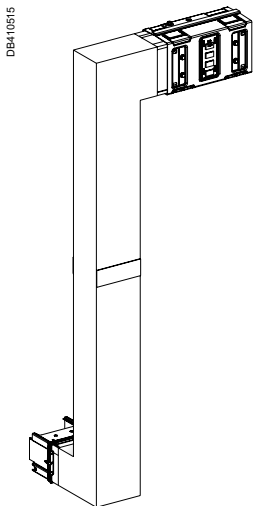

KSA500 to 1000 DMBK 41F

2 turns at 90° - Downward (Edgewise position), then turns right (Flat position)
Sides A and C are fixed, Side B is made-to-measure including a fire Barrier

Cat. n°	KSA250DMBK41F	KSA400DMBK41F	KSA630DMBK41F	KSA1000DMBK41F
Compatible with	KSA100 to 250	KSA400	KSA500 to 1000	KSA500 to 1000
A in the line (mm)	1150 to 1700	1150 to 1700	1280 to 1800	1280 to 1800
Rating (A)	250	400	630	1000
Polarity	3L + N + PE	3L + N + PE	3L + N + PE	3L + N + PE

Dimensions				
A (mm)	250	250	290	290
B (mm)	700 to 1200	700 to 1200	700 to 1200	700 to 1200
C (mm)	200	200	290	290
D (mm)	-	-	-	-
Fire Barrier	Yes	Yes	Yes	Yes
Fire Barrier Position	On side B	On side B	On side B	On side B

Additional Characteristics				
IP	IP55	IP55	IP55	IP55
Color	White	White	White	White
Weight (kg)	-	-	-	-
Selling Unit	1	1	1	1
MOQ	1	1	1	1

A and C dimensions are fixed. B dimension can be adjusted in increments of 5 mm.
 See B minimum and maximum. Fire barrier position on side B is adjustable in increments of 10 mm respecting the Xb and Yb minimum.
 To order, indicate for example: KSA400DMBK41F, B = 900, Xb = 500, Yb = 400

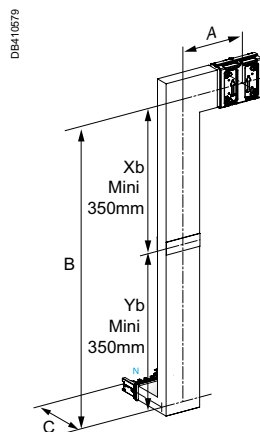

KSA100 to 400 DMBK 41F

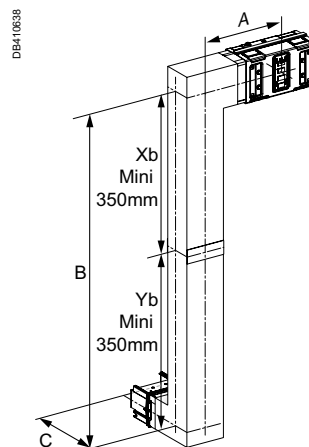

KSA500 to 1000 DMBK 41F

Advanced offer

Change direction elements

Multiples

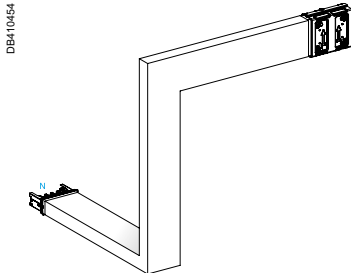

2 turns at 90° - Downward (Edgewise position), then turns right (Flat position)
Sides A, B, C are made-to-measure

Cat. n°	KSA250DMBK43A	KSA400DMBK43A	KSA630DMBK43A	KSA1000DMBK43A
Compatible with	KSA100 to 250	KSA400	KSA500 to 1000	KSA500 to 1000
A in the line (mm)	650 to 2250	650 to 2250	780 to 2400	780 to 2400
Rating (A)	250	400	630	1000
Polarity	3L + N + PE	3L + N + PE	3L + N + PE	3L + N + PE

KSA100 to 400 DMBK 43A

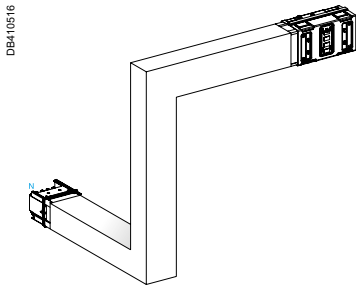

Dimensions				
A (mm)	250 to 750	250 to 750	290 to 800	290 to 800
B (mm)	200 to 750	200 to 750	200 to 800	200 to 800
C (mm)	200 to 750	200 to 750	290 to 800	290 to 800
D (mm)	-	-	-	-
Fire Barrier	No	No	No	No
Fire Barrier Position	-	-	-	-

KSA500 to 1000 DMBK 43A

Additional Characteristics				
IP	IP55	IP55	IP55	IP55
Color	White	White	White	White
Weight (kg)	-	-	-	-
Selling Unit	1	1	1	1
MOQ	1	1	1	1

A, B and C dimensions can be adjusted in increments of 5 mm. See A,B and C minimum and maximum.

To order, indicate for example: KSA400DMBK43A, A = 400, B = 500, C = 600

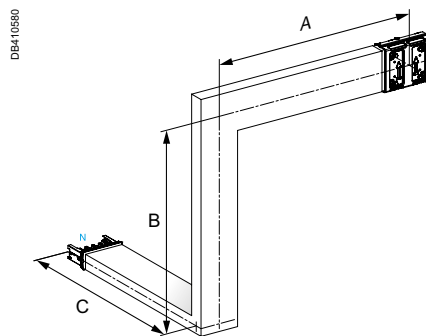

KSA100 to 400 DMBK 43A

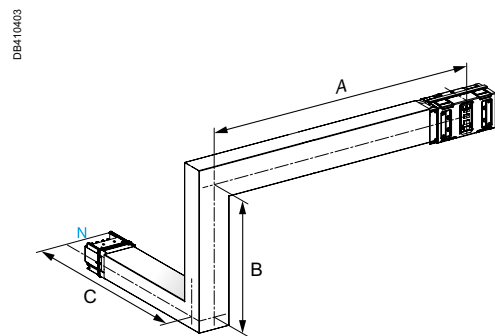

KSA500 to 1000 DMBK 43A

Advanced offer

Change direction elements

Multiples

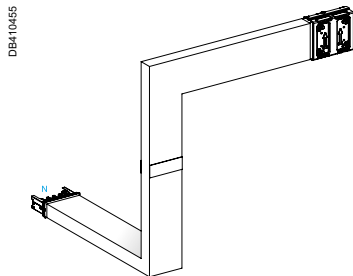

2 turns at 90° - Downward (Edgewise position), then turns right (Flat position)
Sides A, B, C are made-to-measure including 1 fire Barrier on 1 branche

Cat. n°	KSA250DMBK43F	KSA400DMBK43F	KSA630DMBK43F	KSA1000DMBK43F
Compatible with	KSA100 to 250	KSA400	KSA500 to 1000	KSA500 to 1000
A in the line (mm)	1150 to 2700	1150 to 2700	1280 to 2800	1280 to 2800
Rating (A)	250	400	630	1000
Polarity	3L + N + PE	3L + N + PE	3L + N + PE	3L + N + PE

KSA100 to 400 DMBK 43F

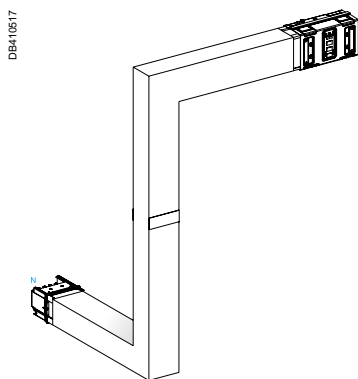

Dimensions				
A (mm)	(250 to 750) or (700 to 1200) if FB	(250 to 750) or (700 to 1200) if FB	(290 to 800) or (700 to 1200) if FB	(290 to 800) or (700 to 1200) if FB
B (mm)	(200 to 750) or (700 to 1200) if FB	(200 to 750) or (700 to 1200) if FB	(200 to 800) or (700 to 1200) if FB	(200 to 800) or (700 to 1200) if FB
C (mm)	(200 to 750) or (700 to 1200) if FB	(200 to 750) or (700 to 1200) if FB	(290 to 800) or (700 to 1200) if FB	(290 to 800) or (700 to 1200) if FB
D (mm)	-	-	-	-
Fire Barrier	Yes	Yes	Yes	Yes
Fire Barrier Position	Either on side A or B or C	Either on side A or B or C	Either on side A or B or C	Either on side A or B or C

KSA500 to 1000 DMBK 43F



Additional Characteristics				
IP	IP55	IP55	IP55	IP55
Color	White	White	White	White
Weight (kg)	-	-	-	-
Selling Unit	1	1	1	1
MOQ	1	1	1	1

A, B and C dimensions can be adjusted in increments of 5 mm. See A,B and C minimum and maximum. One Fire barrier can be positioned either on side A, B or C. Fire barrier position is adjustable in increments of 10 mm respecting the X and Y minimum.

To order, indicate for example: KSA400DMBK43F, A = 400, B = 900, Xb = 450, Yb = 450, C = 600

DB410581

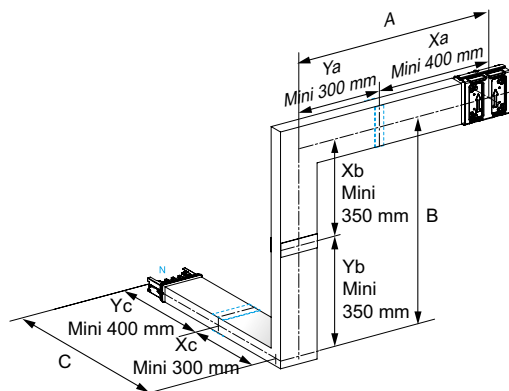

KSA100 to 400 DMBK 43F

DB410640

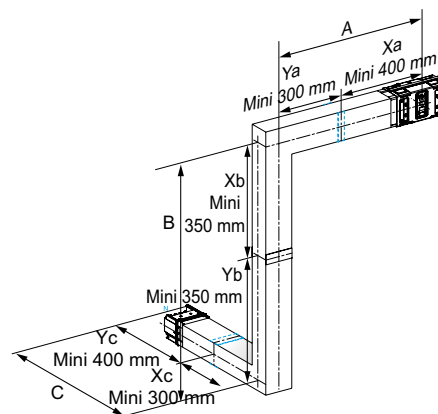

KSA500 to 1000 DMBK 43F

Advanced offer

Change direction elements

Multiples

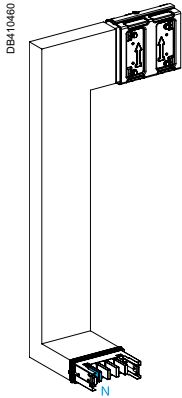

KSA100 to 400 DMCK 41A

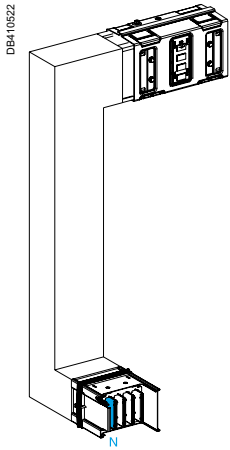

KSA500 to 1000 DMCK 41A

2 turns at 90° - Downward (Edgewise position), then turns left (Flat position)
Sides A and C are fixed, Side B is made-to-measure

Cat. n°	KSA250DMCK41A	KSA400DMCK41A	KSA630DMCK41A	KSA1000DMCK41A
Compatible with	KSA100 to 250	KSA400	KSA500 to 1000	KSA500 to 1000
A in the line (mm)	650 to 1250	650 to 1250	780 to 1400	780 to 1400
Rating (A)	250	400	630	1000
Polarity	3L + N + PE	3L + N + PE	3L + N + PE	3L + N + PE

Dimensions				
A (mm)	250	250	290	290
B (mm)	200 to 750	200 to 750	200 to 800	200 to 800
C (mm)	200	200	290	290
D (mm)	-	-	-	-
Fire Barrier	No	No	No	No
Fire Barrier Position	-	-	-	-

Additional Characteristics				
IP	IP55	IP55	IP55	IP55
Color	White	White	White	White
Weight (kg)	-	-	-	-
Selling Unit	1	1	1	1
MOQ	1	1	1	1

A and C dimensions are fixed. B dimension can be adjusted in increments of 5 mm. See B minimum and maximum.

To order, indicate for example: KSA400DMCK41A, B = 500

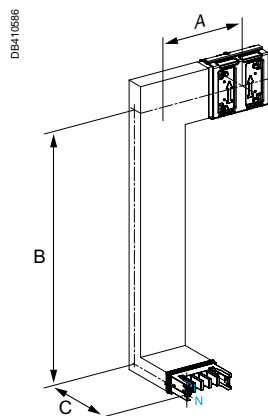

KSA100 to 400 DMCK 41A

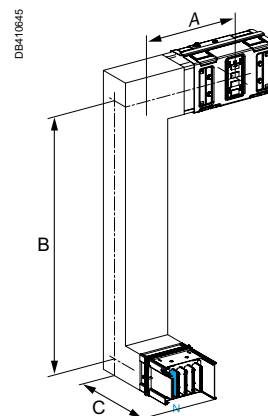

KSA500 to 1000 DMCK 41A

Advanced offer

Change direction elements

Multiples

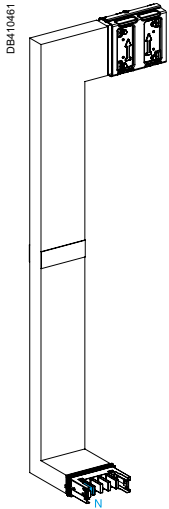

KSA100 to 400 DMCK 41F

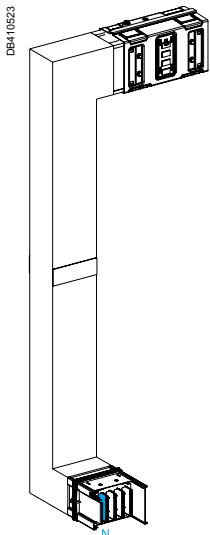

KSA500 to 1000 DMCK 41F

2 turns at 90° - Downward (Edgewise position), then turns left (Flat position)
Sides A and C are fixed, Side B is made-to-measure including a fire Barrier

Cat. n°	KSA250DMCK41F	KSA400DMCK41F	KSA630DMCK41F	KSA1000DMCK41F
Compatible with	KSA100 to 250	KSA400	KSA500 to 1000	KSA500 to 1000
A in the line (mm)	1150 to 1700	1150 to 1700	1280 to 1800	1280 to 1800
Rating (A)	250	400	630	1000
Polarity	3L + N + PE	3L + N + PE	3L + N + PE	3L + N + PE

Dimensions				
A (mm)	250	250	290	290
B (mm)	700 to 1200	700 to 1200	700 to 1200	700 to 1200
C (mm)	200	200	290	290
D (mm)	-	-	-	-
Fire Barrier	Yes	Yes	Yes	Yes
Fire Barrier Position	On side B	On side B	On side B	On side B

Additional Characteristics				
IP	IP55	IP55	IP55	IP55
Color	White	White	White	White
Weight (kg)	-	-	-	-
Selling Unit	1	1	1	1
MOQ	1	1	1	1

A and C dimensions are fixed. B dimension can be adjusted in increments of 5 mm. See B minimum and maximum. Fire barrier position on side B is adjustable in increments of 10 mm respecting the Xb and Yb minimum.

To order, indicate for example: KSA400DMCK41F, B = 900, Xb = 500, Yb = 400

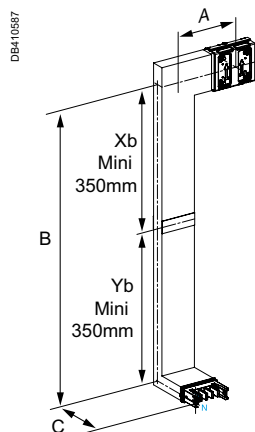

KSA100 to 400 DMCK 41F

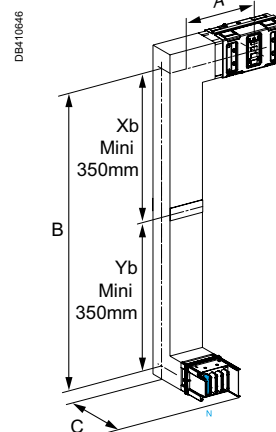

KSA500 to 1000 DMCK 41F



Advanced offer

Change direction elements

Multiples

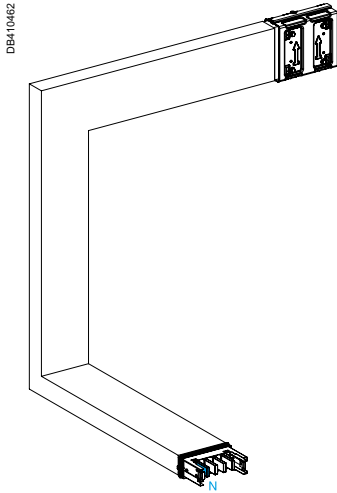

KSA100 to 400 DMCK 43A

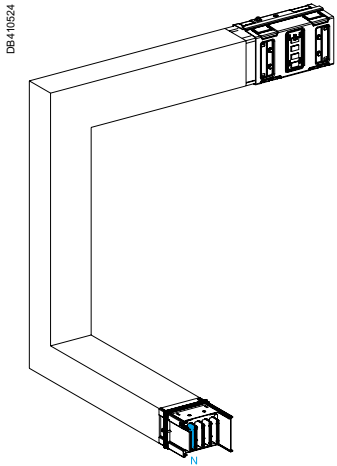

KSA500 to 1000 DMCK 43A

2 turns at 90° - Downward (Edgewise position), then turns left (Flat position)
Sides A, B, C are made-to-measure

Cat. n°	KSA250DMCK43A	KSA400DMCK43A	KSA630DMCK43A	KSA1000DMCK43A
Compatible with	KSA100 to 250	KSA400	KSA500 to 1000	KSA500 to 1000
A in the line (mm)	650 to 2250	650 to 2250	780 to 2400	780 to 2400
Rating (A)	250	400	630	1000
Polarity	3L + N + PE	3L + N + PE	3L + N + PE	3L + N + PE

Dimensions				
A (mm)	250 to 750	250 to 750	290 to 800	290 to 800
B (mm)	200 to 750	200 to 750	200 to 800	200 to 800
C (mm)	200 to 750	200 to 750	290 to 800	290 to 800
D (mm)	-	-	-	-
Fire Barrier	No	No	No	No
Fire Barrier Position	-	-	-	-

Additional Characteristics				
IP	IP55	IP55	IP55	IP55
Color	White	White	White	White
Weight (kg)	-	-	-	-
Selling Unit	1	1	1	1
MOQ	1	1	1	1

A, B and C dimensions can be adjusted in increments of 5 mm. See A,B and C minimum and maximum.

To order, indicate for example: KSA400DMCK43A, A = 400, B = 500, C = 600

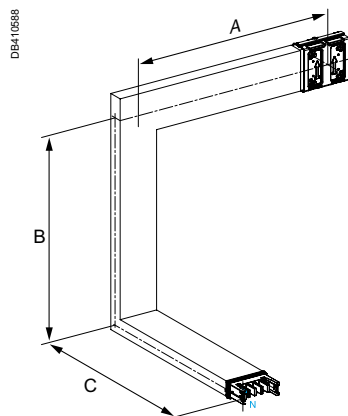

KSA100 to 400 DMCK 43A

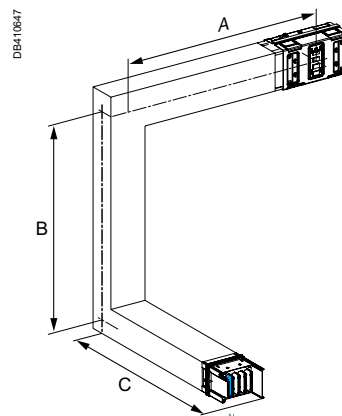

KSA500 to 1000 DMCK 43A

Advanced offer

Change direction elements

Multiples



KSA100 to 400 DMCK 43F

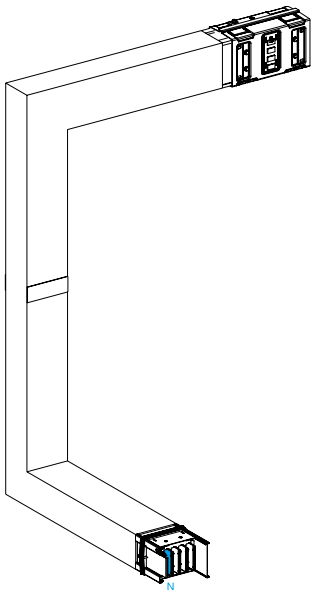

KSA500 to 1000 DMCK 43F

2 turns at 90° - Downward (Edgewise position), then turns left (Flat position)
Sides A, B, C are made-to-measure including 1 fire Barrier on 1 branche

Cat. n°	KSA250DMCK43F	KSA400DMCK43F	KSA630DMCK43F	KSA1000DMCK43F
Compatible with	KSA100 to 250	KSA400	KSA500 to 1000	KSA500 to 1000
A in the line (mm)	1150 to 2700	1150 to 2700	1280 to 2800	1280 to 2800
Rating (A)	250	400	630	1000
Polarity	3L + N + PE	3L + N + PE	3L + N + PE	3L + N + PE

Dimensions

A (mm)	(250 to 750) or (700 to 1200) if FB	(250 to 750) or (700 to 1200) if FB	(290 to 800) or (700 to 1200) if FB	(290 to 800) or (700 to 1200) if FB
B (mm)	(200 to 750) or (700 to 1200) if FB	(200 to 750) or (700 to 1200) if FB	(200 to 800) or (700 to 1200) if FB	(200 to 800) or (700 to 1200) if FB
C (mm)	(200 to 750) or (700 to 1200) if FB	(200 to 750) or (700 to 1200) if FB	(290 to 800) or (700 to 1200) if FB	(290 to 800) or (700 to 1200) if FB
D (mm)	-	-	-	-
Fire Barrier	Yes	Yes	Yes	Yes
Fire Barrier Position	Either on side A or B or C	Either on side A or B or C	Either on side A or B or C	Either on side A or B or C

Additional Characteristics

IP	IP55	IP55	IP55	IP55
Color	White	White	White	White
Weight (kg)	-	-	-	-
Selling Unit	1	1	1	1
MOQ	1	1	1	1

A, B and C dimensions can be adjusted in increments of 5 mm. See A, B and C minimum and maximum. One Fire barrier can be positioned either on side A, B or C. Fire barrier position is adjustable in increments of 10 mm respecting the X and Y minimum.

To order, indicate for example: KSA400DMCK43F, A = 400, B = 900, Xb = 450, Yb = 450, C = 600

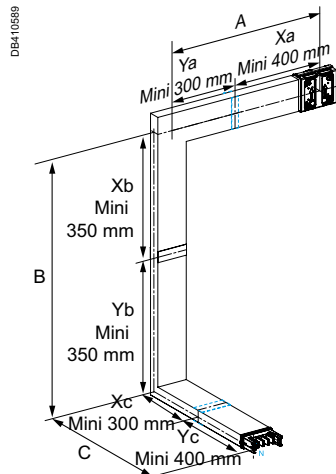

KSA100 to 400 DMCK 43F

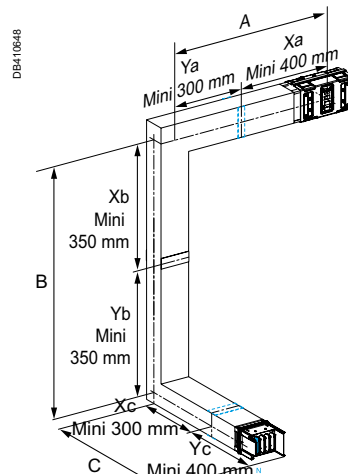

KSA500 to 1000 DMCK 43F

Advanced offer

Change direction elements

Tees and Crosses

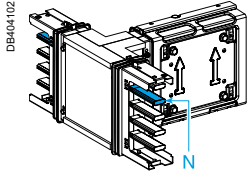

KSA100 to 400 DTC 40

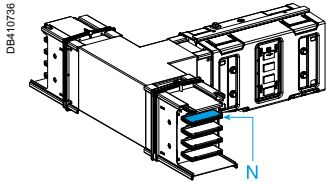

KSA500 to 1000 DTC 40

To connect several lines together
To connect 3 lines

Cat. n°	KSA250DTC40	KSA400DTC40	KSA630DTC40	KSA1000DTC40
Compatible with	KSA100 to 250	KSA400	KSA500 to 1000	KSA500 to 1000
A in the line (mm)	330	330	580	580
Rating (A)	250	400	630	1000
Polarity	3L + N + PE	3L + N + PE	3L + N + PE	3L + N + PE

Dimensions				
A (mm)	165	165	290	290
B (mm)	165	165	290	290
C (mm)	165	165	290	290
D (mm)	-	-	-	-
Fire Barrier	No	No	No	No
Fire Barrier Position	-	-	-	-

Additional Characteristics				
IP	IP55	IP55	IP55	IP55
Color	White	White	White	White
Weight (kg)	4,3	4,7	10	10
Selling Unit	1	1	1	1
MOQ	1	1	1	1

A, B and C dimensions are fixed. Supplied without End covers

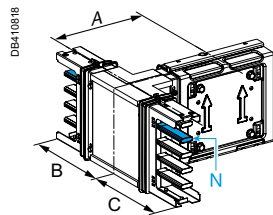

KSA100 to 400 DTC 40

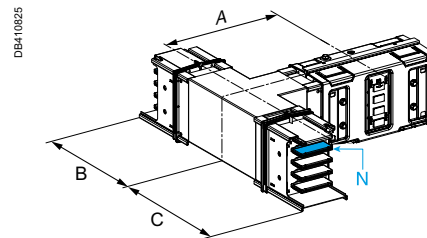

KSA500 to 1000 DTC 40

Advanced offer

Change direction elements

Tees and Crosses

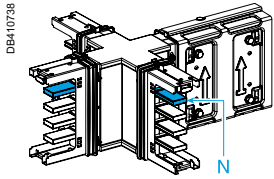

KSA100 to 400 DXC 40

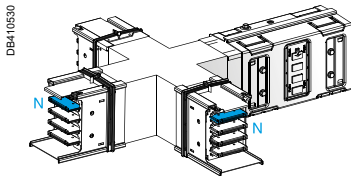

KSA500 to 1000 DXC 40

To connect several lines together
To connect 4 lines

Cat. n°	KSA250DXC40	KSA400DXC40	KSA630DXC40	KSA1000DXC40
Compatible with	KSA100 to 250	KSA400	KSA500 to 1000	KSA500 to 1000
A in the line (mm)	330	330	580	580
Rating (A)	250	400	630	1000
Polarity	3L + N + PE	3L + N + PE	3L + N + PE	3L + N + PE

Dimensions				
A (mm)	165	165	290	290
B (mm)	165	165	290	290
C (mm)	165	165	290	290
D (mm)	165	165	290	290
Fire Barrier	No	No	No	No
Fire Barrier Position	-	-	-	-

Additional Characteristics				
IP	IP55	IP55	IP55	IP55
Color	White	White	White	White
Weight (kg)	4,5	7	11	11,5
Selling Unit	1	1	1	1
MOQ	1	1	1	1

A, B and C dimensions are fixed. Supplied without End covers

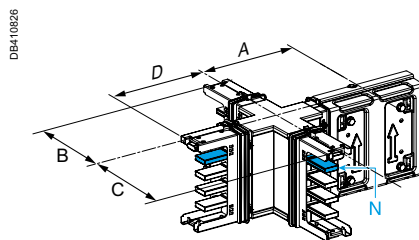

KSA100 to 400 DXC 40

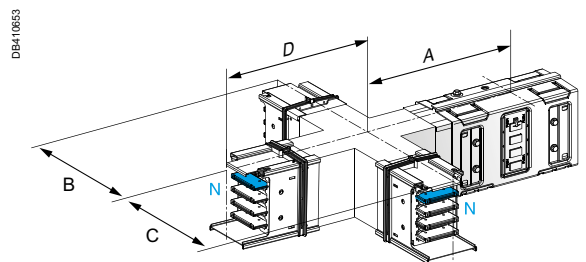

KSA500 to 1000 DXC 40



Advanced offer

Connectors and Tap-off units

Disconnection by opening the door

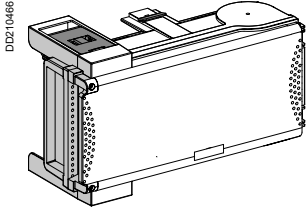

KSB50 SV •

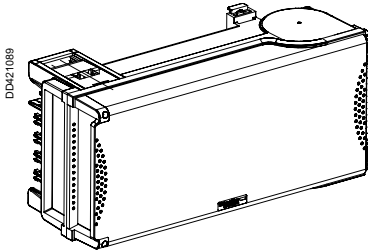

KSB100 SV •

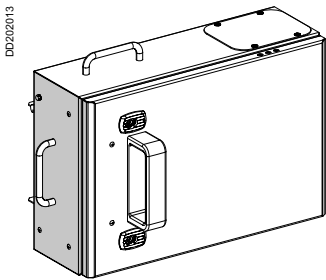

KSB160 SV •

Delivered with an Isolator, without protection nor routing plate
To be customized

Cat. n°	KSB50SV4	KSB100SV4	KSB160SV4
Compatible with	KSA100 to 1000	KSA100 to 1000	KSA100 to 1000

Rating (A)	50	100	160
Polarity	3L + N + PE	3L + N + PE	3L + N + PE
Phase Diagram			

Cabling			
Protection Type (Not Supplied)	None - to be selected by the customer	None - to be selected by the customer	None - to be selected by the customer
Body Material	Plastic	Plastic	Metal
Cable Output	Cable gland ⁽²⁾	Cable gland ⁽²⁾	2 lateral 1.5mm steel cable plates 245 x 115
Available Area (mm)	2 x ISO 50 for multipolar cable	2 x ISO 63 for multipolar cable	2 x (215 x 185)
Connection	Silver-plated copper terminals (M6) for Copper compression lugs	Silver-plated copper terminals (M6) for Copper compression lugs	Silver-plated copper terminals (M6) for Copper compression lugs
Maximum Rigid Cable Size (mm ²)	25	35	70
Maximum Flexible Cable Size (mm ²)	25	35	70

⁽²⁾ Not included ⁽²⁾ Not included -

Additional Characteristics			
IP	IP55	IP55	IP55
Color	White	White	White
Weight (kg)	1,4	2,8	9
Selling Unit	1	1	1
MOQ	1	1	1

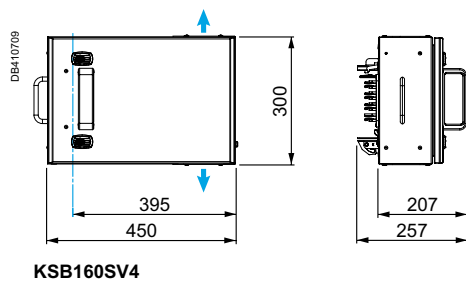
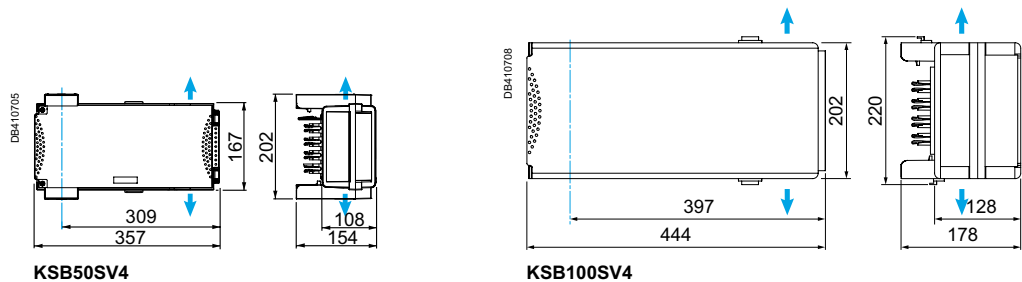

Advanced offer

Connectors and Tap-off units

Disconnection by opening the door

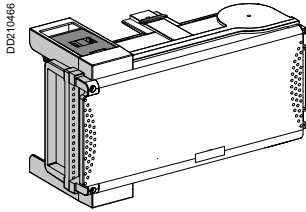

KSB50 SV •

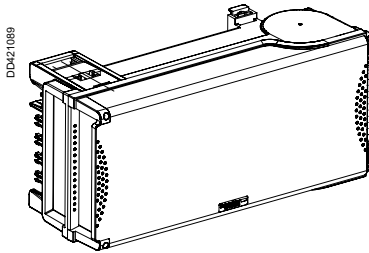

KSB100 SV •

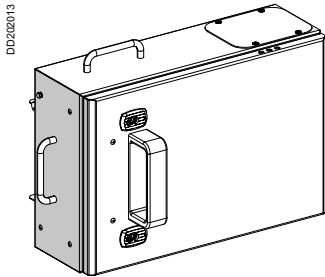

KSB160 SV •

Delivered with an Isolator, without protection nor mounting plate
To be customized

Cat. n°	KSB50SV5	KSB100SV5	KSB160SV5
Compatible with	KSA100 to 1000	KSA100 to 1000	KSA100 to 1000

Rating (A)	50	100	160
Polarity	3L + PEN	3L + PEN	3L + PEN
Phase Diagram			

Cabling			
Protection Type (Not Supplied)	None - to be selected by the customer	None - to be selected by the customer	None - to be selected by the customer
Body Material	Plastic	Plastic	Metal
Cable Output	Cable gland ⁽²⁾	Cable gland ⁽²⁾	2 lateral 1.5mm steel cable plates 245 x 115
Available Area (mm)	2 x ISO 50 for multipolar cable	2 x ISO 63 for multipolar cable	2 x (215 x 185)
Connection	Silver-plated copper terminals (M6) for Copper compression lugs	Silver-plated copper terminals (M6) for Copper compression lugs	Silver-plated copper terminals (M6) for Copper compression lugs
Maximum Rigid Cable Size (mm ²)	25	35	70
Maximum Flexible Cable Size (mm ²)	25	35	70

⁽²⁾ Not included ⁽²⁾ Not included -

Additional Characteristics			
IP	IP55	IP55	IP55
Color	White	White	White
Weight (kg)	1,4	2,8	9
Selling Unit	1	1	1
MOQ	1	1	1

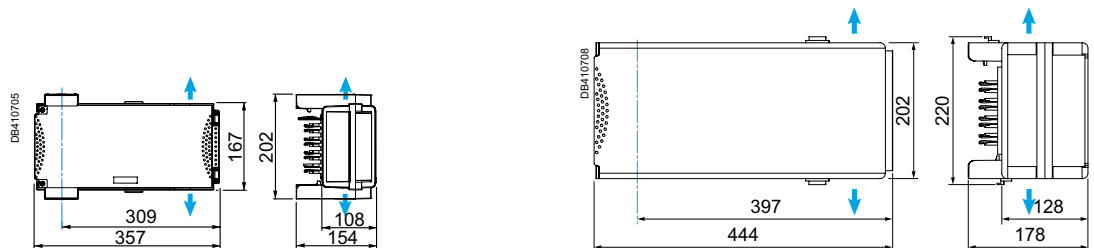

KSB50 SV •

KSB100 SV •

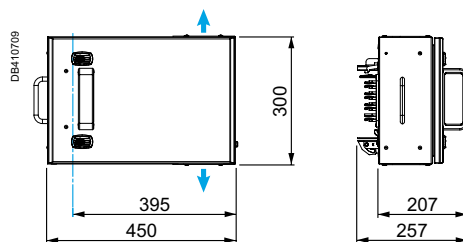

KSB160 SV •



Advanced offer

Connectors and Tap-off units

Disconnection by opening the door

DB410551

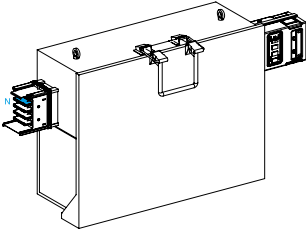

KSB630 SE •

**Delivered equipped with a fuse holder
For Blade-type fuses ⁽¹⁾**

Cat. n°	KSB630SE4	KSB630SE5
Compatible with	KSA500 to 1000	KSA500 to 1000

Rating (A)	630	630
Polarity	3L + N + PE	3L + PEN
Phase Diagram		

Cabling		
Protection Type (Not Supplied)	Fuses Size 3	Fuses Size 3

Body Material	Metal	Metal
Cable Output	2 lateral 3mm Alu. Cable plates 300 x 252	2 lateral 3mm Alu. Cable plates 300 x 252

Available Area (mm)	250 x 180	250 x 180
----------------------------	-----------	-----------

Connection	Copper plate with 2 x M10 for Copper compression lugs	Copper plate with 2 x M10 for Copper compression lugs
-------------------	---	---

Maximum Rigid Cable Size (mm²)	2 x 240 mm ²	2 x 240 mm ²
--	-------------------------	-------------------------

Maximum Flexible Cable Size (mm²)	2 x 240 mm ²	2 x 240 mm ²
---	-------------------------	-------------------------

⁽¹⁾ Not included ⁽¹⁾ Not included

Additional Characteristics

IP	IP55	IP55
Color	White	White
Weight (kg)	55	57
Selling Unit	1	1
MOQ	1	1

Supplied with 2 end covers and a jointing unit 800/1000A.

Rating: apply a derating coefficient of 0.9

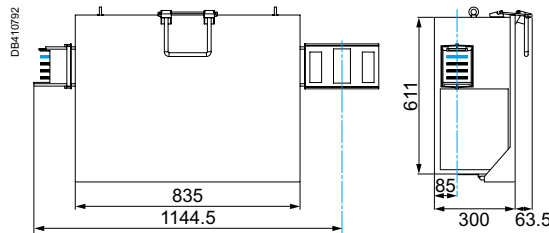

KSB630 SE •

Advanced offer

Connectors and Tap-off units

Switching with an extended rotary handle located on the door

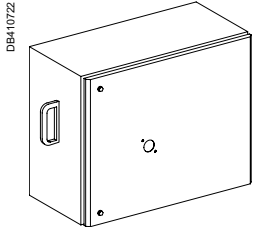

KSB250 SDF •

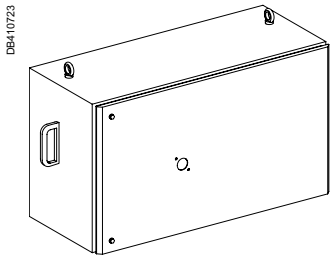

KSB400 SDF •

Delivered equipped with a mounting plate for 1 fuse switch-disconnector
For Fupact INF

Cat. n°	KSB250SDF4	KSB250SDF5	KSB400SDF4	KSB400SDF5
Compatible with	KSA100 to 1000	KSA100 to 1000	KSA500 to 1000	KSA500 to 1000

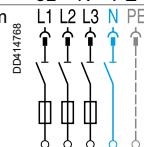
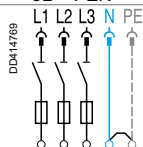
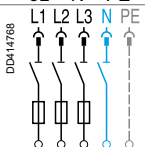
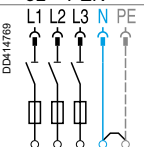
Rating (A)	250	250	400	400
Polarity	3L + N + PE	3L + PEN	3L + N + PE	3L + PEN
Phase Diagram				

Cabling				
Protection Type (Not Supplied)	Fupact INFD250 or INFB250	Fupact INFD250 or INFB250	Fupact INFD400 or INFB400	Fupact INFD400 or INFB400

Body Material	Metal	Metal	Metal	Metal
Cable Output	1 rear 1.5 mm steel cable plate 245 x 130	1 rear 1.5 mm steel cable plate 245 x 130	1 rear 1.5 mm steel cable plate 345 x 130	1 rear 1.5 mm steel cable plate 345 x 130
Available Area (mm)	215 x 100	215 x 100	315 x 100	315 x 100

Connection	Fupact INF terminals	Fupact INF terminals	Fupact INF terminals	Fupact INF terminals
------------	----------------------	----------------------	----------------------	----------------------

Maximum Rigid Cable Size (mm ²)	See Fupact INF Catalog	See Fupact INF Catalog	See Fupact INF Catalog	See Fupact INF Catalog
Maximum Flexible Cable Size (mm ²)	See Fupact INF catalog	See Fupact INF catalog	See Fupact INF catalog	See Fupact INF catalog

INFB250 4P 3F: LV480518	INFB250 3P 3F: LV480517 + N: LV480562	INFB400 4P 3F: LV480520	INFB400 3P 3F: LV480519 + N: LV480563
INFD250 4P 3F: LV480504	INFD250 3P 3F: LV48050 + N: LV480562	INFD400 4P 3F: LV480507	INFD400 3P 3F: LV480506 + N: LV480563

Additional Characteristics				
IP	IP55	IP55	IP55	IP55
Color	White	White	White	White
Weight (kg)	13	13	20	20
Selling Unit	1	1	1	1
MOQ	1	1	16	1

INF•250: Extended rotary handle 49619

INF•400: Extended rotary handle LV480540

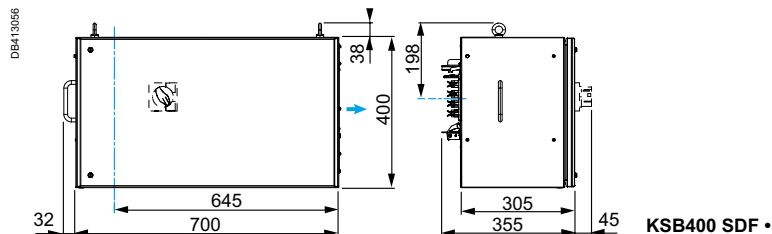
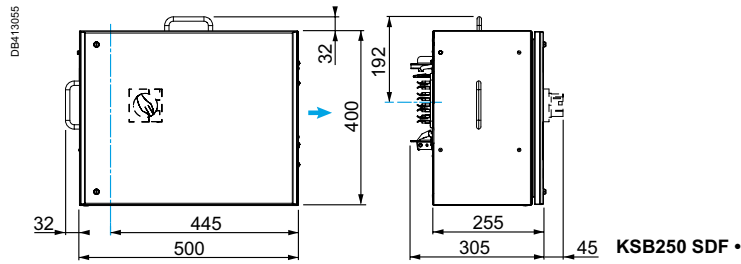

Advanced offer

Connectors and Tap-off units

Switching with an extended rotary handle located on the door

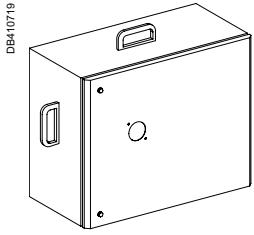

KSB250 DC TRE

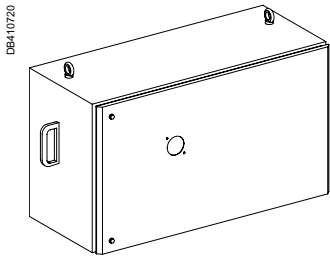

KSB400 DC TRE

Delivered equipped with a mounting plate for 1 Circuit Breaker + 1 Current transformer module
For NSX Circuit breaker + Current transformer module

Cat. n°	KSB250DC4TRE	KSB250DC5TRE	KSB400DC4TRE	KSB400DC5TRE
Compatible with	KSA100 to 1000	KSA100 to 1000	KSA500 to 1000	KSA500 to 1000

Rating (A)	250	250	400	400
Polarity	3L + N + PE	3L + PEN	3L + N + PE	3L + PEN
Phase Diagram				

Cabling				
Protection Type (Not Supplied)	NSX250 - N, H, L	NSX250 - N, H, L	NSX400 - N, H, L	NSX400 - N, H, L

Body Material	Metal	Metal	Metal	Metal
Cable Output	1 rear 1.5mm steel cable plate 245 x 130	1 rear 1.5mm steel cable plate 245 x 130	1 rear 1.5mm steel cable plate 345 x 130	1 rear 1.5mm steel cable plate 345 x 130
Available Area (mm)	215 x 100	215 x 100	315 x 100	315 x 100

Connection	On NSX CT bloc terminals	On NSX CT bloc terminals	On NSX CT bloc terminals	On NSX CT bloc terminals
------------	--------------------------	--------------------------	--------------------------	--------------------------

Maximum Rigid Cable Size (mm ²)	See NSX catalog	See NSX catalog	See NSX catalog	See NSX catalog
Maximum Flexible Cable Size (mm ²)	See NSX catalog	See NSX catalog	See NSX catalog	See NSX catalog

NSX250: Extended rotary handle LV429338	NSX250: Extended rotary handle LV429338	NSX400: Extended rotary handle LV432598	NSX400: Extended rotary handle LV432598
CT Module 4P 250A: LV431568	CT Module 3P 250A: LV431567	CT Module 4P 400A: LV432658	CT Module 4P 400A: LV432657

Additional Characteristics				
IP	IP55	IP55	IP55	IP55
Color	White	White	White	White
Weight (kg)	21	13,5	20	19,5
Selling Unit	1	1	1	1
MOQ	1	1	1	1

Tap-off units equipped with an additional support for the CT module

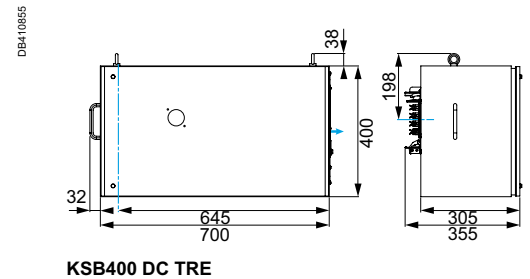
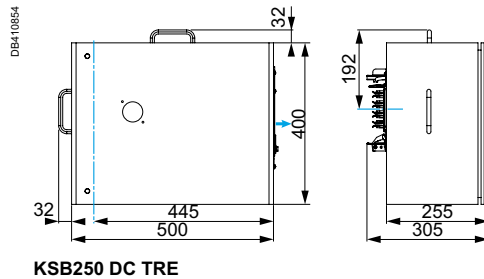

Advanced offer

Connectors and Tap-off units

Switching with an extended rotary handle located on the door

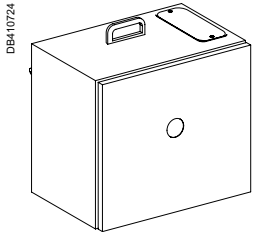

KSB160 DD 4

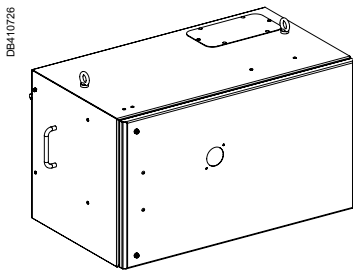

KSB400 DD 4

**Delivered equipped with a plug-in base for 1 Circuit Breaker
For NSX Circuit Breaker PLUG-IN**

Cat. n°	KSB160DD411	KSB400DD411
Compatible with	KSA100 to 1000	KSA500 to 1000
Rating (A)	160	400
Polarity	3L + N + PE	3L + N + PE
Phase Diagram		
Cabling		
Protection Type (Not Supplied)	NSX160 plug-in Curve N, H, L	NSX400 plug-in Curve N, H, L
Body Material	Metal	Metal
Cable Output	2 lateral 1.5 mm FL21 cable gland plates	1 rear 1.5 mm steel cable plate + 2 lateral FL21
Available Area (mm)	2 x FL21 (198 x 69)	315 x 100 + 2 x FL21 (198 x 69)
Connection	NSX Terminals	NSX Terminals
Maximum Rigid Cable Size (mm²)	See NSX catalog	See NSX catalog
Maximum Flexible Cable Size (mm²)	See NSX Catalog	See NSX catalog
	NSX250: Extended rotary handle LV429338	NSX400: Extended rotary handle LV432598

Additional Characteristics		
IP	IP55	IP55
Color	White	White
Weight (kg)	15	23,6
Selling Unit	1	1
MOQ	1	1

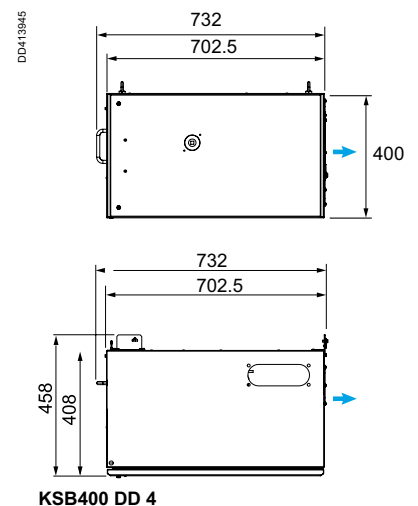
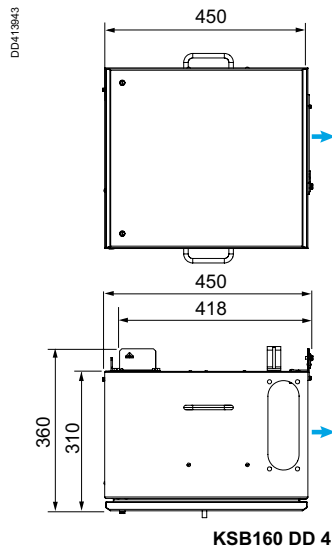

Advanced offer

Connectors and Tap-off units

Disconnection by operating the fuse-switch disconnecter

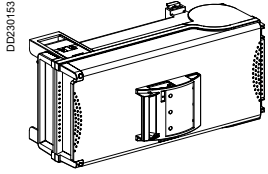

KSB125HD5

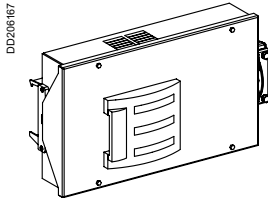

KSA25HD502

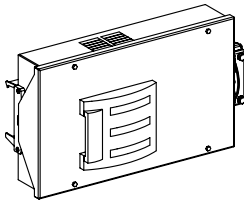

KSA40HD502

**Delivered equipped with a fuse-switch disconnecter
With Fupact ISFT for DIN fuses**

Cat. n°	KSB125HD5	KSA25HD502	KSA40HD502
Compatible with	KSA100 to 1000	KSA100 to 1000	KSA500 to 1000

Rating (A)	125	250	400
Polarity	3L + PEN	3L + PEN	3L + PEN
Phase Diagram			

Cabling			
Protection Type (Not Supplied)	NH2	NH00	NH1

Body Material	Plastic	Metal	Metal
Cable Output	Cable gland ⁽²⁾	-	-

Available Area (mm)	2 x ISO 63 for multipolar cable	-	-
---------------------	---------------------------------	---	---

Connection	Fupact ISFT terminals	Fupact ISFT terminals	Fupact ISFT terminals
------------	-----------------------	-----------------------	-----------------------

Maximum Rigid Cable Size (mm ²)	See ISFT catalog	See ISFT catalog	See ISFT catalog
Maximum Flexible Cable Size (mm ²)	See ISFT catalog	See ISFT catalog	See ISFT catalog

⁽²⁾ Not included

Additional Characteristics

IP	IP20	IP20	IP20
Color	White	White	White
Weight (kg)	3,6	9	12
Selling Unit	1	1	1
MOQ	1	1	1

Available up to end of 2018

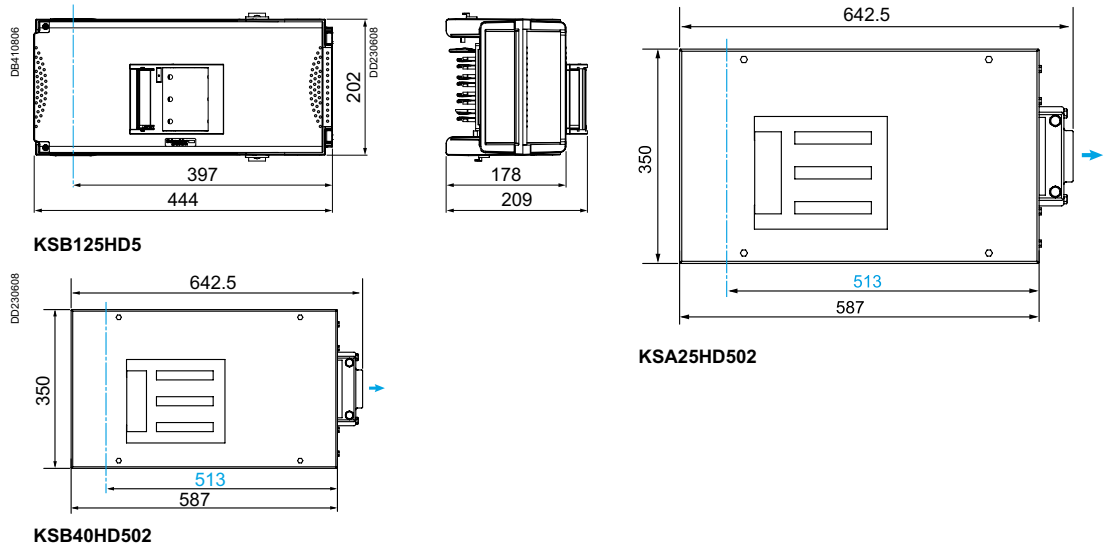

Advanced offer

Connectors and Tap-off units

Disconnection by operating the fuse-switch disconnector

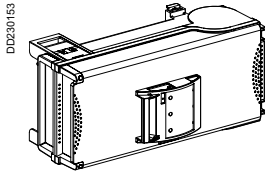

KSB125HD502

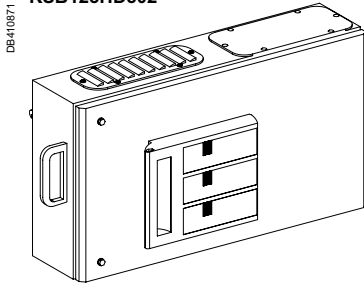

KSB250HD502

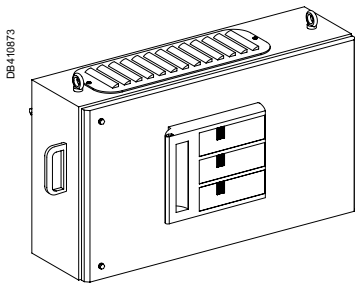

KSB400HD502

Delivered equipped with a fuse-switch disconnector
With Fupact ISFT for DIN fuses

Cat. n°	KSB125HD502	KSB250HD502	KSB400HD502
Compatible with	KSA100 to 1000	KSA100 to 1000	KSA500 to 1000

Rating (A)	125	200	320
Polarity	3L + PEN	3L + PEN	3L + PEN
Phase Diagram			

Cabling			
Protection Type (Not Supplied)	NH2	NH00	NH1

Body Material	Plastic	Metal	Metal
Cable Output	Cable gland ⁽²⁾	-	-

Available Area (mm)	2 x ISO 63 for multipolar cable	-	-
---------------------	---------------------------------	---	---

Connection	Fupact ISFT terminals	Fupact ISFT terminals	Fupact ISFT terminals
------------	-----------------------	-----------------------	-----------------------

Maximum Rigid Cable Size (mm ²)	See ISFT catalog	See ISFT catalog	See ISFT catalog
---	------------------	------------------	------------------

Maximum Flexible Cable Size (mm ²)	See ISFT catalog	See ISFT catalog	See ISFT catalog
--	------------------	------------------	------------------

⁽²⁾ Not included

Additional Characteristics

IP	IP20	IP20	IP20
Color	White	White	White
Weight (kg)	3,6	9	12
Selling Unit	1	1	1
MOQ	1	1	1

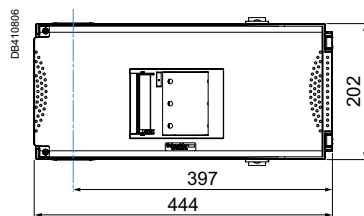

KSB125HD502

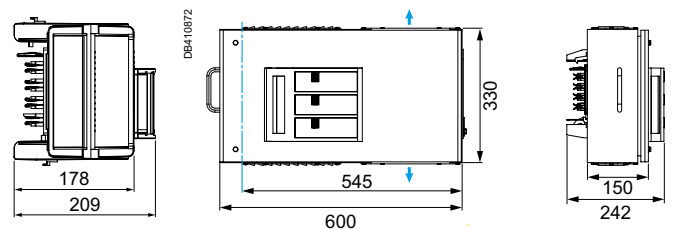

KSB250HD502

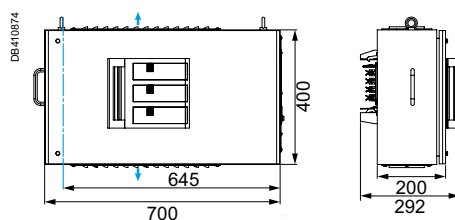

KSA400HD502

Advanced offer

Connectors and Tap-off units

Switching with an Electrical handle

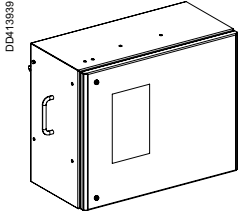

KSB160 and 250 DB 4

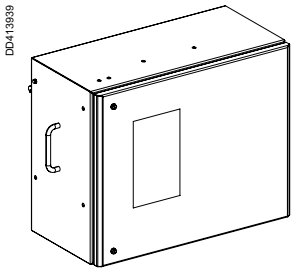

KSB400 DB 4

**Delivered equipped with a mounting plate for 1 Circuit Breaker
For NSX Circuit breaker with Electrical handle**

Cat. n°	KSB160DB412	KSB250DB412	KSB400DB412
Compatible with	KSA100 to 1000	KSA100 to 1000	KSA500 to 1000

Rating (A)	160	250	400
Polarity	3L + N + PE	3L + N + PE	3L + N + PE
Phase Diagram			

Cabling			
Protection Type (Not Supplied)	NSX160 - N, H, L	NSX250 - N, H, L	NSX400 - N, H, L

Body Material	Metal	Metal	Metal
Cable Output	1 rear 1.5 mm steel cable plate 245 x 130	-	1 rear 1.5 mm steel cable plate 345 x 130
Available Area (mm)	215 x 100	-	315 x 100

Connection	NSX Terminals	NSX Terminals	NSX Terminals
------------	---------------	---------------	---------------

Maximum Rigid Cable Size (mm ²)	See NSX catalog	See NSX catalog	See NSX catalog
Maximum Flexible Cable Size (mm ²)	See NSX catalog	See NSX catalog	See NSX catalog

Electrical handle	LV4294**	LV4294**	LV4315**
-------------------	----------	----------	----------

Additional Characteristics			
IP	IP55	IP55	IP55
Color	White	White	White
Weight (kg)	11	16	13,3
Selling Unit	1	1	1
MOQ	1	1	1

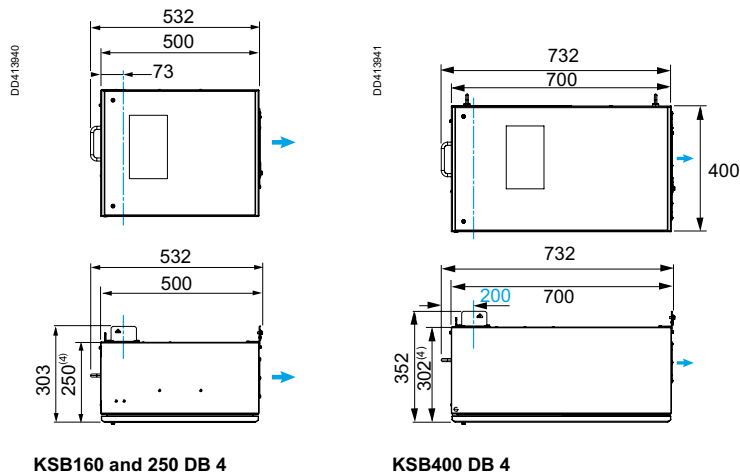

Advanced offer

Connectors and Tap-off units

Switching with an Electrical handle

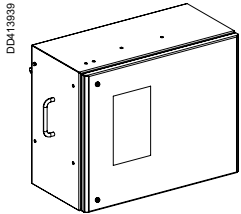

KSB160 and 250 DB 5

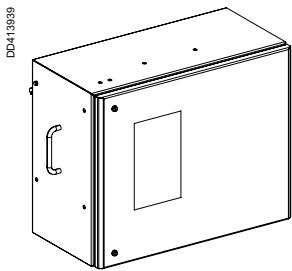

KSB400 DB 5

**Delivered equipped with a mounting plate for 1 Circuit Breaker
For NSX Circuit breaker with Electrical handle**

Cat. n°	KSB160DB512	KSB250DB512	KSB400DB512
Compatible with	KSA100 to 1000	KSA100 to 1000	KSA500 to 1000

Rating (A)	160	250	400
Polarity	3L + PEN	3L + PEN	3L + PEN
Phase Diagram			

Cabling			
Protection Type (Not Supplied)	NSX160 - N, H, L	NSX250 - N, H, L	NSX400 - N, H, L

Body Material	Metal	Metal	Metal
Cable Output	1 rear 1.5 mm steel cable plate 245 x 130	-	1 rear 1.5 mm steel cable plate 345 x 130
Available Area (mm)	215 x 100	-	315 x 100

Connection	NSX Terminals	NSX Terminals	NSX Terminals
------------	---------------	---------------	---------------

Maximum Rigid Cable Size (mm ²)	See NSX catalog	See NSX catalog	See NSX catalog
Maximum Flexible Cable Size (mm ²)	See NSX catalog	See NSX catalog	See NSX catalog

Electrical handle	LV4294**	LV4294**	LV4315**
-------------------	----------	----------	----------

Additional Characteristics			
IP	IP55	IP55	IP55
Color	White	White	White
Weight (kg)	11	16	22
Selling Unit	1	1	1
MOQ	1	1	1

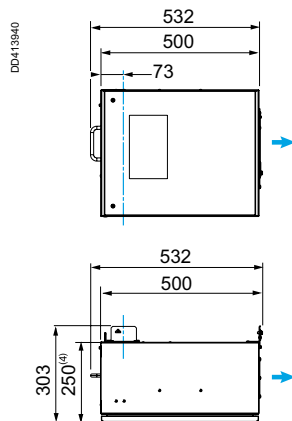

KSB160 and 250 DB 5

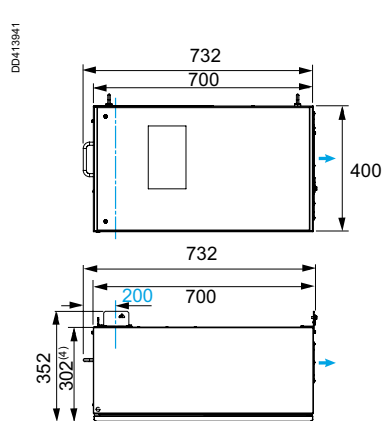

KSB400 DB 5



Advanced offer

Connectors and Tap-off units

Tap-off units Equipped with a Surge Arrester

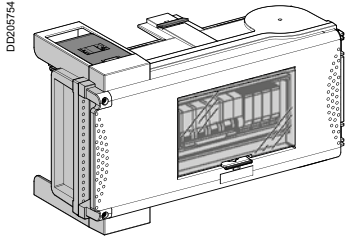

KSBQPRD

Delivered equipped with a Surge arrester
For line protection against Surge

Cat. n° KSBQPRD
 Compatible with KSA100 to 1000

Rating (A) 0

Polarity 3L + N + PE

Phase Diagram

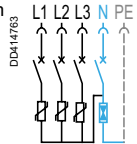

Cabling

Protection Type Quick PRD40r
 (Not Supplied)

Body Material Plastic
 Cable Output No need

Available No need
 Area (mm)

Connection No need

Maximum Rigid No need
 Cable Size (mm²)
 Maximum Flexible No need
 Cable Size (mm²)

Surge arrester
 3P + N, cat. no.
 16294

Additional Characteristics

IP IP55
 Color White
 Weight (kg) 3,4
 Selling Unit 1
 MOQ 1

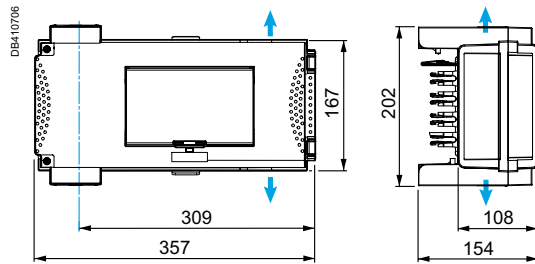

KSBQPRD

Advanced offer

Connectors and Tap-off units (Accessories)

Accessories for tap-off units

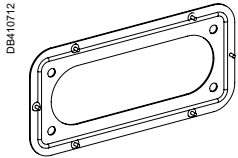

KSB160SFZFL21

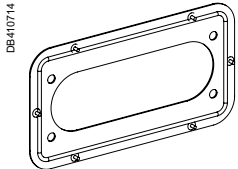

KSB250DCZFL21

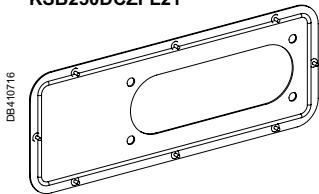

KSB400DCZFL21

Plate for FL21 flexible cable gland
Plate for tap-off units, compatible with FL21 flexible cable gland

Cat. n°	KSB160SFZFL21	KSB250DCZFL21	KSB400DCZFL21
Compatible with	KSB160 SF	KSB250 DC	KSB400 DC
Rating (A)	160	250	400
Polarity	-	-	-

Additional Characteristics

IP	-	-	-
Color	White	White	White
Weight (kg)	0,4	0,35	0,422
Selling Unit	1	1	1
MOQ	1	1	1

FL21 cable gland can be found on schneider-electric.com

Accessories for tap-off units

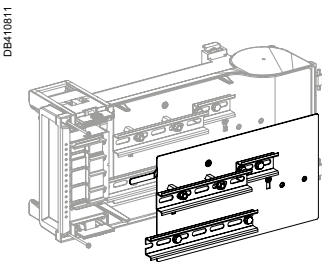

KSB63PMP

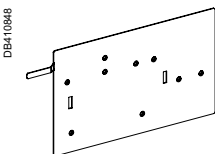

KSB63EGP

Accessories
Accessories for metering devices

Cat. n°	KSB63PMP	KSB63EGP
Compatible with	KSB100SV•	KSB63SM•8
Rating (A)	0	0
Polarity	-	-

Additional Characteristics

IP	IP55	IP55
Color	White	White
Weight (kg)	1,06	0,4
Selling Unit	1	1
MOQ	12	5

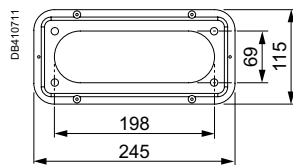

KSB160SFZFL21

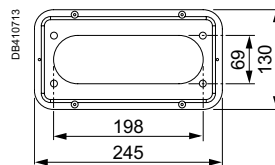

KSB250DCZFL21

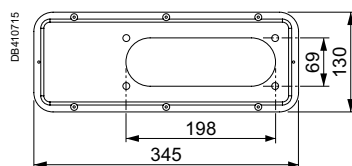

KSB400DCZFL21

E

Advanced offer

Accessories

For current KS offer

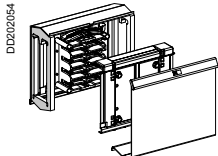

KSA250FA4

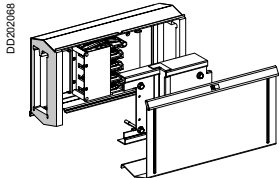

KSA400FA4

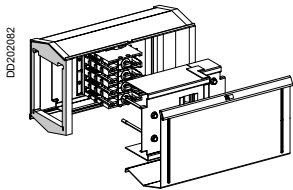

KSA500FA4

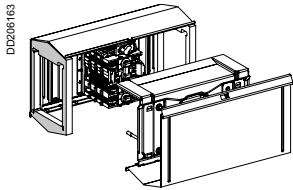

KSA800FA4

Jointing units

Adapters - Jointing units - From former KS to current KS

Cat. n°	KSA250FA4	KSA400FA4	KSA500FA4	KSA800FA4
Compatible with	KSA100 to 250	KSA100 to 400	KSA500	KSA500 to 800
Rating (A)	250	400	500	800
Polarity	3L + N + PE	3L + N + PE	3L + N + PE	3L + N + PE

Characteristics

	To connect former KS100/250 to KS100/250	To connect former KS400 to KS400	To connect former KS500 to KS500	To connect former KS800 to KS630/800

Additional Characteristics

	KSA250FA4	KSA400FA4	KSA500FA4	KSA800FA4
IP	IP55	IP55	IP55	IP55
Color	White	White	White	White
Weight (kg)	2,7	4,5	3,65	7,3
Selling Unit	1	1	1	1
MOQ	1	1	1	1

See description next pages

For current KS offer

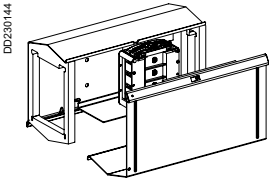

KSA500FR425

Jointing units

Adapter - Jointing unit - From KS 400 to KS 500/1000A

Cat. n°	KSA500FR425
Compatible with	KSA500 to 1000
Rating (A)	1000
Polarity	3L + N + PE

Characteristics

To connect KS400 to KS500/1000

Additional Characteristics

IP	IP55
Color	White
Weight (kg)	5
Selling Unit	1
MOQ	1

See description next pages

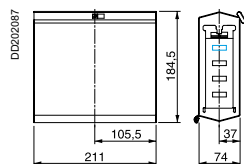

KSA250FA4

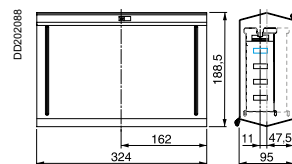

KSA400FA4

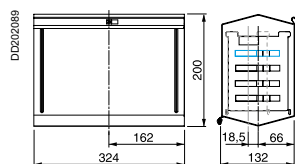

KSA500FA4

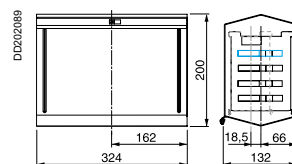

KSA800FA4

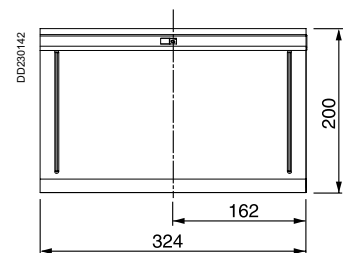

KSA500FR425

Advanced offer

Accessories

For former KS offer

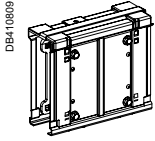

KSB25YA4

End covers and Jointing units

Former End covers and Former Jointing unit for KS 100 to 250A

Cat. n°	KSB25YA4
Compatible with	KSA100 to 250
Rating (A)	250
Polarity	-

Characteristics

Jointing unit for former KS250

Additional Characteristics

IP	IP55
Color	White
Weight (kg)	1,19
Selling Unit	1
MOQ	1
	See description next pages

For former KS offer

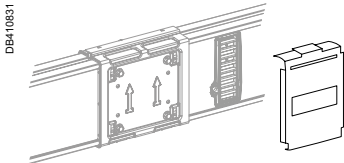

KSE80YB2

Blanking plate and Sprinkler Kit

Former IP54 blanking plate for outlets and Sprinkler proofing accessory

Cat. n°	KSE80YB2	KSE50YA2
Compatible with	KSA500 to 1000	KSA500
Rating (A)	0	0
Polarity	-	-

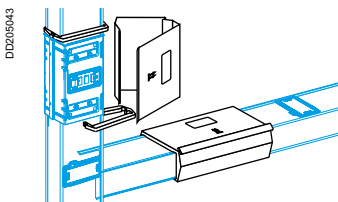

KSE50YA2

Additional Characteristics

IP	IP55	IP55
Color	White	White
Weight (kg)	0,145	2,1
Selling Unit	1	1
MOQ	10	1

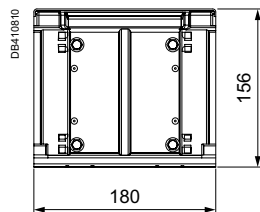

KSB25YA4

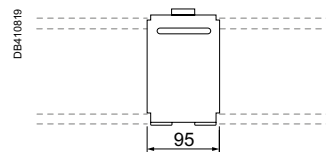

KSE80YB2

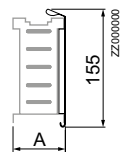

Description Accessories

From 100 to 1000 A

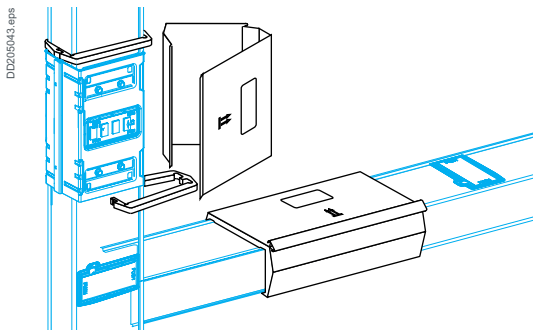

Selection guide of adapters and jointing units

Cat. no.	Line (A)			
	Beginning	End	Power	
KSA250ZJ4	100	160	100	
		250	100	
	160	100	100	
		250	160	
	250	100	100	
		160	160	
KSA1000ZJ4	1000	800	800	
	800	1000	800	
KSA630ZJ4 or KSA1000ZJ4	500	630	500	
		800	500	
		1000	500	
	630	500	500	
		800	630	
		1000	630	
	800	500	500	
		630	630	
		1000	500	
	KSA500FR425	400	500	400
			630	630
			800	800
1000			1000	
500		400	400	
630		400	400	
800	400	400		
1000	400	400		

Lead-sealing system

This prohibits access to live parts. Two systems are available: one is installed either on the power supply box or on the busbar connector, and the other on the tap-off points.

Spare parts

Sprinkler kit

To comply with the sprinkler tests (guaranteeing operation under vertically and horizontally sprayed water for 50 minutes), each electrical jointing system should be fitted with a reinforced protection kit (the jointing sleeve).

Separate parts

Electrical and mechanical connecting plates
These are blocks fitted with elastic contacts in silver-plated copper. They automatically provide electrical connection of all conductors.

IP55 plugs

These plugs protect the busbar trunking tap-off points.

Adapters

These parts allow Canalis KS busbar trunking to be connected to previous KS generation busbar trunking.

Reducer element

These part allow connection of KS busbar trunking of different sizes and ratings (Size 1 = from 100 to 400 A; Size 3 = from 500 to 1000 A).

Protection end-pieces

The protection end-pieces insulate and protect the connectors at the end of busbar trunking. They are installed on the last busbar trunking of the distribution line.

Canalis KS range

Rising main offer

A dedicated range for vertical runs

Description.....	page 171
Overview	page 174
Commercial numbers and dimensions.....	page 180

Description

Rising mains

Medium-power busbar trunking for multi-storey buildings

General

Canalis KS risers distribute power to each floor in multi-level buildings (office buildings, hotels, hospitals, car parks and ships).

In this application, Canalis KS offers its many advantages:

- aluminium conductors, equipped with bimetal aluminium/silver-plated copper contacts at junctions and tap-off points
- a mechanical and electrical jointing system that provides automatic and simultaneous jointing of all live conductors and the continuity of the protective earth conductor, as well as its connection with the casing. This jointing block also absorbs the difference in conductor and casing thermal expansion for each length
- tap-off outlets with automatic shutters.

When installed vertically, the Canalis KS degree of protection is IP55.

How to build rising mains

A. Use an end feed unit, type **KSA...ABD4** in order to have the neutral on the right-hand side in the riser.

B. Two solutions are available to support the riser.

B1. Use the **KSB...ZV1** bottom support for risers. Placed at the bottom of the riser and attached to the wall, this support takes the entire weight of the rising mains. Consequently, depending on the rating, the maximum height of the rising mains is limited as indicated below.

Rating (A)	Max. recommended height	Max. recommended weight by support
100 and 250	40 m	680 kg
400	30 m	680 kg
500	70 m	1760 kg
630	50 m	1760 kg
800	50 m	1760 kg
1000	40 m	1760 kg

B2. Use floor supports **KSB...ZV3**, only compatible with made to measure elements **KSA...CM4AF**. They are used to support the riser on each floor of the building, for enhanced flexibility in carrying out the various installation phases. With this support, riser sections can be installed even when the lower floors have not been completed.

Rating (A)	Max. recommended height	Max. recommended weight by support
All	150 m	440 kg

Above 100 m, avoid the use of fixed components at the bottom or the top (e.g. elbows) and supply power using cables wherever possible.

C. Use custom-length fire barriers to block fire propagation between floors. They also provide the means to adjust to the distance between floors.

D. Use standard straight lengths, 2 or 2.50 metres long. Lengths and fire barriers can be combined to provide:

Solution 1: for a distance of 2800 mm to 4300 mm between floors, three tap-off outlets with **KSA...EV4203** straight lengths,

Solution 2: for a distance of 3400 mm to 4800 mm between floors, four tap-off outlets with **KSA...EV4254** straight lengths,

E. Use **KSB 1000ZV2** fixings to guide the riser on each floor.

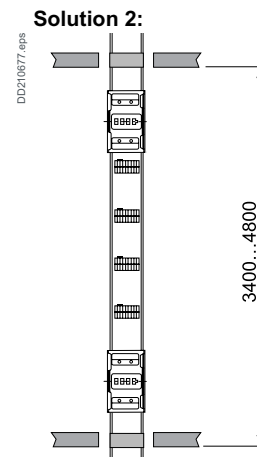
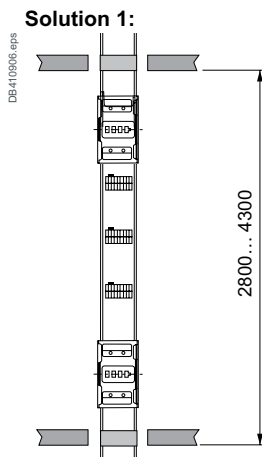
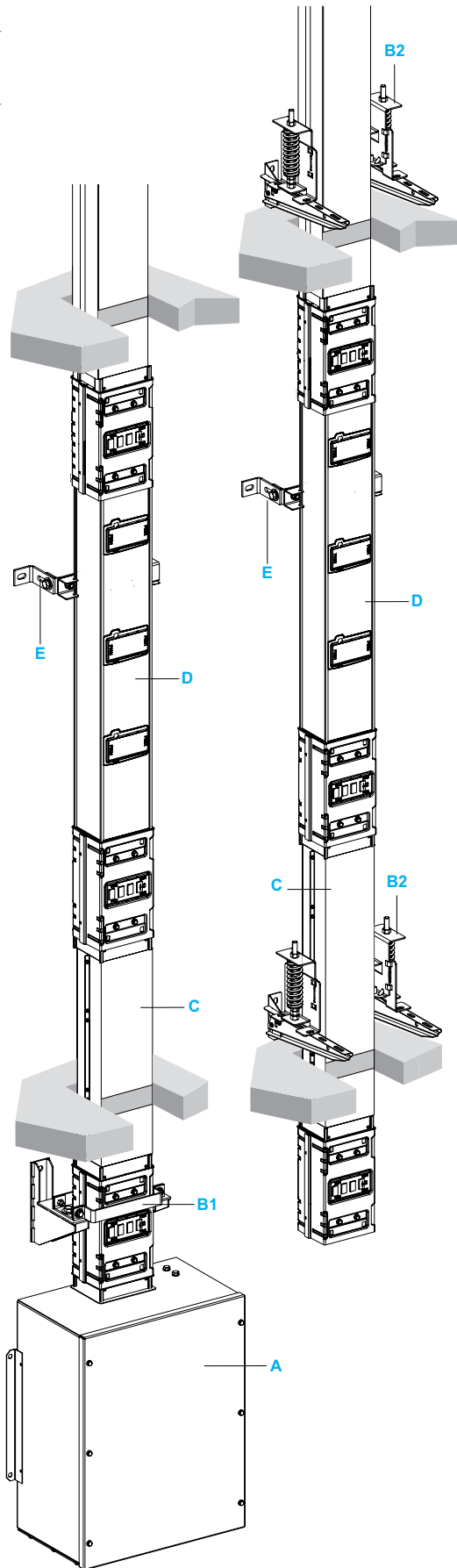

Description

Rising mains

Medium-power busbar trunking for multi-storey buildings

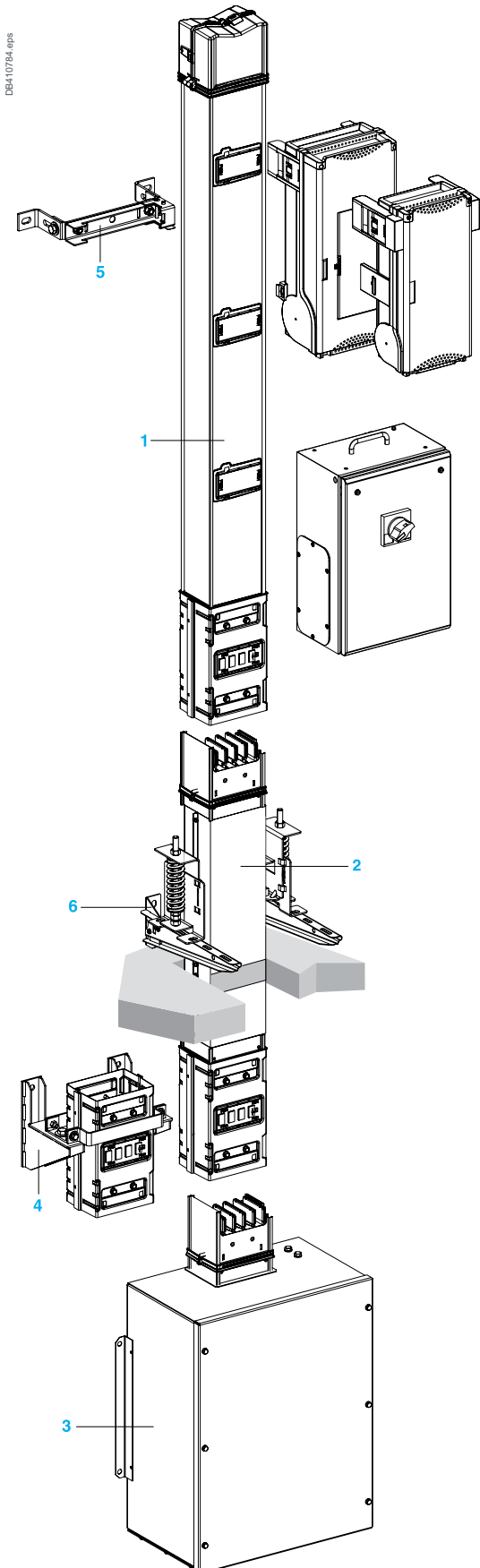

Riser components

1. Straight lengths for distribution

Specially designed for rising mains, they are available in 3 lengths (1.5, 2 and 2.5 metres).

They have three or four tap-off outlets, all on the same side. The outlets are positioned to enable connection of up to three 160 A tap-off units for Compact NSX circuit breakers on the two-metre lengths and up to four on the 2.5-metre lengths.

2. Custom-length fire-barrier lengths

Installed at each floor level, these lengths avoids any risk of fire propagation from one floor to another via the trunking. These fire barriers have been tested in a certified laboratory and comply with standard EN 1363-1. The laboratory report lists the following results:

- thermal insulation: ≥ 120 minutes
- resistance to flames: ≥ 120 minutes
- stability: ≥ 120 minutes.

Provided in custom lengths, these barriers are used with the straight lengths to adjust to the exact height of each floor.

Feed units

Direct supply from a switchboard

The trunking connects directly to a switchboard via a spreader. In this configuration, the riser is supplied through a horizontal section made of lengths without tap-off outlets.

3. Supply via cables

Equipped with terminals made of tinned aluminium, this feed unit is designed for connection to copper or aluminium cables equipped with the necessary lugs. The feed unit is also equipped with an aluminium gland plate. The plate can be removed and is not pre-drilled.

Fixing systems

4. Bottom support

This component attaches to the first jointing unit at the base of the riser and is attached to the wall by two brackets. It supports the entire riser (see height limitations on the previous page).

Note: the foot of the riser is a special jointing unit to which a wall bracket is installed.

5. Guides

These guides, clipped to the riser, maintain it in the vertical position on each floor. They not block access to the tap-off outlets (ratings 500 to 1000 A).

6. Floor supports

Fixed to the floor or wall (via Canalis 200 mm cantilever arms), they attach to the sides of a special component (with or without fire barrier).

Tap-off units

Dedicated or standard KS tap-off units can be used (see compatibility page).

Accessories

Sprinkler kit

To comply with the sprinkler tests (guaranteeing operation under vertically and horizontally sprayed water for 50 minutes), each electrical jointing system should be fitted with a reinforced protection kit (the jointing sleeve).

Description

Compatibility of tap-off units and busbar trunkings

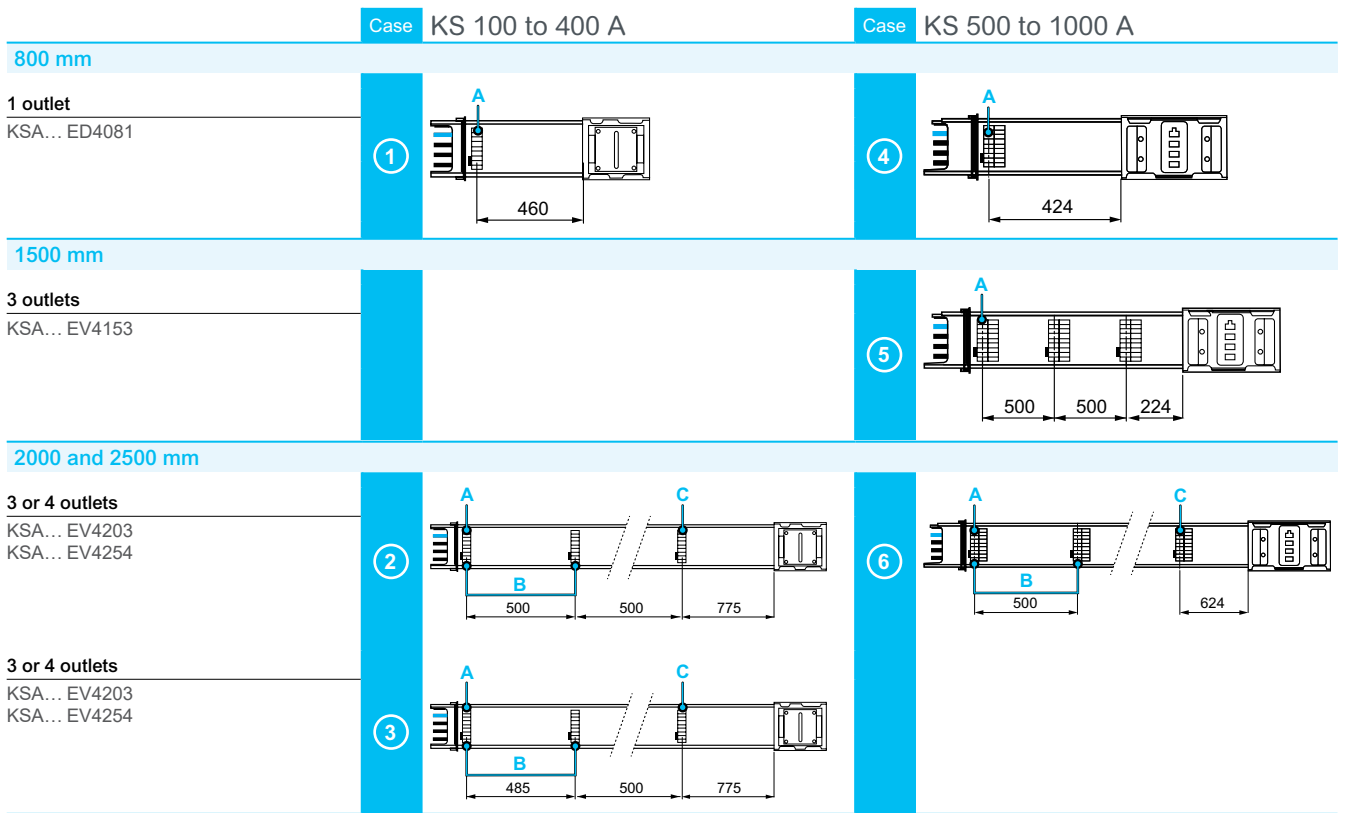

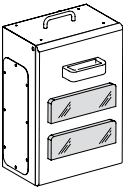
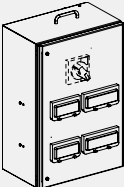
	Case KS 100 to 400 A - Mountings available on:			Case KS 500 to 1000 A - Mountings available on:		
	A 1st outlet	B 2 consecutive outlets	C Last outlet	A 1st outlet	B 2 consecutive outlets	C Last outlet
 KSB160SM*** W* = 450 mm	1	•		4	-	
	2	-	■	5	•	■
	3	•	■	•	6	•
 KSB250SM428 ⁽¹⁾ KSB250DC4SP ⁽²⁾ ⁽¹⁾ W = 600 mm ⁽²⁾ W = 500 mm	1	-		4	-	
	2	-	△	5	•	△
	3	•	△	•	6	•

* W = width of the tap-off unit

- The tap-off unit can be mounted at this position
- The right outlet is available for another tap-off unit
- △ The right outlet is hidden by the tap-off unit
- X Impossible to mount this tap-off unit at this position

F

Offer overview

Busbar ratings (A)

	100	160	250	400	500	630	800	1000
Feed units								
Mounted on the busway								
Without line protection								
Right mounting 3L+N+PE	KSA100AB4	KSA250AB4	KSA250AB4	KSA400AB4	KSA630ABD4	KSA630ABD4	KSA1000ABD4	KSA1000ABD4
For line protection with a NSX (not included)								
Right mounting 3L+N+PE	KSA250ABDD4	KSA250ABDD4	KSA250ABDD4	KSA400ABDD4	KSA630ABDD4	KSA630ABDD4	KSA1000ABDD4	KSA1000ABDD4
3L+PEN	KSA250ABDD5	KSA250ABDD5	KSA250ABDD5	KSA400ABDD5	KSA630ABDD5	KSA630ABDD5	KSA1000ABDD5	KSA1000ABDD5
Mounted on the panelboard								
Without line protection								
Flange units 3L+N+PE	KSA250AE4	KSA250AE4	KSA250AE4	KSA400AE4	KSA630AE4	KSA630AE4	KSA1000AE4	KSA1000AE4

Straight lengths

Vertical mounting									
For distribution - 3L+N+PE									
At the foot of a riser									
800 mm	1 outlet	KSA100ED4081	KSA250ED4081	KSA250ED4081	KSA400ED4081	KSA630ED4081	KSA630ED4081	KSA1000ED4081	KSA1000ED4081
With standard density outlets on 1 side only									
1500 mm	3 outlets	-	-	-	-	KSA500EV4153	KSA630EV4153	KSA800EV4153	KSA1000EV4153
2000 mm	3 outlets	KSA100EV4203	KSA250EV4203	KSA250EV4203	KSA400EV4203	KSA500EV4203	KSA630EV4203	KSA800EV4203	KSA1000EV4203
2500 mm	4 outlets	KSA100EV4254	KSA250EV4254	KSA250EV4254	KSA400EV4254	KSA500EV4254	KSA630EV4254	KSA800EV4254	KSA1000EV4254
For transport (without outlets) - 3L+N+PE									
Made-to-measure									
500 to 1900 A		KSA250CM4A	KSA250CM4A	KSA250CM4A	KSA400CM4A	KSA630CM4A	KSA630CM4A	KSA1000CM4A	KSA1000CM4A
Made-to-measure - With 1 fire barrier free positioning									
800 to 1900 A		KSA250CM4AF	KSA250CM4AF	KSA250CM4AF	KSA400CM4AF	KSA630CM4AF	KSA630CM4AF	KSA1000CM4AF	KSA1000CM4AF

Fixing brackets and supports

Fixing bracket and supports for vertical installation									
To support all the run									
Installed at the bottom of the riser		KSB250ZV1	KSB250ZV1	KSB250ZV1	KSB400ZV1	KSB630ZV1	KSB630ZV1	KSB1000ZV1	KSB1000ZV1
To support the run at each floor									
Spring hanger		KSB1000ZV3	KSB1000ZV3	KSB1000ZV3	KSB1000ZV3	KSB1000ZV3	KSB1000ZV3	KSB1000ZV3	KSB1000ZV3
To guide the run at each floor									
Fixing surrounding the busway		KSB1000ZV2	KSB1000ZV2	KSB1000ZV2	KSB1000ZV2	KSB1000ZV2	KSB1000ZV2	KSB1000ZV2	KSB1000ZV2

Connectors & Tap-off units dedicated to vertical installation ^{(1) (2)}

Disconnection by opening the door		
Delivered equipped with 2 DIN Rails		
For 18 mm modular devices - 160 A - 3L+N+PE	KSB160SM424	KSB160SM424
For 18 mm modular devices - 160 A - 3L+PEN	KSB160SM524	KSB160SM524
Switching with a rotary handle located on the door		
Delivered equipped with a mounting plate for 1 circuit breaker - 250 A - 3L+N+PE		
For NSX circuit breaker + equipped with 2 DIN rails - Tap-off unit mountable over the junction unit	KSB250SM428	KSB250SM428
For NSX circuit breaker - Tap-off unit mountable over the junction unit	KSB250DC4SP	KSB250DC4SP

(1) Others tap-off units from Classic and Advanced offers can be fitted to a vertical run.

(2) See compatibility page for mounting limitations.

"KS*****": Reference specifically adapted to the rating of the busbar trunking

"KS*****": Compatible reference with the rating of the busbar trunking

Rising main offer

Feed units

Right mounting

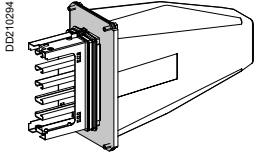

KSA100AB4

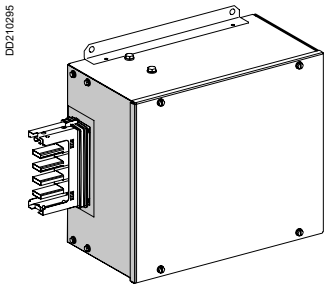

KSA250 and 400 AB4

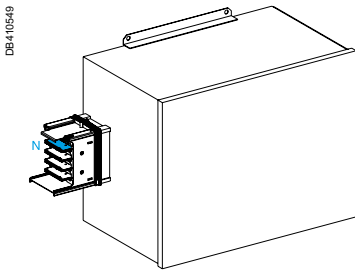

KSA630 and 1000 ABD

Mounted on the busway Without line protection

Cat. n°	KSA100AB4	KSA250AB4	KSA400AB4	KSA630ABD4	KSA1000ABD4
Compatible with	KSA100 to 250	KSA100 to 250	KSA400	KSA500 to 1000	KSA500 to 1000

A in the line (mm)	390	501	501	753	753
--------------------	-----	-----	-----	-----	-----

Rating (A)	100	250	400	630	1000
Polarity	3L + N + PE	3L + N + PE	3L + N + PE	3L + N + PE	3L + N + PE
Phase Diagram					

Cabling					
Protection Type (Not Supplied)	None	None	None	None	None

Input Type	Cable Gland PG29	Alu. plate 300 x 170 x 3	Alu. plate 340 x 208 x 3	Alu. plate 446 x 276 x 3	Alu. plate 446 x 358 x 3
Available Area (mm)	Ø37.5 mm	240x130	280 x 160	386 x 240	386 x 320
Maximum Cable size (mm ²)	Cable max Ø23mm	4 x 240	4 x 300 or 8 x 120	4 x 300 or 8 x 240	12 x 300
Connection	Mechanical lugs (Zinc plated steel)	With Compression Lugs ⁽¹⁾ onto tin-plated aluminum bars	With Compression Lugs ⁽¹⁾ onto tin-plated aluminum bars	With Compression Lugs ⁽¹⁾ onto tin-plated aluminum bars	With Compression Lugs ⁽¹⁾ onto tin-plated aluminum bars
Capability Per Phase	5 x 16 mm ²	1 x Ø13 mm (L) + 1 x Ø8 mm (PE)	1 x Ø13 mm (L) + 2 x Ø11 mm (PE)	3 x Ø14 mm (L) + 3 x Ø11 mm (PE)	4 x Ø15 mm (L) + 4 x Ø10 mm (PE)

- (1) Not included (1) Not included (1) Not included (1) Not included

Additional Characteristics

IP	IP55	IP55	IP55	IP55	IP55
Color	White	White	White	White	White
Weight (kg)	1,8	8	11,2	22	25
Selling Unit	1	1	1	1	1
MOQ	1	1	1	1	1

Supplied with an End cover

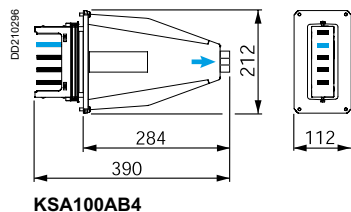

KSA100AB4

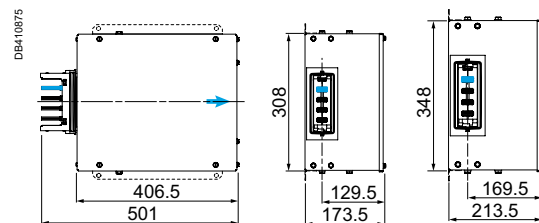

KSA250 and 400 AB4

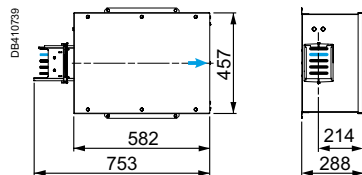

KSA630ABD4

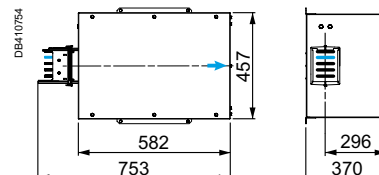

KSA1000ABD4

Rising main offer

Feed units

Right mounting

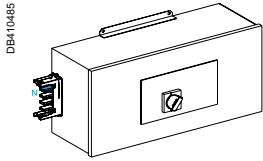

KSA250 and 400 ABDD

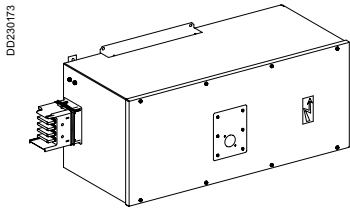

KSA630 and 1000 ABDD

Mounted on the busway For line protection with a NSX (not delivered)

Cat. n°	KSA250ABDD4	KSA400ABDD4	KSA630ABDD4	KSA1000ABDD4
Compatible with	KSA100 to 250	KSA400	KSA500 to 1000	KSA500 to 1000
A in the line (mm)	742	860	1258	1267
Rating (A)	250	400	630	1000
Polarity	3L + N + PE	3L + N + PE	3L + N + PE	3L + N + PE
Phase Diagram				
Cabling				
Protection Type (Not Supplied)	NSX250 N, H, L	NSX400 N, H, L	NSX630 N, H, L	NS1000
Input Type	Alu. plate 300 x 267 x 3	Alu. plate 340 x 267 x 3	Alu. plate 446 x 378 x 3	Alu. plate 446 x 458 x 3
Available Area (mm)	240 x 220	280 x 220	386 x 330	386 x 410
Maximum Cable size (mm ²)	4 x 240	4 x 300 or 8 x 120	4 x 300 or 8 x 240	12 x 300
Connection	On NSX terminals	On NSX terminals	On NSX terminals	On NS terminals
Capability Per Phase	See Compact NSX catalog	See Compact NSX catalog	See Compact NSX catalog	See Compact NS1000 catalog
	NSX250: Extended rotary handle LV429338	NSX400: Extended rotary handle LV432598	NSX630: Extended rotary handle LV432598	NS 1000: Extended rotary handle 33878

Additional Characteristics

IP	IP55	IP55	IP55	IP55
Color	White	White	White	White
Weight (kg)	17,1	22,2	39,2	52
Selling Unit	1	1	1	1
MOQ	1	1	1	1

Supplied with an End cover

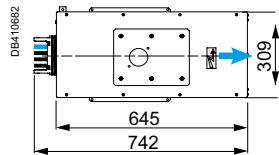

KSA250ABDD4

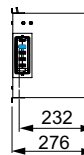

KSA400ABDD4

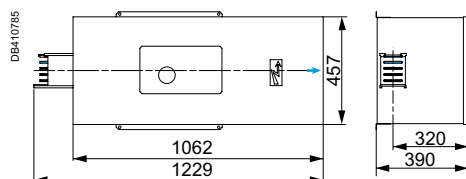

KSA630ABDD4

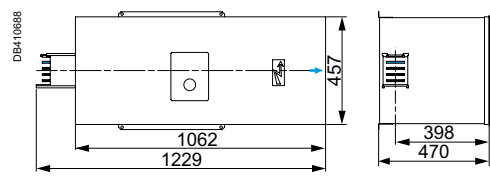

KSA1000ABDD4

Rising main offer

Feed units

Right mounting

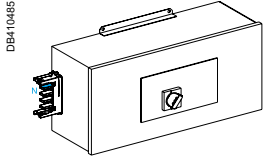

KSA250 and 400 ABDD

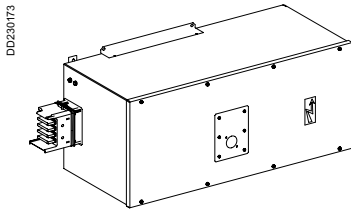

KSA630 and 1000 ABDD

Mounted on the busway
For line protection with a NSX (not delivered)

Cat. n°	KSA250ABDD5	KSA400ABDD5	KSA630ABDD5	KSA1000ABDD5
Compatible with	KSA100 to 250	KSA400	KSA500 to 1000	KSA500 to 1000
A in the line (mm)	742	860	1258	1267
Rating (A)	250	400	630	1000
Polarity	3L + PEN	3L + PEN	3L + PEN	3L + PEN
Phase Diagram				
Cabling				
Protection Type (Not Supplied)	NSX250 N, H, L	NSX400 N, H, L	NSX630 N, H, L	NS1000
Input Type	Alu. plate 300 x 267 x 3	Alu. plate 340 x 267 x 3	Alu. plate 446 x 378 x 3	Alu. plate 446 x 458 x 3
Available Area (mm)	240 x 220	280 x 220	386 x 330	386 x 410
Maximum Cable size (mm ²)	4 x 240	4 x 300 or 8 x 120	4 x 300 or 8 x 240	12 x 300
Connection	On NSX terminals	On NSX terminals	On NSX terminals	On NS terminals
Capability Per Phase	See Compact NSX catalog	See Compact NSX catalog	See Compact NSX catalog	See Compact NS1000 catalog
	NSX250: Extended rotary handle LV429338	NSX400: Extended rotary handle LV432598	NSX630: Extended rotary handle LV432598	NS 1000: Extended rotary handle 33878

Additional Characteristics

IP	IP55	IP55	IP55	IP55
Color	White	White	White	White
Weight (kg)	17,3	22,6	39,9	53,5
Selling Unit	1	1	1	1
MOQ	1	1	1	1

Supplied with an End cover

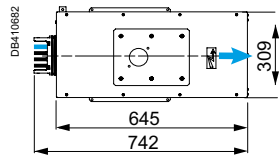

KSA250ABDD5

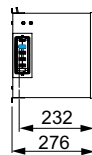

KSA400ABDD5

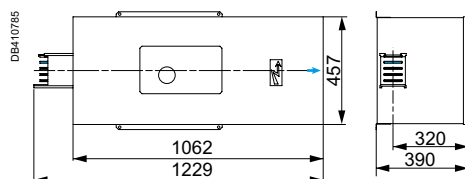
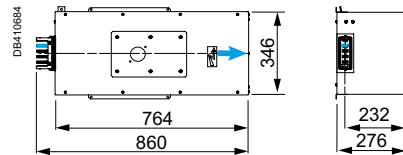

KSA630ABDD5

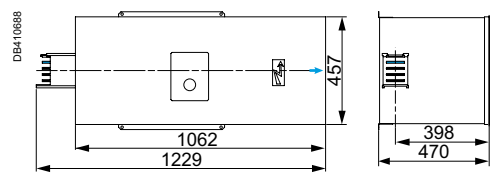

KSA1000ABDD5

Rising main offer

Feed units

Flange units

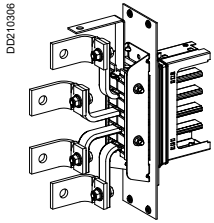

KSA250 and 400 AE

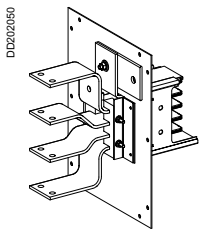

KSA630 and 1000 AE

Mounted on the switchboard Without line protection

Cat. n°	KSA250AE4	KSA400AE4	KSA630AE4	KSA1000AE4
Compatible with	KSA100 to 250	KSA400	KSA500 to 1000	KSA500 to 1000
A in the line (mm)	100	100	172	172
Rating (A)	250	400	630	1000
Polarity	3L + N + PE	3L + N + PE	3L + N + PE	3L + N + PE
Phase Diagram				
Cabling				
Protection Type (Not Supplied)	None	None	None	None
Input Type	-	-	-	-
Available Area (mm)	-	-	-	-
Maximum Cable size (mm ²)	-	-	-	-
Connection	With Compression Lugs ⁽¹⁾ onto tin-plated aluminum bars	With Compression Lugs ⁽¹⁾ onto tin-plated aluminum bars	With Compression Lugs ⁽¹⁾ onto tin-plated aluminum bars	With Compression Lugs ⁽¹⁾ onto tin-plated aluminum bars
Capability Per Phase	1 x Ø13 mm (L) + 1 x Ø9 mm (PE)	1 x Ø13 mm (L) + 1 x Ø9 mm (PE)	2 x Ø11 mm (L) + 1 x Ø14 mm (PE)	4 x Ø11 mm (L) + 1 x Ø14 mm (PE)
	(2) Not included	(2) Not included	⁽¹⁾ Not included	⁽¹⁾ Not included

Additional Characteristics

IP	-	-	-	-
Color	White	White	White	White
Weight (kg)	2	2,1	10,6	12
Selling Unit	1	1	1	1
MOQ	1	1	1	1

Supplied with an End cover

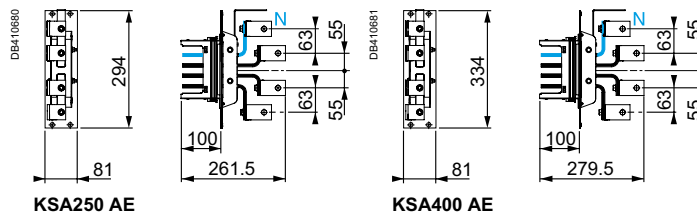

KSA250 AE

KSA400 AE

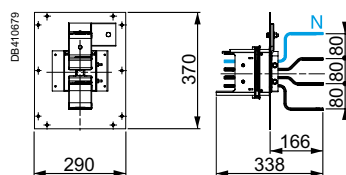

KSA630 and 1000 AE

Rising main offer

Straight lengths

At the foot of a riser - 0.8 m

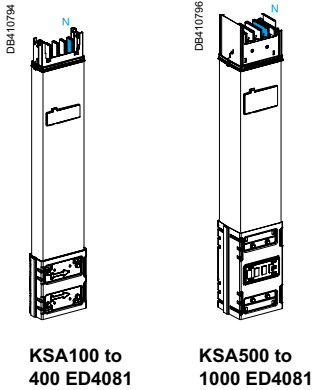

For Distribution
Vertical mounting

Cat. n°	KSA100ED4081	KSA250ED4081	KSA400ED4081	KSA630ED4081	KSA1000ED4081
Compatible with	KSA100 to 250	KSA100 to 250	KSA400	KSA500 to 1000	KSA500 to 1000
A in the line (mm)	800	800	800	800	800
Rating (A)	100	250	400	630	1000
Polarity	3L + N + PE	3L + N + PE	3L + N + PE	3L + N + PE	3L + N + PE

Characteristics

Number	1	1	1	1	1
Of Outlet(s)					
Outlet(s) Position	On the front side	On the front side	On the front side	On the front side	On the front side
Distance Between -					
Outlets (mm)					
Fire Barrier	No	No	No	No	No

Additional Characteristics

IP	IP55	IP55	IP55	IP55	IP55
Color	White	White	White	White	White
Weight (kg)	6,5	6,5	7,8	16,5	16,8
Selling Unit	1	1	1	1	1
MOQ	1	1	1	1	1

With Standard density outlets on 1 side only - 1.5 m

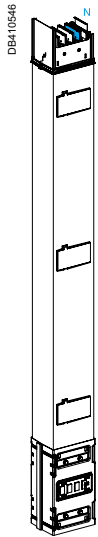

For Distribution
Vertical mounting

Cat. n°	KSA500EV4153	KSA630EV4153	KSA800EV4153	KSA1000EV4153
Compatible with	KSA500 to 1000	KSA500 to 1000	KSA500 to 1000	KSA500 to 1000
A in the line (mm)	1500	1500	1500	1500
Rating (A)	500	630	800	1000
Polarity	3L + N + PE	3L + N + PE	3L + N + PE	3L + N + PE

Characteristics

Number	3	3	3	3
Of Outlet(s)				
Outlet(s) Position	On the front side	On the front side	On the front side	On the front side
Distance Between	500	500	500	500
Outlets (mm)				
Fire Barrier	No	No	No	No

Additional Characteristics

IP	IP55	IP55	IP55	IP55
Color	White	White	White	White
Weight (kg)	19,5	20,6	23,6	29,2
Selling Unit	1	1	1	1
MOQ	1	1	1	1

ED Elements can also be used in vertical position with potentially no access to the rear outlets

KSA500 to 1000 EV •15•

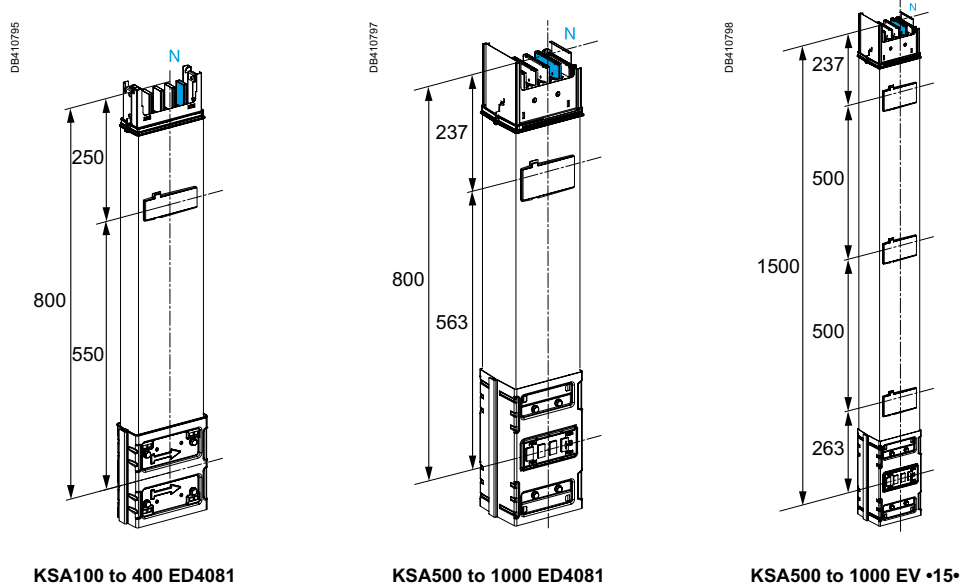

Rising main offer

Straight lengths

With Standard density outlets on 1 side only - 2 m

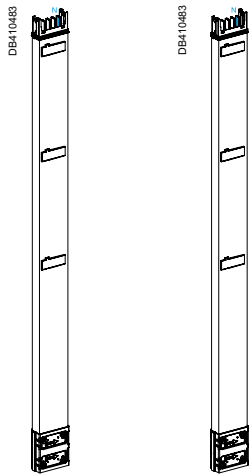

KSA100 to 250 EV •20•

KSA 400 EV •20•

For Distribution Vertical mounting

Cat. n°	KSA100EV4203	KSA250EV4203	KSA400EV4203
Compatible with	KSA100 to 250	KSA100 to 250	KSA400
A in the line (mm)	2000	2000	2000
Rating (A)	100	250	400
Polarity	3L + N + PE	3L + N + PE	3L + N + PE

Characteristics			
Number	3	3	3
Of Outlet(s)			
Outlet(s) Position	On the front side	On the front side	On the front side
Distance Between	500	500	1 st outlet at 485 and then 500
Outlets (mm)			
Fire Barrier	No	No	No

Additional Characteristics			
IP	IP55	IP55	IP55
Color	White	White	White
Weight (kg)	7	10	13,5
Selling Unit	1	1	1
MOQ	1	1	1

ED Elements can also be used in vertical position with potentially no access to the rear outlets

With Standard density outlets on 1 side only - 2 m

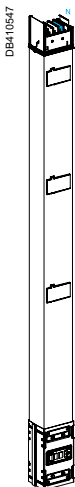

KSA500 to 1000 EV •20•

For Distribution Vertical mounting

Cat. n°	KSA500EV4203	KSA630EV4203	KSA800EV4203	KSA1000EV4203
Compatible with	KSA500 to 1000	KSA500 to 1000	KSA500 to 1000	KSA500 to 1000
A in the line (mm)	2000	2000	2000	2000
Rating (A)	500	630	800	1000
Polarity	3L + N + PE	3L + N + PE	3L + N + PE	3L + N + PE

Characteristics				
Number	3	3	3	3
Of Outlet(s)				
Outlet(s) Position	On the front side	On the front side	On the front side	On the front side
Distance Between	500	500	500	500
Outlets (mm)				
Fire Barrier	No	No	No	No

Additional Characteristics				
IP	IP55	IP55	IP55	IP55
Color	White	White	White	White
Weight (kg)	23	24,5	29	36,5
Selling Unit	1	1	1	1
MOQ	1	1	1	1

ED Elements can also be used in vertical position with potentially no access to the rear outlets

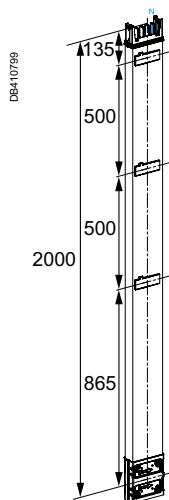

KSA100 to 250 EV •20•

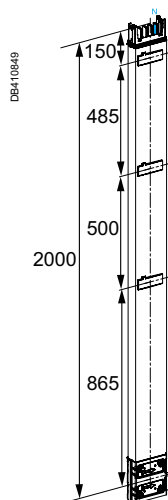

KSA 400 EV •20•

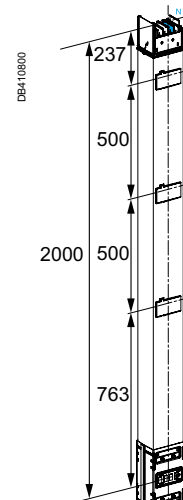

KSA500 to 1000 EV •20•

Rising main offer

Straight lengths

With Standard density outlets on 1 side only - 3 m

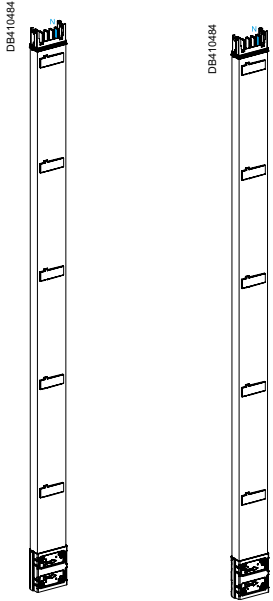

KSA100 to 250 EV •25•

KSA 400 EV •25•

For Distribution
Vertical mounting

Cat. n°	KSA100EV4254	KSA250EV4254	KSA400EV4254
Compatible with	KSA100 to 250	KSA100 to 250	KSA400
A in the line (mm)	2500	2500	2500
Rating (A)	100	250	400
Polarity	3L + N + PE	3L + N + PE	3L + N + PE

Characteristics

Number	4	4	4
Of Outlet(s)			
Outlet(s) Position	On the front side	On the front side	On the front side
Distance Between	500	500	1st outlet at 485 and then 500
Outlets (mm)			
Fire Barrier	No	No	No

Additional Characteristics

IP	IP55	IP55	IP55
Color	White	White	White
Weight (kg)	8,5	12	16,5
Selling Unit	1	1	1
MOQ	1	1	1

ED Elements can also be used in vertical position with potentially no access to the rear outlets

With Standard density outlets on 1 side only - 3 m

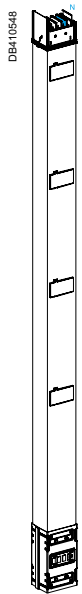

KSA500 to 1000 EV •25•

For Distribution
Vertical mounting

Cat. n°	KSA500EV4254	KSA630EV4254	KSA800EV4254	KSA1000EV4254
Compatible with	KSA500 to 1000	KSA500 to 1000	KSA500 to 1000	KSA500 to 1000
A in the line (mm)	2500	2500	2500	2500
Rating (A)	500	630	800	1000
Polarity	3L + N + PE	3L + N + PE	3L + N + PE	3L + N + PE

Characteristics

Number	4	4	4	4
Of Outlet(s)				
Outlet(s) Position	On the front side	On the front side	On the front side	On the front side
Distance Between	500	500	500	500
Outlets (mm)				
Fire Barrier	No	No	No	No

Additional Characteristics

IP	IP55	IP55	IP55	IP55
Color	White	White	White	White
Weight (kg)	28	30	35,5	44
Selling Unit	1	1	1	1
MOQ	1	1	1	1

ED Elements can also be used in vertical position with potentially no access to the rear outlets

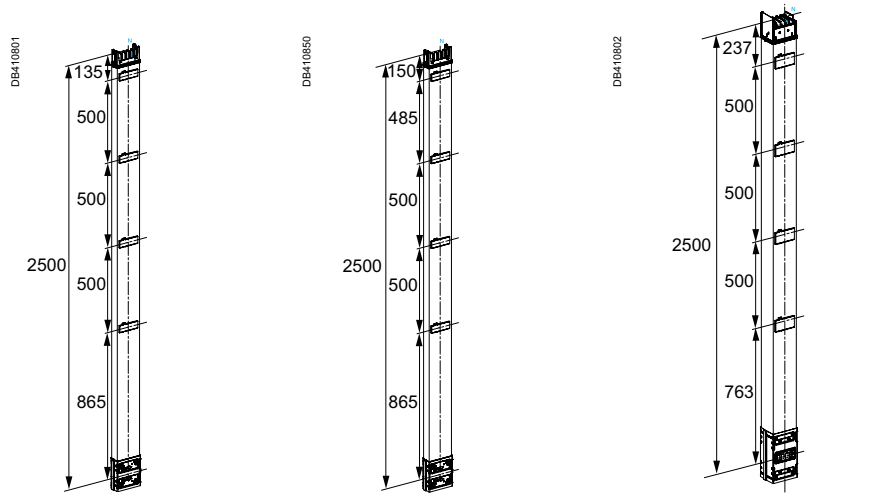

KSA100 to 250 EV •25•

KSA 400 EV •25•

KSA500 to 1000 EV •25•

Rising main offer

Straight lengths

Made-to-measure

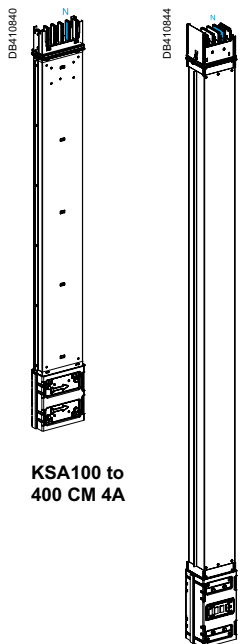

KSA100 to 400 CM 4A

KSA500 to 1000 CM 4A

For Transport (without Outlets) Vertical mounting

Cat. n°	KSA250CM4A	KSA400CM4A	KSA630CM4A	KSA1000CM4A
Compatible with	KSA100 to 250	KSA400	KSA500 to 1000	KSA500 to 1000
A in the line (mm)	500 to 1900	500 to 1900	500 to 1900	500 to 1900
Rating (A)	250	400	630	1000
Polarity	3L + N + PE	3L + N + PE	3L + N + PE	3L + N + PE

Characteristics				
Fire Barrier	No	No	No	No

Additional Characteristics				
IP	IP55	IP55	IP55	IP55
Color	White	White	White	White
Weight (kg)	8	10	30	32,2
Selling Unit	1	1	1	1
MOQ	1	1	1	1

Made-to-measure - With 1 fire barrier

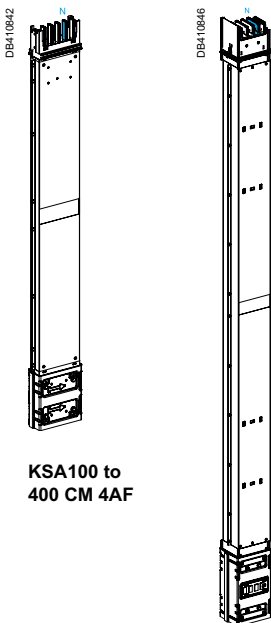

KSA100 to 400 CM 4AF

KSA500 to 1000 CM 4AF

For Transport (without Outlets) Vertical mounting

Cat. n°	KSA250CM4AF	KSA400CM4AF	KSA630CM4AF	KSA1000CM4AF
Compatible with	KSA100 to 250	KSA400	KSA500 to 1000	KSA500 to 1000
A in the line (mm)	800 to 1900	800 to 1900	800 to 1900	800 to 1900
Rating (A)	250	400	630	1000
Polarity	3L + N + PE	3L + N + PE	3L + N + PE	3L + N + PE

Characteristics				
Fire Barrier	Yes	Yes	Yes	Yes
Fire Barrier Position	Minimum 400 mm from the egde	Minimum 400 mm from the egde	Minimum 400 mm from the egde	Minimum 400 mm from the egde

Additional Characteristics				
IP	IP55	IP55	IP55	IP55
Color	White	White	White	White
Weight (kg)	8,2	11	31	37
Selling Unit	1	1	1	1
MOQ	1	1	1	1

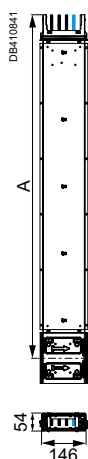

KSA100 to 400 CM 4A



KSA630CM4A to KSA1000CM4A

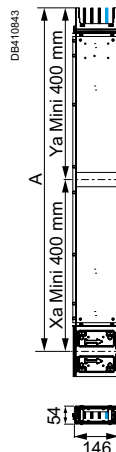

KSA250CM4AF to KSA400CM4AF

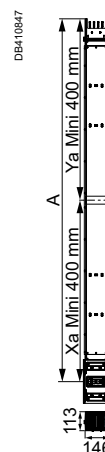

KSA630CM4AF to KSA1000CM4AF

F

Rising main offer

Fixing brackets and supports

For vertical installation

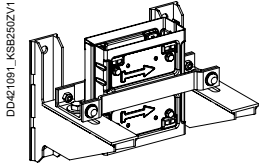

KSB100 to 400 ZV (C)

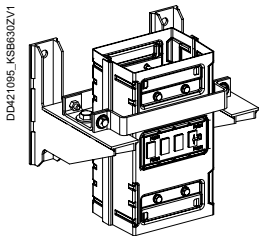

KSB500 to 1000 ZV (C)

To support all the run
Installed at the bottom of the riser

Cat. n°	KSB250ZV1	KSB400ZV1	KSB630ZV1	KSB1000ZV1
Compatible with	KSA100 to 400	KSA400	KSA500 to 1000	KSA500 to 1000
Rating (A)	250	400	630	1000
Polarity	-	-	-	-

Characteristics	KSB250ZV1	KSB400ZV1	KSB630ZV1	KSB1000ZV1
Max. permissible weight:	680 Kg	680 Kg	1760 Kg	1760 Kg

Additional Characteristics	KSB250ZV1	KSB400ZV1	KSB630ZV1	KSB1000ZV1
IP	IP55	IP55	IP55	IP55
Color	White	White	White	White
Weight (kg)	5,5	5,85	7,5	8
Selling Unit	1	1	1	1
MOQ	1	1	1	1

ZV1 Bottom supports: check max weight or height in Offer description

For vertical installation

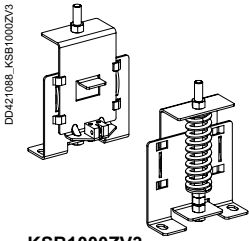

KSB1000ZV3

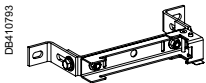

KSB1000ZV2

To support and guide the run at each floor
Spring hanger and fixing bracket

Cat. n°	KSB1000ZV3	KSB1000ZV2	KFBACA81200
Compatible with	KSA500 to 1000	KSA500 to 1000	KSA100 to 1000
Rating (A)	1000	1000	1000
Polarity	-	-	-

Characteristics	KSB1000ZV3	KSB1000ZV2	KFBACA81200
Max. permissible weight:	440 Kg	-	220 kg

Additional Characteristics	KSB1000ZV3	KSB1000ZV2	KFBACA81200
IP	IP55	IP55	-
Color	White	White	Galvanised
Weight (kg)	1,6	0,55	0,45
Selling Unit	1	1	1
MOQ	1	5	4

KSB1000ZV2: It is advice to use 1 guide per floor up to 3.5 meters high and 2 guides if higher than 3.5 meters
KSB1000ZV3: can be installed directly on the floor or on cantilever arm KFBACA81200

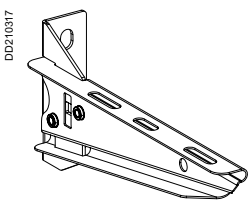

KFBACA81200

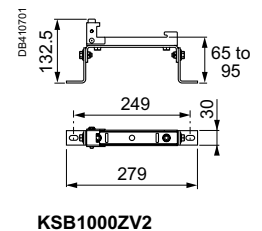
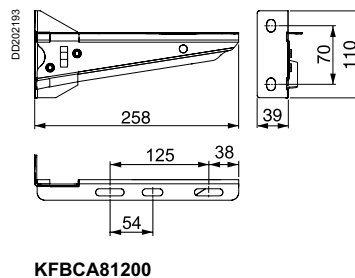
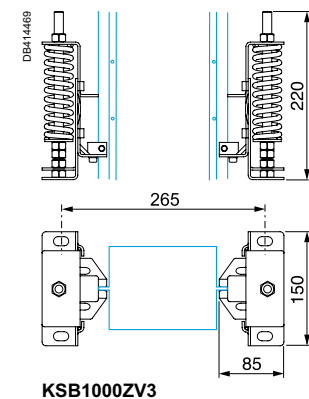
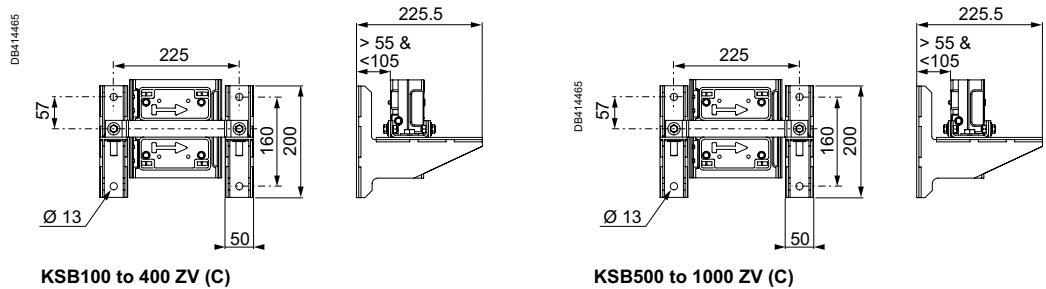

Rising main offer

Connectors and Tap-off units

Disconnection by opening the door

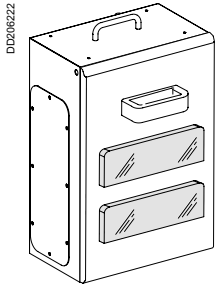

KSB160 SM •

Delivered equipped with 2 DIN Rails
For 18 mm modular devices ⁽¹⁾

Cat. n°	KSB160SM424	KSB160SM524
Compatible with	KSA100 to 1000	KSA100 to 1000

Rating (A)	160	160
Polarity	3L + N + PE	3L + PEN
Phase Diagram		

Cabling		
Protection Type (Not Supplied)	2 x 12 modules 18 mm (= 24)	2 x 12 modules 18 mm (= 24)

Body Material	Metal	Metal
Cable Output	2 lateral 1.5 mm steel cable plates 345 x 130	2 lateral 1.5 mm steel cable plates 345 x 130

Available Area (mm)	2 x (315 x 100)	2 x (315 x 100)
---------------------	-----------------	-----------------

Connection	Acti9 Terminals	Acti9 Terminals
------------	-----------------	-----------------

Maximum Rigid Cable Size (mm ²)	See Acti9 catalog	See Acti9 catalog
---	-------------------	-------------------

Maximum Flexible Cable Size (mm ²)	See Acti9 catalog	See Acti9 catalog
--	-------------------	-------------------

Supplied with blanking plate	Supplied with blanking plate
------------------------------	------------------------------

Additional Characteristics		
IP	IP55	IP55
Color	White	White
Weight (kg)	9	9
Selling Unit	1	1
MOQ	1	1

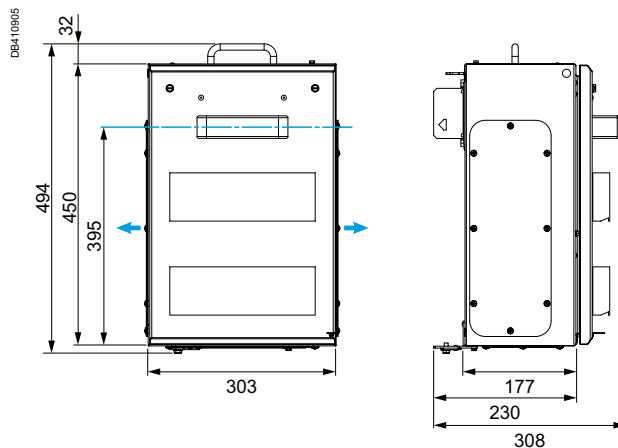

KSB160 SM •

F

Rising main offer

Connectors and Tap-off units

Switching with an extended rotary handle located on the door

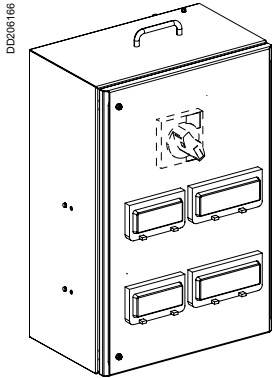

KSB250 SM428

To be equipped with a disconnector Compact INS/INV 250 and multiple Acti9 circuit breakers.
This tap-off units is mountable over the junction cover. Cable entries are positioned at the opposite site of the door. IP31

Cat. n° KSB250SM428
Compatible with KSA500 to 1000

Rating (A) 250
Polarity 3L + N + PE
Phase Diagram

Cabling

Device Type Level 1: Switch disconnector Compact INS/INV 250
(Not Supplied) Level 2: Acti9 circuit breakers (2 x 14 modules of 18 mm)

Body Material Metal
Cable Output A set of holes at the rear

Available 16 x Ø25.5 +
Area (mm) 3 x Ø40.5

Connection Acti9 Terminals

Maximum Rigid Cable Size (mm²) See Acti9 catalog
Maximum Flexible Cable Size (mm²) See Acti9 catalog

NSX250: Extended rotary handle
LV429338

Additional Characteristics

IP IP31
Color White
Weight (kg) 14
Selling Unit 1
MOQ 1

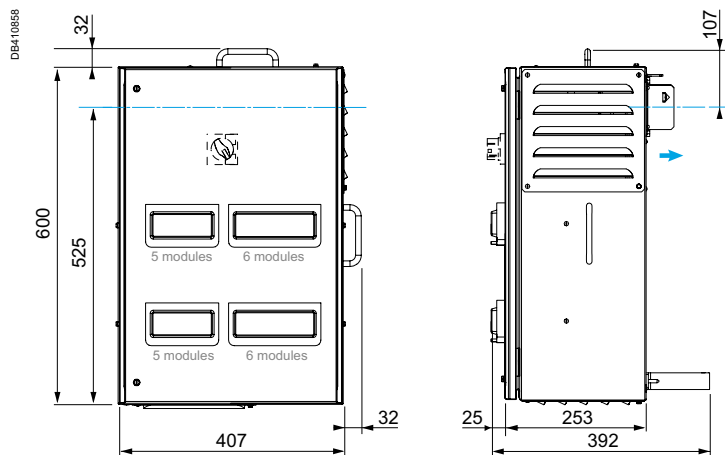

KSB250 SM •

Rising main offer

Connectors and Tap-off units

Switching with an extended rotary handle located on the door

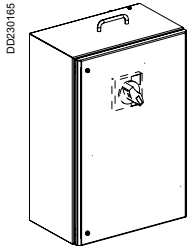

KSB250 DC 4

Delivered equipped with a mounting plate for 1 Circuit Breaker
For NSX Circuit breaker (Tap-off unit mountable over the junction unit)

Cat. n° **KSB250DC4SP**
Compatible with KSA100 to 1000

Rating (A) 250
Polarity 3L + N + PE
Phase Diagram

Cabling

Protection Type NSX250 - N, H, L
(Not Supplied)

Body Material Metal
Cable Output 2 lateral 1.5 mm steel
cable plates
245 x 130

Available 2 x (215 x 100)
Area (mm)

Connection On NSX Terminals

Maximum Rigid See NSX catalog
Cable Size (mm²)
Maximum Flexible See NSX catalog
Cable Size (mm²)

NSX250: Extended
rotary handle
LV429338

Additional Characteristics

IP IP55
Color White
Weight (kg) 15.8
Selling Unit 1
MOQ 1

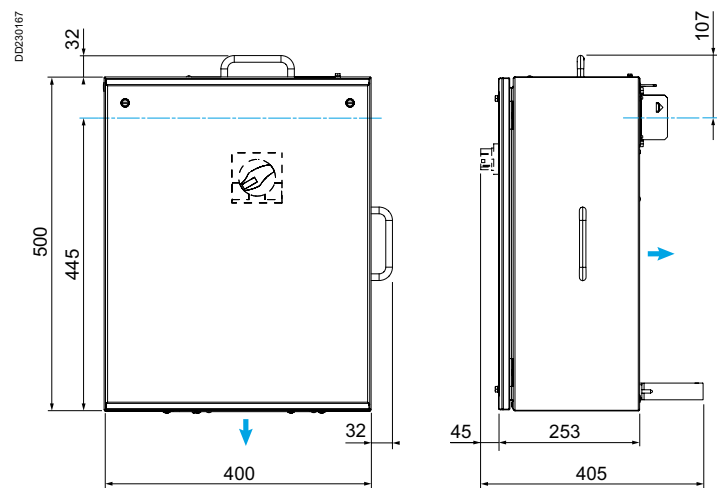

KSB250 DC 4

Canalis KS range

Missing link offer (Express delivery)

A selection of made-to-measure products in fast delivery

Description.....	page 189
Overview	page 191
Commercial numbers and dimensions.....	page 190

Description

Missing Link offer

From 100 to 1000 A

A missing link is generally the last element to be installed in a run. Dimensions are measured on site after the installation of all standard elements. It could also be an element to be delivered in shorter time after a change or a repair.

Missing link offer is a special service by Schneider Electric. It consists in dedicated commercial references of a made to measure element (a straight length or an elbow, with or without fire barrier) delivered in Express, on site, in a robust wooden box.

Some advice to correctly define your missing link.

Ideally select a straight section to be a Missing link.

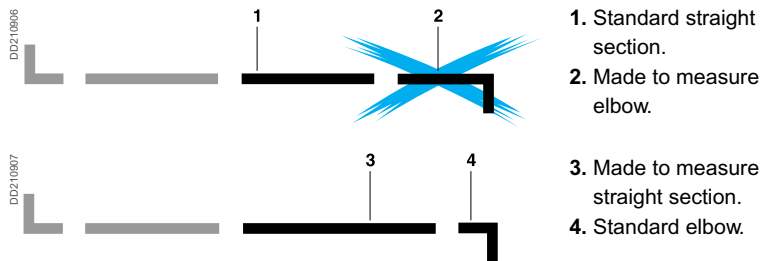

On the drawing, provide a minimum dimension of 700 mm to provide an adjustment of ± 200 mm on-site. The minimum length of straight sections being equal to 500 mm.

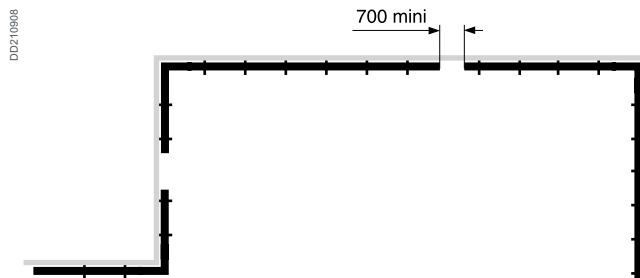

In order to provide for the place needed for undecided section, install the elbows and the sections attached to the elbows in each angle (support each assembly using 2 supports on each straight section).

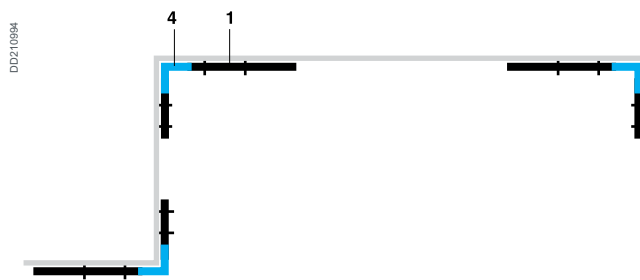

And then complete the layout with standard and made to measure straight sections.



Description

Missing Link offer

From 100 to 1000 A

Elbows – How to measure

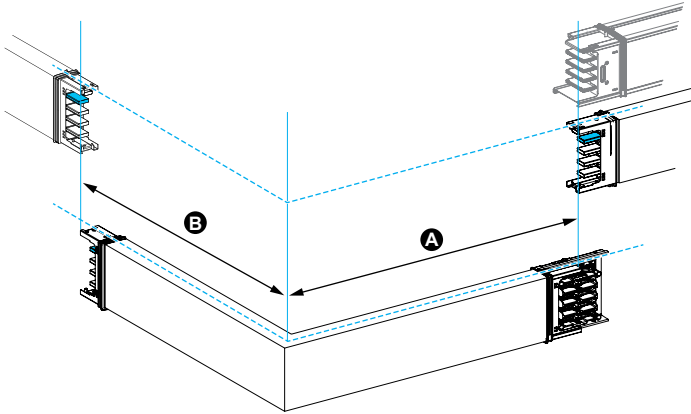

A = dimension is measured from the bottom edge of the element on the right up to the axis of **B** side.

B = dimension is measured from the bottom edge of the element on the left up to the axis of **A** side.

A and **B** = dimensions can be adjusted in increments of 5 mm, rounded down to the nearest multiple of 5 mm.

For example: measurement is 768 mm. **A** will be 765.

Place a piece of wood or equivalent against the extremity of the element **1** with a thickness of "e" mm (You can use the protective piece of wood delivered with the element).

Place a piece of wood or equivalent all along the element **2**.

With a laser or equivalent, measure the distance "L" between the side of element **2** to the extremity of element **1**.

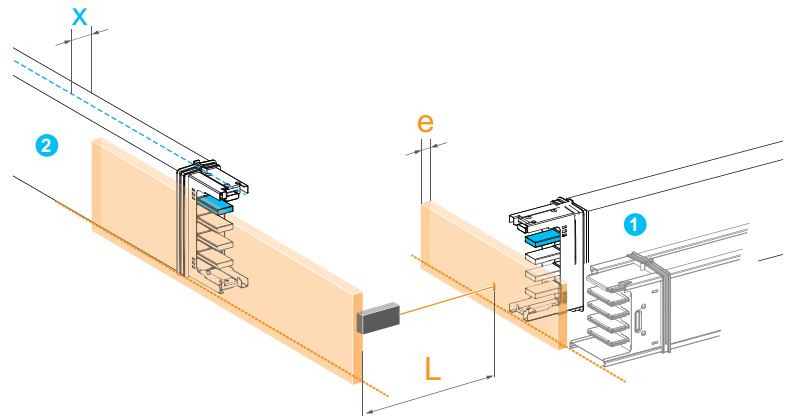

Calculate **A** of the elbow with the formula (mm): **A = L + e - x**

For KS100 to KS400 edgewise: x = 27 mm and for KS500 to KS1000: x = 61 - DLE and DLF elbows, or flatwise installation, x = 73 mm

Straight Length – How to measure

Both elements must be perfectly aligned.

Measure the distance between the bottom edge of each profile (right and left).

A dimension can be adjusted in increments of 5 mm, rounded down to the nearest multiple of 5 mm.

For example: measurement is 768 mm. **A** will be 765.

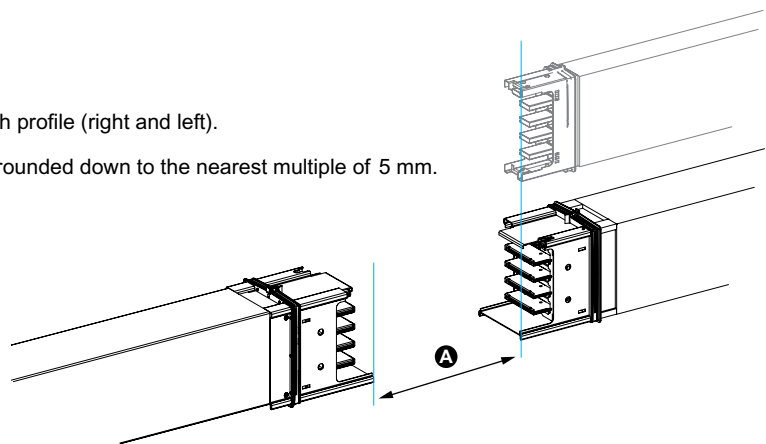

Busbar ratings (A)

100	160	250	400	500	630	800	1000 A
-----	-----	-----	-----	-----	-----	-----	--------

Straight lengths

Horizontal mounting

For transport (without outlets) - 3L+N+PE

Made-to-measure

500 to 1900 mm	KSA250ET4AM	KSA250ET4AM	KSA250ET4AM	KSA400ET4AM	KSA630ET4AM	KSA630ET4AM	KSA1000ET4AM	KSA1000ET4AM
Made-to-measure - With 1 fire barrier free positioning								
700 to 1900 mm	KSA250ET4AFM	KSA250ET4AFM	KSA250ET4AFM	KSA400ET4AFM	KSA630ET4AFM	KSA630ET4AFM	KSA1000ET4AFM	KSA1000ET4AFM

Change direction elements

Elbows - 3L+N+PE

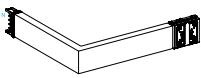
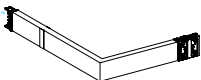
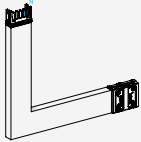
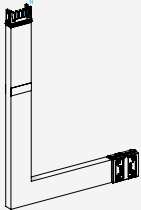
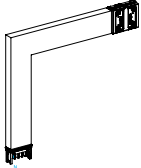
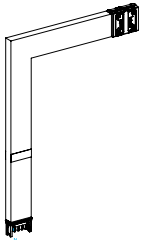
	A = (200 to 750) x B = (200 to 750)				A = (290 to 800) x B = (290 to 800)			
	KSA250DLC4AM	KSA250DLC4AM	KSA250DLC4AM	KSA400DLC4AM	KSA630DLC4AM	KSA630DLC4AM	KSA1000DLC4AM	KSA1000DLC4AM
	A = (250 to 750) x B = (700 to 1200)				A = (290 to 800) x B = (700 to 1200)			
With fire barrier	KSA250DLC4CFM	KSA250DLC4CFM	KSA250DLC4CFM	KSA400DLC4CFM	KSA630DLC4CFM	KSA630DLC4CFM	KSA1000DLC4CFM	KSA1000DLC4CFM
	A = (250 to 750) x B = (250 to 750)				A = (290 to 800) x B = (290 to 800)			
	KSA250DLE4AM	KSA250DLE4AM	KSA250DLE4AM	KSA400DLE4AM	KSA630DLE4AM	KSA630DLE4AM	KSA1000DLE4AM	KSA1000DLE4AM
	A = (250 to 750) x B = (700 to 1200)				A = (290 to 800) x B = (700 to 1200)			
With fire barrier	KSA250DLE4CFM	KSA250DLE4CFM	KSA250DLE4CFM	KSA400DLE4CFM	KSA630DLE4CFM	KSA630DLE4CFM	KSA1000DLE4CFM	KSA1000DLE4CFM
	A = (250 to 750) x B = (250 to 750)				A = (290 to 800) x B = (290 to 800)			
	KSA250DLF4AM	KSA250DLF4AM	KSA250DLF4AM	KSA400DLF4AM	KSA630DLF4AM	KSA630DLF4AM	KSA1000DLF4AM	KSA1000DLF4AM
	A = (250 to 750) x B = (700 to 1200)				A = (290 to 800) x B = (700 to 1200)			
With fire barrier	KSA250DLF4CFM	KSA250DLF4CFM	KSA250DLF4CFM	KSA400DLF4CFM	KSA630DLF4CFM	KSA630DLF4CFM	KSA1000DLF4CFM	KSA1000DLF4CFM



"KS.....": Reference specifically adapted to the rating of the busbar trunking

"KS.....": Compatible reference with the rating of the busbar trunking

Missing link offer (Express delivery)

Straight lengths

Made-to-measure

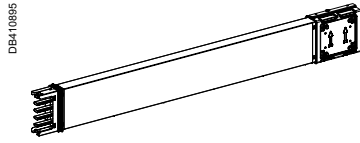

KSA100 to 400 ET4AM

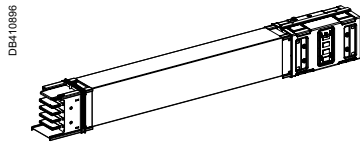

KSA500 to 1000 ET4AM

For Transport (without Outlets)
Horizontal mounting

Cat. n°	KSA250ET4AM	KSA400ET4AM	KSA630ET4AM	KSA1000ET4AM
Compatible with	KSA100 to 250	KSA400	KSA500 to 1000	KSA500 to 1000
A in the line (mm)	500 to 1900	500 to 1900	500 to 1900	500 to 1900
Rating (A)	250	400	630	1000
Polarity	3L + N + PE	3L + N + PE	3L + N + PE	3L + N + PE

Characteristics				
Fire Barrier	No	No	No	No

Additional Characteristics				
IP	IP55	IP55	IP55	IP55
Color	White	White	White	White
Weight (kg)	8	10	30	32,2
Selling Unit	1	1	1	1
MOQ	1	1	1	1

A dimension can be adjusted in increments of 5 mm. See A minimum and maximum.

To order, indicate for example: KSA400ETA4M, A = 710 mm

Made-to-measure - With 1 fire barrier

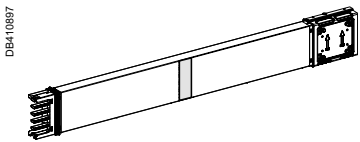

KSA100 to 400 ET4AFM

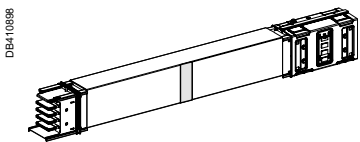

KSA500 to 1000 ET4AFM

For Transport (without Outlets)
Horizontal mounting

Cat. n°	KSA250ET4AFM	KSA400ET4AFM	KSA630ET4AFM	KSA1000ET4AFM
Compatible with	KSA100 to 250	KSA400	KSA500 to 1000	KSA500 to 1000
A in the line (mm)	800 to 1900	800 to 1900	800 to 1900	800 to 1900
Rating (A)	250	400	630	1000
Polarity	3L + N + PE	3L + N + PE	3L + N + PE	3L + N + PE

Characteristics				
Fire Barrier	Yes	Yes	Yes	Yes
Fire Barrier	Minimum 400 mm from the edge	Minimum 400 mm from the edge	Minimum 400 mm from the edge	Minimum 400 mm from the edge
Position				

Additional Characteristics				
IP	IP55	IP55	IP55	IP55
Color	White	White	White	White
Weight (kg)	8,2	10	30	37
Selling Unit	1	1	1	1
MOQ	1	1	1	1

A dimension can be adjusted in increments of 5 mm. See A minimum and maximum.

Fire barrier position is adjustable in increments of 10 mm respecting the Xa and Ya minimum.

To order, indicate for example: KSA400ETA4FM, A = 950mm, Xa = 450, Ya = 500

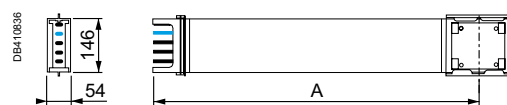

KSA100 to 400 ET •A

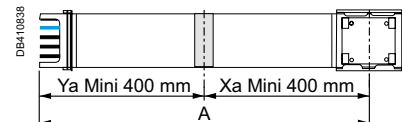

KSA100 to 400ET4AFM

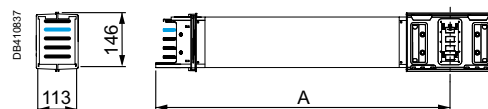

KSA500 to 1000 ET •A

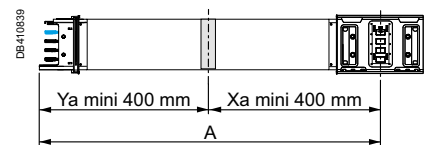

KSA500 to 1000ET4AFM

Missing link offer (Express delivery)

Change direction elements

Elbows

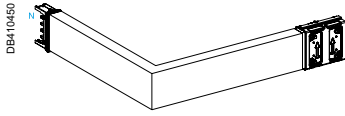

KSA100 to 400 DLC 4A

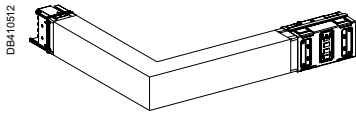

KSA500 to 1000 DLC 4A

To turn Right or Left at 90° (Edgewise position)
Sides A and B are made-to-measure

Cat. n°	KSA250DLC4AM	KSA400DLC4AM	KSA630DLC4AM	KSA1000DLC4AM
Compatible with	KSA100 to 250	KSA400	KSA500 to 1000	KSA500 to 1000
A in the line (mm)	400 to 1500	400 to 1500	580 to 1600	580 to 1600
Rating (A)	250	400	630	1000
Polarity	3L + N + PE	3L + N + PE	3L + N + PE	3L + N + PE

Dimensions

Dimensions	KSA250DLC4AM	KSA400DLC4AM	KSA630DLC4AM	KSA1000DLC4AM
A (mm)	200 to 750	200 to 750	290 to 800	290 to 800
B (mm)	200 to 750	200 to 750	290 to 800	290 to 800
Fire Barrier	No	No	No	No

Additional Characteristics

Additional Characteristics	KSA250DLC4AM	KSA400DLC4AM	KSA630DLC4AM	KSA1000DLC4AM
IP	IP55	IP55	IP55	IP55
Color	White	White	White	White
Weight (kg)	18	20	17	17,5
Selling Unit	1	1	1	1
MOQ	1	1	1	1

A and B dimensions can be adjusted in increments of 5 mm. See A and B minimum and maximum.

To order, indicate for example: KSA400DLC4AM, A = 500, B = 500

Elbows

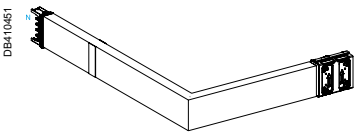

KSA100 to 400 DLC 4CF

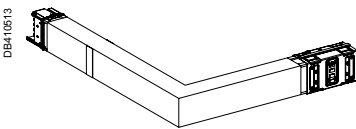

KSA500 to 1000 DLC 4CF

To turn Right or Left at 90° (Edgewise position)
Sides A and B are made-to-measure including 1 Fire Barrier (FB) on 1 side

Cat. n°	KSA250DLC4CFM	KSA400DLC4CFM	KSA630DLC4CFM	KSA1000DLC4CFM
Compatible with	KSA100 to 250	KSA400	KSA500 to 1000	KSA500 to 1000
A in the line (mm)	900 to 1950	900 to 1950	980 to 2000	980 to 2000
Rating (A)	250	400	630	1000
Polarity	3L + N + PE	3L + N + PE	3L + N + PE	3L + N + PE

Dimensions

Dimensions	KSA250DLC4CFM	KSA400DLC4CFM	KSA630DLC4CFM	KSA1000DLC4CFM
A (mm)	(200 to 750) or (700 to 1200) if FB	(200 to 750) or (700 to 1200) if FB	(290 to 800) or (700 to 1200) if FB	(290 to 800) or (700 to 1200) if FB
B (mm)	(200 to 750) or (700 to 1200) if FB	(200 to 750) or (700 to 1200) if FB	(290 to 800) or (700 to 1200) if FB	(290 to 800) or (700 to 1200) if FB
Fire Barrier	Yes	Yes	Yes	Yes
Fire Barrier Position	Either on side A or B	Either on side A or B	Either on side A or B	Either on side A or B

Additional Characteristics

Additional Characteristics	KSA250DLC4CFM	KSA400DLC4CFM	KSA630DLC4CFM	KSA1000DLC4CFM
IP	IP55	IP55	IP55	IP55
Color	White	White	White	White
Weight (kg)	15	17	12	12,5
Selling Unit	1	1	1	1
MOQ	1	1	1	1

A and B dimensions can be adjusted in increments of 5 mm. See A and B minimum and maximum. One Fire barrier can be positioned on or side A or on side B. Fire barrier position is adjustable in increments of 10 mm respecting the Xa and Ya or Xb and Yb minimum

To order, indicate for example: KSA400DLC4CFM, A = 500, B = 900, Xb = 450, Yb = 450

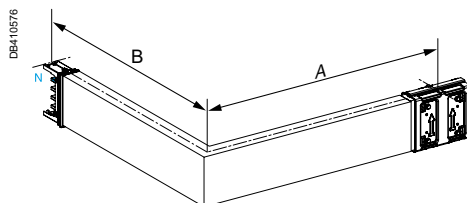

KSA100 to 400 DLC 4A

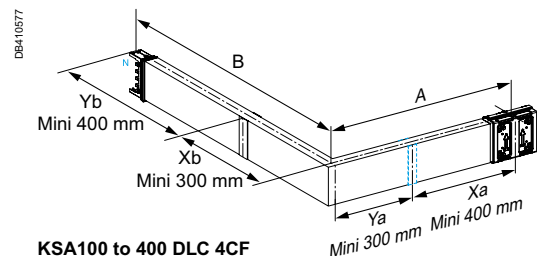

KSA100 to 400 DLC 4CF

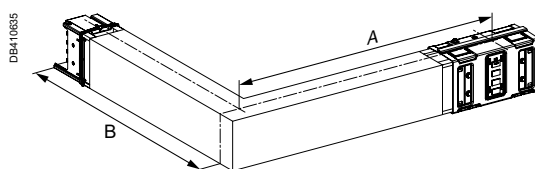

KSA500 to 1000 DLC 4A

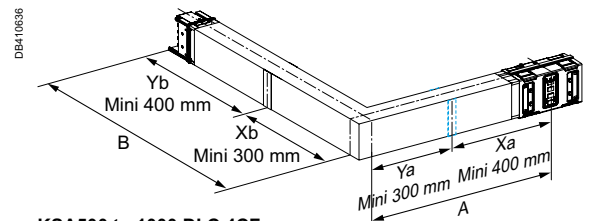

KSA500 to 1000 DLC 4CF

Missing link offer (Express delivery)

Change direction elements

Elbows

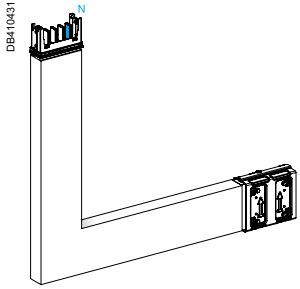

KSA100 to 400 DLE 4A

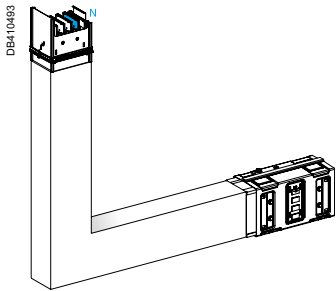

KSA500 to 1000 DLE 4A

To go Upward at 90° (Edgewise position)
Sides A and B are made-to-measure

Cat. n°	KSA250DLE4AM	KSA400DLE4AM	KSA630DLE4AM	KSA1000DLE4AM
Compatible with	KSA100 to 250	KSA400	KSA500 to 1000	KSA500 to 1000
A in the line (mm)	500 to 1500	500 to 1500	580 to 1600	580 to 1600
Rating (A)	250	400	630	1000
Polarity	3L + N + PE	3L + N + PE	3L + N + PE	3L + N + PE

Dimensions				
A (mm)	250 to 750	250 to 750	290 to 800	290 to 800
B (mm)	250 to 750	250 to 750	290 to 800	290 to 800
C (mm)	-	-	-	-
D (mm)	-	-	-	-
Fire Barrier	No	No	No	No
Fire Barrier Position	-	-	-	-

Additional Characteristics				
IP	IP55	IP55	IP55	IP55
Color	White	White	White	White
Weight (kg)	34	42	19	19,5
Selling Unit	1	1	1	1
MOQ	1	1	1	1

A and B dimensions can be adjusted in increments of 5 mm. See A and B minimum and maximum.

To order, indicate for example: KSA400DLE4AM, A = 500, B = 500

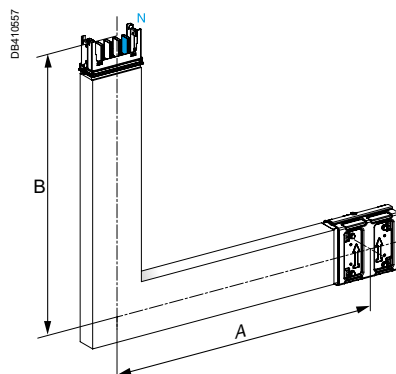

KSA100 to 400 DLE 4A

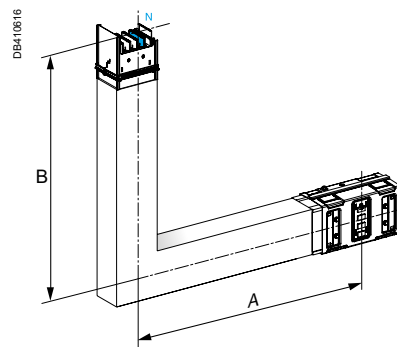

KSA500 to 1000 DLE 4A

Missing link offer (Express delivery)

Change direction elements

Elbows

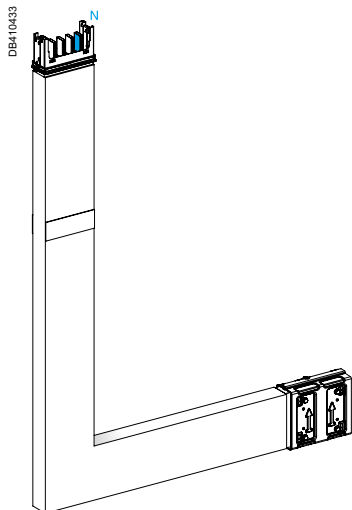

KSA100 to 400 DLE 4CF

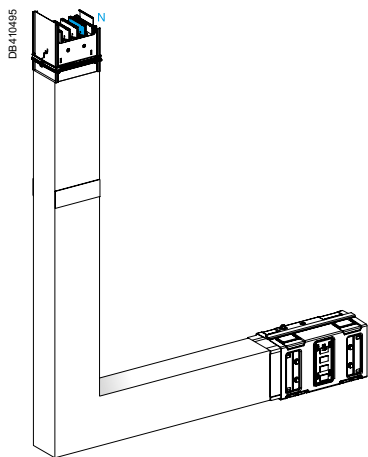

KSA500 to 1000 DLE 4CF

To go Upward at 90° (Edgewise position)
Sides A and B are made-to-measure including 1 Fire Barrier (FB) on 1 side

Cat. n°	KSA250DLE4CFM	KSA400DLE4CFM	KSA630DLE4CFM	KSA1000DLE4CFM
Compatible with	KSA100 to 250	KSA400	KSA500 to 1000	KSA500 to 1000
A in the line (mm)	950 to 1950	950 to 1950	990 to 2000	990 to 2000
Rating (A)	250	400	630	1000
Polarity	3L + N + PE	3L + N + PE	3L + N + PE	3L + N + PE

Dimensions

A (mm)	(250 to 750) or (700 to 1200) if FB	(250 to 750) or (700 to 1200) if FB	(290 to 800) or (700 to 1200) if FB	(290 to 800) or (700 to 1200) if FB
B (mm)	(250 to 750) or (700 to 1200) if FB	(250 to 750) or (700 to 1200) if FB	(290 to 800) or (700 to 1200) if FB	(290 to 800) or (700 to 1200) if FB
C (mm)	-	-	-	-
D (mm)	-	-	-	-
Fire Barrier	Yes	Yes	Yes	Yes
Fire Barrier Position	Either on side A or B	Either on side A or B	Either on side A or B	Either on side A or B

Additional Characteristics

IP	IP55	IP55	IP55	IP55
Color	White	White	White	White
Weight (kg)	20	24	11	11,5
Selling Unit	1	1	1	1
MOQ	1	1	1	1

A and B dimensions can be adjusted in increments of 5 mm. See A and B minimum and maximum. One Fire barrier can be positioned on side A or on side B. Fire barrier position is adjustable in increments of 10 mm respecting the Xa and Ya or Xb and Yb minimum
To order, indicate for example: KSA400DLE4CFM, A = 500, B = 900, Xb = 450, Yb = 450

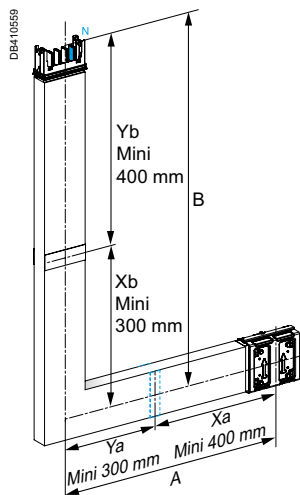

KSA100 to 400 DLE 4CF

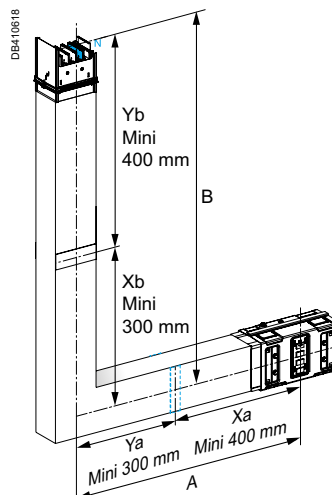

KSA500 to 1000 DLE 4CF



Missing link offer (Express delivery)

Change direction elements

Elbows

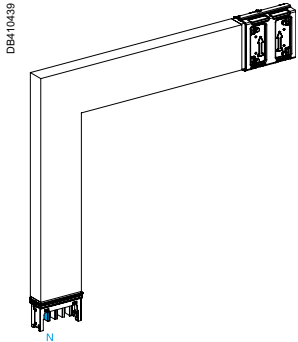

To go Downward at 90° (Edgewise position)
Sides A and B are made-to-measure

Cat. n°	KSA250DLF4AM	KSA400DLF4AM	KSA630DLF4AM	KSA1000DLF4AM
Compatible with	KSA100 to 250	KSA400	KSA500 to 1000	KSA500 to 1000
A in the line (mm)	500 to 1500	500 to 1500	580 to 1600	580 to 1600
Rating (A)	250	400	630	1000
Polarity	3L + N + PE	3L + N + PE	3L + N + PE	3L + N + PE

KSA100 to 400 DLF 4A

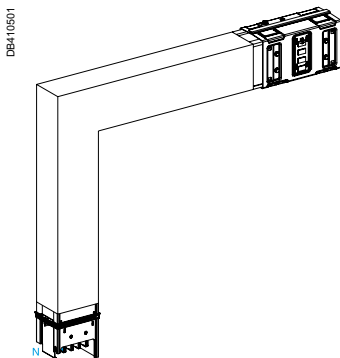

Dimensions				
A (mm)	250 to 750	250 to 750	290 to 800	290 to 800
B (mm)	250 to 750	250 to 750	290 to 800	290 to 800
C (mm)	-	-	-	-
D (mm)	-	-	-	-
Fire Barrier	No	No	No	No
Fire Barrier Position	-	-	-	-

KSA500 to 1000 DLF 4A

Additional Characteristics				
IP	IP55	IP55	IP55	IP55
Color	White	White	White	White
Weight (kg)	34	42	19	19,5
Selling Unit	1	1	1	1
MOQ	1	1	1	1

A and B dimensions can be adjusted in increments of 5 mm. See A and B minimum and maximum.

To order, indicate for example: KSA400DLF4AM, A = 500, B = 500

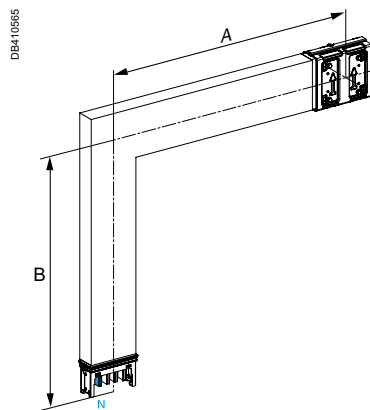

KSA100 to 400 DLF 4A

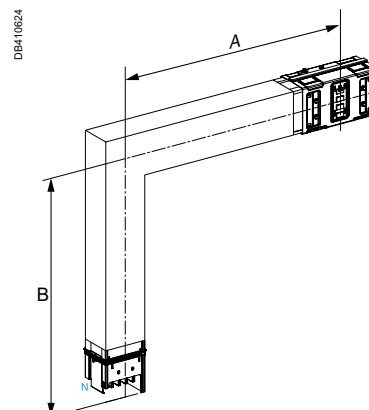

KSA500 to 1000 DLF 4A

Missing link offer (Express delivery)

Change direction elements

Elbows

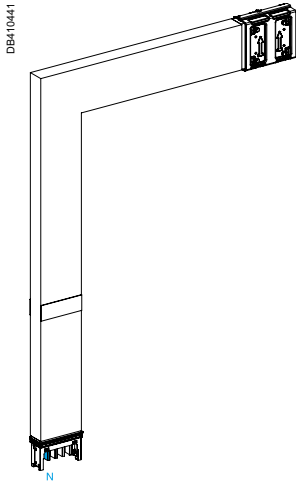

KSA100 to 400 DLF 4CF

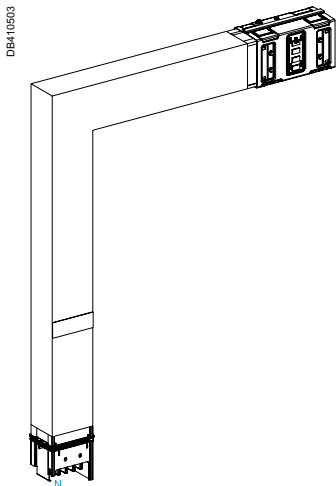

KSA500 to 1000 DLF 4CF

To go Downward at 90° (Edgewise position)
Sides A and B are made-to-measure including 1 Fire Barrier (FB) on 1 side

Cat. n°	KSA250DLF4CFM	KSA400DLF4CFM	KSA630DLF4CFM	KSA1000DLF4CFM
Compatible with	KSA100 to 250	KSA400	KSA500 to 1000	KSA500 to 1000
A in the line (mm)	950 to 1950	950 to 1950	990 to 2000	990 to 2000
Rating (A)	250	400	630	1000
Polarity	3L + N + PE	3L + N + PE	3L + N + PE	3L + N + PE

Dimensions

A (mm)	(250 to 750) or (700 to 1200) if FB	(250 to 750) or (700 to 1200) if FB	(290 to 800) or (700 to 1200) if FB	(290 to 800) or (700 to 1200) if FB
B (mm)	(250 to 750) or (700 to 1200) if FB	(250 to 750) or (700 to 1200) if FB	(290 to 800) or (700 to 1200) if FB	(290 to 800) or (700 to 1200) if FB
C (mm)	-	-	-	-
D (mm)	-	-	-	-
Fire Barrier	Yes	Yes	Yes	Yes
Fire Barrier Position	Either on side A or B	Either on side A or B	Either on side A or B	Either on side A or B

Additional Characteristics

IP	IP55	IP55	IP55	IP55
Color	White	White	White	White
Weight (kg)	20	24	11	11,5
Selling Unit	1	1	1	1
MOQ	1	1	1	1

A and B dimensions can be adjusted in increments of 5 mm. See A and B minimum and maximum. One Fire barrier can be positioned on side A or on side B. Fire barrier position is adjustable in increments of 10 mm respecting the Xa and Ya or Xb and Yb minimum
 To order, indicate for example: KSA400DLF4CFM, A = 500, B = 900, Xb = 450, Yb = 450

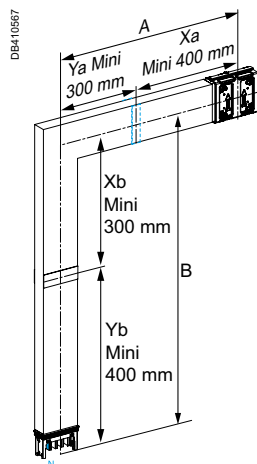

KSA100 to 400 DLF 4CF

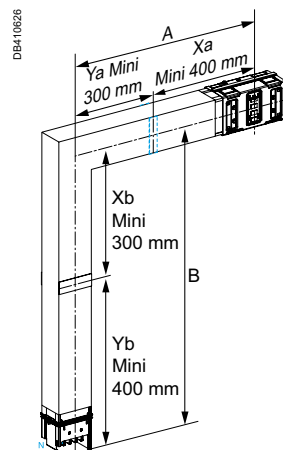

KSA500 to 1000 DLF 4CF



Simplified study and design guide

Simplified study guide for the design of a power distribution line in Canalis busbar trunking.....page 199

Simplified design guide:
Determining the degree of protection.....page 204

for the design of a power distribution line in Canalis busbar trunking

Except in extreme atmospheres, there's no longer any need to hesitate. Canalis can be installed anywhere!

"The chronology described below aims to present the steps for the execution of a simple installation. For a detailed study, it is recommended to use appropriate tools, certified by the inspection organisations, in accordance with local installation standards. The **Ecodial** software, published by Schneider Electric, meets this need".

A study grid, enabling you to note your choices and store them, is available on page 202 (to be detached or photocopied).

1 IDENTIFY EXTERNAL INFLUENCES

The ambient temperature, presence of dust, condensation water, etc. contribute to the definition of the degree of protection required by the room in which electrical installation will be performed.

Canalis KS and KN prefabricated electrical busbar trunking are IP55 by design and can be installed in nearly all premises. (See description of the degree of protection (IP) page 204).

2 LOCATION OF LOADS AND TRUNKING INSTALLATION METHOD

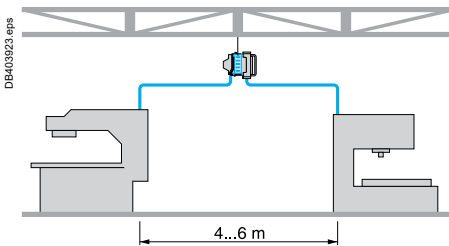

The layout of the distribution lines depends on the location of the loads, the location of the power supply source and the mounting possibilities.

- A single distribution line serves an area of 4 to 6 metres long.
- Load protection is located in the tap-off unit positioned as close as possible to the load.
- A single Canalis busbar trunking system powers a series of loads of various capacities.

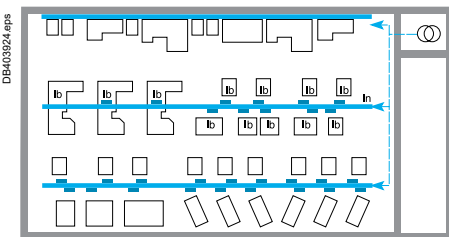

3 POWER BALANCE: CALCULATION OF CURRENTS CONSUMED ON EACH DISTRIBUTION LINE

Calculation of the total operating current (I_n) consumed on a line:

$$I_n \text{ operating} = \sum I_b$$

I_b = current consumed by each load

BUT

Since the loads do not all operate at the same time and are not constantly at full capacity, it is necessary to allow for the growth factor or coincidence factor (K_s):

$$I_n \text{ operating} = \sum (I_b \times K_s).$$

The diversity factor K_s depends on the type and number of loads.

Application	Number of loads	K_s factor
Lighting, heating	-	1
Distribution (Mechanical workshop)	2...3	0.9
	4...5	0.8
	6...9	0.7
	10...40	0.6
	40 and more	0.5

MOREOVER

For industrial installations, take into account growth in the installed machinery base. A 20% margin is recommended: $I_n \text{ operating} = \sum I_b \times K_s \times 1.2$



Simplified study guide

for the design of a power distribution line in Canalis busbar trunking

4 CHOICE OF CANALIS TRUNKING CORRESPONDING TO I_n OPERATING

By calculating " I_n " operating you can determine " I_n trunking" and hence the trunking to be installed.

Select the trunking for which the " I_n trunking" is directly greater than " I_n operating".

Table 1

Total operating current I_n (A)	Trunking
40	KNA40
63	KNA63
100	KNA100 or KSA100
160	KNA160 or KSA160
250	KSA250
400	KSA400
500	KSA500
630	KSA630
800	KSA800
1000	KSA1000

5 TEMPERATURE DERATING. CALCULATION OF I_z : PERMISSIBLE CURRENT I_n TRUNKING

Canalis trunkings are designed to operate in an ambient temperature of 35°C.

Above this temperature, the trunking should be derated as per the following table.

Permissible current according to ambient temperature	I_z					
Ambient temperature	< 35	35	40	45	50	55
K1 factor	None	1	0.97	0.94	0.91	0.87

Example: Canalis trunking KSA400 A at 45°C: $I_z = I_n \text{ trunking} \times K1 = 400 \times 0.94 = 376 \text{ A}$.

Check that $I_z > I_n$ operating and check the actual reserve. If necessary, select the next larger trunking.

6 DERATING ACCORDING TO INSTALLATION METHOD

Canalis KS trunking is designed to be installed edgewise. However, it can also be mounted flat **WITHOUT** derating.

7 OVERLOAD PROTECTION

To allow extensions at any time, the prefabricated trunkings are generally protected at nominal current " I_n trunking" (or at permissible current I_z if the K1 factor is applied according to the ambient temperature).

Depending on the type of protective device adopted, determine the standardised nominal current " I_n protection" of the overload protection device such that:

$I_n \text{ protection} \leq I_z / K2$	K2: Factor specific to the type of protective device
	Protection by circuit breaker: $K2 = 1$
	Protection by gG/gI fuses: $K2 = 1.1$

Choose the equal or immediately lower standardised rating I_n (protection).

Fuses: the typical ratings are given following the series of characteristic numbers of the "Renard" series. Example: 40 - 50 - 63 - 80 - 100 - 125 - 160 - 200, etc

Circuit breakers: the typical ratings found at Schneider Electric are, for example: 10-16-20-25-32-40-50-63-80-100-125-160-250-400-630, etc.

Finally, confirm the following condition: I_n standardised protection $\geq I_n$ operating. If this is not the case, choose the immediately larger trunking and adjust the calculations.

Simplified study guide

for the design of a power distribution line in Canalis busbar trunking

8 VERIFICATION OF VOLTAGE DROP

The voltage drop between the source and any point of use must not exceed the values in the following table:

Table 2

Installation supplied by a distribution network	Lighting	Other application
LV public system	3%	5%
HV voltage	6%	8%

The line-to-line voltage drop, during operation, is indicated in volts per 100 metre per ampere (V/100 m/A), at 50 Hz, with distributed loads on the Canalis line. In the case of a load concentrated at the end of a line, the value of the voltage drop is twice the indicated value.

Table 3

For a power factor ϕ of	KS	100 A	160 A	250 A	400 A	500 A	630 A	800 A	1000 A
1	V/100 m/A	0.138	0.067	0.034	0.018	0.013	0.011	0.008	0.005
0.9	V/100 m/A	0.130	0.066	0.036	0.022	0.014	0.013	0.009	0.007
0.8	V/100 m/A	0.118	0.061	0.035	0.022	0.014	0.013	0.009	0.007
0.7	V/100 m/A	0.106	0.056	0.034	0.021	0.013	0.012	0.009	0.008

This table applies to the three-phase network. To obtain the single-phase voltage drop, the three-phase voltage drop shown above is divided by 1.732. Check that the calculated voltage drop is < to the maximum voltage drop wanted.

9 PROTECTION AGAINST SHORT CIRCUITS

For standard installations with installed capacities of up to 630 kVA, by using the Schneider Electric product offering, the low-voltage electrical switchboard, circuit breakers and even Canalis trunking, your installation can be sized to cope with all levels of short circuits encountered.

To verify the correct configuration of your installation (Icc up to 150 kA), refer to the coordination tables pages 221 to 222.

We also invite you to discover Ecodial, our design and computation software dedicated to low-voltage electrical networks (choice of circuit breaker type, calculation of breaking capacity, short-circuit currents, voltage drops, selection of cables, etc.). Ask your Schneider Electric representative about it.

Simplified study guide

for the design of a power distribution line in Canalis busbar trunking

1 IDENTIFY EXTERNAL INFLUENCES

Minimum IP of equipment installed in the room:



2 LOCATION OF LOADS AND TRUNKING INSTALLATION METHOD

Row spacing (m)	Row(s) of receivers		
From 2 to 6 m	1	2	3
Canalis line(s) to be installed	1	1	2
> 6 m	1	2	3
Canalis line(s) to be installed	1	2	3

EXAMPLE

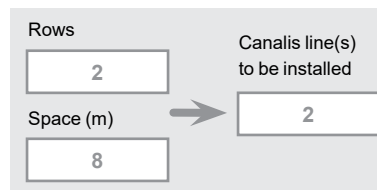

YOUR INSTALLATION

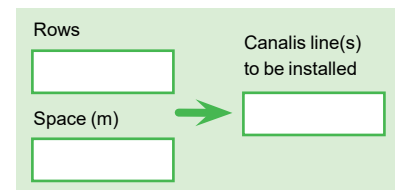

3 POWER BALANCE: CALCULATION OF CURRENTS CONSUMED ON EACH DISTRIBUTION LINE

	EXAMPLE	LINE 1	LINE 2	LINE 3	LINE 4
No. of loads	6	<input type="text"/>	<input type="text"/>	<input type="text"/>	<input type="text"/>
	X	X	X	X	X
Average current Ib (A)	50	<input type="text"/>	<input type="text"/>	<input type="text"/>	<input type="text"/>
	X	X	X	X	X
Diversity factor Ks	0.7	<input type="text"/>	<input type="text"/>	<input type="text"/>	<input type="text"/>
	X	X	X	X	X
Reserve factor (e.g. 1.2)	1.2	<input type="text"/>	<input type="text"/>	<input type="text"/>	<input type="text"/>
	=	=	=	=	=
In operating (A)	252	<input type="text"/>	<input type="text"/>	<input type="text"/>	<input type="text"/>

4 CHOICE OF CANALIS TRUNKING CORRESPONDING TO In

	EXAMPLE	LINE 1	LINE 2	LINE 3	LINE 4
Trunking to be installed <small>Table 1</small>	KS400	<input type="text"/>	<input type="text"/>	<input type="text"/>	<input type="text"/>
In trunking (A) <small>Table 1</small>	400	<input type="text"/>	<input type="text"/>	<input type="text"/>	<input type="text"/>

Check I_z > I_{n operating}

for the design of a power distribution line in Canalis busbar trunking

5 TEMPERATURE DERATING. CALCULATION OF I_z : PERMISSIBLE CURRENT IN TRUNKING

	EXAMPLE	LINE 1	LINE 2	LINE 3	LINE 4
T° ambient (°c)	45				
Derating factor K1	0.94				
I_z (A) = I_n trunking * K1 = permissible current	376				

Check

6 DERATING ACCORDING TO INSTALLATION METHOD

No derating for Canalis KS placed flat or upright.

7 OVERLOAD PROTECTION

	EXAMPLE	LINE 1	LINE 2	LINE 3	LINE 4
	Trunking protection	Trunking protection	Trunking protection	Trunking protection	Trunking protection
	<input type="checkbox"/> Fuses <input type="checkbox"/> CB*	<input type="checkbox"/> Fuses <input type="checkbox"/> CB*	<input type="checkbox"/> Fuses <input type="checkbox"/> CB*	<input type="checkbox"/> Fuses <input type="checkbox"/> CB*	<input type="checkbox"/> Fuses <input type="checkbox"/> CB*
K2	1.1 1				
I_z (A)	376				
I_n protection	341.8 376				
I_n standardised of protective device	315 400 set at 376				

*Circuit breaker
Check in operating $\leq I_z$

8 VERIFICATION OF VOLTAGE DROP

	EXAMPLE	LINE 1	LINE 2	LINE 3	LINE 4
Three-phase network voltage (V)	415				
Max. voltage drop %	5% Tb2	X	X	X	X
Max. voltage drop (V)	20.75				
Length (m) of Canalis line	50 (a)				
Power factor	0.9				
Voltage drop (V/100m/A) Tb3	0.022 (b)				
Voltage drop (V) (a/100) x b x "In trunking"	4.4				
Voltage drop (V) x 0.866	5.08				
Voltage drop (V) x 2	8.80				

Check. — Check. — Check.

9 PROTECTION FROM SHORT-CIRCUITS

Refer to the coordination tables on pages 221 to 222

Simplified design guide

Determining the degree of protection

Standard IEC 60364-5-51 categorises a large number of external influences to which electrical installations can be subjected, for instance the presence of water, solid objects, shocks, vibrations and corrosive substances.

The importance of these influences depends on the installation conditions.

For example, the presence of water can vary from a few drops to total immersion.

Degree of protection IP

Standard IEC 60529 (February 2001) indicates the degree of protection provided by electrical equipment enclosures against accidental direct contact with live parts and against the ingress of solid foreign objects or water.

This standard does not apply to protection against the risk of explosion or conditions such as humidity, corrosive gases, fungi or vermin.

The IP code comprises 2 characteristic numerals and may include an additional letter when the actual protection of persons against direct contact with live parts is better than that indicated by the first numeral.

The first numeral characterises the protection of the equipment against penetration of solid objects and the protection of people.

The second numeral characterises the protection of the equipment against penetration of water with harmful effects.

Remarks concerning the degree of protection IP

- The degree of protection IP must always be read and understood numeral by numeral and not as a whole.

For example, an IP31 enclosure is suitable for an environment that requires a minimum degree of protection IP21. However an IP30 wall-mount enclosure is not suitable.

- The degrees of protection indicated in this catalogue are valid for the enclosures as presented. However, the indicated degree of protection is guaranteed only when the installation and device mounting are carried out in accordance with professional standard practice.

Additional letter

Protection of persons against direct contact with live parts.

The additional letter is used only if the actual protection of persons is higher than that indicated by the first characteristic numeral of the IP code.

If only the protection of persons is of interest, the two characteristic numerals are replaced by the letter "X", e.g. IPXXB.

Degree of protection IK

Standard IEC 62262 defines a coding system (IK code) indicating the degree of protection provided by electrical equipment enclosures against external mechanical impact.

Installation standard IEC 60364 provides a cross-reference between the various degrees of protection and the environmental conditions classification, relating to the selection of equipment according to external factors.

IK** code

The IK code comprises 2 characteristic numerals (e.g. IK05).

Practical guide UTE C 15-103 shows, in the form of tables, the characteristics required for electrical equipment (including minimum degrees of protection), according to the locations in which they are installed.

Simplified design guide

Determining the degree of protection

Meaning of the numerals and letters representing the degree of protection IP

1st characteristic numeral: corresponds to protection of equipment against penetration of solid objects and protection of persons against direct contact with live parts.

Protection of equipment	Protection of persons		
Non-protected	Non-protected	0	
Protected against the penetration of solid objects having a diameter greater than or equal to 50 mm.	Protected against direct contact with the back of the hand (accidental contact).	1	
Protected against the penetration of solid objects having a diameter greater than or equal to 12.5 mm.	Protected against direct finger contact.	2	
Protected against the penetration of solid objects having a diameter greater than or equal to 2.5 mm.	Protected against direct contact with a 2.5 mm diameter tool.	3	
Protected against the penetration of solid objects having a diameter greater than 1 mm.	Protected against direct contact with a 1 mm diameter wire.	4	
Dust protected (no harmful deposits).	Protected against direct contact with a 1 mm diameter wire.	5	
Dust tight.	Protected against direct contact with a 1 mm diameter wire.	6	

2nd characteristic numeral: corresponds to protection of equipment against penetration of water with harmful effects.

Protection of equipment			
Non-protected		0	
Protected against vertical dripping water (condensation).		1	
Protected against dripping water at an angle of up to 15°.		2	
Protected against rain at an angle of up to 60°.		3	
Protected against splashing water in all directions.		4	
Protected against water jets in all directions.		5	
Protected against powerful jets of water and waves.		6	
Protected against the effects of temporary immersion.		7	
Protected against the effects of prolonged immersion under specified conditions.		8	

Additional letter

Corresponds to protection of persons against direct contact with live parts.

A	With the back of the hand.
B	With the finger.
C	With a 2.5 mm diameter tool.
D	With a 1.0 mm diameter tool.

Degrees of protection IK against mechanical impact

The IK code comprises 2 characteristic numerals corresponding to a value of impact energy, in joules.

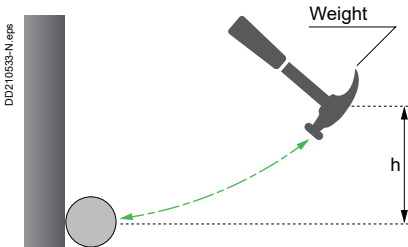

	Weight (kg)	Height (cm)	Energy (J)
00	Non-protected		
01	0.20	7.50	0.15
02		10	0.20
03		17.50	0.35
04		25	0.50
05		35	0.70
06	0.50	20	1
07		40	2
08	1.70	30	5
09	5	20	10
10		40	20

The Canalis KN and KS busbar trunking products are designed to provide IP55D and IK08 protection.

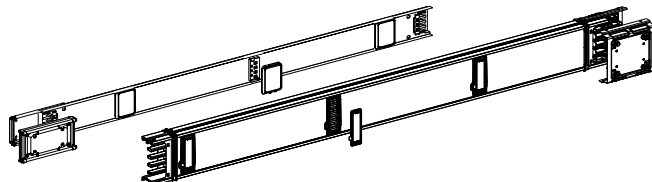

Characteristics and recommendations

Characteristics and recommendations

Technical specifications	page 208
Electrical characteristics	page 210
Recommendations for special applications	page 212
Coordination	page 215
Installation	page 224
Busbar trunking for medium power distribution	page 225
Storage	page 232
Busbar trunking for medium power distribution	page 233
Maintenance	page 234
Special applications	page 236
Direct current	page 237
Frequencies 400 Hz	page 238
Fire resistance	page 239
Harmonic currents	page 240
Sprinkler test certification	page 244
Measurements and metering:	
Canalis part of StruxureWare	page 246
Replacement table	page 247

Characteristics and recommendations

Technical specifications

Horizontal trunking

PD202340_rWeps

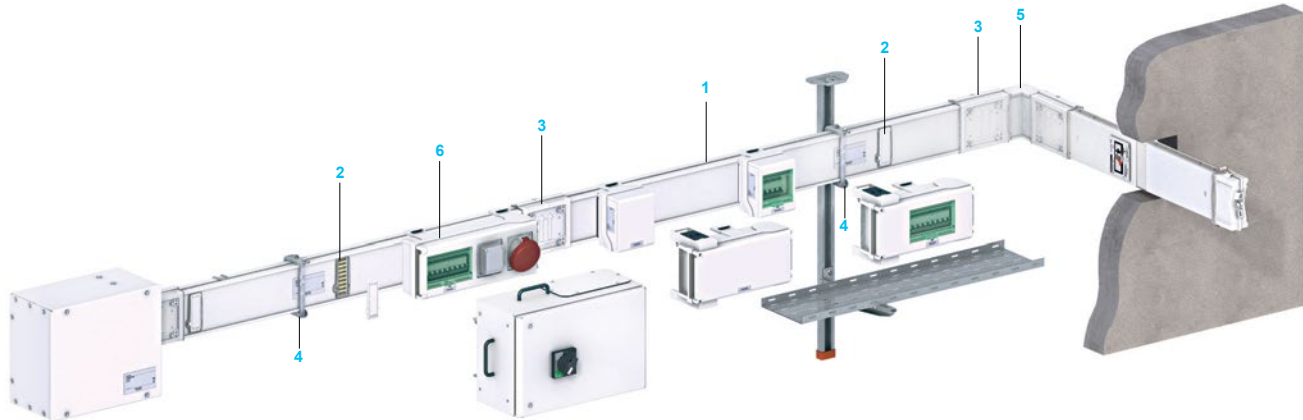

Complies with standards IEC 61439-6.

Complies with sprinkler tests, guaranteeing operation under vertically and horizontally sprayed water for 50 minutes.

Degree of protection: IP55.

Number of live conductors: 4.

Rated insulation voltage: 690 V.

Rated current (I_{nc}): 100 A, 160 A, 250 A, 400 A, 500 A, 630 A, 800 A and 1000 A.

The cross-sectional area of the protective conductor is at least 50 % that of the phases.

Fire resistance:

- fire barriers as per standard ISO 834 (DIN 4102-part 9) for passages through partitions.
- resistant to flame propagation in compliance with standard IEC 60332 - part 3.
- materials resistant to abnormal heat (glow-wire test as per IEC 60695-2).

All plastic components are halogen free.

- The enclosure (1), made of sheet steel, galvanised and pre-lacquered RAL 9001 white.
- The four aluminium conductors are mounted on fibreglass reinforced polyester insulators. All electrical contacts are made of silver-plated copper.
- The straight lengths have a tap-off unit (2) every metre on both sides. The tap-off outlets are equipped with automatic shutters that avoid accidental contact with live parts. The protective conductor is electrically connected to the enclosure at each jointing unit.
- Electrical contact between two components is ensured by flexible contacts designed to adapt to the difference in expansion between the conductors and the enclosure. It is possible to check visually that the electrical contact is effective. The mechanical junction between two components is ensured by four captive screws. The jointing unit (3) is maintenance free.
- The rigidity of the straight lengths is sufficient that fixing points (4) are required only every three metres (excepting special conditions).
- Special components (5) are available to change direction or avoid obstacles.
- The tap-off units (6) have the following characteristics:
 - connection and disconnection are possible only with the cover open
 - the contact of the protective conductor ensures automatic opening of the shutters and feeds the tap-off unit
 - there is no access to live parts when the cover of the tap-off unit is open (no finger access, IPxxD)
 - when the tap-off unit is plugged in, the earthing contact connects first, followed by the phases
 - it is not possible to close the cover before the tap-off unit is mechanically locked on the trunking, tap-off units can be equipped with fuses, modular devices or moulded case circuit breakers.

Characteristics and recommendations

Technical specifications

Rising mains

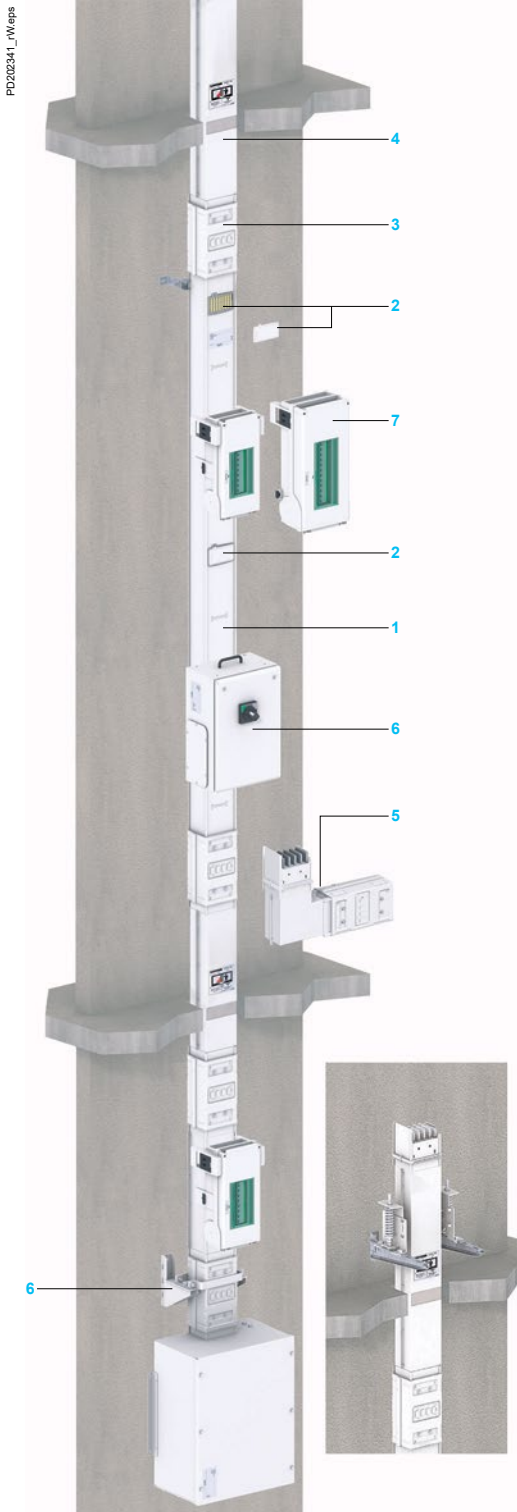

Complies with standards IEC 61439-6.

Complies with sprinkler tests, providing operation under vertically and horizontally sprayed water for 50 minutes.

Degree of protection: IP55.

Number of live conductors: 4.

Rated insulation voltage: 690 V.

Rated current (I_{nc}): 100 A, 250 A, 400 A, 500 A, 630 A, 800 A and 1000 A.

The cross-sectional area of the protective conductor is at least 50 % that of the phases.

Fire resistance:

- fire barriers as per standard ISO 834 (DIN 4102-part 9) for passages through partitions (slabs for example).
- resistant to flame propagation in compliance with standard IEC 60332 - part 3.
- materials resistant to abnormal heat (glow-wire test as per IEC 60695-2).

All plastic components are halogen free.

- The enclosure (1), made of sheet steel, galvanised and pre-lacquered RAL 9001 white.
- The four aluminium conductors are mounted on fibreglass reinforced polyester insulators. All electrical contacts are made of silver-plated copper.
- The straight lengths have a tap-off unit (2) every 0.5 metre on one side. There are four tap-off units per floor for floor heights between 3.5 and 4.8 metres, or three tap-off units per floor for floor heights less than 3.5 metres. The tap-off outlets are equipped with automatic shutters that avoid accidental contact with live parts. The protective conductor is electrically connected to the enclosure at each jointing unit.

■ Electrical contact between two components is provided by flexible contacts designed to adapt to the difference in expansion between the conductors and the enclosure.

It is possible to check visually that the electrical contact is effective.

The mechanical junction between two components is fixed by four captive screws.

The jointing unit (3) is maintenance free.

- A fire barrier (4) can be installed when the riser passes through a slab to avoid any risk of fire propagation from one floor to another.

Two-hour fire resistance (A120) is provided in compliance with standard ISO834 (DIN 41-2-part 9).

- Special components (5) are available to change direction or avoid obstacles.
- The riser can be maintained by a special bottom support (6) or a spring -based fixing device on each floor of the building (depending on the height of the building).
- The tap-off units (7) have the following characteristics:
 - connection and disconnection are possible only with the cover open
 - the contact of the protective conductor helps automatic opening of the shutters and feeds the tap-off unit
 - there is no access to live parts when the cover of the tap-off unit is open (no finger access, IPxxD)
 - when the tap-off unit is plugged in, the earthing contact connects first, followed by the phases
 - it is not possible to close the cover before the tap-off unit is mechanically locked on the trunking, tap-off units can be equipped with modular devices or moulded case circuit breakers.

Characteristics and recommendations

Electrical characteristics

From 100 to 1000 A - IP55 - $U_e = 230 \dots 690$ V

Run component characteristics

Rating of trunking (A)				KS	100	160	250	400	500	630	800	1000			
General characteristics															
Compliance with standards					IEC/EN 61439-6										
Degree of protection				IP	55	55	55	55	55	55	55	55			
Mechanical impacts				IK	08	08	08	08	08	08	08	08			
Rated current at an ambient temperature of 35 °C				I_{nc}	A	100	160	250	400	500	630	800	1000		
Rated insulation voltage				U_i	V	690	690	690	690	690	690	690			
Rated operational voltage				U_e	V	690	690	690	690	690	690	690			
Rated impulse voltage				U_{imp}	kV	8	8	8	8	8	8	8			
Rated frequency				f	Hz	50/60	50/60	50/60	50/60	50/60	50/60	50/60			
Conductor characteristics															
Phase conductors															
Mean resistance at an ambient temperature of 20 °C				R_{20}	mΩ/m	1.19	0.55	0.28	0.15	0.11	0.09	0.06	0.04		
Mean resistance at I_{nc} and 35 °C				R_1	mΩ/m	1.59	0.77	0.39	0.21	0.15	0.13	0.09	0.06		
Mean reactance at I_{nc} , 35 °C and 50 Hz				X_1	mΩ/m	0.15	0.15	0.16	0.14	0.07	0.07	0.06	0.06		
Mean impedance at I_{nc} , 35 °C and 50 Hz				Z_1	mΩ/m	1.6	0.79	0.42	0.25	0.16	0.15	0.11	0.09		
Protective conductor (PE)															
Mean resistance at an ambient temperature of 20 °C					mΩ/m	0.42	0.42	0.35	0.19	0.07	0.07	0.07	0.06		
Copper cross-section					mm²	4	4	22	50	222	222	222	252		
Fault loop characteristics															
Symmetrical components method	Ph/N at 20 °C	Mean resistance	$R_{0\ ph/N}$	mΩ/m	4.85	2.32	1.28	0.74	0.5	0.45	0.32	0.23			
		Mean reactance	$X_{0\ ph/N}$	mΩ/m	0.95	0.95	0.86	0.67	0.36	0.35	0.31	0.27			
		Mean impedance	$Z_{0\ ph/N}$	mΩ/m	4.94	2.5	1.54	1	0.62	0.57	0.45	0.36			
	Ph/PE at 20 °C	Mean resistance	$R_{0\ ph/PE}$	mΩ/m	2.75	2.01	1.34	0.88	0.4	0.51	0.35	0.32			
		Mean reactance	$X_{0\ ph/PE}$	mΩ/m	1.11	0.93	0.7	0.67	0.48	0.55	0.43	0.4			
		Mean impedance	$Z_{0\ ph/PE}$	mΩ/m	2.96	2.22	1.51	1.11	0.63	0.75	0.56	0.51			
Impedance method	At 20 °C	Mean resistance	Ph/Ph	$R_{b0\ ph/ph}$	mΩ/m	2.4	1.15	0.65	0.41	0.25	0.23	0.18	0.15		
			Ph/N	$R_{b0\ ph/N}$	mΩ/m	2.44	1.21	0.74	0.51	0.3	0.28	0.23	0.2		
			Ph/PE	$R_{b0\ ph/PE}$	mΩ/m	1.87	1.3	0.78	0.55	0.31	0.3	0.28	0.26		
	For I_{nc} at 35 °C	Mean resistance	Ph/Ph	$R_{b1\ ph/ph}$	mΩ/m	3.19	1.55	0.78	0.57	0.35	0.32	0.25	0.21		
			Ph/N	$R_{b1\ ph/N}$	mΩ/m	3.21	1.57	0.82	0.7	0.41	0.39	0.32	0.28		
			Ph/PE	$R_{b1\ ph/PE}$	mΩ/m	2.38	1.46	0.91	0.76	0.43	0.41	0.39	0.37		
	For I_{nc} at 35 °C and 50 Hz	Mean reactance	Ph/Ph	$X_{b\ ph/ph}$	mΩ/m	0.31	0.31	0.32	0.28	0.14	0.14	0.13	0.12		
			Ph/N	$X_{b\ ph/N}$	mΩ/m	0.45	0.45	0.45	0.39	0.2	0.2	0.18	0.17		
			Ph/PE	$X_{b\ ph/PE}$	mΩ/m	0.58	0.42	0.42	0.39	0.24	0.24	0.23	0.22		
	Other characteristics														
	Short-circuit withstand capacity														
	Rated peak withstand current				I_{pk}	kA	15.7	22	28	49.2	55	67.5	78.7	78.7	
Maximum thermal limit I^2t (t = 1 s)					10⁶ A²s	6.8	20.2	100	354	733	1225	1758	1758		
Rated short-time withstand current (t = 1 s)				I_{cw}	kA	2.6	4.45	10	18.8	26.2	32.1	37.4	37.4		
Voltage drop				Composite voltage drop (hot state) expressed in V/100 m/A (50 Hz) with the load uniformly distributed over the run. If the load is concentrated at one end of the run, the voltage drop is twice the value indicated in the table.											
For a power factor of						1	V/100 m/A	0.138	0.067	0.034	0.018	0.013	0.011	0.008	0.005
						0.9	V/100 m/A	0.130	0.066	0.036	0.022	0.014	0.013	0.009	0.007
						0.8	V/100 m/A	0.118	0.061	0.035	0.022	0.014	0.013	0.009	0.007
						0.7	V/100 m/A	0.106	0.056	0.034	0.021	0.013	0.012	0.009	0.008
				This calculation table applies to the three-phase system. To obtain the single-phase voltage drop, the three-phase voltage drop shown above is divided by 1.732.											
Radiated magnetic field															
Radiated magnetic field strength 1 metre from the trunking				B	μT	0.22	0.41	0.69	1.00	0.66	0.89	1.12	1.27		
Product selection when harmonics are present (for details, see the "Special Applications" section)															
Operational current as a function of 3 rd harmonic content				THD ≤ 15 %		100	160	250	400	500	630	800	1000		
				15 % < THD ≤ 33 %		80	125	200	315	400	500	630	800		
				THD > 33 %		63	100	160	250	315	400	500	630		
Permissible current as a function of ambient temperature															
Ambient temperature				°C		< 35	35	40	45	50	55				
Coefficient K1				%		n/a	1	0.97	0.94	0.91	0.87				

Characteristics and recommendations

Electrical characteristics

From 100 to 1000 A - IP55 - U_e = 230...690 V

Tap-off unit characteristics

General characteristics			
Degree of protection	IP		55
Mechanical impacts	IK		08
Rated insulation voltage ⁽¹⁾	U _i	V	400, 500 depending on protective device
Rated operational voltage ⁽¹⁾	U _e	V	400, 500 depending on protective device
Rated impulse voltage	U _{imp}	kV	6.8
Rated frequency	f	Hz	50/60

(1) For 690 V, please see your sales office.

Radiated electromagnetic fields

According to the WHO (World Health Organisation), exposure to radiated electromagnetic fields above 0.2 micro Tesla can be critical causing a risk of cancer over the long term. Some countries have standardised the limit:

Sweden = 0.2 μT, at a distance of 1 metre.

All electrical conductors generate a magnetic field, the strength of which is proportional to the distance between them. The Canalis busbar trunking concept (metal casing and conductors near together) helps to considerably reduce radiated electromagnetic fields.

In specific cases where particularly low values are required (computer rooms, hospitals, some offices), it is important to keep in mind the following:

- the induction generated around 3-phase distribution. This is proportional to the current and the distance between the conductors, and inversely proportional to the square of the distance with respect to the busbar trunking and the screening effect of the case
- the induction generated around busbar trunking. This is less than the induction generated around an equivalent cable distribution
- Canalis' steel casing. This attenuates the induction more than an equivalent aluminium casing of the same thickness (screening effect)
- the induction generated around busbar trunking with sandwiched bars. This is particularly low because of the short distance between the bars and the additional attenuation provided by the steel casing.

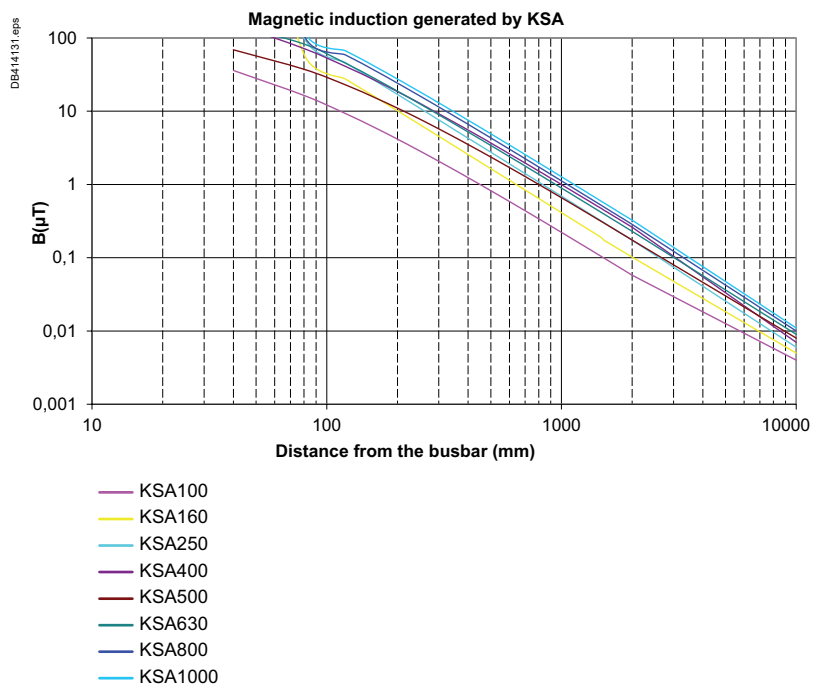

Characteristics and recommendations

Recommendations for special applications

How Canalis compensate for thermal expansion

Foreword

Prefabricated electrical trunking components expand and contract due to:

- changes in ambient temperature (e.g. summer and winter)
- current flowing in the conductors (e.g. 0 to In)

For example, consider a 30 metre long 800 A Canalis KS line equipped with ten 160 A tap-off units and installed under the roof of a building where the ambient temperature varies by more than 30 °C between summer and winter:

- just the change in the ambient temperature results in an expansion of 20 mm for the conductors and the 10 mm for the casing
- at a constant ambient temperature, the temperature rise in the conductors every morning when the installation is started (increase in current from 0 to In = 800 A) results in an expansion of 55 mm for the conductors and 7 mm for the casing.

The lengths of the sheet steel (1) and the aluminium conductors (2) therefore vary as a function of the changes in temperature and their specific thermal expansion coefficients.

PD202309_c2W.eps



For this reason, Canalis components are designed to avoid impact on their installation or operation due to this phenomenon.

How Canalis trunking components effectively compensate for the effects of conductor thermal expansion

Inside a trunking section, the conductors are fixed (1) at a single point in the casing and, due to the change in temperature, expand (→) on either side of that point. The zones affected by expansion and considered important from the electrical standpoint are the jointing system (2) and tap-off outlets (3).

DD202281.eps

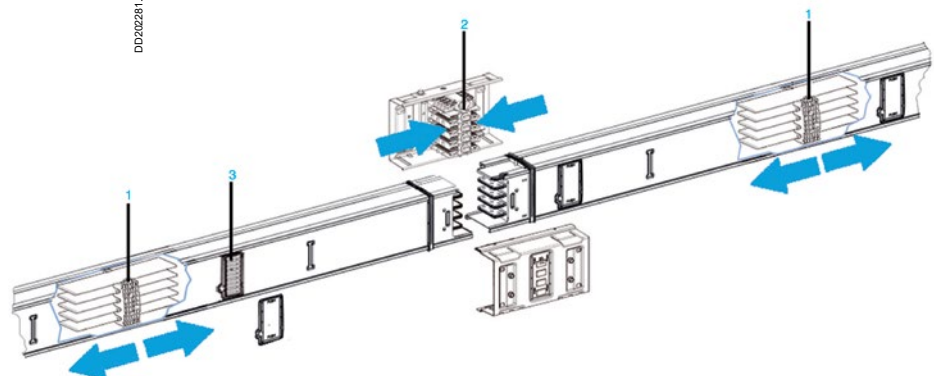

Characteristics and recommendations

Recommendations for special applications

How Canalis compensate for thermal expansion

How Canalis trunking components effectively compensate for the effects of conductor thermal expansion

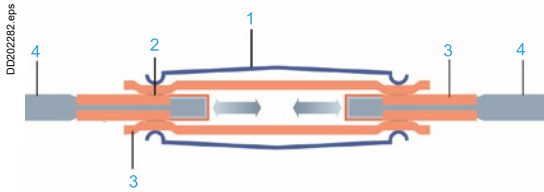

■ The Canalis jointing system mechanically and electrically connects components (e.g. two straight lengths), but allows for the expansion and contraction of the conductors (4).

The system is made up of springs (1) and an area of sliding contacts (2) that allow conductor movement (→) while maintaining outstanding electrical contact. Contact quality is maintained by two parts made of silver-plated copper (3). Sufficient pressure between the two parts for good contact is maintained by the springs. This system is used at each end of the straight lengths, every three metres.

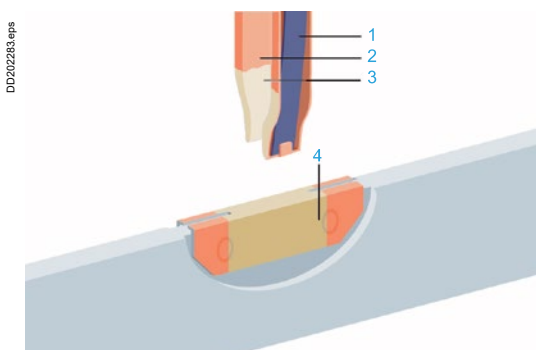

■ At the tap-offs, conductor expansion is compensated for by a contact zone (4) made of silver-plated copper on which the clamps of the tap-off unit can slide.

- 1 Spring of clamps.
- 2 Copper area.
- 3 Silver plated copper.

Conclusion:

at both the jointing system and the tap-off outlets, sliding contacts can handle the expansion of the conductors.

These maintenance-free silver-plated contacts are assured for life.

Only the expansion of the sheet steel must be taken into account for Canalis installation, however the problem is minor because both trials and calculations show that expansion is only approximately 1 mm for every three-metre length under extreme operating conditions.

Characteristics and recommendations

Recommendations for special applications

How Canalis compensate for thermal expansion

Few precautionary measures used to compensate for the effects of thermal expansion in the casing, depending on how the line is installed.

Horizontal line

For a trunking line made up exclusively of straight lengths, as noted above, the effects of thermal expansion are not significant (only 1 mm for 3 m). To avoid impact of problems, Canalis trunking supports allow movement of the casing, i.e. no fixed points.

For a fixed point caused by a blocked elbow, for example, the casings compensate their expansion by slight lateral movement (0.7 mm maximum) on either side of the longitudinal axis. This movement has no impact on the contact quality of the jointing system or on the IP.

Conclusion:

The only precautionary measure is to restrict distortion by avoiding having a number of fixed points on a single line.

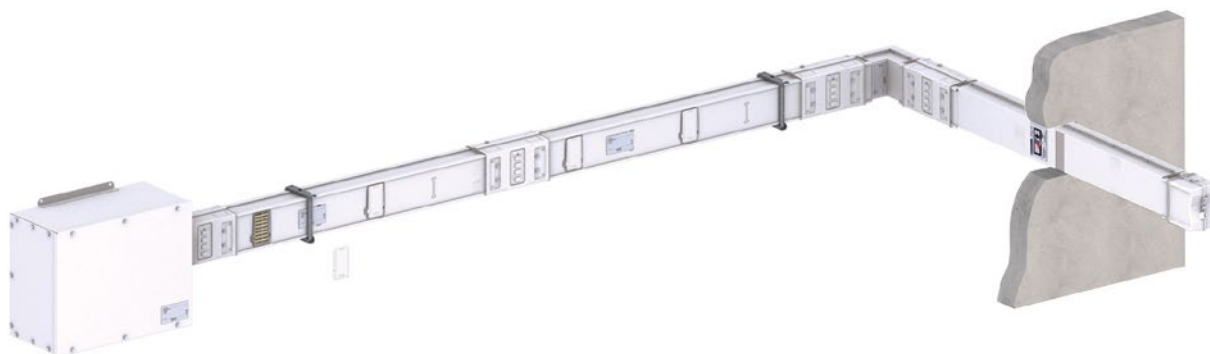

PD2023_10_AW5.eps

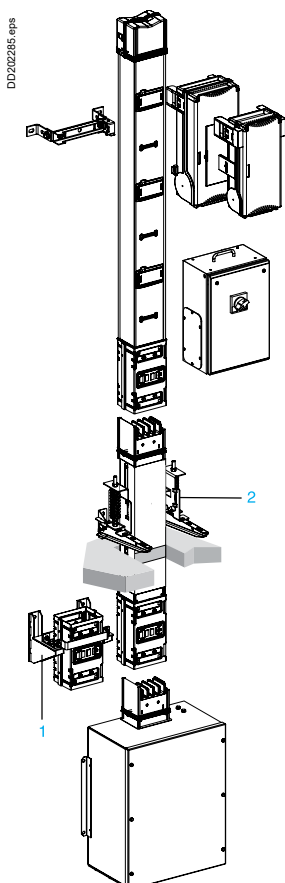

DD20285.eps

Vertical line (rising mains)

The effects of thermal expansion depend on the different installation methods.

Rising mains with just one bottom support (1)

With a bottom support attached to the wall, the riser expands upwards. At each floor, the sheet steel slides naturally through the floor.

The only precautionary measure is to avoid creating any other fixed points.

Rising mains with spring-based fixing devices (2)

For rising mains with spring-based fixing devices only, the riser expands both upwards and downwards. At each floor, the casing slides naturally through the fire barriers.

Rising mains with more than one bottom support (1)

More than one bottom support should not be used on a single riser to avoid creating a number of fixed points that block thermal expansion of the casing, in which case a component in the line may break.

If more than one bottom support is necessary, it is advised to break the riser into a number of sections, interconnected by cables and feed boxes, to allow thermal expansion (see section "above on Rising mains with just one bottom support").

Installation of rising mains does not require any particular precautionary measures. All the above solutions have been simulated by calculations and tested in a laboratory. Schneider Electric assures that they will maintain the protection and reliability of your installation.

Characteristics and recommendations

Coordination

Trunking protection: Overload protection

The busbar trunking rating can be optimised when the trunking is protected by circuit breakers rather than fuses.

Selection of busbar trunking with respect to protective device ratings

To take into account busbar trunking thermal overload protection, the various protection switchgear technologies and the currents under overload conditions must be considered.

The sizing characteristics for the choice of busbar trunking and overload protection are:

- In trunking = load current $\times f_1 \times k_2$
- f_1 : temperature coefficient
- k_2 : derating factor linked to the type of switchgear:
 - fuse: $k_2 = 1.1$
 - circuit breaker: $k_2 = 1$.

Example:

For a load current = 400 A with an ambient temperature of 35 °C:

> Fuse protection:

In trunking = load current $\times f_1 \times k_2 = 400 \times 1 \times 1.1 = 440$ A
 The recommended trunking is KSA500 (In trunking = 500 A).

> Circuit breaker protection:

In trunking = load current $\times f_1 \times k_2 = 400 \times 1 \times 1 = 400$ A
 The recommended trunking is KSA400 (In trunking = 400 A).

Due to their design, circuit breaker thermal settings are more precise.

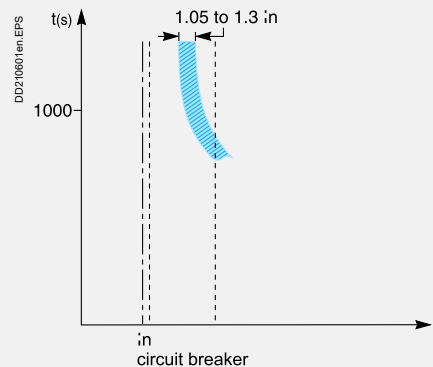
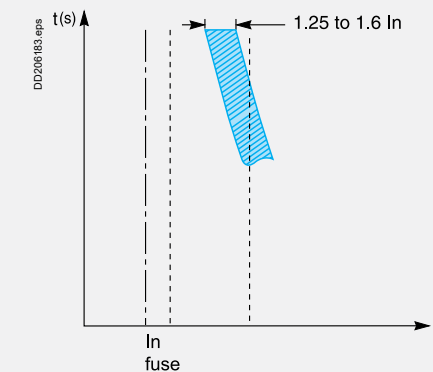

Explanations

Calibration of thermal asymptotes:

- > distribution fuses are calibrated to trip for overloads of between **1.25 and 1.6** times their rated current
- > circuit breakers are calibrated to trip for overloads of between **1.05 and 1.3** (1.2 for circuit breakers with electronic protection) times their current setting.

Characteristics and recommendations

Coordination

Trunking protection: Overload protection

Thermal-setting precision

- The fuse is assigned a fixed rating. A change in the current to be protected requires fuse replacement. **The difference between 2 fuse ratings is approximately 25 %.**

Standard ratings are given according to the series of characteristic numbers of the "Renard" series.

For example: 40 - 50 - 63 - 80 - 100 - 125 - 160 - 200 - etc.

- **the circuit breaker offers a setting precision of:**

- **5 %** for circuit breakers equipped with conventional **thermal-magnetic** trip units
- **3 %** for circuit breakers equipped with **electronic** trip units.

For example, a circuit breaker with a nominal rating of 100 A can easily be set to values of $I_r = 100$ A, 95 A, 90 A, 85 A, 80 A.

Example:

A circuit breaker with a nominal rating of 100 A set to 90 A will be used to protect KSA100 busbar trunking (I_n trunking = 100 A) which is used for an ambient temperature of 50 °C.

Extensive setting range of circuit breakers equipped with electronic trip units

Circuit breakers equipped with electronic trip units offer an extended range of settings:

- thermal protection I_r adjustable from 0.4 I_n to I_n
- short-circuit protection from 2 I_r to 10 I_r .

Example:

A 250 A circuit breaker (NSX250N equipped with an STR22SE) can easily be set up for:

- > thermal protection from 100 to 250 A
- > short-circuit protection from 200 to 2500 A.

Advantages:

- This provides a high degree of flexibility with respect to:
 - modifications (flexibility), extensions (upgradeability): protective devices can be easily adapted to the application requiring protection and to the system earthing arrangement used (protection of life and property)
 - maintenance: use of this type of device considerably reduces maintenance component stocks.

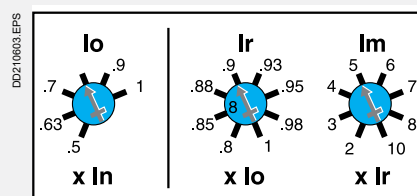

Example of setting possibilities

Characteristics and recommendations

Coordination

Trunking protection: Short-circuit protection

Trunking characteristics

Busbar Trunking Systems (BTS) must meet all rules stipulated in standards IEC 60439.1 and 60439.6.

■ With respect to short-circuits, BTS sizing is determined by the following characteristics:

□ **rated peak withstand current I_{pk} (kA):**

this characteristic expresses the instantaneous electrodynamic withstand limits of the busbar trunking. The peak current value is often the most restrictive instantaneous characteristic for the protective device

□ **maximum rms short-time withstand current I_{cw} (kArms/...s):**

this characteristic expresses the permissible temperature-rise limit of conductors over a given period of time (0.1 to 1 s)

□ **thermal stress in A^2s :**

this characteristic expresses the instantaneous thermal stress withstand of the BTS. Normally, if the short-circuit generates fault conditions that are compatible with the first two characteristics, this constraint is "automatically satisfied"

Circuit breaker characteristics

A circuit breaker must meet the requirements of product construction standards (IEC 60947-2, etc.) and installation standards (IEC 60364 or applicable country standards), i.e. its breaking capacity I_{cu} ⁽¹⁾ must be greater than short-circuit current I_{sc} at the point where it is installed.

(1) Installation standard IEC 60364 and the construction standards specify that the breaking capacity of a circuit breaker is:

- the ultimate breaking capacity, I_{cu} , if it is not coordinated with an upstream protective device,
- the breaking capacity enhanced by cascading, if there is coordination with the upstream protective device.

Characteristics of the circuit breaker /trunking combination

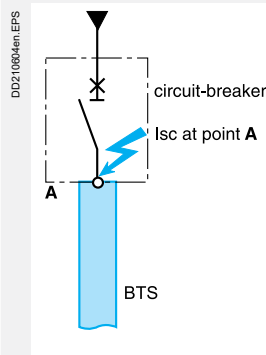

When the busbar trunking is directly protected, selection of the protective device must take into account the following requirements:

- circuit breaker $I_{cu} \geq$ prospective I_{sc} at **point A**
- BTS $I_{peak} \geq$ limited or asymmetrical prospective I_{sc} at **point A**
- BTS thermal withstand at $I_{cw} \geq$ thermal stress

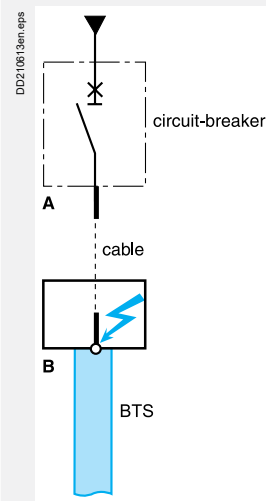

passing through the BTS.

When the busbar trunking is protected downstream of a cable, selection of the protective device must take into account the following requirements:

- circuit breaker $I_{cu} \geq$ prospective I_{sc} at **point A**
- BTS $I_{peak} \geq$ limited or asymmetrical prospective I_{sc} at **point B**
- BTS thermal withstand at $I_{cw} \geq$ thermal stress passing through the BTS.

Characteristics and recommendations

Coordination

Circuit breaker/trunking coordination

Non-limiting or time-delayed circuit breakers

Either non-limiting (instantaneous or time-delayed) or time-delayed limiting circuit breakers can be used. They are mainly air-type power (= 800 A) circuit breakers.

This type of circuit breaker is used to implement time discrimination and is often combined with KT type trunking.

- The busbar trunking must be capable of withstanding the peak fault current to which it may be subjected as well as the thermal stress during any time delay:
 - the permissible peak current, I_{peak} , of the BTS must be greater than the peak value of the prospective asymmetrical short-circuit current at point A.
- The value of the asymmetrical short-circuit current is obtained from the value of the symmetrical short-circuit current, I_{sc} , multiplied by a standardised asymmetry factor (k).
- The value of the first short-circuit asymmetry peak in the transient state is taken into account.

Standardised table for asymmetrical short-circuit calculations

I_{sc}: prospective symmetrical short-circuit kA (rms value)	Asymmetry factor k
$4.5 \leq I \leq 6$	1.5
$6 < I \leq 10$	1.7
$10 < I \leq 20$	2.0
$20 < I \leq 50$	2.1
$50 < I$	2.2

For example, for a circuit with a prospective short-circuit current of 50 kA rms, the first peak reaches 105 kA ($50 \text{ kA} \times 2.1$). See the figure below.

- the short-time withstand current I_{cw} of the BTS must be greater than the current I_{sc} flowing through the installation for the duration of the short-circuit, (duration T = total breaking time, including the time delay if applicable).

If one of these criteria is not satisfied, the rating of the busbar trunking to be used must be increased.

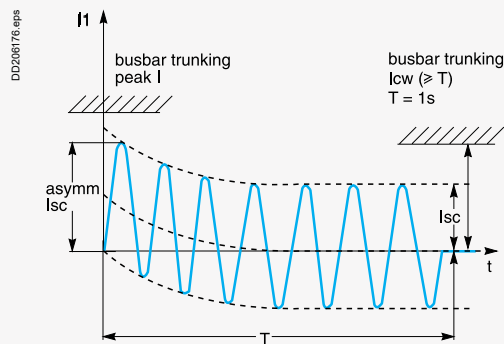

Current value of the 1st. peak as a function of rms I_{sc} .

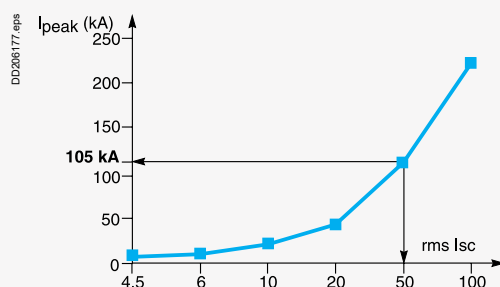

Transient and steady states of a short-time short-circuit.

Limiting circuit breakers

This mainly concerns protection of BTSs by moulded-case circuit breakers (≤ 1600 A).

This type of circuit breaker is used for energy discrimination and is therefore often combined with Canalis KN and KS trunking.

- In this case, the BTS must withstand the peak current limited by the protective device and the corresponding thermal stress.
- The current limited (I_{peak}) by the circuit breaker must be less than the peak current permitted in the BTS.
- The thermal stress limited by the circuit breaker must be less than the thermal stress permitted in the BTS.

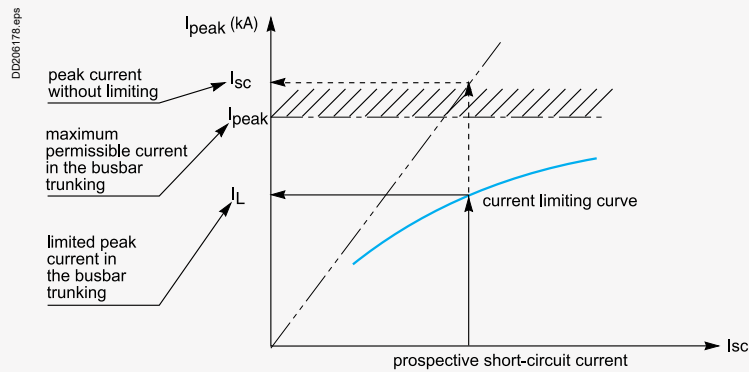

Checking the BTS withstand capacity in terms of peak current.

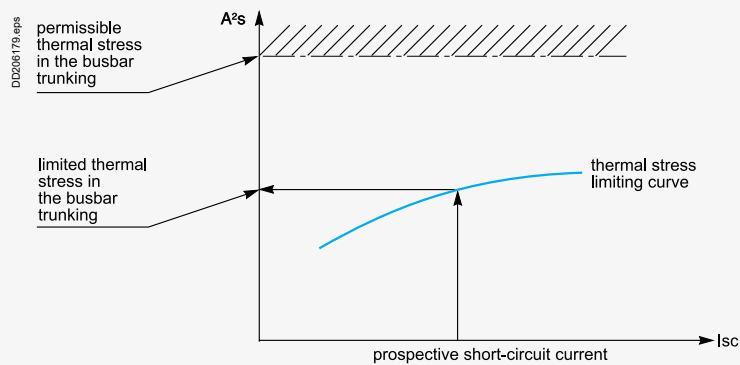

Checking the BTS withstand capacity in terms of thermal stress

Characteristics and recommendations

Coordination

BTS protection by Compact NSX limiting circuit breakers

Limiting capacity



Busbar trunking ratings can be optimised when circuit breakers rather than fuses are used for protection.

The circuit breakers in the Compact NSX and Compact NSXm ranges are limiting circuit breakers with a high current-limiting capacity.

A circuit breaker's limiting capacity is its ability to let only a limited current I_L , lower than the prospective asymmetrical peak short-circuit current I_{sc} through in the event of a short-circuit.

The effect is a considerable reduction in electrodynamic and thermal stresses in the installation.

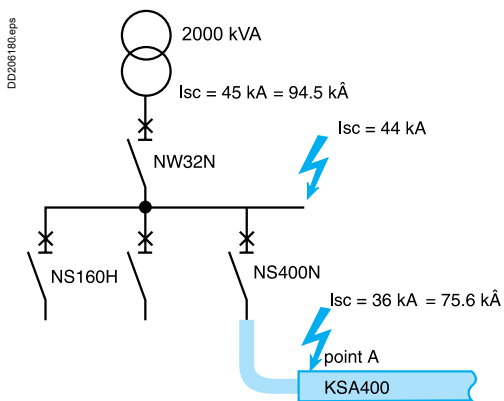

Example of a mid-sized installation (> 1000 kVA)

The diagram opposite shows the protection provided by an NSX400N limiting circuit breaker for KSA400 trunking.

- Without taking into account the circuit breaker's limiting capacity:
 - the prospective I_{sc} at point A would be 75.6 kA
 - KSA800 trunking would be required ($I_{peak} = 78.7 \text{ kA} > 75.6 \text{ kA}$ at point A).
- Taking into account the limiting capacity of the Compact NSX400N:
 - the value of I_{peak} limited by the circuit breaker is: $30 \text{ kA} < 49.2 \text{ kA}$ of the KSA400 trunking
 - the value of the limited thermal stress is: $1.6 \times 10^6 < 354 \times 10^6$ of the KSA400 trunking.

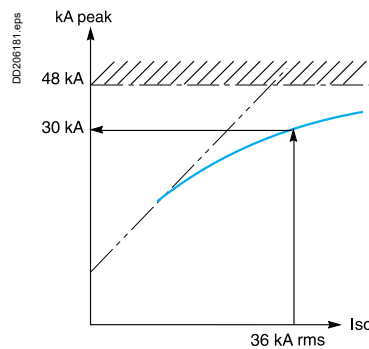

Current limiting.

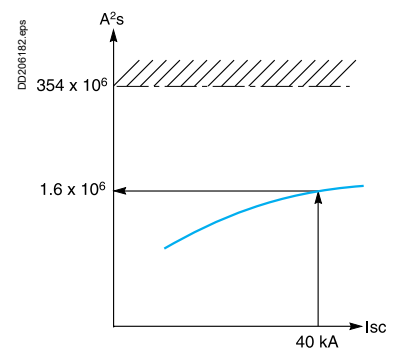

Energy limiting.

Thanks to the high limiting capacity of Compact NSX400N circuit breakers, KSA400 busbar trunking can be used for prospective I_{sc} values up to 50 kA (105 kA) at point A.

Characteristics and recommendations

Coordination

Selection guide

The selection guides below can be used to determine the circuit breaker required to fully protect the trunking depending on the prospective short-circuit current of the installation.

Example: in an installation with a prospective I_{sc} of 15 kA, the circuit breaker required to protect 25 A KBB trunking is a C60H (the rating depends on the rated current of the circuit).

In bold, the most appropriate device to the rating of the busbar trunking.

Selection guide for U_e : 380-415 V AC

Type of Canalis busbar trunking KSA100							
Isc max. in kA rms		25 kA	36 kA	50 kA			
Type of circuit breaker	NG125	NG125N100	NG125H80	NG125L80			
	Compact NSXm	NSXm B/F/N/H 100	NSXm F/N/H 100	-			
	Compact NSX	NSX100B/F/N/H/S/L	-	-			

Type of Canalis busbar trunking KSA160						
Isc max. in kA rms		25 kA	36 kA	50 kA	70 kA	90 kA
Type of circuit breaker	Compact NSXm	NSXm B/F/N/H 160	NSXm F/N/H 160	NSXm N/H 160	NSXm N/H 160	-
	Compact NSX	NSX100B/F/N/H/S/L	NSX100F/N/H/S/L	NSX100N/H/S/L	NSX100H/S/L	NSX100S/L
		NSX160B/F/N/H/S/L	NSX160F/N/H/S/L	NSX160N/H/S/L	NSX160H/S/L	-
		NSX250B/F/N/H/S/L	NSX250F/N/H/S/L	NSX250N/H/S/L	-	-

Type of Canalis busbar trunking KSA250							
Isc max. in kA rms		25 kA	36 kA	50 kA	70 kA	100 kA	150 kA
Type of circuit breaker	Compact NSX	NSX160B/F/N/H/S/L	NSX160F/N/H/S/L	NSX160N/H/S/L	NSX160H/S/L	NSX160S/L	NSX160L
		NSX250B/F/N/H/S/L	NSX250F/N/H/S/L	NSX250N/H/S/L	NSX250H/S/L	NSX250S/L	NSX250L
		NSX400F/N/H/S/L	NSX400F/N/H/S/L	NSX400N/H/S/L	-	-	-

Type of Canalis busbar trunking KSA400							
Isc max. in kA rms		25 kA	36 kA	50 kA	70 kA	100 kA	150 kA
Type of circuit breaker	Compact NSX	NSX250B/F/N/H/S/L	NSX250F/N/H/S/L	NSX250N/H/S/L	NSX250H/S/L	NSX250S/L	NSX250L
		NSX400F/N/H/S/L	NSX400F/N/H/S/L	NSX400N/H/S/L	NSX400H/S/L	NSX400S/L	NSX400L
		NSX630F/N/H/S/L	NSX630F/N/H/S/L	NSX630N/H/S/L	NSX630H/S/L	NSX630S/L	NSX630L
	Compact NS	NS630b N/H/L/LB	NS630b L / LB	NS630b L / LB	NS630b LB	-	-

Type of Canalis busbar trunking KSA500							
Isc max. in kA rms		25 kA	36 kA	50 kA	70 kA	100 kA	150 kA
Type of circuit breaker	Compact NSX	NSX400F/N/H/S/L	NSX400F/N/H/S/L	NSX400N/H/S/L	NSX400H/S/L	NSX400S/L	NSX400L
		NSX630F/N/H/S/L	NSX630F/N/H/S/L	NSX630N/H/S/L	NSX630H/S/L	NSX630S/L	NSX630L
	Compact NS	NS630b N/H/L/LB	NS630b N/H/L/LB	NS630b L / LB	NS630b LB	NS630b LB	-

Type of Canalis busbar trunking KSA630							
Isc max. in kA rms		≤ 32 kA	36 kA	50 kA	70 kA	100 kA	150 kA
Type of circuit breaker	Compact NSX	NSX400F/N/H/S/L	NSX400F/N/H/S/L	NSX400N/H/S/L	NSX400H/S/L	NSX400S/L	NSX400L
		NSX630F/N/H/S/L	NSX630F/N/H/S/L	NSX630N/H/S/L	NSX630H	NSX630S/L	NSX630L
	Compact NS	NS630b N/H/L/LB	NS630b L/LB	NS630b L/LB	NS630b L/LB	NS630b L/LB	NS630b LB
		NS800N/H/L/LB	NS800L/LB	NS800L/LB	NS800L/LB	NS800L/LB	NS800LB
	Masterpact MTZ1	MTZ1 06 H1/H2/H3/L1	MTZ1 06 L1	MTZ1 06 L1	MTZ1 06 L1	MTZ1 06 L1	-
		MTZ1 08 H1/H2/H3/L1	MTZ1 08 L1	MTZ1 08 L1	MTZ1 08 L1	MTZ1 08 L1	-

Type of Canalis busbar trunking KSA800							
Isc max. in kA rms		25 kA	36 kA	50 kA	70 kA	100 kA	150 kA
Type of circuit breaker	Compact NSX	NSX630F/N/H/S/L	NSX630F/N/H/S/L	NSX630N/H/S/L	NSX630H/S/L	NSX630S/L	NSX630L
	Compact NS	NS630b N/H/L/LB	NS630b N/H/L/LB	NS630b L/LB	NS630b L/LB	NS630b L/LB	NS630b L/LB
		NS800N/H/L/LB	NS800N/H/L/LB	NS800L/LB	NS800L/LB	NS800L/LB	NS800L/LB
		NS1000N/H/L	NS1000N/H/L	NS1000L	NS1000L	NS1000L	NS1000L
	Masterpact MTZ1	MTZ1 06 H1/H2/H3/L1	MTZ1 06 H1/H2/H3/L1	MTZ1 06 L1	MTZ1 06 L1	MTZ1 06 L1	MTZ1 06 L1
		MTZ1 08 H1/H2/H3/L1	MTZ1 08 H1/H2/H3/L1	MTZ1 08 L1	MTZ1 08 L1	MTZ1 08 L1	MTZ1 08 L1
		MTZ1 10 H1/H2/H3/L1	MTZ1 10 H1/H2/H3/L1	MTZ1 10 L1	MTZ1 10 L1	MTZ1 10 L1	MTZ1 10 L1

Type of Canalis busbar trunking KSA1000							
Isc max. in kA rms		25 kA	36 kA	50 kA	70 kA	100 kA	150 kA
Type of circuit breaker	Compact NS	NS800N/H/L/LB	NS800N/H/L/LB	NS800L/LB	NS800L/LB	NS800L/LB	NS800L/LB
		NS1000N/H/L	NS1000N/H/L	NS1000L	NS1000L	NS1000L	NS1000L
		NS1250N/H	NS1250N/H	-	-	-	-
	Masterpact MTZ1	MTZ1 08 H1/H2/H3/L1	MTZ1 08 H1/H2/H3/L1	MTZ1 08 L1	MTZ1 08 L1	MTZ1 08 L1	MTZ1 08 L1
		MTZ1 10 H1/H2/H3/L1	MTZ1 10 H1/H2/H3/L1	MTZ1 10 L1	MTZ1 10 L1	MTZ1 10 L1	MTZ1 10 L1
		MTZ1 12 H1/H2/H3	MTZ1 12 H1/H2/H3	-	-	-	-

Characteristics and recommendations

Coordination

Selection guide







Selection guide for Ue: 660-690 V AC

Type of Canalis busbar trunking KSA100								
Isc max. in kA rms		10 kA	15 kA	20 kA	25 kA	45 kA	75 kA	100 kA
Type of circuit breaker	Compact NSX	NSX100N/H/S/L NSX160N/H/S/L NSX250N/H/S/L	NSX100S/L NSX160S/L NSX250S/L	NSX100L	-	-	-	-
Type of Canalis busbar trunking KSA160								
Isc max. in kA rms		10 kA	15 kA	20 kA	25 kA	45 kA	75 kA	100 kA
Type of circuit breaker	Compact NSX	NSX100N/H/S/L NSX160N/H/S/L NSX250N/H/S/L	NSX100S/L NSX160S/L NSX250S/L	NSX100L NSX160L NSX250L	NSX100R NSX100R	NSX100R	-	-
Type of Canalis busbar trunking KSA250								
Isc max. in kA rms		10 kA	15 kA	20 kA	25 kA	45 kA	75 kA	100 kA
Type of circuit breaker	Compact NSX	NSX160N/H/S/L NSX250N/H/S/L NSX400F/N/H/S/L	NSX160S/L NSX250S/L NSX400H/S/L	NSX160L NSX250L NSX400H/S/L	- NSX250R -	- NSX250R	- NSX250HB1	- NSX250HB2
Type of Canalis busbar trunking KSA400								
Isc max. in kA rms		10 kA	15 kA	20 kA	25 kA	45 kA	75 kA	100 kA
Type of circuit breaker	Compact NSX	NSX250N/H/S/L NSX400F/N/H/S/L NSX630F/N/H/S/L	NSX250S/L NSX400F/N/H/S/L NSX630F/N/H/S/L	NSX250L NSX400H/S/L NSX630H/S/L	NSX250R NSX400S/L NSX630S/L	NSX250R NSX400R NSX630R	NSX250HB1 NSX400HB1 NSX400HB1	NSX250HB2 NSX400HB2 NSX400HB2
	Compact NS	NS630b N/H/LB	NS630b N/H/LB	NS630b N/H/LB	NS630bLB	NS630bLB	NS630bLB	-
Type of Canalis busbar trunking KSA500								
Isc max. in kA rms		10 kA	15 kA	20 kA	25 kA	45 kA	75 kA	100 kA
Type of circuit breaker	Compact NSX	NSX400F/N/H/S/L NSX630F/N/H/S/L		NSX400H/S/L NSX630H/S/L	NSX400S/L NSX630S/L	NSX400R NSX630R	NSX400HB1 NSX630HB1	NSX400HB2 NSX630HB2
	Compact NS	NS630b N/H/LB NS800N/H/LB				NS630b LB NS800LB		- -
Type of Canalis busbar trunking KSA630								
Isc max. in kA rms		10 kA	15 kA	20 kA	25 kA	45 kA	75 kA	100 kA
Type of circuit breaker	Compact NSX	NSX400F/N/H/S/L NSX630F/N/H/S/L	NSX400H/S/L NSX630H/S/L	NSX400H/S/L NSX630H/S/L	NSX400S/L NSX630S/L	NSX400R NSX630R	NSX400HB1 NSX630HB1	NSX400HB2 NSX630HB2
	Compact NS	NS630b N/H/LB NS800N/H/LB				NS630b LB NS800LB		- -
Type of Canalis busbar trunking KSA800								
Isc max. in kA rms		25 kA	30 kA	35 kA	45 kA	65 kA	75 kA	100 kA
Type of circuit breaker	Compact NSX	NSX400S/L/R/HB1/HB2 NSX630S/L/R/HB1/HB2	NSX400L/R/HB1/HB2 NSX630S/L/R/HB1/HB2	NSX400R/HB1/HB2 NSX630R/HB1/HB2		NSX400HB1/HB2 NSX630HB1/HB2		NSX400HB2 NSX630HB2
	Compact NS	NS630b N/H/LB NS800N/H/LB NS1000N/H		NS630b H/LB NS800H/LB NS1000H	NS630b LB NS800LB			- - -
	Masterpact MTZ1	MTZ1 06 H1/H2/L1 MTZ1 08 H1/H2/L1 MTZ1 10 H1/H2/L1	MTZ1 06 H1/H2 MTZ1 08 H1/H2 MTZ1 10 H1/H2		- - -	- - -	- - -	- - -
	Masterpact MTZ2	MTZ2 08 N1/H1/H2/L1 MTZ2 10 N1/H1/H2/L1			- -	- -	- -	- -
Type of Canalis busbar trunking KSA1000								
Isc max. in kA rms		25 kA	30 kA	35 kA	45 kA	65 kA	75 kA	100 kA
Type of circuit breaker	Compact NSX	NSX400S/L/R/HB1/HB2 NSX630S/L/R/HB1/HB2	NSX400L/R/HB1/HB2 NSX630L/R/HB1/HB2	NSX400R/HB1/HB2 NSX630R/HB1/HB2		NSX400HB1/HB2 NSX630HB1/HB2		NSX400HB2 NSX630HB2
	Compact NS	NS630b N/H/LB NS800N/H/LB NS1000N/H		NS630b H/LB NS800H/LB NS1000H	NS630b LB NS800LB			- - -
	Masterpact MTZ1	MTZ1 08 H1/H2/L1 MTZ1 10 H1/H2/L1 MTZ1 12 H1/H2	MTZ1 08 H1/H2 MTZ1 10 H1/H2 MTZ1 12 H1/H2		- - -	- - -	- - -	- - -
	Masterpact MTZ1	MTZ2 08 N1/H1/H2/L1 MTZ2 10 N1/H1/H2/L1 MTZ2 12 N1/H1/H2/L1			- - -	- - -	- - -	- - -

Characteristics and recommendations

Certification

Marine certification status

Certification	Range	
	Canalis KN	Canalis KS
	 <p>PD020221_KN</p>	 <p>PB115590-30</p>
 <p>ABS American Bureau of Shipping</p>	04-LD470214B/2-PDA	04-LD470214B/2-PDA
 <p>BV Bureau Veritas</p>	BV_19651C0	BV_19651C0
 <p>DNV (DNV-GL) Det Norske Veritas</p>	TAE000023F	TAE000023F
 <p>LR Lloyds Register of Shipping</p>	13-20001 (E1)	13-20001 (E1)
 <p>RINA Registro Italia Navale</p>	ELE174316CS001	ELE174316CS001

Installation

Characteristics and recommendations

Busbar trunking for medium power distribution

Assembly of trunking components rising mains from 100 to 1000 A

Assembling the straight lengths brackets

100 and 250 A

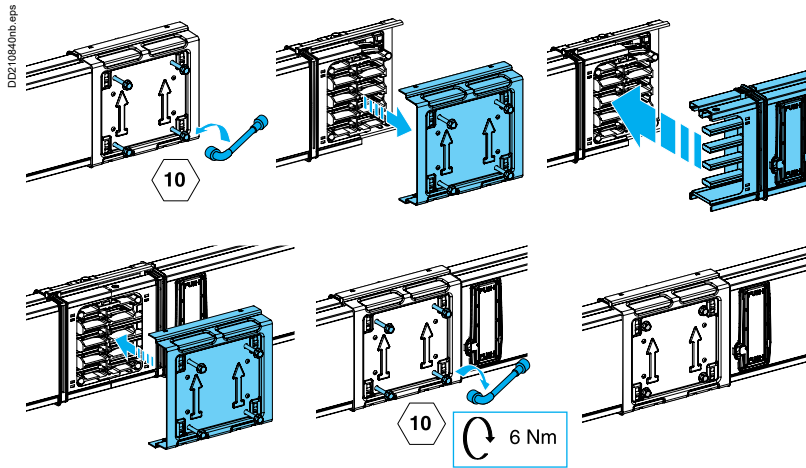

400 A

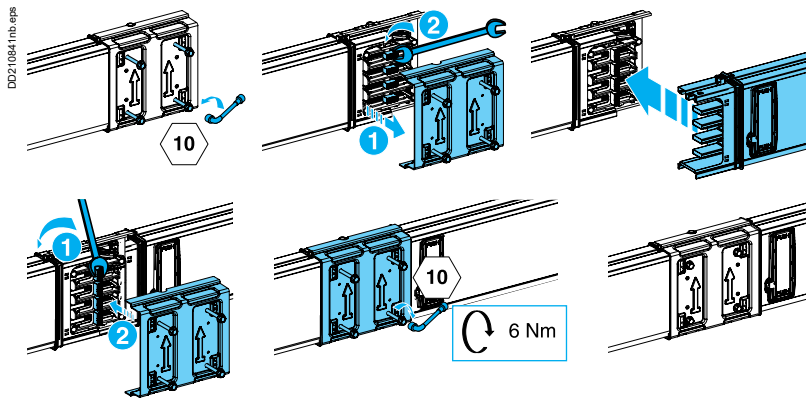

500 to 1000 A

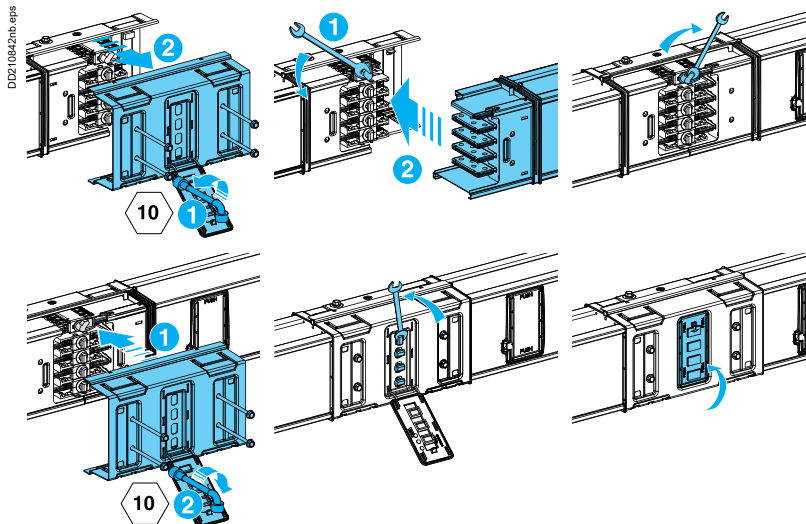

Characteristics and recommendations

Busbar trunking for medium power distribution

Assembly of trunking components rising mains from 100 to 1000 A

Connecting the feed-units

100 and 250 A

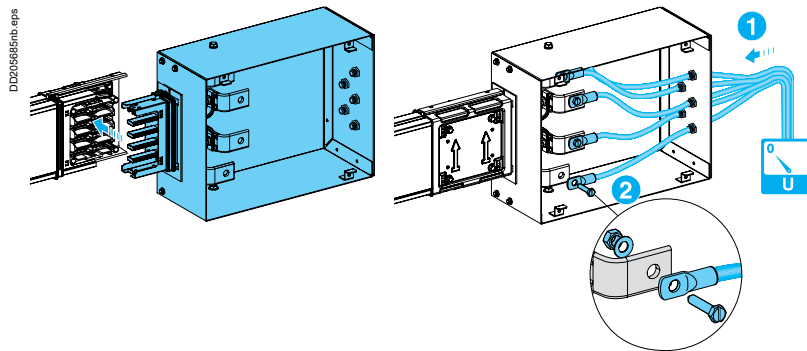

400 A

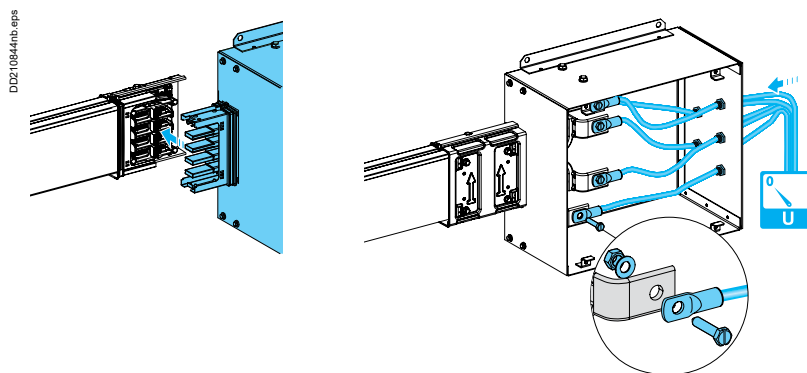

500 to 1000 A

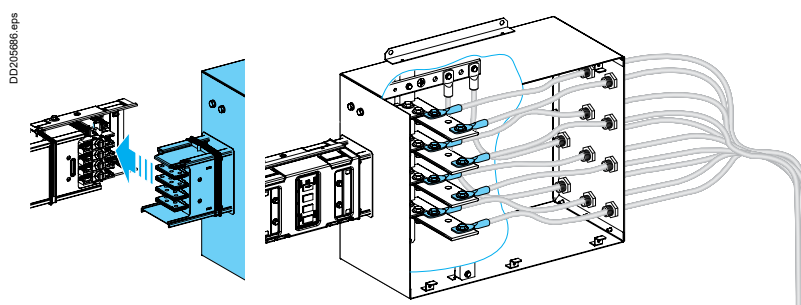

Characteristics and recommendations

Busbar trunking for medium power distribution

Assembly of trunking components rising mains from 100 to 1000 A

Assembling the end covers

100 to 400 A

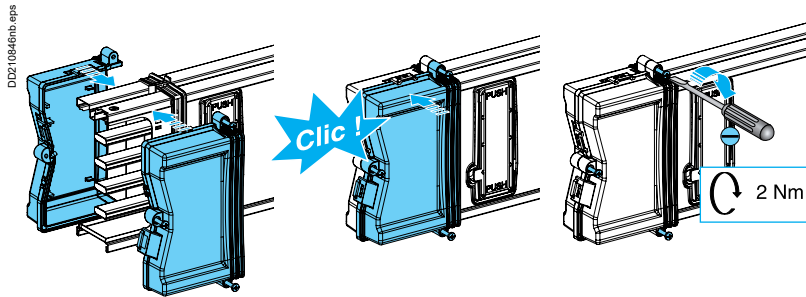

500 to 1000 A

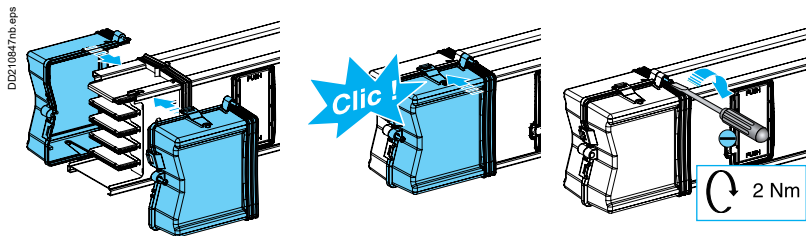

Fixing Canalis KS in the brackets

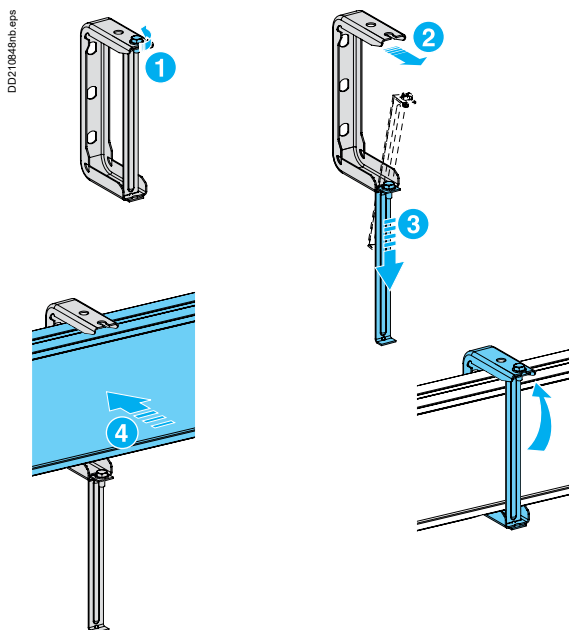

Characteristics and recommendations

Busbar trunking for medium power distribution

Assembly of trunking components rising mains from 100 to 1000 A

Mounting the tap-off unit

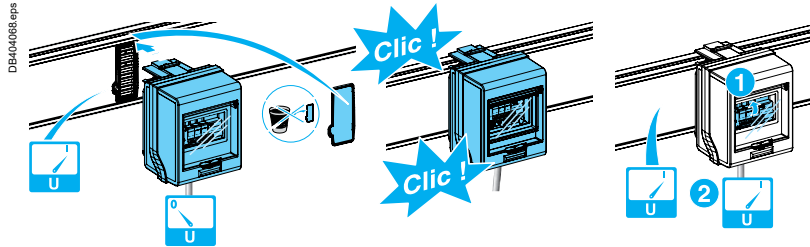

Mounting the tap-off unit with modular devices

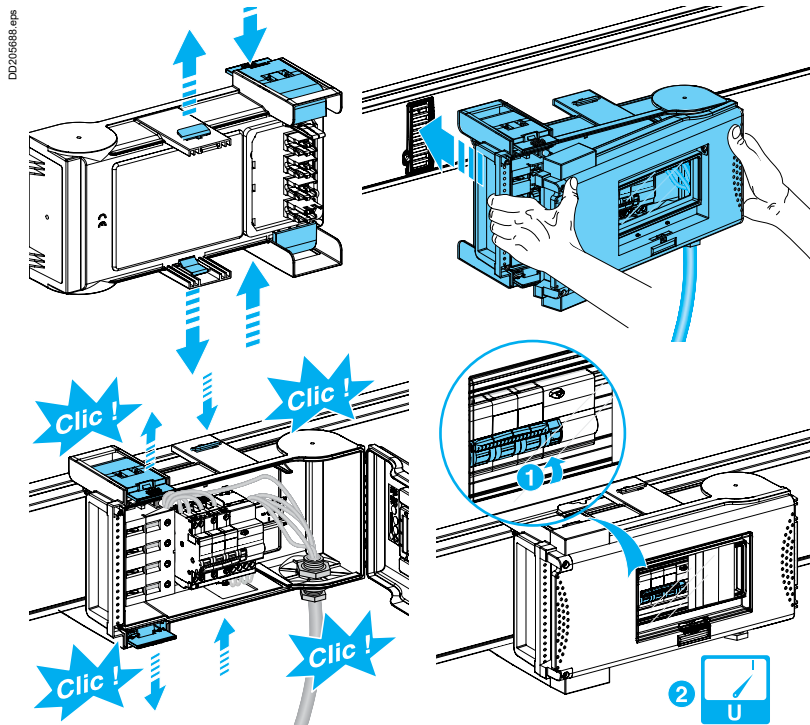

Characteristics and recommendations

Busbar trunking for medium power distribution

Assembly of trunking components rising mains from 100 to 1000 A

Mounting the tap-off unit with Compact NSX circuit breaker

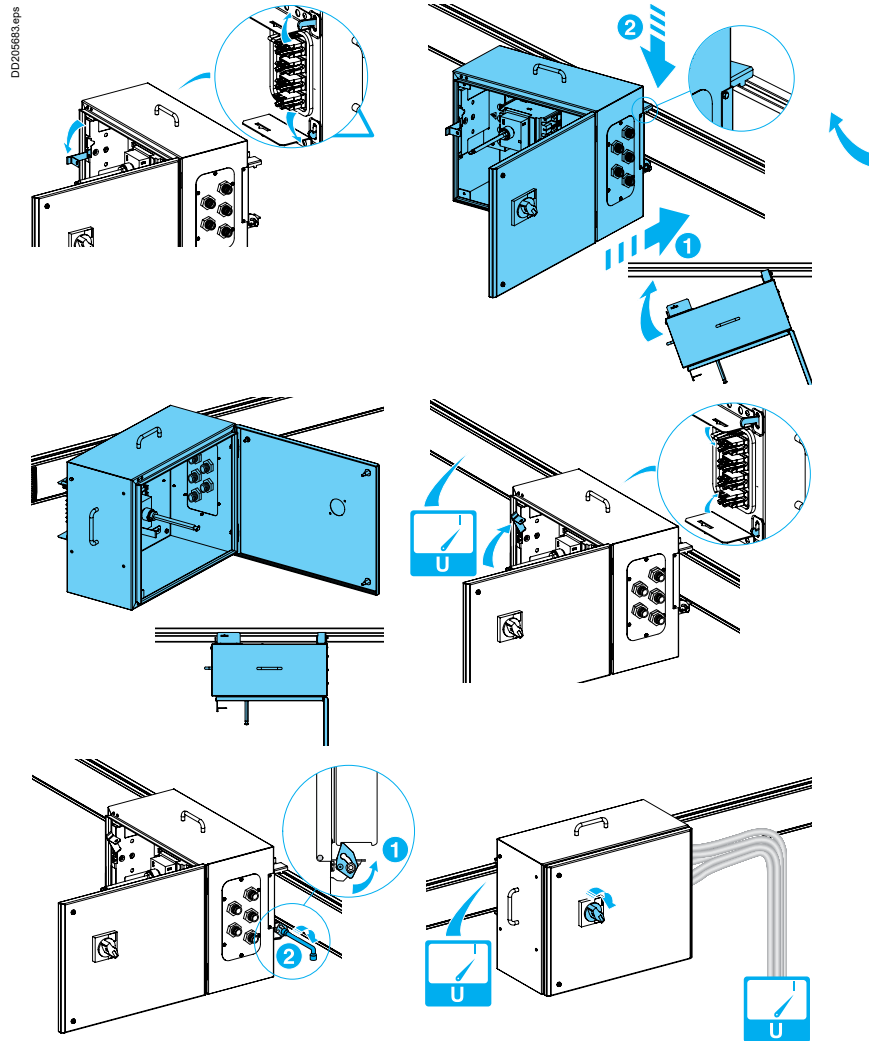

Characteristics and recommendations

Busbar trunking for medium power distribution

Assembly of trunking components rising mains from 100 to 1000 A

Mounting the bottom support

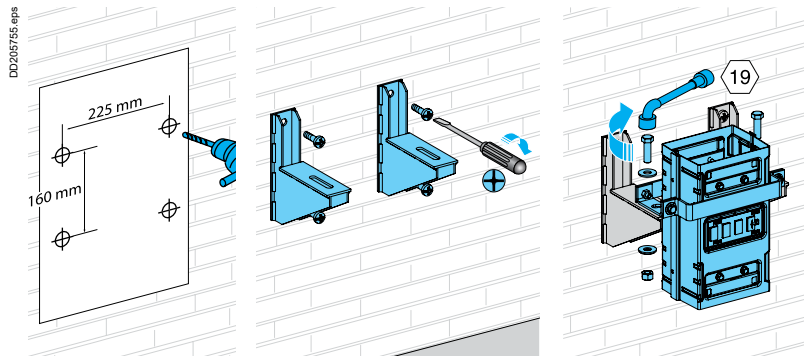

Connecting the feed-unit

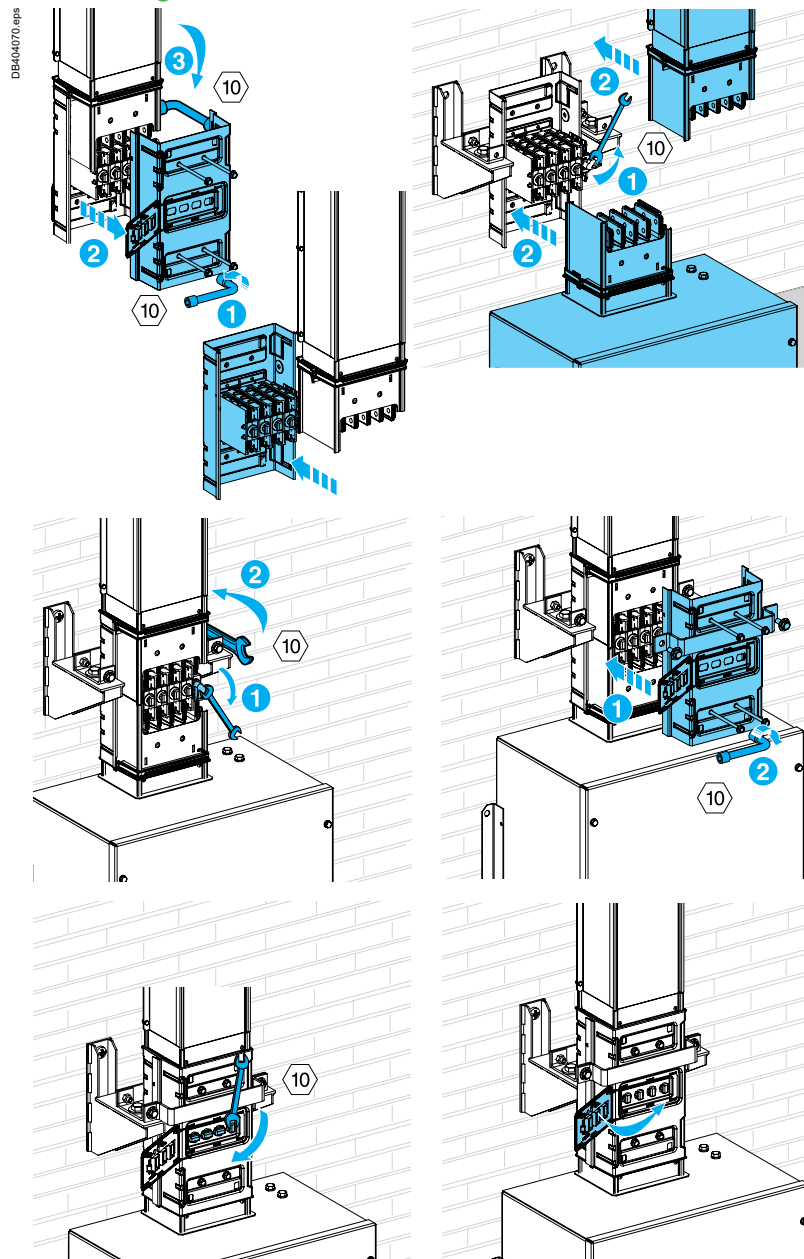

Characteristics and recommendations

Busbar trunking for medium power distribution

Assembly of trunking components rising mains from 100 to 1000 A

Mounting the fire barrier

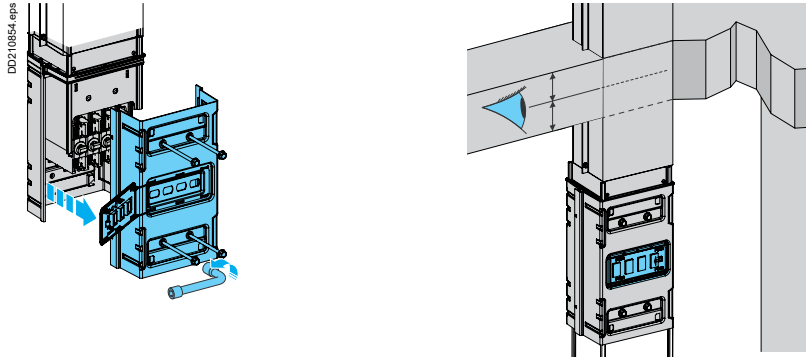

Position of the tap-off outlets

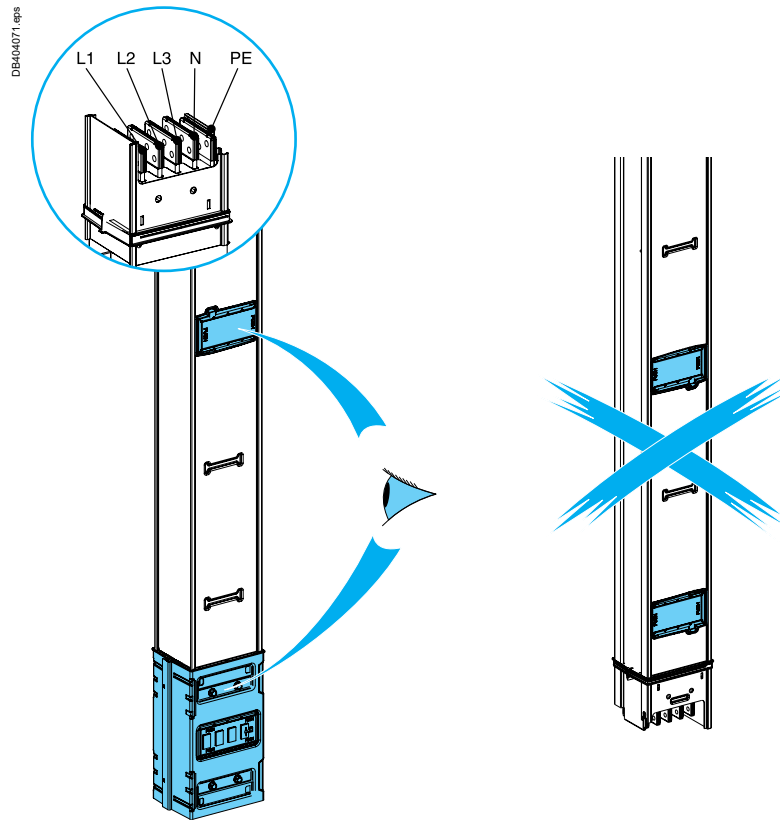

Fixing Canalis KS in the brackets

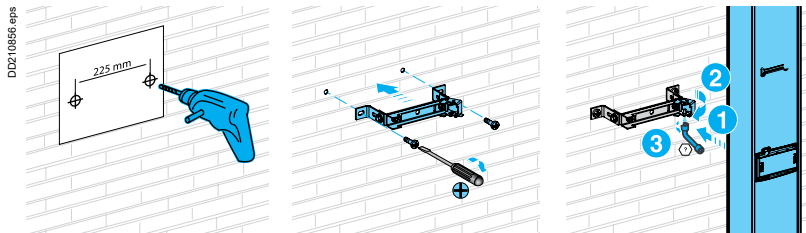

Mounting the tap-off units

For the mounting of Canalis KS tap-off units, see page 228

Storage

Busbar trunking for medium power distribution

Protection against humidity during storage

If the Canalis KS components are not installed immediately, follow these instructions for correct storage to avoid damage:

- Store the components in the original packing, in a clean, dry space with a constant temperature.
- If outdoor storage is unavoidable, cover the components securely to protect them from harsh environments. Provide temporary electrical heating under the cover to prevent condensation. The temperature must be suitable, and the heating must be evenly distributed under the cover.

Deserts can provide at least 2 specific situations for KS storage from standard other locations:

- Sand pollution.
- Significant thermal variations nights/days that can create condensation due to the colder busduct KS compared from atmosphere when it is humid (this risk should be evaluated from local context).

About sand:

When the products are not installed but in their standard transport packings, we can't completely guaranty the protection against sand/wind to not reach the products. As it's important to keep all electrical contacts clean from any foreign body and abrasion, our products must be protected from sand during storage period before and during installation.

The optional sea-packaging with wood boxes is including a waterproof system, it allows to keep the products protected against the 2 above risks.

Waterproof, anti-theft, and dust proof



Control temperature and humidity

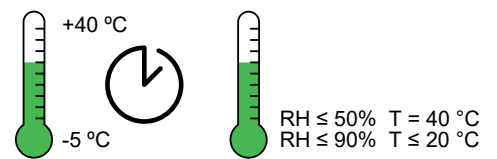

Indoor storage

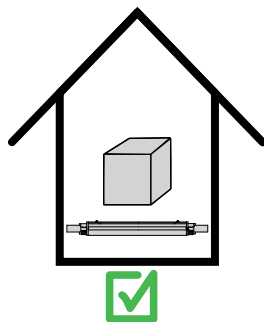

Outdoor storage

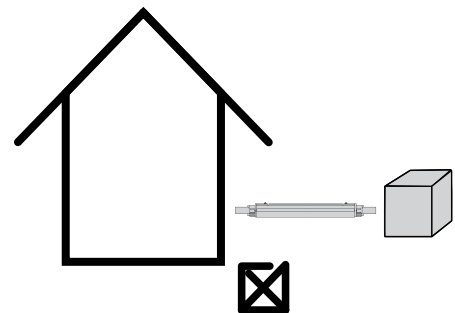

Maintenance

Characteristics and recommendations

Maintenance

Maintenance recommendations for your installation

Maintenance on power-distribution lines

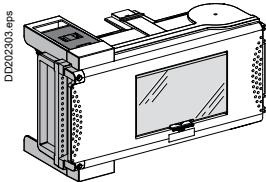
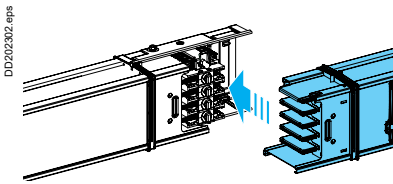
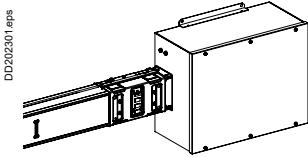

Feed units

They are equipped with terminals up to 100 A and lug connectors for higher ratings. As for all screw-type connections, it is advised to check tightness one year after installation and then run checks at longer intervals. The feed units are jointed to the first run component of the line (see next paragraph). This connection is maintenance free.

Run components

They are interconnected by electrical jointing units providing automatic and simultaneous connection of all live conductors. The contacts are clamp + spring type and exert no forces on the plastic parts. The electrical contacts of the jointing unit for the conductors are silver-plated copper. **This type of sliding connection is maintenance free.**

Components can be dismantled and reused.

Tap-off units

Trunking contacts are flexible, made of silver-plated clamps providing optimum contact quality. The contacts do not press or apply any forces on the plastic parts. They connect to the live line conductors at the tap-off outlets. Conductors are made of silver-plated copper at the point of contact. **These components are maintenance free.**

The connections for outgoing cables are made to terminals or using lugs. As for all screw-type connections, it is advised to check tightness one year after installation and then run checks at longer intervals.

Other recommendations

Maintenance of devices

For all devices installed in Canalis tap-off units, follow the manufacturer's instructions (as for installation in a switchboard).

Visual check

Cleaning

It is advised to check annually that trunking is clean and to remove any dust, water, oil or other conducting substances or objects from sensitive zones such as junctions, tap-off outlets and tap-off units.

External appearance

Check the external appearance of the trunking to detect:

- signs of shocks, in which case it is necessary to check the degree of protection to avoid any risk of insulation faults
- anomalies, i.e. incorrect implementation of the trunking (incorrect supports, etc.)
- traces of corrosion (in particular on supports).

Reuse after exposure to water

If a Canalis line is exposed to water during installation, it is necessary to measure the insulation resistance of the line by isolating the supply and the loads.

- If $R < 0.69 \text{ M}\Omega$, the installation must not be energised:
 - separate the line in two by removing the jointing unit in the middle
 - locate the affected zone
 - remove all jointing covers and dry the parts using compressed air
 - continue until the insulation resistance is greater than $0.69 \text{ M}\Omega$
 - the system can then be energised.

Special applications

Characteristics and recommendations

Recommendations for special applications

Direct current

Determining the DC current value

Thermal effect

Rule

The total power dissipated as heat must remain constant in the duct: $P_{ac} = P_{dc}$

Where:

- the power dissipated as heat: $P_{ac} = 3 \times R \times I_{ac}^2$ where:
 - R = resistance of a conductor
 - I_{ac} = conductor rms current
- the dissipated power for 4 conductors: $P_{dc} = 4 \times R \times I_{dc}^2$ where:
 - I_{dc} = direct current.

Selection table

■ 1 source

Case of 2 conductors in parallel for the + and 2 conductor in parallel for the - (only 1 circuit in the busbar trunking):

■ 2 sources

Case of 1 conductor for the + and 1 conductor for the - (2 circuits possible in the same busbar trunking):

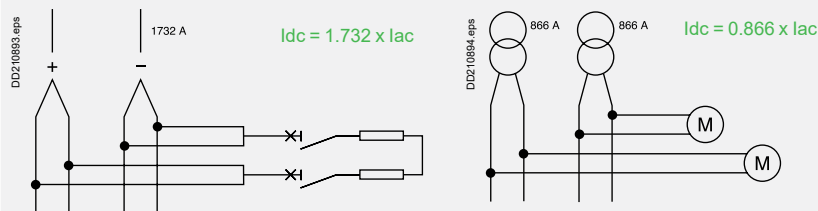

Rating (A)	1 source	2 sources
100	173	87
160	277	139
250	433	217
400	693	346
500	866	433
630	1091	546
800	1386	693
1000	1732	866

Protection

With DC, there is no zero crossing point of the voltage and current to facilitate arc extinction in the protective device.

The arcing time is longer and the energy that has to be absorbed is higher than for AC.

The voltage of the DC arc must rise to the source voltage very quickly in order to "put out" the short-circuit current.

"Shortened" electrical equation: $U_{network} = R \times I_{sc} + U_{arc}$ where:

- $I_{sc} = U_{network} - U_{arc} / R$
- $I_{sc} = 0$ when $U_{arc} = U_{network}$.

Use with specific switchgear

A quick rise in arcing voltage can be achieved by using series fuses, one fuse on the + and one fuse on the - of each circuit.

For some current rating and fuse characteristics, the placing of two fuses in series on each polarity may be specified (highly inductive circuit).

In some cases, two fuses must be placed in parallel for each polarity.

Characteristics and recommendations

Recommendations for special applications

Frequencies 400 Hz

KS busbar trunking derating at 400 Hz

Values at 35 °C.

Application of a derating coefficient at 400 Hz combined with that for temperature derating.

Busbar trunking derating at 400 Hz								
	KSA100	KSA160	KSA250	KSA400	KSA500	KSA630	KSA800	KSA1000
In (A)	92	146	221	342	403	514	621	745
Coefficient K at 400 Hz	0.92	0.91	0.88	0.85	0.81	0.82	0.78	0.74

Voltage drop

3-phase voltage drop, in millivolts per metre and per amp 400 Hz with load spread over the run.

For a concentration of load at the end of a run (transport), the voltage drops are double those shown in the table below.

Voltage drop when frequency is 400 Hz in millivolts per meter and per ampere								
	KSA100	KSA160	KSA250	KSA400	KSA500	KSA630	KSA800	KSA1000
Cos Φ = 1.0	0.992	0.641	0.550	0.388	0.225	0.226	0.201	0.160
Cos Φ = 0.9	0.975	0.627	0.546	0.388	0.223	0.225	0.200	0.159
Cos Φ = 0.8	0.968	0.622	0.545	0.387	0.222	0.224	0.200	0.159

Conductor characteristics

Conductor impedance at 400 Hz								
	KSA100	KSA160	KSA250	KSA400	KSA500	KSA630	KSA800	KSA1000
Average ohmic resistance of phase and neutral conductors at In Rb1ph (mΩ/m)	1.564	0.687	0.320	0.249	0.120	0.118	0.113	0.110
Average resistance at In Xph (mΩ/m)	1.203	1.207	1.264	0.942	0.535	0.551	0.506	0.405

Characteristics and recommendations

Recommendations for special applications

Fire resistance

As required by standards, busbar trunking complies with:

- 1 - material resistance to abnormal temperatures,
- 2 - flame propagation resistance,
- 3 - fire barrier function when going through a partition wall,
- 4 - conservation of all circuits for 1 h30 in an insulating sheath.

Definition of tests

1 - Insulating material resistance test to abnormal temperatures

Objective

To check a material will not be suspected as being the origin of a secondary fire outbreak. As defined in standards § 9.2 IEC 61439-6 and IEC 60695-2-10 and 2-13.

Method

Application of an incandescent wire for 30 seconds on the insulating materials in contact with live parts.

Result criteria

The specimen is considered to have passed the incandescent wire test if:

- if there is no visible flame and no sustained incandescence
- the specimen's flames and incandescence go out within 30 seconds of the incandescent wire being removed.

2 - Flame propagation resistance test

Objective

To check a busbar trunking will not create secondary fire outbreaks. As defined in standards § 9.101 IEC 61439-6 and IEC 60332 part 3.

Method

- Application of a flame for 40 minutes on a straight length of busbar trunking whose centre is located 2.5 metres from the edge of the burner.

Result criteria

The specimen is considered to have passed the test if:

- combustion does not occur
- the maximum extent of the burned part (external and internal) of the busbar trunking does not go beyond 2.5 metres above the lower edge of the burner.

3 - Fire barrier test through a partition wall

Objective

To check a busbar trunking will not propagate a fire from one room to another by crossing a fire barrier wall for 60, 120, 180, or 240 minutes. As defined in standard EN 1366-3; EN 1363-1; ISO 834; DIN 4102 part 9.

Method

The fire barrier busbar trunking section to be tested is placed in an oven which executes a standardised temperature-time curve.

Result criteria

The specimen is considered to have passed the test if:

- there are no flames behind the fire barrier
- there is no smoke or gas behind the fire barrier (not requested by the standard; can appear as a remark in the test report)
- the temperature rise of the casing behind the fire barrier does not exceed 180 °C.

4 - Conservation of all circuits in fire conditions test

Objective

To check all the busbar trunking's electrical circuits are preserved in fire conditions. As defined in standard DIN 4102 part 12.

Method

Its entire length inserted, the busbar trunking is taken as a specimen in an insulating sheath.

Result criteria

The specimen is considered to have passed the test if:

- conductor continuity is preserved
- there is no short-circuit between conductors.

Characteristics and recommendations

Recommendations for special applications

Harmonic currents

Origin of harmonic currents

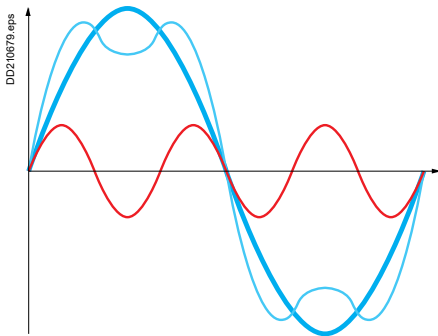

Harmonic currents are caused by non-linear loads connected to distribution systems, i.e. by loads that draw current with a waveform different that that of the voltage that supplies them.

The most common non-linear loads are equipment including rectifiers, fluorescent lighting and computer hardware.

In installations with a distributed neutral, non-linear loads may cause significant overloads in the neutral conductor due to the presence of third-order harmonics.

Harmonic order

The order is the ratio between the harmonic frequency f_n and the fundamental frequency (generally the power frequency, 50 or 60 Hz): $n = f_n / f_1$

By definition, the fundamental f_1 is order 1 (H1).

Third-order harmonics (H3) have a frequency of 150 Hz (when $f_1 = 50$ Hz).

Estimating THD (total harmonic distortion)

The presence of third-order harmonics depends on the applications involved. It is necessary to carry out an in-depth study on each non-linear load to determine the level of H3: $ih_3 (\%) = 100 \times i_3 / i_1$

■ i_3 = rms current of H3

■ i_1 = rms current of the fundamental

Assuming that H3 is preponderant among harmonics, the THD is close to the value of H3: $ih_3 (\%)$.

There are two decisive factors:

- the types of connected devices:
 - disturbing loads: fluorescent lighting, computer hardware, rectifiers, arc furnaces, etc.
 - non-disturbing loads: heating, motors, pumps, etc.
- the ratio between the two types of disturbing loads.



Workshops

Mix of disturbing loads (computers, UPSs, fluorescent lighting) and non-disturbing loads (motors, pumps, heating).

Low probability of harmonics

THD \leq 15 %.



Offices

Numerous disturbing loads (computers, UPSs, fluorescent lighting).

High probability of harmonics

15 % < THD \leq 33 %.

Characteristics and recommendations

Recommendations for special applications

Harmonic currents

Effects of harmonics on Canalis busbar trunking

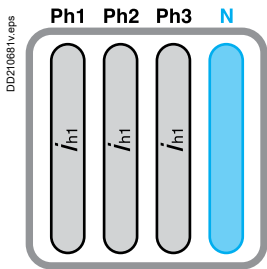

Fundamental frequency: i_{h1} (50 Hz)
 No current in the neutral.
 The conductors are correctly sized.

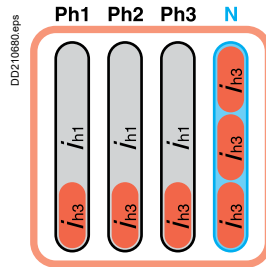

Fundamental frequency: i_{h1} (50 Hz) and 33 % of H3
 Abnormal temperature rise in the conductors caused by current at a higher frequency in the phases (skin effect) and current in the neutral caused by summing of the H3 harmonics.

The only effective solution

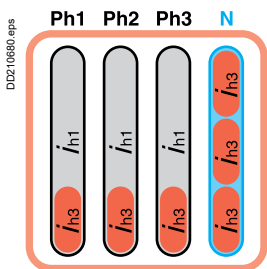

Fundamental frequency: i_{h1} (50 Hz) and 33 % H3

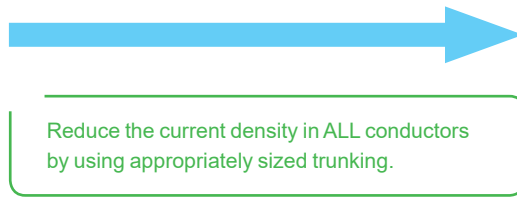

Reduce the current density in ALL conductors by using appropriately sized trunking.

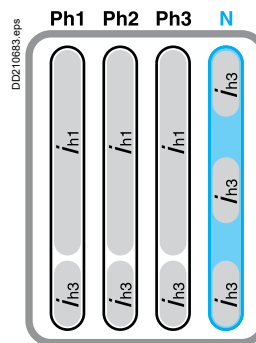

Busbar-trunking selection

THD ≤ 15 %	15 % < THD ≤ 33 %	THD > 33 %	Busbar trunking	Rating (A)
25	20	16	KBA / KBB	25
40	32	25	KBA / KBB	40
			KN	40
63	50	40	KN	63
100	80	63	KN	100
			KS	100
160	125	100	KS	160
250	200	160	KS	250
400	315	250	KS	400
500	400	315	KS	500
630	500	400	KS	630
800	630	500	KS	800
1000	800	630	KS	1000

Example: For a total rms current of **376 A**, (estimation based on power drawn by loads, including harmonics), the operational current is **400 A**. THD is estimated at 30 %. The appropriate trunking is **KS 500 A**.

Characteristics and recommendations

Recommendations for special applications

Canalis for all EV applications

A new concept for outdoor charging stations



The new energy landscape is bringing tremendous opportunities for electrification to contribute to sustainability goals. Canalis meets the demand for all types of infrastructure.

Canalis for EV offers several benefits compared to the standard solution through cables.

■ Canalis for EV offers several benefits compared to the standard solution through cables.

■ Flexible: compatible with all chargers, regardless of brand, power, etc.

■ Scalable: expandable whenever required

■ Simple: easy to select, easy to order, easy to transport, easy to install, maintain, and extend.

Characteristics and recommendations

Recommendations for special applications

Canalis for all EV applications

A new concept for outdoor charging stations



Indoor car park



Multi-storey car park

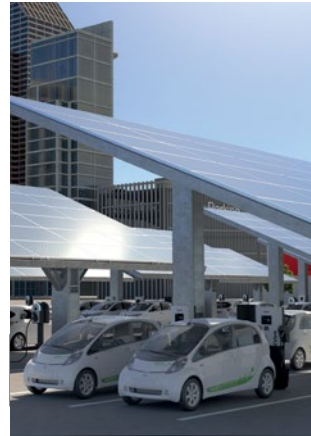

Under PV carport



Outdoor Charging Infrastructure

The large-scale deployment of charging infrastructure in outdoor car parks is needed to support the transition to electric vehicles.

Busbar trunking system is a suitable solution that is fast to install and expand. It can help you prepare you for future uncertainty.

Canalis for EV is a plug-and-play system, powered by Canalis KS and based on a modular design.

It is composed of prefabricated parts which are available through the distribution network.

For more information refer DEBU039EN – Canalis for EV Outdoor Charging Infrastructure.

Characteristics and recommendations

Recommendations for special applications

Sprinkler test certification

What is a sprinkler?

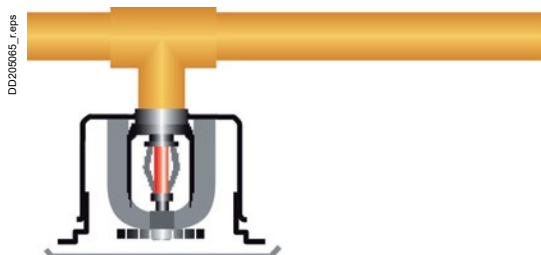

A sprinkler is a sprinkling device blanked off by a heat-sensitive component. It is designed to deliver water when the temperature to which it is subjected exceeds its calibration value.

The main aim of the installation is to lower the temperature in the accident area by wetting the ignited and adjacent materials by spraying water in the form of fine droplets.

The transformation of these droplets into water vapour captures a lot of energy from the fire and extinguishes it quickly. Moreover, this increased volume prevents air from flowing to the heart of the fire.

When a fire develops, ambient temperature rises to reach the calibration value. Water then leaves the sprinkler opening and strikes a deflector that projects it onto the fire in a certain form. Ground coverage ranges between 9 and 12 m² according to mounting height.

A sprinkler delivers between 60 and 120 l/min according to the hazard class.

On nuisance tripping lasting a few minutes, some hundreds of litres of water are released. IPx5 approval as per standard IEC 60529 does not guarantee non ingress of water in the busbar trunking in these conditions, as the water volumes, test duration and projection distance vary (nozzle 22.5 mm in diameter, at a distance of 2.5-3 m, with a water volume of 12.5 l/min for 1 min/m² for at least 3 min).

To provide you with all necessary guarantees, Schneider Electric has chosen to go further still than the IP55 test by subjecting its busbar trunking to an extremely severe "sprinkler" test.



Canalis KBA supplying luminaires nearby sprinklers.

Characteristics and recommendations

Recommendations for special applications

Sprinkler test certification

Sprinkler test procedure

PD202442W.eps

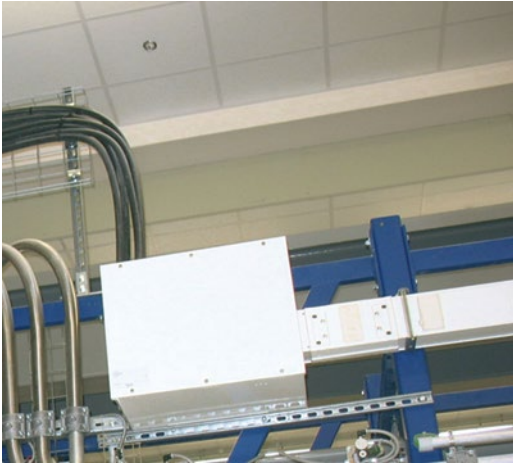

Canalis KS and sprinkler.

Chronology

In view of the absence of reference standard for sprinkler tests, we have chosen to apply the following procedure:

- insulation resistance test (1000 V)
- dielectric properties test (2.5 kV, 5 s: IEC 61439-1 & 6)
- water projection
- 5 min break
- insulation resistance test (1000 V)
- dielectric properties test (2.5 kV, 5 s: IEC 61439-1 & 6)

Water projection,

2 configurations, with or without energisation:

- horizontally installed busbar trunking:
 - 15 min water projection with sprinkler type K-Wert 115, NF ¾, 7.5 bar, 314 L/min
 - 35 min water projection with sprinkler type K-Wert 115, NF ¾, 1 bar, 115 L/min
- vertically installed busbar trunking:
 - 15 min water projection with sprinkler type K-Wert 80, NF ½, 7.5 bar, 314 L/min
 - 35 min water projection with sprinkler type K-Wert 80, NF ½, 1 bar, 80 L/min.

Mounting position

The distance between the sprinkler head and the busbar trunking is 500 mm.

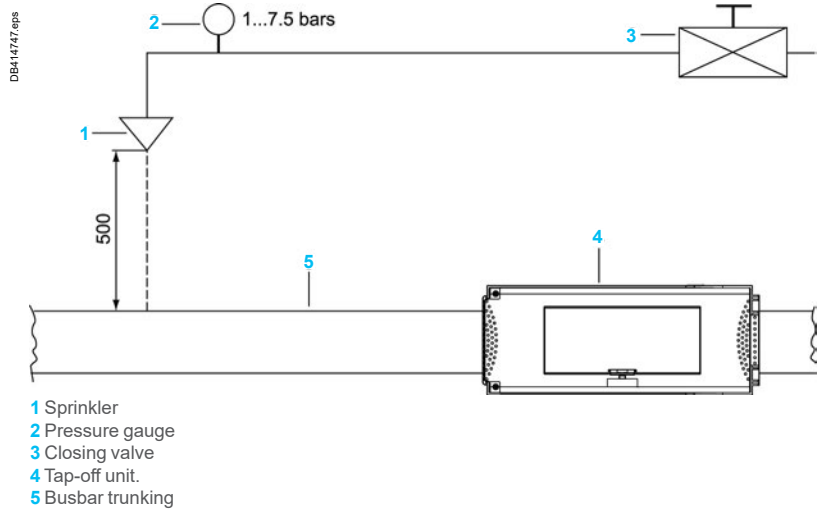

Test configuration

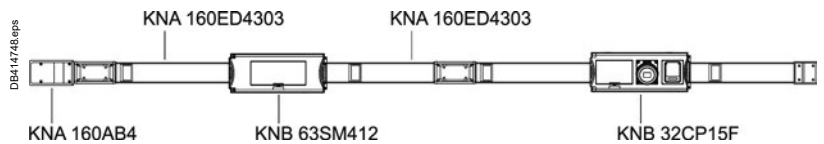

Test results

Busbar trunkings KBA, KBB, KN and KS have undergone the sprinkler test. This test, if successful, proves that our busbar trunkings can operate during and immediately after sprinkling of a line by a sprinkler for a period of 50 min.

Characteristics and recommendations

Recommendations for special applications

Measurements and metering: Canalis part of StruxureWare

Loads monitored by a power meter in tap-off units



Line capacity is managed in real time.
Information is available on the monitoring system.

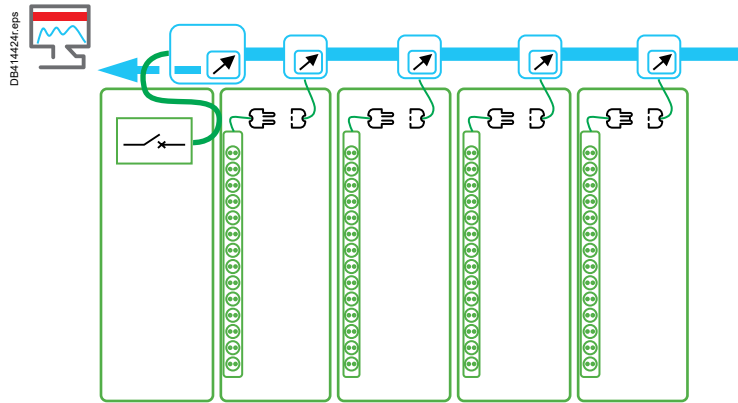

Functions available:

- Protection of Canalis lines by Compact NSX circuit breakers (100 A, 160 A, 250 A or 400 A rating).
- Protection of loads by circuit breakers from the Acti 9 range (single-phase or 3-phase 16 A, 32 A or 63 A) with or without differential protection (30 mA).
- Feed units are equipped with front panel-mounted sockets or wander sockets (IEC 309).
- For loads, measures power rate, phase balancing, THD, power factor, voltage, current, active and reactive power and consumption.



Compact NSX circuit breakers can be fitted with Micrologic power meter.

Architecture diagram:

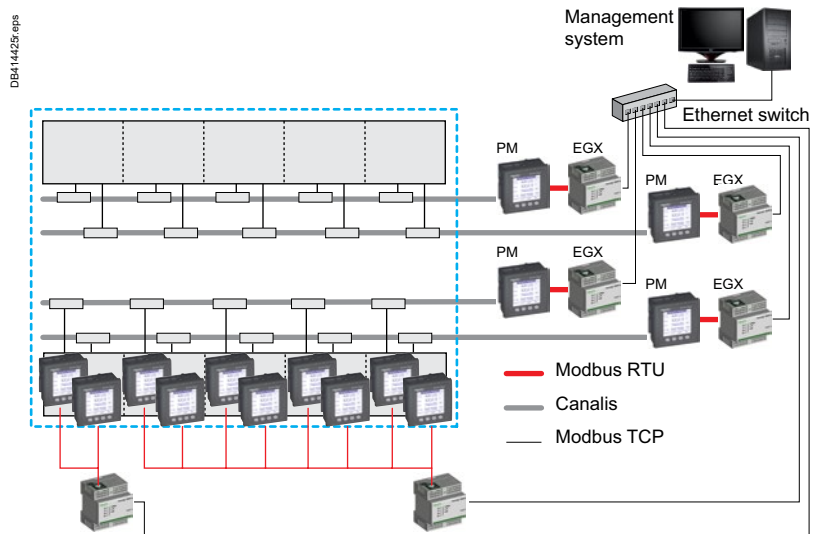

Characteristics and recommendations

Index

Replacement table

Former cat. numbers	New cat. numbers
KSA	
KSA02CF5	KSB32CF5
KSA02DA50010	KSB32CM55
KSA05AZ1	Cancelled
KSA05DA40010	KSB63SM48
KSA05DA50010	KSB63SM58
KSA05SF41	KSB50SF4
KSA05SF5	KSB50SF5
KSA1000DLC4A	KSA1000DLL41A
	KSA1000DLL42A
	KSA1000DLR41A
	KSA1000DLR42A
KSA1000DLC4B	KSA1000DLR43A
	KSA1000DLC43B
KSA1000DLC4CF	KSA1000DLL41F
	KSA1000DLL42F
	KSA1000DLR41F
	KSA1000DLR42F
	KSA1000DLR43F
KSA1000DLE4A	KSA1000DLE41A
	KSA1000DLE42A
	KSA1000DLE43A
KSA1000DLE4B	KSA1000DLE43B
	KSA1000DLE4CF
KSA1000DLE42F	
KSA1000DLE43F	
KSA1000DLF4A	KSA1000DLF41A
	KSA1000DLF42A
	KSA1000DLF43A
KSA1000DLF4B	KSA1000DLF43B
	KSA1000DLF4CF
KSA1000DLF42F	
KSA1000DLF43F	
KSA1000DMBK4A	
KSA1000DMBK4CF	KSA1000DMBK43A
	KSA1000DMBK41F
KSA1000DMBK4CF	KSA1000DMBK43F
	KSA1000DMBL4A
KSA1000DMBL43A	
KSA1000DMBL41F	
KSA1000DMBL4CF	KSA1000DMBL43F
	KSA1000DMCK4A
KSA1000DMCK43A	
KSA1000DMCK41F	
KSA1000DMCK4CF	KSA1000DMCK43F
	KSA1000DMCL4A
KSA1000DMCL43A	
KSA1000DMCL41F	
KSA1000DMCL4CF	KSA1000DMCL43F
	KSA1000DZCG4A
KSA1000DZCG43A	
KSA1000DZCG41F	
KSA1000DZCG4CF	KSA1000DZCG43F
	KSA1000DZCH4A
KSA1000DZCH43A	
KSA1000DZCH41F	
KSA1000DZCH4CF	KSA1000DZCH43F
	KSA1000DZE4A
KSA1000DZE43A	
KSA1000DZE41F	
KSA1000DZE4CF	KSA1000DZE43F
	KSA100AB451
KSA10DB40030	KSB100SM412
KSA10DB50030	KSB100SM512
KSA10EA430	KSA100ED4306
KSA10EA450	KSA100ED45010
KSA10SF41	KSB100SF4
KSA10SF5	KSB100SF5
KSA12AZ1	Cancelled
KSA12AZ2	Cancelled
KSA12AZ40	KSA12AZ40
KSA12HD502	KSB125HD502

Former cat. numbers	New cat. numbers
KSA12SF41	KSB100SF4
KSA12SF5	KSB160SF4
	KSB100SF5
KSA12SV4	KSB160SF5
	KSB100SV4
KSA12SV5	KSB160SV4
	KSB100SV5
KSA16AZ1	KSB160SV5
	Cancelled
KSA16AZ40	KSB160ZC1
KSA16DB411	KSB160DC4
KSA16DB412	KSB160DB412
KSA16DB511	KSB160DC5
KSA16DB512	KSB160DB512
KSA16EA430	KSA160ED4306
KSA16EA450	KSA160ED45010
KSA16SF3	KSB160SF4
KSA16SF41	KSB160SF4
KSA16SF5	KSB160SF5
KSA250DLC4A	KSA250DLL41A
	KSA250DLL42A
	KSA250DLR41A
	KSA250DLR42A
KSA250DLC4B	KSA250DLR43A
	KSA250DLC43B
KSA250DLC4CF	KSA250DLL41F
	KSA250DLL42F
	KSA250DLR41F
	KSA250DLR42F
	KSA250DLR43F
KSA250DLE4A	KSA250DLE41A
	KSA250DLE42A
	KSA250DLE43A
KSA250DLE4B	KSA250DLE43B
	KSA250DLE4CF
KSA250DLE42F	
KSA250DLE43F	
KSA250DLF4A	KSA250DLF41A
	KSA250DLF42A
	KSA250DLF43A
KSA250DLF4B	KSA250DLF43B
	KSA250DLF4CF
KSA250DLF42F	
KSA250DLF43F	
KSA250DMBK4A	KSA250DMBK41A
KSA250DMBK4CF	KSA250DMBK43A
	KSA250DMBK41F
KSA250DMBK4CF	KSA250DMBK43F
	KSA250DMBL4A
KSA250DMBL43A	
KSA250DMBL41F	
KSA250DMBL4CF	KSA250DMBL43F
	KSA250DMCK4A
KSA250DMCK43A	
KSA250DMCK41F	
KSA250DMCK4CF	KSA250DMCK43F
	KSA250DMCL4A
KSA250DMCL43A	
KSA250DMCL41F	
KSA250DMCL4CF	KSA250DMCL43F
	KSA250DZCG4A
KSA250DZCG43A	
KSA250DZCG41F	
KSA250DZCG4CF	KSA250DZCG43F
	KSA250DZCH4A
KSA250DZCH43A	
KSA250DZCH41F	
KSA250DZCH4CF	KSA250DZCH43F
	KSA250DZE4A
KSA250DZE43A	
KSA250DZE41F	
KSA250DZE4CF	KSA250DZE43F
	KSA100AB4
KSA10DB40030	KSB100SM412
KSA10DB50030	KSB100SM512
KSA10EA430	KSA100ED4306
KSA10EA450	KSA100ED45010
KSA10SF41	KSB100SF4
KSA10SF5	KSB100SF5
KSA12AZ1	Cancelled
KSA12AZ2	Cancelled
KSA12AZ40	KSA12AZ40
KSA12HD502	KSB125HD502

Characteristics and recommendations

Index

Replacement table

Former cat. numbers	New cat. numbers
KSA25BT42	KSA250ABT4
KSA25DB411	KSB250DC4
KSA25DB412	KSB400DB412
KSA25DB511	KSB250DC5
KSA25DB512	KSB400DB512
KSA25EB430	KSA250ED4306
KSA25EB450	KSA250ED45010
KSA25ED415	KSA250ED4156
KSA25ED420	KSA250ED4208
KSA25EF4A	KSA250ET4AF
KSA25ER4	KSA250AE4
KSA25ES4A	KSA250ET4A
KSA25EZ1	KSB400ZF1
KSA25HD502	KSB250HD502
KSA25LC40	KSA250DLC40
KSA25LP41	KSA250DLE40
KSA25LP42	KSA250DLF40
KSA25SF3	KSB250SE4
KSA25SF41	KSB250SE4
KSA25SF5	KSB250SE5
KSA25TC40	KSA250DTC40
KSA25XC40	KSA250DXC40
KSA40HD502	KSB400HD502
KSA400DLC4A	KSA400DLL41A KSA400DLL42A KSA400DLR41A KSA400DLR42A KSA400DLR43A
KSA400DLC4B	KSA400DLC43B
KSA400DLC4CF	KSA400DLL41F KSA400DLL42F KSA400DLR41F KSA400DLR42F KSA400DLR43F
KSA400DLE4A	KSA400DLE41A KSA400DLE42A KSA400DLE43A
KSA400DLE4B	KSA400DLE43B
KSA400DLE4CF	KSA400DLE41F KSA400DLE42F KSA400DLE43F
KSA400DLF4A	KSA400DLF41A KSA400DLF42A KSA400DLF43A
KSA400DLF4B	KSA400DLF43B
KSA400DLF4CF	KSA400DLF41F KSA400DLF42F KSA400DLF43F
KSA400DMBK4A	KSA400DMBK41A KSA400DMBK43A
KSA400DMBK4CF	KSA400DMBK41F KSA400DMBK43F
KSA400DMBL4A	KSA400DMBL41A KSA400DMBL43A
KSA400DMBL4CF	KSA400DMBL41F KSA400DMBL43F
KSA400DMCK4A	KSA400DMCK41A KSA400DMCK43A
KSA400DMCK4CF	KSA400DMCK41F KSA400DMCK43F
KSA400DMCL4A	KSA400DMCL41A KSA400DMCL43A
KSA400DMCL4CF	KSA400DMCL41F KSA400DMCL43F
KSA400DZCG4A	KSA400DZCG41A KSA400DZCG43A
KSA400DZCG4CF	KSA400DZCG41F KSA400DZCG43F
KSA400DZCH4A	KSA400DZCH41A KSA400DZCH43A

Former cat. numbers	New cat. numbers
KSA400DZCH4CF	KSA400DZCH41F KSA400DZCH43F
KSA400DZE4A	KSA400DZE41A KSA400DZE43A
KSA400DZE4CF	KSA400DZE41F KSA400DZE43F
KSA40AZ1	Cancelled
KSA40DB411	KSB400DC4
KSA40DB412	KSB400DB412
KSA40DB511	KSB400DC5
KSA40DB512	KSB400DB512
KSA40ED430	KSA400ED4306
KSA40ED450	KSA400ED45010
KSA40SF3	KSB400SE4
KSA40SF41	KSB400SE4
KSA40SF5	KSB400SE5
KSA50AB452	KSA400AB4
KSA50AB462	KSA630ABD4
KSA50AB462	KSA400AB4
KSA50AB462	KSA630ABG4
KSA50BT402	KSA630ABT4
KSA50ED415	KSA400ED4156
KSA50ED415	KSA630ED4154
KSA50ED420	KSA400ED4208
KSA50ED420	KSA630ED4206
KSA50ED430	KSA500ED4306
KSA50ED450	KSA500ED45010
KSA50EF4A	KSA500ET4AF
KSA50ER4	KSA630AE4
KSA50ES4A	KSA630ET4A
KSA50LC40	KSA630DLC40
KSA50LP41	KSA630DLE40
KSA50LP42	KSA630DLF40
KSA50TC40	KSA630DTC40
KSA50XC40	KSA630DXC40
KSA630DLC4A	KSA630DLL41A KSA630DLL42A KSA630DLR41A KSA630DLR42A KSA630DLR43A
KSA630DLC4B	KSA630DLC43B
KSA630DLC4CF	KSA630DLL41F KSA630DLL42F KSA630DLR41F KSA630DLR42F KSA630DLR43F
KSA630DLE4A	KSA630DLE41A KSA630DLE42A KSA630DLE43A
KSA630DLE4B	KSA630DLE43B
KSA630DLE4CF	KSA630DLE41F KSA630DLE42F KSA630DLE43F
KSA630DLF4A	KSA630DLF41A KSA630DLF42A KSA630DLF43A
KSA630DLF4B	KSA630DLF43B
KSA630DLF4CF	KSA630DLF41F KSA630DLF42F KSA630DLF43F
KSA630DMBK4A	KSA630DMBK41A KSA630DMBK43A
KSA630DMBK4CF	KSA630DMBK41F KSA630DMBK43F
KSA630DMBL4A	KSA630DMBL41A KSA630DMBL43A
KSA630DMBL4CF	KSA630DMBL41F KSA630DMBL43F
KSA630DMCK4A	KSA630DMCK41A KSA630DMCK43A

Characteristics and recommendations

Index

Replacement table

Former cat. numbers	New cat. numbers
KSA630DMCK4CF	KSA630DMCK41F KSA630DMCK43F
KSA630DMCL4A	KSA630DMCL41A KSA630DMCL43A
KSA630DMCL4CF	KSA630DMCL41F KSA630DMCL43F
KSA630DZCG4A	KSA630DZCG41A KSA630DZCG43A
KSA630DZCG4CF	KSA630DZCG41F KSA630DZCG43F
KSA630DZCH4A	KSA630DZCH41A KSA630DZCH43A
KSA630DZCH4CF	KSA630DZCH41F KSA630DZCH43F
KSA630DZE4A	KSA630DZE41A KSA630DZE43A
KSA630DZE4CF	KSA630DZE41F KSA630DZE43F
KSA63ED430	KSA630ED4306
KSA63ED450	KSA630ED45010
KSA63SF41	KSB630SE4
KSA63SF5	KSB630SE5
KSA80EF4A	KSA800ET4AF
KSA80ER4	KSA1000AE4
KSA80ES4A	KSA1000ET4A
KSA80EZ3	KSB1000ZF1
KSA80LC40	KSA1000DLC40
KSA80LP41	KSA1000DLE40
KSA80LP42	KSA1000DLF40
KSA80TC40	KSA1000DTC40
KSA80XC40	KSA1000DXC40

KSB

KSB25FA3	KSA400AF1
KSB25YA4	KSB25YA4
KSB50FA2	KSA800AF1
KSB50YA4	KSB50YA4
KSB80FA2	KSA1000AF1
KSB80YA4	KSB80YA4

KSE

KSE02CD5	KSB16CN5
KSE02CF5	KSB32CF5
KSE02CG5	KSB20CG5
KSE02SD41	KSB25SD4
KSE02SD5	KSB25SD5
KSE03SG41	KSB32SG4
KSE05DA4	KSB63SM48
KSE05DA5	KSB63SM58
KSE05SD41	KSB50SN4
KSE05SD5	KSB50SN5
KSE05SF41	KSB50SF4
KSE05SF5	KSB50SF5
KSE06SD41	KSB63SD4
KSE06SD5	KSB63SD5
KSE08SG41	KSB80SG4
KSE10DA4	KSB100SM412
KSE10DA5	KSB100SM512
KSE10SD41	KSB100SE4
KSE10SD5	KSB100SE5
KSE10SF41	KSB100SF4
KSE10SF5	KSB100SF5
KSE16DB411	KSB160DC4
KSE16DB511	KSB160DC5
KSE16SD3	KSB160SE4

Former cat. numbers	New cat. numbers
KSE16SD41	KSB160S E4
KSE16SD5	KSB160SE5
KSE16SF3	KSB160SF4
KSE16SF41	KSB160SF4
KSE16SF5	KSB160SF5
KSE16SG41	KSB160SG4
KSE25DB411	KSB250DC4
KSE25DB511	KSB250DC5
KSE25SF3	KSB250SE4
KSE25SF41	KSB250SE4
KSE25SF5	KSB250SE5
KSE25YA2	KSE25YA2
KSE25YA3	KSE25YA3
KSE40DB411	KSB400DC4
KSE40DB511	KSB400DC5
KSE40SF3	KSB400SE4
KSE40SF41	KSB400SE4
KSE40SF5	KSB400SE5
KSE80YA2	KSE80YA2

Notes



Schneider Electric Industries SAS

35, rue Joseph Monier
CS 30323
92506 Rueil Malmaison Cedex (France)

RCS Nanterre 954 503 439
Capital social 896 313 776 €
www.schneider-electric.com

07-2025
DEBU026EN

© 2025- Schneider Electric - All rights reserved.
All trademarks are owned by Schneider Electric Industries SAS or its affiliated companies.

This document has been
printed on recycled paper.

