

MV-CS020-10GM/GC

2 MP 1/1.7" CMOS GigE Area Scan Camera



GEN*i*CAM

GigE
VISION

Introduction

MV-CS020-10GM/GC camera adopts Sony® IMX430 sensor to provide high-quality images. It uses GigE interface to transmit non-compressed images in real time, and its max. frame rate can reach 60 fps in full resolution.

Key Feature

- Adopts brand new design to reduce power consumption.
- Compact design with mounting holes on panels for flexible mounting from 4 sides.
- Supports sequencer, contrast ratio, super palette, etc.
- Supports hard trigger, software trigger, free run, etc.
- Compatible with GigE Vision V2.0 Protocol, GenICam Standard, and third-party software based on the protocol and standard.

Available Model

- Mono: MV-CS020-10GM
- Color: MV-CS020-10GC

Applicable Industry

Electronic semiconductor, new energy, medical packaging, etc.

Sensor Quantum Efficiency

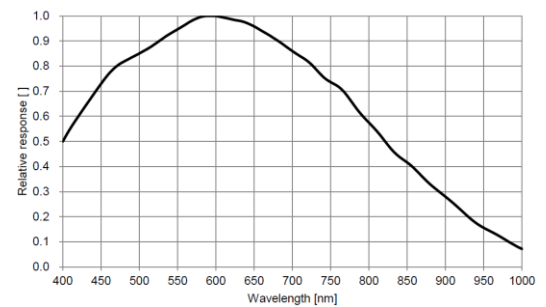

MV-CS020-10GM

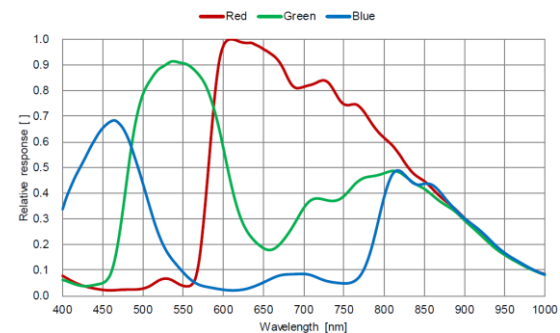

MV-CS020-10GC

Dimension

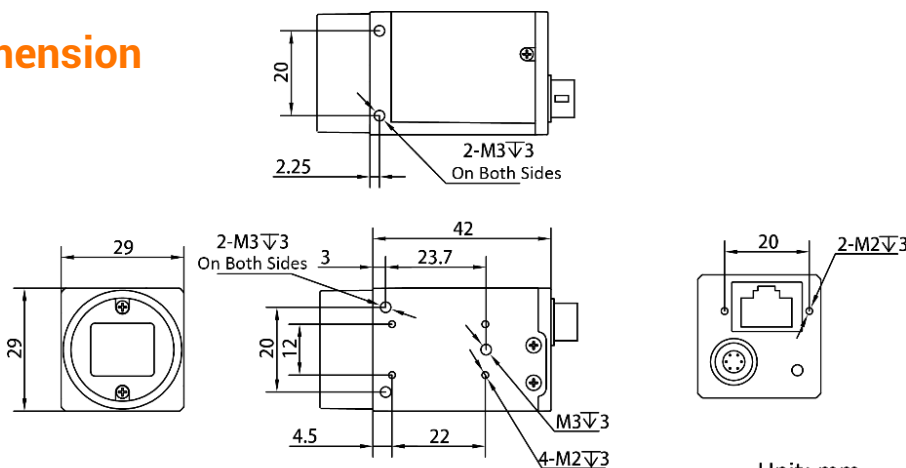

Unit: mm

Specification

Model	MV-CS020-10GM	MV-CS020-10GC
Camera		
Sensor type	CMOS, global shutter	
Sensor model	Sony® IMX430	
Pixel size	4.5 μm × 4.5 μm	
Sensor size	1/1.7"	
Resolution	1624 × 1240	
Max. frame rate	60 fps @ 624 × 1240 Mono 8	60 fps @ 624 × 1240 Bayer RG 8
Dynamic range	72.1 dB	
SNR	43.8 dB	
Gain	0 dB to 24 dB	
Exposure time	UltraShort exposure mode: 1 μs to 5 μs	
	Standard exposure mode: 6 μs to 10 sec	
Exposure mode	Off/Once/Continuous exposure mode	
Mono/color	Mono	Color
Pixel format	Mono 8/10/10Packed/12/12Packed	Mono 8/10/12, Bayer RG 8/10/10Packed/12/12Packed, YUV422Packed, YUV422_YUYV_Packed RGB 8, BGR 8
Binning	Supports 1 × 1, 2 × 2	
Decimation	Supports 1 × 1, 2 × 2	
Reverse image	Supports horizontal and vertical reverse image output	
Electrical features		
Data interface	Gigabit Ethernet, compatible with Fast Ethernet	
Digital I/O	6-pin P7 connector provides power and I/O, including opto-isolated input × 1 (Line 0), opto-isolated output × 1 (Line 1), bi-directional non-isolated I/O × 1 (Line 2).	
Power supply	9 VDC to 24 VDC, supports PoE	
Power consumption	Typ. 2.8 W @ 12 VDC	Typ. 3.0 W @ 12 VDC
Mechanical		
Lens mount	C-mount	
Dimension	29 mm × 29 mm × 42 mm (1.1" × 1.1" × 1.2")	
Weight	Approx. 100 g (0.22 lb.)	
Ingress protection	IP40 (under proper lens installation and wiring)	
Temperature	Working temperature: -30 °C to 60 °C (-22 °F to 140 °F)	
	Storage temperature: -30 °C to 70 °C (-22 °F to 158 °F)	
Humidity	20% RH to 95% RH (no condensation)	
General		
Client software	MVS or third-party software meeting with GigE Vision Protocol	
Operating system	32/64-bit Windows 7/10, 32/64-bit Linux	
Compatibility	GigE Vision V2.0, GenICam	
Certification	CE, RoHS, KC	