

# Vacuum Ejector

## ZH Series

### Box Type (Built-in Silencer)/Body Ported Type

Body ported type has been remodeled.  
Please refer to page 221 for details.

Nozzle diameter:  $\varnothing 0.5, \varnothing 0.7, \varnothing 1.0, \varnothing 1.3, \varnothing 1.5, \varnothing 1.8, \varnothing 2.0$   
Type S: Standard type  
L: Large flow type

ZK2
ZQ
ZR
ZB
ZA
ZX
ZM
ZL
ZH
ZH
ZH-X267
ZHP
ZU
VQD-V

## Compact and lightweight

The nozzle and the body, which have been made into a composite resin construction, are compact and lightweight.  
Nozzle diameter  $\varnothing 0.5 \sim 28$  g

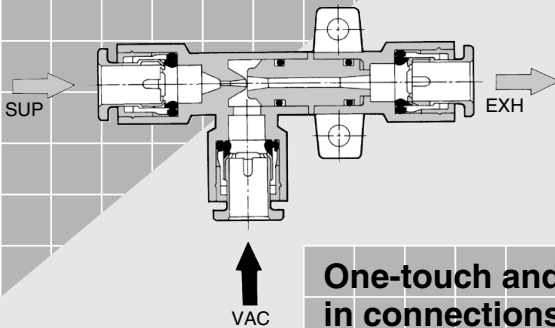

## Box type (Built-in silencer) Body ported

Two types are available in the series: the box type with a silencer exhaust, and the body ported type, with an individual exhaust.

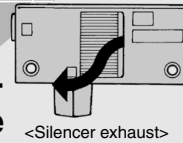

## One-touch and screw-in connections can be combined.

To suit the operating conditions, port connections can be combined with a choice of one-touch and screw-in connections.

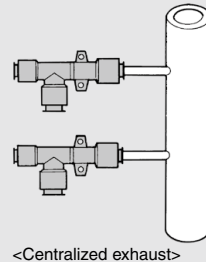

## Body can be mounted and secured.

The body ported type is also provided with mounting holes for securing the body.

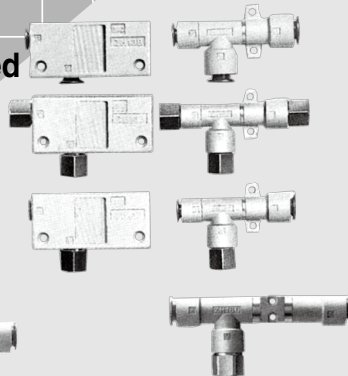
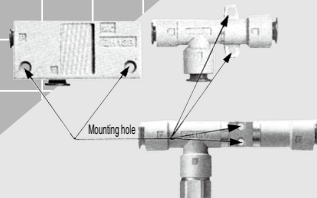

# Vacuum Ejector Box Type (Built-in Silencer)/Body Ported Type **ZH Series**



Body ported type has been remodeled.  
Please refer to page 221 for details.

## How to Order

**Note** Refer to "Table (1)" and "(2)" for the combination available for SUP, VAC and EXH port connection.



Box type  
(Built-in silencer)

ZH **07** B S - **06** - **06**

Body ported type  
(Without silencer)

ZH **07** D S - **01** - **01** - **01**



Nozzle diameter

05	0.5
07	0.7
10	1.0
13	1.3
15	1.5
18	1.8
20	2.0

Maximum vacuum pressure

S	-88 kPa
L	-48 kPa

SUP. port size <sup>Note)</sup>

Symbol	Size	Style
06	6	One-touch
08	8	One-touch
10	10	One-touch
12	12	One-touch
01	Rc 1/8	Screw-in
02	Rc 1/4	Screw-in
03	Rc 3/8	Screw-in
F01	G 1/8	Screw-in
F02	G 1/4	Screw-in
F03	G 3/8	Screw-in

VAC. port size <sup>Note)</sup>

Symbol	Size	Style
06	6	One-touch
10	10	One-touch
12	12	One-touch
16	16	One-touch
01	Rc 1/8	Screw-in
02	Rc 1/4	Screw-in
03	Rc 3/8	Screw-in
04	Rc 1/2	Screw-in
F01	G 1/8	Screw-in
F02	G 1/4	Screw-in
F03	G 3/8	Screw-in
F04	G 1/2	Screw-in

EXH. port size <sup>Note)</sup>

Symbol	Size	Style
06	6	One-touch
08	8	One-touch
10	10	One-touch
12	12	One-touch
16	16	One-touch
01	Rc 1/8	Screw-in
02	Rc 1/4	Screw-in
03	Rc 3/8	Screw-in
04	Rc 1/2	Screw-in
F01	G 1/8	Screw-in
F02	G 1/4	Screw-in
F03	G 3/8	Screw-in
F04	G 1/2	Screw-in

**Note)** Do not make the piping diameter smaller, such as by connecting a reducer to the exhaust port, etc., since it may lower the performance.

\* The thread ridge shape is conforming to G thread standard (JIS B 0202), but other shapes are not conforming to ISO16030 and ISO1179.

**Table (1) Combination of Connection**

Body type		SUP	VAC	EXH
Box type (Built-in silencer)	1	One-touch	One-touch	-
	2	One-touch	Screw-in	-
	3	Screw-in	Screw-in	-
Body ported type (Without silencer)	1	One-touch	One-touch	One-touch
	2	One-touch	Screw-in	One-touch
	3	Screw-in	Screw-in	Screw-in

**Table (2) Port Size**

Model	Connection (One-touch/Screw-in)		
	SUP	VAC	EXH
ZH05B	ø6, Rc 1/8 G 1/8	ø6, Rc 1/8 G 1/8	-
ZH07B			
ZH10B			
ZH13B	ø8, Rc 1/8 G 1/8	ø10, Rc 1/4 G 1/4	-
ZH15B			
ZH18B			
ZH05D	ø6, Rc 1/8 G 1/8	ø6, Rc 1/8 G 1/8	ø6, Rc 1/8 G 1/8
ZH07D			
ZH10D			
ZH13D	ø8, Rc 1/8 G 1/8	ø10, Rc 1/4 G 1/4	ø10, Rc 1/4 G 1/4
ZH15D			
ZH18D			
ZH20D	ø12, Rc 3/8 G 3/8	ø12, Rc 3/8 G 3/8	ø12, Rc 3/8 G 3/8
ZH20D			

# Vacuum Ejector Box Type (Built-in Silencer)/Body Ported Type **ZH Series**

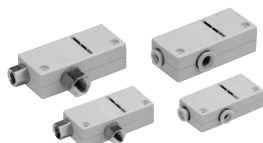

Box type: Type B



Body ported type: Type D

Ejector Symbol



Body ported type  
(Without silencer)  
ZH□□□B

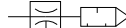

Box type  
(Built-in silencer)  
ZH□□□D

## Model

Model	Nozzle diameter (mm)	Body type	Max. vacuum pressure* (kPa)		Maximum suction flow rate (L/min (ANR))		Air consumption (L/min (ANR))	Connection (One-touch/Screw-in)			Weight (g)			
			Type S	Type L	Type S	Type L		Type S/Type L	SUP	VAC		EXH		
ZH05B□	0.5	Box type (Built-in silencer)	-88	-48	5	8	13	ø6, Rc 1/8 G 1/8	ø6, Rc 1/8 G 1/8	-	28			
ZH07B□	0.7				12	20	23				28			
ZH10B□	1.0				24	34	46				33			
ZH13B□	1.3	Box type (Built-in silencer)	-88	-48	40	70	78	ø8, Rc 1/8 G 1/8	ø10, Rc 1/4 G 1/4	-	66			
ZH05D□	0.5				5	8	13				ø6, Rc 1/8 G 1/8	ø6, Rc 1/8 G 1/8	ø6, Rc 1/8 G 1/8	11
ZH07D□	0.7				12	20	23							12
ZH10D□	1.0	24	34	46	ø6, Rc 1/8 G 1/8	ø6, Rc 1/8 G 1/8	ø8, Rc 1/8 G 1/8	16						
ZH13D□	1.3	40	70	78				ø8, Rc 1/8 G 1/8	ø10, Rc 1/4 G 1/4	ø10, Rc 1/4 G 1/4	27			
ZH15D□	1.5	55	75	95							ø10, Rc 1/4 G 1/4	ø12, Rc 3/8 G 3/8	ø12, Rc 3/8 G 3/8	43
ZH18D□	1.8	65	110	150	ø12, Rc 3/8 G 3/8	ø16, Rc 1/2 G 1/2	ø16, Rc 1/2 G 1/2							55
ZH20D□	2.0	85	135	185				95						

Fluid: Air, Operating temperature: 5 to 50 C, Max. operating pressure: 0.6 MPa, Standard supply pressure: 0.45 MPa

\* Supply pressure: 0.45 MPa.

## Construction

### Box type (Built-in silencer)

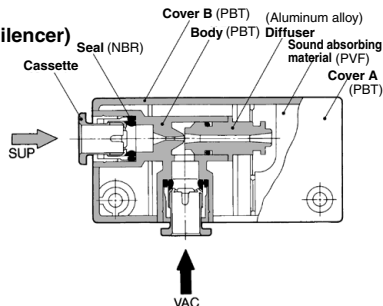

### Body ported (Without silencer)

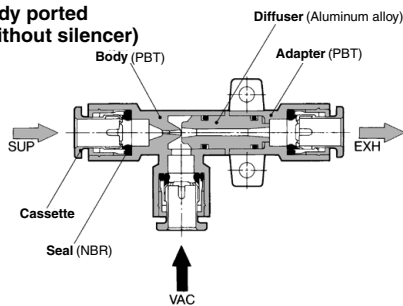

## ⚠ Precautions

- Be sure to read this before handling the products.
- Refer to back page 50 for Safety Instructions and pages 49 to 51 for Vacuum Equipment Precautions.

### ⚠ Caution

#### Mounting

Make sure that an excessive amount of load or moment is not applied to the ejector body due to pipe connections or installation.

#### Exhaust piping

On the ZH□□□□ models, keep exhaust ports open on at least one side. Make sure that the back pressure of the exhaust pipe on the ZH□□□□ models is 0.005 MPa or less. (Reference: Using tubing with an applicable diameter, its length must be 0.5 m or less.)

(Port indication: P: supply port; V: vacuum port; E: exhaust port.)

#### Selection and sizing

Refer to the vacuum equipment model selection on pages 25 to 48.



### Exhaust Characteristics/Flow Rate Characteristics

The flow rate characteristics correspond to a supply pressure of 0.45 MPa.

#### ZH15□S

##### Exhaust Characteristics

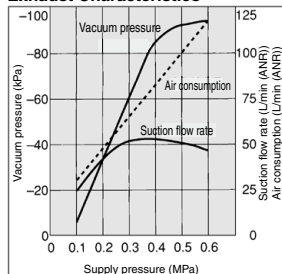

##### Flow Rate Characteristics

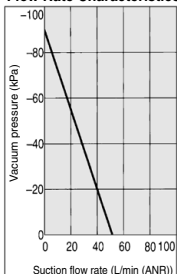

#### ZH15□L

##### Exhaust Characteristics

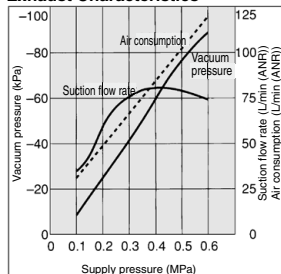

##### Flow Rate Characteristics

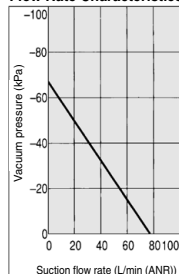

#### ZH18□S

##### Exhaust Characteristics

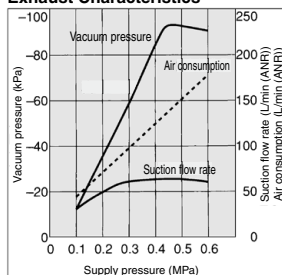

##### Flow Rate Characteristics

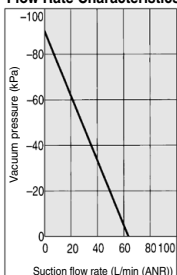

#### ZH18□L

##### Exhaust Characteristics

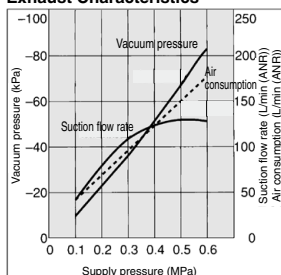

##### Flow Rate Characteristics

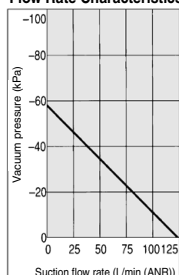

#### ZH20□S

##### Exhaust Characteristics

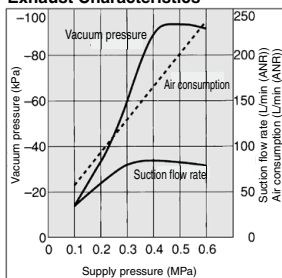

##### Flow Rate Characteristics

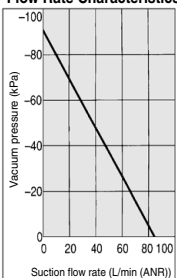

#### ZH20□L

##### Exhaust Characteristics

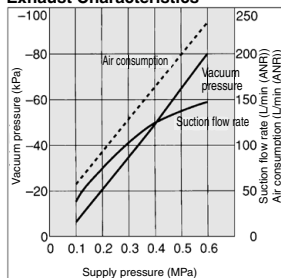

##### Flow Rate Characteristics

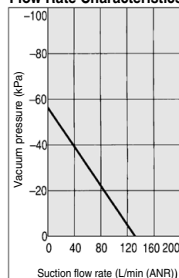

### How to Read Flow Rate Characteristics Graph

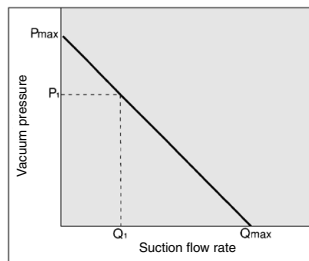

Flow rate characteristics are expressed in ejector vacuum pressure and suction flow. If suction flow rate changes, a change in vacuum pressure will also be expressed. Normally this relationship is expressed in ejector standard use.

In graph, Pmax is max. vacuum pressure and Qmax is max. suction flow. The valves are specified according to catalog use. Changes in vacuum pressure are expressed in the order below.

1. When ejector suction vport is covered and made airtight, suction flow becomes 0 and vacuum pressure is at maximum value (Pmax).
2. When suction port is opened gradually, air can flow through, (air leakage), suction flow

increases, but vacuum pressure decreases. (condition P1 and Q1)

3. When suction port is opened further, suction flow moves to maximum value (Qmax), but vacuum pressure is near 0. (atmospheric pressure).

When vacuum port (vacuum piping) has no leakage, vacuum pressure becomes maximum, and vacuum pressure decreases as leakage increases. When leakage value is the same as max. suction flow, vacuum pressure is near 0.

When ventirative or leaky work must be adsorbed, please note that vacuum pressure will not be high.

- ZK2
- ZQ
- ZR
- ZB
- ZA
- ZX
- ZM
- ZL
- ZH
- ZH-X267
- ZHP
- ZU
- VQD-V

## Box Type (Built-in silencer): ZH□BS□-□□

### One-touch connection

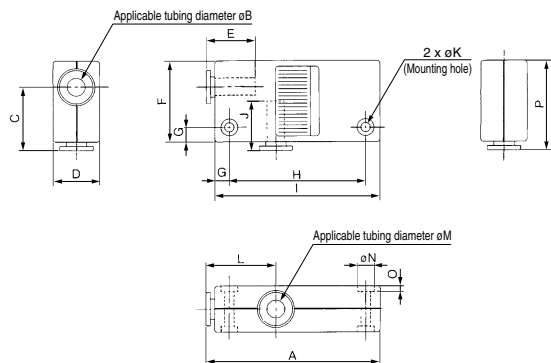

Model	A	øB	C	D	E	F	G	H
ZH05BS-06-06	60	6	22	16	16.8	28	5	47
ZH05BL-06-06								
ZH07BS-06-06								
ZH07BL-06-06								
ZH10BS-06-06	63	6	23	18	16.8	29	5	50
ZH10BL-06-06								
ZH13BS-08-10	78	8	27.5	23	18.7	35	7	61
ZH13BL-08-10								

Model	I	J	øK	L	øM	øN	O	P
ZH05BS-06-06	57	16.8	3.2	24	6	5.8	2	31
ZH05BL-06-06								
ZH07BS-06-06								
ZH07BL-06-06								
ZH10BS-06-06	60	16.8	3.2	26	6	5.8	2	32
ZH10BL-06-06								
ZH13BS-08-10	75	21	4.2	28	10	7.5	3	38.5
ZH13BL-08-10								

### One-touch and screw-in connection

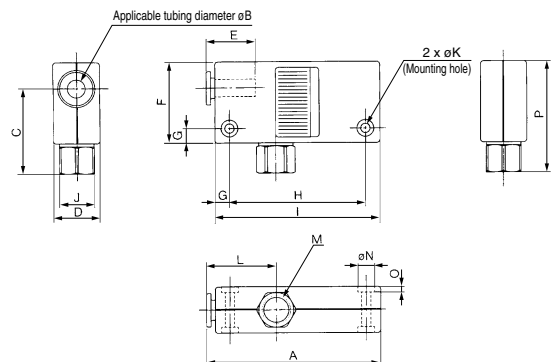

Model	A	øB	C	D	E	F	G	H
ZH05BS-06-01	60	6	29.5	16	16.8	28	5	47
ZH05BL-06-01								
ZH07BS-06-01								
ZH07BL-06-01								
ZH10BS-06-01	63	6	30.5	18	16.8	29	5	50
ZH10BL-06-01								
ZH13BS-08-02	78	8	38.5	23	18.7	35	7	61
ZH13BL-08-02								
ZH05BS-06-F01	60	6	29.5	16	16.8	28	5	47
ZH05BL-06-F01								
ZH07BS-06-F01								
ZH07BL-06-F01								
ZH10BS-06-F01	63	6	30.5	18	16.8	29	5	50
ZH10BL-06-F01								
ZH13BS-08-F02	78	8	39	23	18.7	35	7	61
ZH13BL-08-F02								

Model	I	J	øK	L	M	øN	O	P
ZH05BS-06-01	57	12	3.2	24	Rc 1/8	5.8	2	38.5
ZH05BL-06-01								
ZH07BS-06-01								
ZH07BL-06-01								
ZH10BS-06-01	60	12	3.2	26	Rc 1/8	5.8	2	39.5
ZH10BL-06-01								
ZH13BS-08-02	75	17	4.2	28	Rc 1/4	7.5	3	49.5
ZH13BL-08-02								
ZH05BS-06-F01	57	12	3.2	24	G 1/8	5.8	2	38.5
ZH05BL-06-F01								
ZH07BS-06-F01								
ZH07BL-06-F01								
ZH10BS-06-F01	60	12	3.2	26	G 1/8	5.8	2	39.5
ZH10BL-06-F01								
ZH13BS-08-F02	75	17	4.2	28	G 1/4	7.5	3	50
ZH13BL-08-F02								

• Contact SMC for combinations other than listed above.

**Box Type (Built-in silencer): ZH□B<sub>L</sub><sup>S</sup>-□-□**

**Screw-in connection**

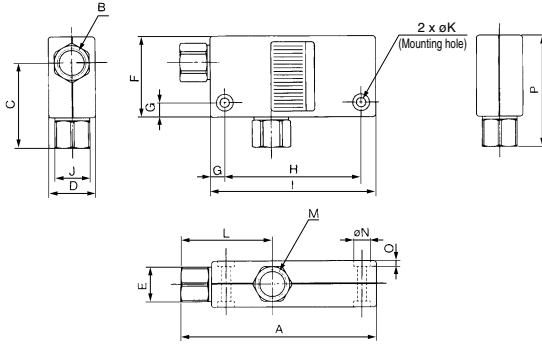

Model	A	B	C	D	E	F	G	H
ZH05BS-01-01								
ZH05BL-01-01	67.5	Rc 1/8	29.5	16	12	28	5	47
ZH07BS-01-01								
ZH07BL-01-01								
ZH10BS-01-01	70.5	Rc 1/8	30.5	18	12	29	5	50
ZH10BL-01-01								
ZH13BS-01-02	86.5	Rc 1/8	38.5	23	14	35	7	61
ZH13BL-01-02								
ZH05BS-F01-F01								
ZH05BL-F01-F01	67.5	G 1/8	29.5	16	12	28	5	47
ZH07BS-F01-F01								
ZH07BL-F01-F01								
ZH10BS-F01-F01	70.5	G 1/8	30.5	18	12	29	5	50
ZH10BL-F01-F01								
ZH13BS-F01-F02	86.3	G 1/8	39	23	14	35	7	61
ZH13BL-F01-F02								

Model	I	J	øK	L	M	øN	O	P
ZH05BS-01-01								
ZH05BL-01-01	57	12	3.2	31.5	Rc 1/8	5.8	2	38.5
ZH07BS-01-01								
ZH07BL-01-01								
ZH10BS-01-01	60	12	3.2	33.5	Rc 1/8	5.8	2	39.5
ZH10BL-01-01								
ZH13BS-01-02	75	17	4.2	36.3	Rc 1/4	7.5	3	49.5
ZH13BL-01-02								
ZH05BS-F01-F01								
ZH05BL-F01-F01	57	12	3.2	31.5	G 1/8	5.8	2	38.5
ZH07BS-F01-F01								
ZH07BL-F01-F01								
ZH10BS-F01-F01	60	12	3.2	33.5	G 1/8	5.8	2	39.5
ZH10BL-F01-F01								
ZH13BS-F01-F02	75	17	4.2	36.3	G 1/4	7.5	3	50
ZH13BL-F01-F02								

\* Please contact SMC for combinations other than listed above.

ZK2

ZQ

ZR

ZB

ZA

ZX

ZM

ZL

ZH

ZH

ZH-X267

ZHP

ZU

VQD-V

## Body Ported Type (Without silencer): ZH05D<sub>L</sub>-□-□-□, ZH15D<sub>L</sub>-□-□-□

### One-touch connection

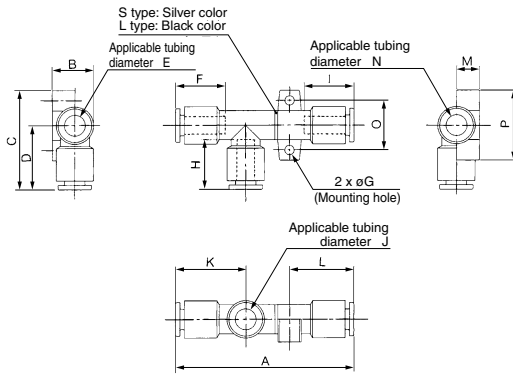

Model	A	B	C	D	øE	F	øG	H
ZH05DS-06-06-06	58.5	14.2	34	22	6	16.8	3.2	16.8
ZH05DL-06-06-06								
ZH07DS-06-06-06	61							
ZH07DL-06-06-06								
ZH10DS-06-06-08	66	17.2	37	23	6	16.8	4.2	16.8
ZH10DL-06-06-08								
ZH13DS-08-10-10	74.5	20	42.5	27.5	8	18.7	4.2	21.6
ZH13DL-08-10-10	79.5							
ZH15DS-10-12-12	93.3	22.5	47	29.5	10	21.6	4.2	21.8
ZH15DL-10-12-12								

Model	I	øJ	K	L	M	øN	O	P
ZH05DS-06-06-06	16.8	6	24	21	7.8	6	17	24
ZH05DL-06-06-06				22				
ZH07DS-06-06-06	18.7	6	26	24.5	9.6	8	20	28
ZH07DL-06-06-06				27				
ZH10DS-06-06-08	21.6	10	28	27	10.7	10	22	30
ZH10DL-06-06-08				27				
ZH13DS-08-10-10	21.6	12	31.5	33	12	12	27	35
ZH13DL-08-10-10				33				
ZH15DS-10-12-12	21.6	12	31.5	33	12	12	27	35
ZH15DL-10-12-12				33				

### One-touch and screw-in connection

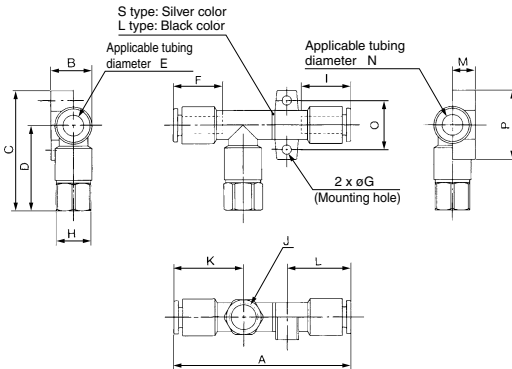

Model	A	B	C	D	øE	F	øG	H
ZH05DS-06-01-06	58.5	14.2	41.5	29.5	6	16.8	3.2	12
ZH05DL-06-01-06								
ZH07DS-06-01-06	61							
ZH07DL-06-01-06								
ZH10DS-06-01-08	66	17.2	44.5	30.5	6	16.8	4.2	12
ZH10DL-06-01-08								
ZH13DS-08-02-10	74.5	20	53.5	38.5	8	18.7	4.2	17
ZH13DL-08-02-10	79.5							
ZH15DS-10-03-12	93.3	22.5	58.5	41	10	21.6	4.2	19
ZH15DL-10-03-12								
ZH05DS-06-F01-06	58.5	14.2	41.5	29.5	6	16.8	3.2	12
ZH05DL-06-F01-06								
ZH07DS-06-F01-06	61							
ZH07DL-06-F01-06								
ZH10DS-06-F01-08	66	17.2	44.5	30.5	6	16.8	4.2	12
ZH10DL-06-F01-08								
ZH13DS-08-F02-10	74.5	20	54	39	8	18.7	4.2	17
ZH13DL-08-F02-10	79.5							
ZH15DS-10-F03-12	93.3	22.5	58.5	41	10	21.6	4.2	19
ZH15DL-10-F03-12								

Model	I	J	K	L	M	øN	O	P
ZH05DS-06-01-06	16.8	Rc 1/8	24	21	7.8	6	17	24
ZH05DL-06-01-06				22				
ZH07DS-06-01-06	18.7	Rc 1/8	26	24.5	9.6	8	20	28
ZH07DL-06-01-06				27				
ZH10DS-06-01-08	21.6	Rc 1/4	28	27	10.7	10	22	30
ZH10DL-06-01-08				27				
ZH13DS-08-02-10	21.6	Rc 3/8	31.5	33	12	12	27	35
ZH13DL-08-02-10				33				
ZH15DS-10-03-12	21.6	G 3/8	24	21	7.8	6	17	24
ZH15DL-10-03-12				22				
ZH05DS-06-F01-06	16.8	G 1/8	24	21	7.8	6	17	24
ZH05DL-06-F01-06				22				
ZH07DS-06-F01-06	18.7	G 1/8	26	24.5	9.6	8	20	28
ZH07DL-06-F01-06				27				
ZH10DS-06-F01-08	21.6	G 1/4	28	27	10.7	10	22	30
ZH10DL-06-F01-08				27				
ZH13DS-08-F02-10	21.6	G 3/8	31.5	32.8	12	12	27	35
ZH13DL-08-F02-10				32.8				
ZH15DS-10-F03-12	21.6	G 3/8	31.5	32.8	12	12	27	35
ZH15DL-10-F03-12				32.8				

\* Please contact SMC for combinations other than listed above.

**Body Ported Type (Without silencer): ZH05D<sup>S</sup>-□-□-□, ZH15D<sup>S</sup>-□-□-□**

**Screw-in connection**

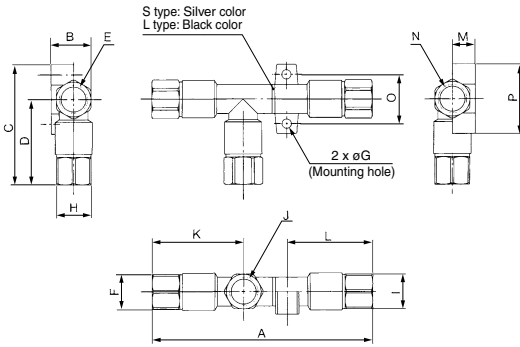

Model	A	B	C	D	E	F	øG	H
ZH05DS-01-01-01	73.5	14.2	41.5	29.5	Rc 1/8	12	3.2	12
ZH05DL-01-01-01								
ZH07DS-01-01-01	76							
ZH07DL-01-01-01								
ZH10DS-01-01-01	81.8	17.2	44.5	30.5	Rc 1/8	12	4.2	12
ZH10DL-01-01-01								
ZH13DS-01-02-02	93.8	20	53.5	38.5	Rc 1/8	14	4.2	17
ZH13DL-01-02-02								
ZH15DS-02-03-03	116.5	22.5	58.5	41	Rc 1/4	17	4.2	19
ZH15DL-02-03-03								
ZH05DS-F01-F01-F01	73.5	14.2	41.5	29.5	G 1/8	12	3.2	12
ZH07DS-F01-F01-F01								
ZH07DL-F01-F01-F01	76							
ZH10DS-F01-F01-F01								
ZH10DL-F01-F01-F01	81.8	17.2	44.5	30.5	G 1/8	12	4.2	12
ZH13DS-F01-F02-F02								
ZH13DL-F01-F02-F02	94.3	20	54	39	G 1/8	14	4.2	17
ZH15DS-F02-F03-F03								
ZH15DL-F02-F03-F03	116.5	22.5	58.5	41	G 1/4	17	4.2	19
ZH15DL-F02-F03-F03								

Model	I	J	K	L	M	N	O	P
ZH05DS-01-01-01	12	Rc 1/8	31.5	28.5	7.8	Rc 1/8	17	24
ZH05DL-01-01-01				29.5				
ZH07DS-01-01-01	14	Rc 1/8	33.5	32.8	9.6	Rc 1/8	20	28
ZH07DL-01-01-01								
ZH10DS-01-01-01	17	Rc 1/4	36.3	38	10.7	Rc 1/4	22	30
ZH10DL-01-01-01								
ZH13DS-01-02-02	19	Rc 3/8	43	44.5	12	Rc 3/8	27	35
ZH13DL-01-02-02								
ZH15DS-02-03-03	12	G 1/8	31.5	28.5	7.8	G 1/8	17	24
ZH05DL-F01-F01-F01				29.5				
ZH07DS-F01-F01-F01	14	G 1/8	33.5	32.8	9.6	G 1/8	20	28
ZH07DL-F01-F01-F01								
ZH10DS-F01-F01-F01	17	G 1/4	36.3	38.5	10.7	G 1/4	22	30
ZH10DL-F01-F01-F01								
ZH13DS-F01-F02-F02	19	G 3/8	43	44.5	12	G 3/8	27	35
ZH13DL-F01-F02-F02								
ZH15DS-F02-F03-F03	12	G 1/8	31.5	28.5	7.8	G 1/8	17	24
ZH15DL-F02-F03-F03				29.5				

\* Please contact SMC for combinations other than listed above.

ZK2

ZQ

ZR

ZB

ZA

ZX

ZM

ZL

ZH

ZH

ZH-X267

ZHP

ZU

VQD-V

# ZH Series

## Body Ported Type (Without silencer): ZH18D<sub>L</sub>-□-□-□, ZH20D<sub>L</sub>-□-□-□

### One-touch connection

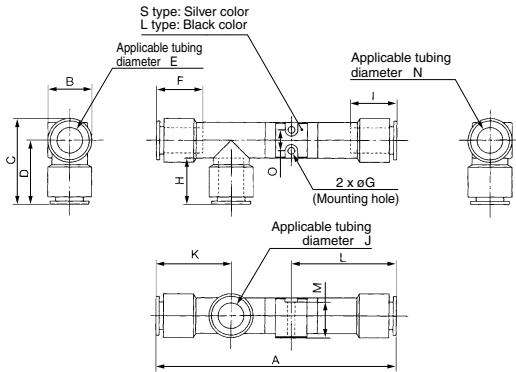

Model	A	B	C	D	øE	F	øG	H
ZH18DS-12-12-12	114	21	41	30.5	ø12	21.8	ø3.5	21.8
ZH18DL-12-12-12								
ZH20DS-12-16-16	124.6	26.8	46	35.5	ø12	21.8	ø3.5	24.2
ZH20DL-12-16-16								

Model	I	øJ	K	L	M	øN	O
ZH18DS-12-12-12	21.8	ø12	35.5	50	17	ø12	10
ZH18DL-12-12-12							
ZH20DS-12-16-16	24.2	ø16	38.5	54.3	22	ø16	12
ZH20DL-12-16-16							

### One-touch and screw-in connection

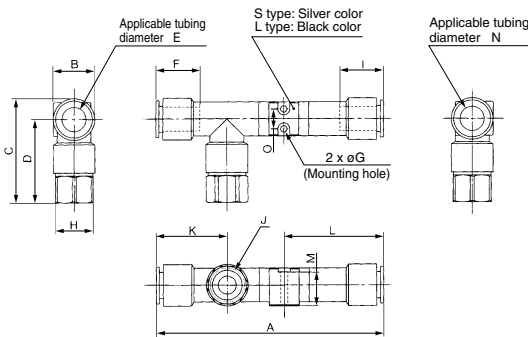

Model	A	B	C	D	øE	F	øG	H
ZH18DS-12-03-12	114	21	52.5	42	ø12	21.8	ø3.5	19
ZH18DL-12-03-12								
ZH20DS-12-04-16	124.6	26.8	61	50.5	ø12	21.8	ø3.5	24
ZH20DL-12-04-16								
ZH18DS-12-F03-12	114	21	52.5	42	ø12	21.8	ø3.5	19
ZH18DL-12-F03-12								
ZH20DS-12-F04-16	124.6	26.8	67	56.5	ø12	21.8	ø3.5	24
ZH20DL-12-F04-16								

Model	I	J	K	L	M	øN	O
ZH18DS-12-03-12	21.8	Rc 3/8	35.5	50	17	ø12	10
ZH18DL-12-03-12							
ZH20DS-12-04-16	24.2	Rc 1/2	38.5	54.3	22	ø16	12
ZH20DL-12-04-16							
ZH18DS-12-F03-12	21.8	G 3/8	35.5	50	17	ø12	10
ZH18DL-12-F03-12							
ZH20DS-12-F04-16	24.2	G 1/2	38.5	54.3	22	ø16	12
ZH20DL-12-F04-16							

### Screw-in connection

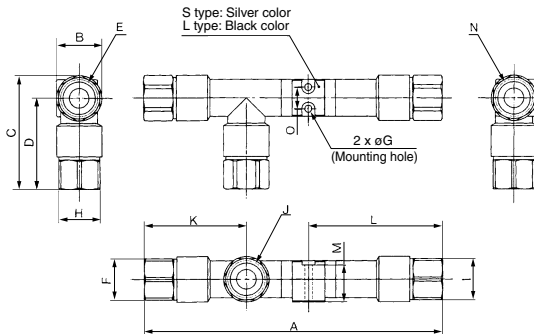

Model	A	B	C	D	E	F	øG	H
ZH18DS-03-03-03	137	21	52.5	42	Rc 3/8	19	ø3.5	19
ZH18DL-03-03-03								
ZH20DS-03-04-04	151.1	26.8	61	50.5	Rc 3/8	19	ø3.5	24
ZH20DL-03-04-04								
ZH18DS-F03-F03-F03	137	21	52.5	42	G 3/8	19	ø3.5	19
ZH18DL-F03-F03-F03								
ZH20DS-F03-F04-F04	157.1	26.8	67	56.5	G 3/8	19	ø3.5	24
ZH20DL-F03-F04-F04								

Model	I	J	K	L	M	N	O
ZH18DS-03-03-03	19	Rc 3/8	47	61.5	17	Rc 3/8	10
ZH18DL-03-03-03							
ZH20DS-03-04-04	24	Rc 1/2	50	69.3	22	Rc 1/2	12
ZH20DL-03-04-04							
ZH18DS-F03-F03-F03	19	G 3/8	47	61.5	17	G 3/8	10
ZH18DL-F03-F03-F03							
ZH20DS-F03-F04-F04	24	G 1/2	50	75.3	22	G 1/2	12
ZH20DL-F03-F04-F04							

\* Please contact SMC for combinations other than listed above.

Example of Application Circuit

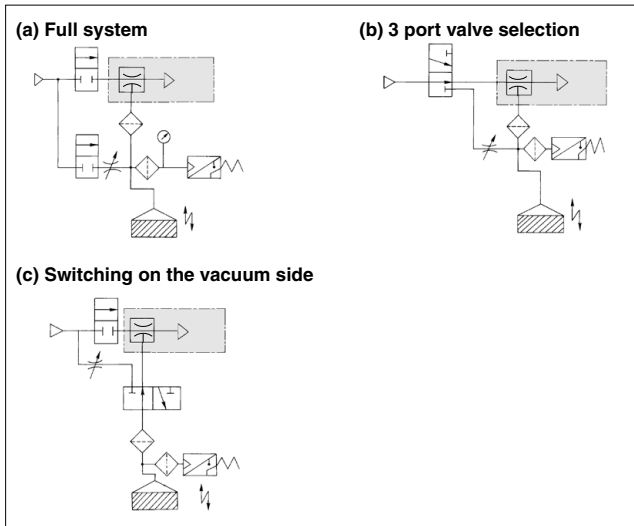
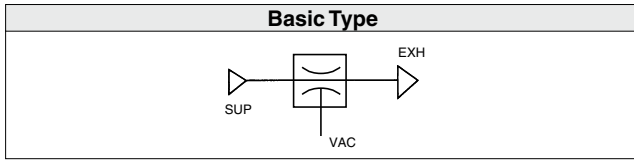

Diagrams (a) to (c) show the combination with peripherals.

**⚠ Caution**

**Handling of application circuits**

**1. Countermeasures for power outages**  
Select a supply valve for the ejector that is normally open or one that is equipped with a self-holding function.

**2. Using a small-diameter picking nozzle**  
For picking electronic parts or small precision parts, if the picking nozzle is approximately  $\phi 1$  mm in diameter, the vacuum remains high by being restricted by the nozzle. As a result, it will not be possible to verify it with the vacuum switch. In such a case, it is necessary to use an ejector that is suited to the nozzle and to select a vacuum switch with a favorable hysteresis and precision.

**3. Considerable leakage from the suction surface**

If a workpiece is made of porous material or if there is air leakage from the area between the pad and the workpiece, use a nozzle with a large diameter and a large suction flow volume.

If the amount of leakage is known based on the effective sectional area of the side with the leakage, the vacuum pressure can be estimated in accordance with the ejector's flow volume characteristics.

**4. Suction filter**

To protect the ejectors and valves from dust, the use of a suction filter (ZFA, ZFB, ZFC series) is recommended.

**5. Use of a vacuum switch**

It is recommended that verification be made with a vacuum switch as much as possible.

**6. Vacuum release valve**

To serve as a vacuum release valve, use a 2 port or 3 port valve that can be used under vacuum condition. For 3 port valves, the exhaust port should be plugged. In addition, add a needle valve that can regulate the flow volume of the vacuum releasing air. Use the atmospheric pressure or a positive pressure for the vacuum releasing pressure.

**7. Common exhaust**

For common exhaust as shown below, use an exhaust pipe big enough to prevent exhaust resistance.

**Exhaust pipe with enough capability**

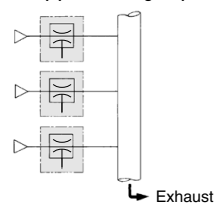

ZK2
ZQ
ZR
ZB
ZA
ZX
ZM
ZL
ZH
ZH
ZH-X267
ZHP
ZU
VQD-V