

PowerLogic™

Electrical network management

Energy management, revenue metering
and power quality monitoring



www.se.com/uk

Life Is On

Schneider
Electric

Contents

Introduction to PowerLogic	3
Product panorama	9
Basic energy metering IEM2000 series and IEM3000 series	14
Basic multi-function metering PM3000 series and PM5000 series	30
Advanced metering PM8000 series and ION9000 series	48
Advanced utility metering ION8800	72
Multi-circuit metering BCPM	84
Communications and gateways Link150, Com'X 210, Com'X 510 and ION7550 RTU	100
Energy & power management software EcoStruxure™ Power Monitoring Expert, EcoStruxure™ Power SCADA Operation	128
Current transformers	140
Commercial reference numbers	152

Clicking on a
Commercial Reference Number
or scanning the product's
QR Code
links you to further product information on
www.se.com/uk/en/

PowerLogic™ System is...

Schneider Electric believes every business can increase productivity while consuming less and achieving energy savings of 10% to 30%.

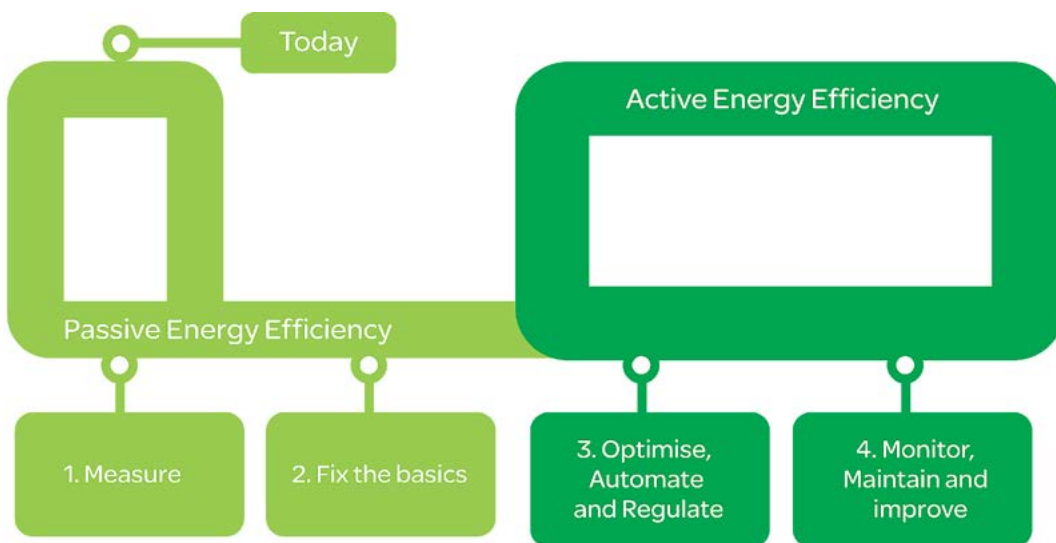

Saving energy reduces costs and pollution, but you need the tools to uncover all opportunities, avoid risks, track progress against goals, and verify success. Schneider Electric provides these tools via the world's most advanced energy intelligence technology: PowerLogic.

A PowerLogic system of meters, software and power quality solutions help manage all energy assets, every second of the day. A PowerLogic system enables all stakeholders, from CEO to facility and engineering managers, to respond quickly to potential problems and manage energy in financial and environmental terms.

PowerLogic technology delivers the key performance indicators and analytics that you need to strategically balance emissions, efficiency, reliability and cost.

PowerLogic technology forms one part of your total energy management solution from Schneider Electric. As the global energy management specialist, we offer end-to-end power, building and process management solutions that help you optimize energy use and costs, improve performance, enhance comfort and safety, and deliver uninterrupted service while taking responsible care of our planet.

Our expert services can help you audit your energy use and build your energy action plan. From power factor correction systems, harmonic filtering and variable speed drives to HVAC and lighting controls, we offer a complete range of energy efficient technologies.

Gain energy insight and control with PowerLogic™ systems

Cutting-edge technology to increase profitability

PowerLogic technology converts the complex dynamics governing the relationship between power generation and distribution on the utility side, and energy consumption, cost and reliability on the consumer side, into timely, easily understood information. Businesses can use this powerful to improve tactical actions and strategic decision making.

From a single facility to an entire enterprise, PowerLogic meters monitor key distribution points 24 hours a day. Whether from generators, substations, service entrances, mains, feeders, loads or 3rd party equipment and systems, PowerLogic technology tracks, records and reports all real-time conditions and historical performance data. Intuitive web-based interfaces give stakeholders access to this data as well as advanced analytics, alarm annunciation and control capabilities. It supports comprehensive energy management programs by tracking performance and empowering you to make effective decisions.

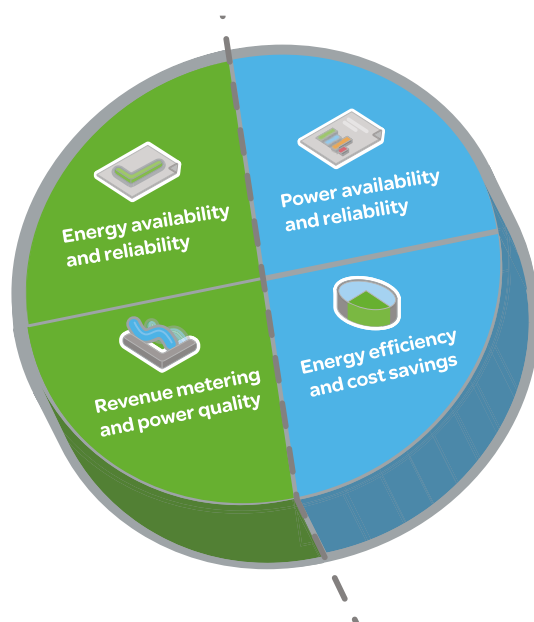

Supply

Energy availability and reliability

- Improve T&D network reliability
- Enhance substation automation
- Maximize the use of your existing infrastructure

Revenue metering and power quality

- Maximize metering accuracy at all interchange points
- Verify compliance with new power quality standards
- Analyse and isolate the source of power quality problems

Demand

Power availability and reliability

- Validate that power quality complies with the energy contract
- Identify power quality issues and fix them quickly with reliable mitigation solutions
- Improve response to power-related problems
- Leverage existing infrastructure capacity and avoid over-building
- Support proactive maintenance to prolong asset life

Energy efficiency and cost savings

- Measure efficiency, reveal opportunities and verify savings
- Manage greenhouse gas emissions
- Allocate energy costs to departments or processes
- Reduce peak demand and power factor penalties
- Enable participation in loadcurtailment programs (e.g. demand response)
- Strengthen rate negotiation with energy suppliers
- Identify billing discrepancies
- Sub-bill tenants for energy costs

Market segments



Industry

From finance to engineering, PowerLogic technology gives industry professionals the energy intelligence and control they need to support strategic decisions and establish best energy practices. It will help you reduce operational costs and meet new emissions standards without compromising production schedules or product quality.

Key points are monitored throughout your power distribution, building and backup systems. Enterprise-level software helps you maximize the use of your existing energy assets, increase energy efficiency and avoid demand or power factor penalties. Use it to uncover and solve hidden power problems that can shorten equipment life or cause costly downtime.

- Cost allocation
- Procurement optimization
- Power factor correction
- Continuity of service even in case of an earth fault

Buildings

Building managers through operations staff can cut energy and maintenance costs without effecting the comfort or productivity of their tenants, employees, students, patients or customers. A PowerLogic system will track all utilities and equipment conditions, and enterprise-level software will help you analyse and improve electrical reliability.

You can forecast energy requirements, optimize multi-site contracts and accurately allocate or sub-bill costs. Key performance indicators help you find and sustain energy savings, reduce emissions and meet “green” building standards in order to increase asset value and attract or retain tenants..

- Tenant sub-billing
- Cost allocation
- Energy efficiency & benchmarking
- Procurement optimization
- Power availability
- Demand response / load curtailment



Utilities

Today's energy market is more complex than ever before. Whether you generate, transmit or distribute electricity, more stakeholders need shared access to timely, accurate energy data from more exchange points and you need to maintain power availability and reduce price volatility in the face of rising demand and transmission congestion. A PowerLogic energy information system helps you meet all of these challenges by:

- Metering all key interchange points with the highest possible accuracy
- Improving the quality of power delivered to your customers
- Ensuring the reliability and efficiency of your network and equipment

From advanced energy and power quality metering systems to enterprise-level analytic software and power quality mitigation solutions, PowerLogic systems deliver business-critical information that conventional metering, SCADA and billing systems cannot. It gives you the energy intelligence and control needed to track performance, stay informed of critical conditions and empower you to make strategic decisions. It will help you increase reliability, maximize the use of resources and improve service.

- Revenue metering
- Power quality monitoring
- Power availability and reliability
- Insulation monitoring

Critical infrastructure

PowerLogic technology helps keep your systems operating continuously and securely with an economical supply of energy. Whether you manage data, communication, transportation or environmental services, minimising the risk of power-related downtime and keeping costs under control is a priority.

A PowerLogic system monitors all power and cooling systems, accurately tracks their energy consumption, and allows you to identify and fix power quality issues as soon as they arise. Enterprise-level software delivers insightful diagnostics and metrics to help verify the reliability of your backup systems and maximize the use of existing capacity to defer new capital investments. You can also reveal energy inefficiencies and strengthen energy procurement across multiple sites.

- Infrastructure optimization
- Power quality analysis compliance
- Alarming and event notification
- Energy efficiency
- Cost allocation
- Procurement optimization





Panorama of the PowerLogic™ range

Whatever the size or type of application, this proven PowerLogic™ product line is a reliable and an integral part of any energy management and power monitoring system.

Use this panorama to select the most efficient products for your application needs.

Panorama of the PowerLogic range

Basic energy metering



Name	iEM2000/iEM2010/ iEM2000T/iEM2100	iEM3000 Series	PM3000 Series
Function	kilowatt-hour meters	kilowatt-hour meters	metering & sub-metering Class 0.5S IEC 62053-22 Class 1 IEC 62053-21 Class 2 IEC 62053-23

Applications

Panel instrumentation

Panel instrumentation	E	I, U, F, P, Q, S, PF, E (Power demand and current demand)	I, U, F, P, Q, S, PF, E (Power demand and current demand)
-----------------------	---	--	--

Energy efficiency & cost

Sub-billing & cost allocation			✓
Demand & load management			
Billing analysis			

Power availability & reliability

Compliance monitoring			
Dip/swell, transient			
Harmonics			

Revenue metering

Revenue meter			
---------------	--	--	--

Characteristics

Measurement accuracy	Class 0.5S / Class 1	Class 0.5S / Class 1	Class 0.5
Installation	DIN rail 1, 2, 5, or 7 x 18 mm modules	DIN rail	DIN rail
Voltage measurement	400 V AC direct	50 V to 330 V (Ph-N) 80 V to 570 V (Ph-Ph) up to 1MV AC (ext VT)	50 V to 330 V AC (Ph-N) 80 V to 570 V AC (Ph-Ph) up to 1MV AC (ext VT)
Current measurement	40 to 125 A direct or external CT	external CT	external CT
Communication ports		1	1
Inputs / Outputs		2 I/O	2 I/O
Memory capacity			

	page 19	page 23	page 32
Link to:	MORE	MORE	MORE

Panorama of the PowerLogic range (cont'd)

Basic multi-function (cont'd) Advanced metering



Name	PM5000 Series	PM8000 Series	ION9000
Function	metering & sub-metering Class 0.5S IEC 62053-22 Class 0.2S (PM55xx) IEC 62053-22 Class 1/2 IEC 62053-24 IEC 61557-12	energy & basic power quality meter IEC 62053-22 Class 0.2S ANSI C12.20 Class 0.2 IEC 61000-4-30 Class S IEC 62586-2 IEC 61557-12 PMD/Sx/K70/0.2 IEC / UL 61010-1	energy & advanced power quality meter IEC 62053-22 Class 0.1S ANSI C12.20 Class 0.1 IEC 61000-4-30 Class A IEC 62586-1 / -2 IEC 61557-12 PMD/Sx/K70/0.2 IEC / UL 61010-1

Applications

Panel instrumentation

Panel instrumentation	I, U, F, P, Q, S, PF, E (Power demand and current demand)	I, U, F, P, Q, S, PF, E, THD, Min/Max, harm, alarm, I/O (I, U unbalance, demand, clock/cal, dip/swell)	I, U, F, P, Q, S, PF, E, THD, Min/Max, harm, alarm, I/O (I, U unbalance, demand, clock/cal, dip/swell, transients, flicker, RVC, mains signalling, 1/2 cycle RMS)
-----------------------	--	--	---

Energy efficiency and cost

Sub-billing and cost allocation	✓	✓	✓
Demand and load management		✓	✓
Billing analysis		✓	✓

Power availability & reliability

Harmonics	✓	✓	✓
Dip/swell, transient		dip/swell	✓
Compliance monitoring	✓	✓	✓

Revenue metering

Revenue metering			
------------------	--	--	--

Characteristics

Measurement accuracy (active energy)	Class 0.2S (PM55xx) Class 0.5S	IEC 62053-22 Class 0.2S ANSI C12.20 Class 0.2	IEC 62053-22 Class 0.1S ANSI C12.20 Class 0.1
Installation	Flush & DIN 96 mm x 96 mm	Flush & DIN 96 mm x 96 mm	Flush & DIN 160 mm x 160 mm Display 96 mm or 197 mm x 175 mm
Voltage measurement	20-400 V L-N 20-690 V L-L (PM55xx) 20-277 V L-N 35-690 V L-L (PM51/53xx)	57-400 V AC L-N 3P (100-690 V AC L-L)	57-400 V L-N AC or 100-690 V L-L AC
Current measurement	external CT	external CT	external CT
Communication ports	2	3	4
Inputs / Outputs	1DO for PM51xx 4/6 I/O PM53xx based on model 6 I/O for PM55xx	up to 27 DI, 9 DO up to 16 AI, 8 AO	up to 32 DI, 4 DO, 10 RO (relay) up to 16 AI, 8 AO
Memory capacity	256 kb 1.1 MB (PM55xx)	512 MB	2 GB

	page 38	page 50	page 60
Link to:	MORE	MORE	MORE

Panorama of the PowerLogic range (cont'd)

Advanced metering

Multi-circuit metering



Name	ION8800	BCPM
Function	energy & power quality meter IEC 62052-11 IEC 62053-22/23 Class 0.2S IEC 61000-4-30	branch circuit monitor IEC 61036 Class 1

Applications

Panel instrumentation

Panel instrumentation	I, U, F, P, Q, S, PF, E (demand, minimum and maximum values)	I, U, F, P, Q, S, PF, E (Power demand and current demand)
-----------------------	--	---

Energy efficiency & cost

Sub-billing and cost allocation	✓	✓	✓	✓
Demand and load management	✓	✓	✓	
Billing analysis	✓	✓	✓	

Power availability & reliability

Harmonics	✓	✓	✓	
Dip/swell, transient	✓	✓	✓	
Compliance monitoring	✓	✓	✓	

Revenue metering

Revenue metering	✓	✓	✓	
------------------	---	---	---	--

Characteristics

Measurement accuracy (active energy)	Class 0.2S	Class 1 (mains active energy)
Installation	DIN 43862 rack	Panel or enclosure
Voltage measurement	57-288 V L-N AC or 99-500 V L-L AC	90 – 277 V L-N voltage Inputs
Current measurement	external CT	CT strips for branch circuits and external CTs for mains
Communication ports	5	1 for main
Inputs / Outputs	up to 16 I/O	
Memory capacity	up to 10 MB	

page 74

page 86

Link to:

[MORE](#)

[MORE](#)

Panorama of the PowerLogic range (cont'd)

Communications & gateways

Monitoring software

Current transformers



Name	Link150	Com'X 210 Com'X 510	ION7550 RTU	EcoStruxure™ Energy & power management software	CTs Ip / 5 A
Function	Modbus Serial to Modbus TCP/IP protocol gateway	Modbus gateway plus Energy Server and Cloud connector	Ethernet gateway-server + onboard I/O	Power management, network protection and control	current transformer

Features

RS-485 / Ethernet gateway	Ethernet Gateway	Ethernet Gateway	✓	EcoStruxure™ Power Monitoring Expert, EcoStruxure™ Power SCADA Operation 100+ Schneider Electric devices
Devices supported	All Modbus devices	100+ known Schneider Electric devices and the ability to create custom Modbus models. EM3000 Series, iEM3000 Series, Acti9 Smartlink Masterpact, PM5000 Series, Compact NSX, iEM1, iEM2000 series, PM3000 Series, PM5350, PM5000, PM8000, ION9000, CM4000	ION8800, ION9000, Modbus devices PM5350 PM5000 PM8000	
Web server with standard HTML pages	Configuration only	Com'X 510 - full support Com'X 210 - config. only	✓	
Web server with custom HTML pages		Custom web page support		
Real time data	✓	Available on Com'X 510	✓	
Historical data	✓	Com'X 510 onboard storage Com'X 210 - publish to database server		
Automatic notification		Event Notification to FI	✓	
Alarm and event logs			✓	
Waveform display			RTU includes alarm and event logs	
Custom animated graphics				
Manual/automatic reports		✓		

Installation

- b insulated cable, diameter 21 to 35 mm, through transformer
- b busbar through transformer
- b cable connections

Characteristics

Ethernet ports Modbus TCP/IP protocol	2 (switch mode only)	2	10/100 Base TX port	EcoStruxure™ is an architecture of interoperable, and scalable supervisory software dedicated to power monitoring that enables you to maximize operational efficiency, optimize power distribution systems, and improve bottom-line performance.	b transformation ratio: 40/5 A to 6000/5 A b accuracy: class 0.5 to 3 b maximum rated operational voltage: 720 V AC b tropicalised
RS-485 (2-wire / 4-wire) ports, Modbus protocol	2w/4w - 1 (rj45)	1	3		
Number of devices connected directly	32	64 devices/32 max Modbus, 2 analog sensors	64		
RS-232 configuration ports	1		1		
Miscellaneous	Serial line to Ethernet connectivity - serial or Ethernet master	Connectivity: WiFi, Ethernet, Zigbee, GPRS, + 3G	modem port I/O (20 I / 12 O)		
Installation	9 DIN rail	DIN rail	DIN 192 cutout 186 x 186 mm		

Link to:	page 105 MORE	page 109 MORE	page 119 MORE	page 130 PME SCADA	page 141 MORE
-----------------	--------------------------------	--------------------------------	--------------------------------	-------------------------------------	--------------------------------

Basic energy metering



Overview

Whether you require a single-phase kWh meters or full-featured, dual tariff energy meter, Schneider Electric provides iEM2xxx & iEM3xxx series meters to best fit your customer's application.

- PowerLogic iEM2000 series
- PowerLogic iEM2100 series
- PowerLogic iEM3000 series



[> Basic energy metering](#)

Acti9 iEM2000 Series

Technical Datasheet

The Acti9 iEM2000 series energy meters offer a cost-attractive, competitive range of single-phase DIN rail-mounted energy meters ideal for sub-billing and cost allocation applications.

Applications

- Monitor power consumption for each floor, office sector, or unit
- Allocate energy costs to lower cost of operations, optimise your building's power efficiency
- Connect to power management software to take full advantage of the IoT digital power installation

PB105289



[> Acti9 iEM2000 Series](#)

The solution for:

All markets that can benefit from a solution that includes PowerLogic iEM2000 series meters:

- Buildings
- Industry
- Data Centre & networks
- Infrastructures (airport, road tunnels, telecom).

Benefits

The Acti9 iEM2000 series meters are economical and easy to install in panelboards and switchboards:

- DIN rail mounted, compact size
- Accurate data measurement with Class 1 accuracy

Advantages

- Active energy Class 1 accuracy, with LCD display
- Modbus RS-485 and pulse output
- Direct connect, self-powered
- MID approved
- Two tariffs

Energy management system:

To get the most effective use from your Schneider Electric measurement and metering devices, we offer a range of dedicated data loggers and gateways for your building energy management.

Conformity of standards

- IEC 62053-21
- EN 50470-3

iEM2000 feature selection

	iEM2000T	iEM2000	iEM2010	iEM2050	iEM2055
Self-powered	■	■	■	■	■
Display		■	■	■ (6 digit LCD)	■ (6 digit LCD)
Width (mm)	18	18	18	17.5	17.5
Current input	40 A	40 A	40 A	45 A	45 A
Multi-tariff				2 tariffs	2 tariffs
Communication				Modbus	Modbus
Active Energy accuracy	Class 1 IEC 62053-21	Class 1 IEC 62053-21 Class B EN 50470-3	Class 1 IEC 62053-21 Class B EN 50470-3	Class 1 IEC 62053-21	Class 1 IEC 62053-21 Class B EN 50470-3
Digital outputs	1 P/O		1 P/O	1 P/O	1 P/O
MID for billing application		■	■		■
Commercial reference number	A9MEM2000T	A9MEM2000	A9MEM2010	A9MEM2050	A9MEM2055

See your Schneider Electric representative for complete ordering information.

iEM2000 series technical specifications

Technical specifications

	iEM2000T	iEM2000	iEM2010	iEM2050	iEM2055
COMM reference number	A9MEM2000T	A9MEM2000	A9MEM2010	A9MEM2050	A9MEM2055
Direct connection	Up to 40 A	Up to 40 A	Up to 40 A	Up to 45 A	Up to 45 A
Pulse output operation	100 pulses/kwh (120ms long)			10000, 2000, 1000, 100, 10, 1, 0.1, 0.01 pulses/kWh	
Display capacity	999999.9 kWh			9999.99 kWh (switching to 99999.9 when over this value)	
Voltage range (L-N)	184 to 276 V AC			195 to 253 V AC	
Operating frequency	50/60 Hz			50 Hz	
Meter constant LED	3200 flashes per kWh			10000 flashes per kWh	
Wiring capacity (Power)	4 mm ²			2.5 mm ²	
Wiring capacity (Communications)	10 mm ²			8-10 mm ²	
Consumption	<10 VA				
IP protection	IP40 front panel and IP20 casing			IP51 front panel	
Temperature	-10°C to 55°C			-25°C to 55°C	
Active energy	■	■	■	■	■
Reactive energy				■	■
Active power				■	■
Reactive power				■	■
Power Factor				■	■
Current and voltage				■	■
Frequency				■	■

iEM2050/iEM2055 dimensions

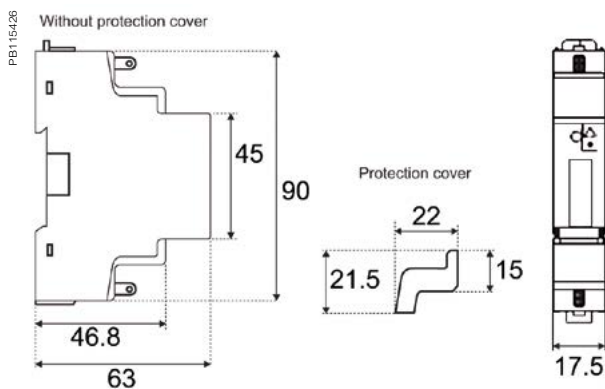

Maximum diameter power connection clamps 8 mm² (solid copper). See the appropriate product Installation Guide for complete instructions.

iEM2000 dimensions

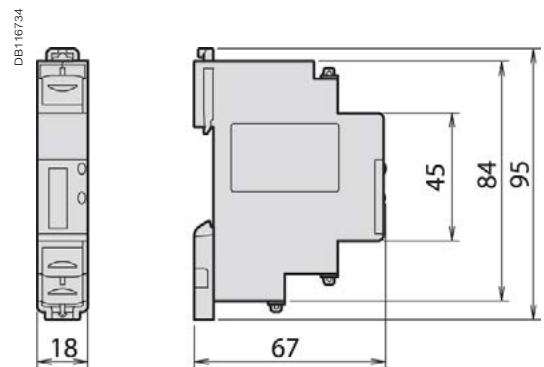

Maximum diameter power connection clamps 8 mm² (solid copper). See the appropriate product Installation Guide for complete instructions.

Acti9 iEM2100 Series

The Acti9 iEM2100 series energy meters are ideal for basic kWh metering and billing applications and support two protocols (Modbus and M-bus) that allow them to integrate seamlessly into your customers' existing networks.

Applications

- Monitor the power consumption of each sector, unit, workshop...
- Manage an electrical installation and optimise your building's power efficiency
- Various business, industrial and residential applications

PE119059



[> Acti9 iEM2100 Series](#)

The solution for

All markets that can benefit from a solution that includes PowerLogic iEM2100 series meters:

- Buildings
- Industry
- Data Centre & networks
- Infrastructures (airport, road tunnels, telecom).

Benefits

The Acti9 iME kilowatt-hour meters are specially economic and easy to install in all switchboards.

Competitive advantages

- Compact size
- MID compliant (selected models) providing certified accuracy and data security
- Four quadrant measurement
- Electrical parameter measurement eg. V, I, P, PF
- Onboard Modbus or M-bus communication
- A complete range of energy meters
- Compatible with Acti9 range

Energy management system:

To get the most effective use from your Schneider Electric measurement and metering devices, we offer a range of dedicated data loggers and gateways for your building energy management.

Conformity of standards

- IEC 62052-11
- IEC 62053-21
- IEC 62053-23
- EN 50470-1
- EN 50470-3

iEM2100 feature selection

	iEM2100	iEM2105	iEM2110	iEM2135	IEM2150	iEM2155
Self-powered	■	■	■	■	■	■
Display	■	■	■	■	■	■
Width (mm)	36	36	36	36	36	36
Current input	63 A	63 A	63 A	63 A	63 A	63 A
Active Energy accuracy	Class 1	Class 1	Class 1	Class 1	Class 1	Class 1
Reactive Energy accuracy	Class 2	Class 2	Class 2	Class 2	Class 2	Class 2
Four quadrant Energy measurement			■	■	■	■
Multi-tariff			2	2		2
Digital inputs			1 (tariff switching)	1 (tariff switching)		1 (tariff switching)
Digital outputs		1 P/O	2 P/O's			
Communication protocol				M-bus	Modbus RS-485	Modbus RS-485
MID for billing application			■	■		■
Commercial reference number	A9MEM2100	A9MEM2105	A9MEM2110	A9MEM2135	A9MEM2150	A9MEM2155

Acti9 iEM2100 series technical specifications

Technical specifications						
	iEM2100	iEM2105	iEM2110	iEM2135	iEM2150	iEM2155
Direct connection	63 A	63 A	63 A	63 A	63 A	63 A
Pulse output operation		1 pulse/kwh (200ms long)	1 to 1000 pulses / kwh or kvarh (30 to 100ms long)			
Display capacity	99999 KWh or 999.99 MWh		999999.99KWh			
Voltage range (L-N)	184 to 276 V AC		92 to 276 V AC			
Operating frequency	50/60 Hz					
Meter constant LED	1000 flashes per KWh					
Wiring capacity (Top)	6 mm ²		4 mm ²			
Wiring capacity (Bottom)	32 mm ² (16 mm ² iEM2100/iEM2105)					
Consumption	2.5 VA		3 VA			
IP protection	IP40 front panel and IP20 casing					
Temperature	-25°C to 55°C					
Active energy	■	■	■	■	■	■
Reactive energy			■	■	■	■
Active power			■	■	■	■
Reactive power			■	■	■	■
Power Factor			■	■	■	■
Current and voltage			■	■	■	■
Frequency			■	■	■	■

iEM2100/iEM2105 dimensions

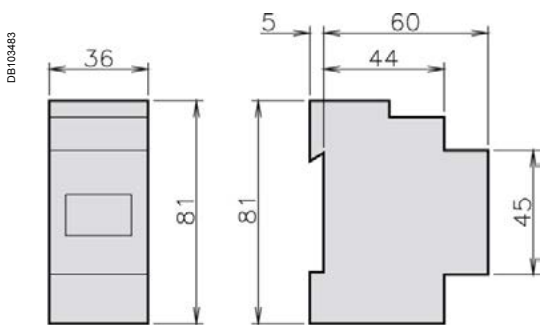

iEM2110/iEM2135/iEM2150/iEM2155 dimensions

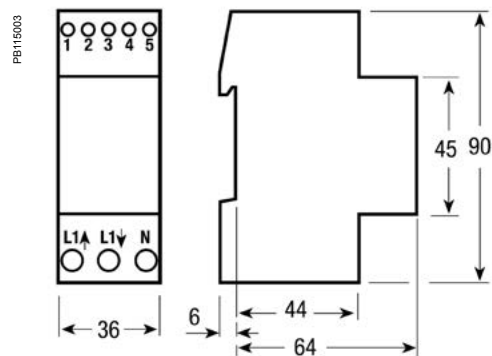

See the appropriate product Installation Guide for complete instructions.

iEM2000 and iEM2100 series commercial reference numbers

Comm. reference number	Product
A9MEM2000T	iEM2000T basic energy meter, no display
A9MEM2000	iEM2000 basic energy meter
A9MEM2010	iEM2010 energy meter, kWh pulse output
A9MEM2100	iEM2100 basic energy meter
A9MEM2050	iEM2050 modular single phase power meter 230 V - 45 A with Modbus
A9MEM2055	iEM2055 modular single phase power meter 230 V - 45 A with Modbus, MID
A9MEM2105	iEM2105 energy meter, kWh pulse output with partial meter
A9MEM2110	iEM2110 energy meter, kWh and kvarh pulse outputs with two tariffs, four quadrant energy measurement, MID certified
A9MEM2135	iEM2135 energy meter, M-Bus communication, four quadrant energy measurement, two tariffs, MID certified
A9MEM2150	iEM2150 energy meter, Modbus communication, four quadrant energy measurement
A9MEM2155	iEM2155 energy meter, Modbus communication, four quadrant energy measurement, two tariffs, MID certified

See your Schneider Electric representative for complete ordering information.

Acti9 iEM3000 Series

The Acti9 iEM3000 series energy meters is a cost-attractive, feature-rich energy metering offer for DIN rail, modular enclosures. With Modbus, BACnet, M-bus and LON protocol support, you can easily integrate these meters into commercial and non-critical buildings to add simple energy management applications to any BMS, AMR or EMS system.

Applications

Cost management applications

- Bill checking to verify that you are only charged for the energy you use
- Sub-billing individual tenants for their energy consumption, including WAGES
- Aggregation of energy consumption, including WAGES, and allocating costs per area, per usage, per shift, or per time within the same facility

Network management applications

- Basic metering of electrical parameters to better understand the behaviour of your electrical distribution system



> [Acti9 iEM3000 Series](#)

More than just kWh meters, the Acti9 iEM3000 series meters provide a full view of both energy consumption and on-site generation with full four-quadrant measurement of active and reactive energy delivered and received. Additionally, extensive real-time measurements (V, I, P, PF) give customers greater detail on their energy usage, and multiple tariffs give customers the flexibility to match the billing structure of their utility.

The solution for

All markets that can benefit from a solution that includes PowerLogic iEM3000 series meters:

- Buildings & industry
- Data centres and networks
- Infrastructure (airports, road tunnels, telecom)

Benefits

Optimise your energy consumption & enable energy efficiency practices

- Collect and analyse energy consumption data from each area for each type of load or circuit
- Gain an accurate understanding of business expenses by allocating the energy-related costs
- Use information to implement actions designed to reduce energy consumption

Monitor the energy consumption of your tenants or customers and establish accurate invoices

- Drive energy-efficient behaviour
- Allow building owners to bill tenants for individual measured utility usage
- Give accurate and achievable objectives for energy savings

Competitive advantages

- Compact size
- MID compliant (selected models) providing certified accuracy and data security
- Programmable digital inputs/outputs
- Multi-tariff capability
- Onboard Modbus, LON, M-bus or BACnet communication
- A complete range of energy meters
- Compatible with Acti9 range

Energy management system:

To get the most effective use from your Schneider Electric measurement and metering devices, we offer a range of dedicated data loggers and gateways for your building energy management.

Conformity of standards

- IEC 61557-12
- IEC 62053-21/22
- IEC 62053-23
- EN 50470-3
- EN 50470-1
- IEC 61036
- IEC 61010

Acti9 iEM3000 Series

iEM3000 feature selection

		iEM3200 iEM3300	iEM3210 iEM3310	iEM3215	iEM3250 iEM3350	iEM3235 iEM3335	iEM3255 iEM3355	iEM3265 iEM3365	iEM3275 iEM3375
Self-powered		■	■	■	■	■	■	■	■
Width (18mm module)		5/7	5/7	5	5/7	5/7	5/7	5/7	5/7
Direct measurement (up to)		-/125 A	-/125 A	-	-/125 A	-/125 A	-/125 A	-/125 A	-/125 A
Measurement input through CTs (1A, 5A)		■ / -	■ / -	■	■ / -	■ / -	■ / -	■ / -	■ / -
Measurement input through VTs					■ / -	■ / -	■ / -	■ / -	■ / -
Active Energy measurements class		0.5S/1	0.5S/1	0.5S	0.5S/1	0.5S/1	0.5S/1	0.5S/1	0.5S/1
Four Quadrant Energy measurement						■	■	■	■
Electrical parameter measurements (I, V, P,...)					■	■	■	■	■
Multi-tariff (internal clock)				4		4	4	4	4
Multi-tariff (external control)				4		2	2	2	2
Measurement display (no. of line)		3	3	3	3	3	3	3	3
Digital inputs	Programmable (Tariff control or WAGES input)					1	1	1	1
	Tariff control only			2					
Digital outputs	Programmable (Kwh pulse or KW overload alarm)					1	1	1	
	Kwh pulse only		1						
Communication protocols	M-bus					■			
	Modbus				■		■		
	BACnet							■	
	Lon								■
MID (legal metrology certification)			■	■		■	■	■	■
Commercial reference numbers	A9MEM3200	A9MEM3210	A9MEM3215	A9MEM3250	A9MEM3235	A9MEM3255	A9MEM3265	A9MEM3275	
	A9MEM3300	A9MEM3310		A9MEM3350	A9MEM3335	A9MEM3355			

See your Schneider Electric representative for complete ordering information.

How to read table: If a cell contains a single value, that value applies to all meter models identified in the header cell(s). For cells with multiple values, the values correspond from left to right with the meter models listed from top to bottom for each associated header cell. For example, a cell with "A / B" means A for iEM32xx models, and B for iEM33xx models

Acti9 IEM3200 series technical specifications

Technical specifications								
	iEM3200	iEM3210	iEM3215	iEM3250	iEM3235	iEM3255	iEM3265	iEM3275
Max current (1A/5A CT connected)	6 A							
Meter constant LED	5000/kWh							
Pulse output frequency		Up to 500p/kWh			Up to 500p/kWh		Up to 500p/kWh	
Multi-tariff			4 tariff		4 tariffs		4 tariffs	
Communication				Modbus	Modbus	Modbus	BACnet	LON
DI/DO		0/1	2/0		1/1	1/1	1/1	1/0
MID (EN50470-3) ⁽¹⁾		■	■		■	■	■	■
Network	1P+N, 3P, 3P+N support CTs			1P+N, 3P, 3P+N support CTs & VTs				
Accuracy class	Class 0.5S (IEC 62053-22 and IEC61557-12) Class C (EN50470-3) ⁽¹⁾							
Wiring capacity	6 mm ² for currents and 4 mm ² for voltages							
Display max.	LCD 99999999.9kWh or 99999999.9MWh							
Voltage (L-L)	3 x 100/173 V AC to 3 x 277/480 V AC (50/60 Hz)							
IP protection	IP40 front panel and IP20 casing							
Temperature	-25°C to 55°C (K55)							
Product size	5 steps of 18 mm							
Overvoltage & measurement	Category III, Degree of pollution 2							
kWh	■	■	■	■	■	■	■	■
kVARh					■	■	■	■
Active power				■	■	■	■	■
Reactive power					■	■	■	■
Currents and voltages				■	■	■	■	■
Overload alarm					■	■	■	■
Hour counter					■	■	■	■

⁽¹⁾ Only for iEM32xx used with 5 A CTs.

Acti9 iEM3300 series technical specifications

Technical specifications							
	iEM3300	iEM3310	iEM3350	iEM3335	iEM3355	iEM3365	iEM3375
Max current (direct connection)	125 A for iEM3300 models						
Meter constant LED	500/kWh						
Pulse output		Up to 1000 p/kWh		Up to 1000 p/kWh		Up to 1000 p/kWh	
Multi-tariff				4 tariffs		4 tariffs	
Communication			Modbus	Modbus	Modbus	BACnet	LON
DI/DO		0/1		1/1	1/1	1/1	1/0
MID (EN50470-3)		■		■	■	■	■
Network	1P+N, 3P, 3P+N						
Accuracy class	Class 1 (IEC 62053-21 and IEC 61557-12) Class B (EN 50470-3)						
Wiring capacity	50 mm ² for iEM3300 models						
Display max.	LCD 99999999.9kWh						
Voltage (L-L)	3 x 100/173 V AC to 3 x 277/480 V AC (50/60 Hz)						
IP protection	IP40 front panel and IP20 casing						
Temperature	-25°C to 55°C (K55)						
Product size	7 x 18 mm for iEM3300 models						
Overvoltage and measurement	Category III, Degree of pollution 2						
kWh	■	■	■	■	■	■	■
kVARh				■	■	■	■
Active power			■	■	■	■	■
Reactive power				■	■	■	■
Currents and voltages			■	■	■	■	■
Overload alarm				■	■	■	■
Hour counter				■	■	■	■

iEM3000/iEM3200 series dimensions

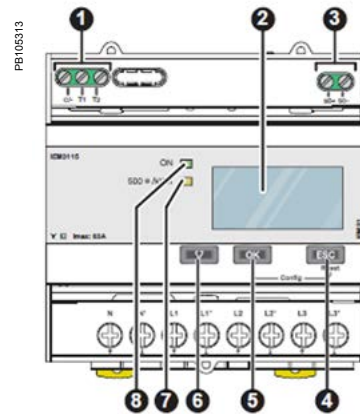
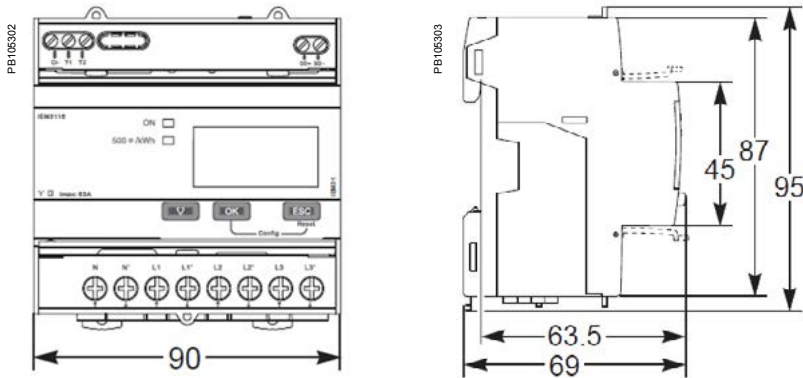

Acti9 iEM3200 Series front flaps open and closed

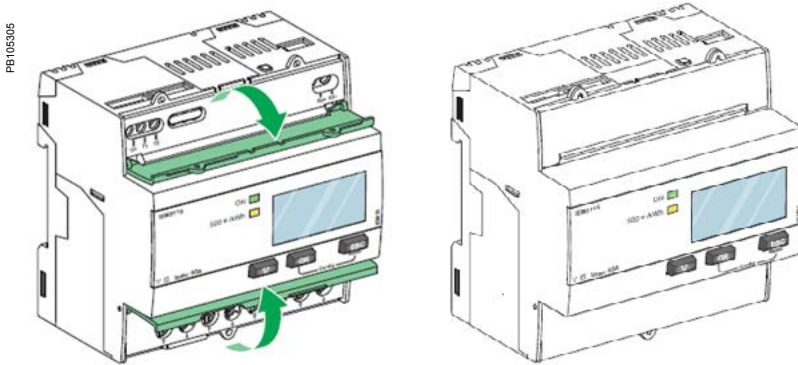

Acti9 iEM3000 Series parts

1. Digital inputs for tariff control (iEM3215)
2. Display for measurement and configuration
3. Pulse out for remote transfer (iEM3210)
4. ESC Cancellation
5. OK Confirmation
6. Selection
7. Flashing yellow meter indicator to check accuracy
8. Green indicator: on/off, error

iEM3300 series dimensions

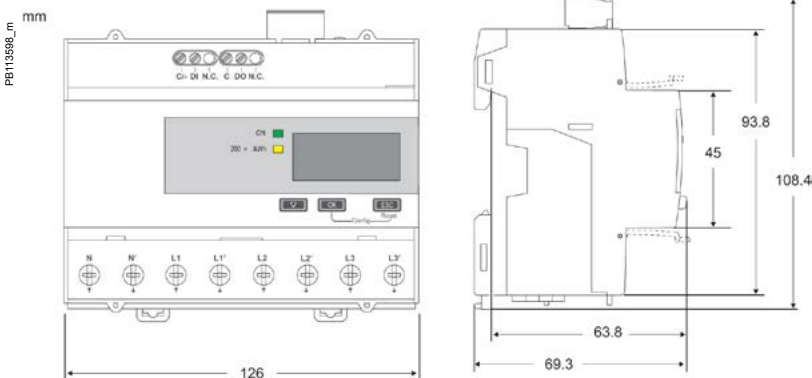
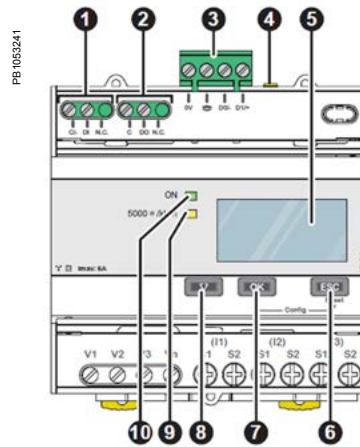
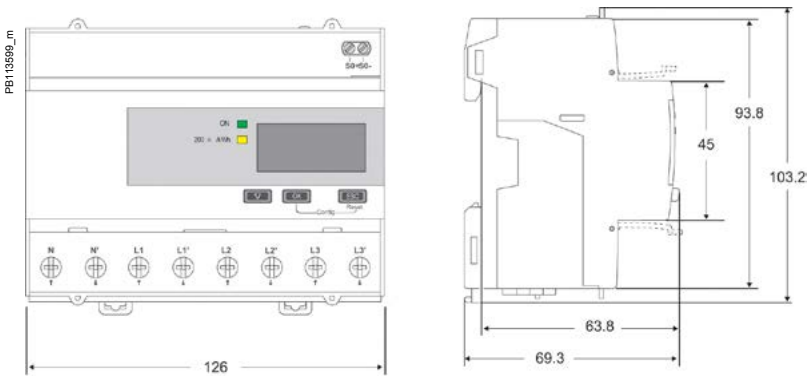

Acti9 iEM3000 Series parts

1. Digital inputs for tariff control (iEM3215)
2. Display for measurement and configuration
3. Pulse out for remote transfer (iEM3210)
4. ESC Cancellation
5. OK Confirmation
6. Selection
7. Flashing yellow meter indicator to check accuracy
8. Green indicator: on/off, error

Please see the appropriate **Installation Guide** for accurate and complete information on the installation of this product.



Basic multi-function metering



Overview

A range of meters designed for cost management and simple network management. Affordable to buy and easy to choose, the highly-capable PowerLogic PM5000 series meters are designed to provide the best combination of features to match all your energy cost management needs.

As well as pin-point energy savings, optimal equipment efficiency and utilisation, basic multi-function meters perform a high level assessment of the power quality in an electrical network.

- PowerLogic PM3000
- PowerLogic PM5000



> [PowerLogic PM3000](#)



> [PowerLogic PM5000](#)

PM3000 series

The PowerLogic PM3000 series power meters are a cost-attractive, feature-rich range of DIN rail-mounted power meters that offers all the measurement capabilities required to monitor an electrical installation.

Ideal for power metering and network monitoring applications that seek to improve the availability and reliability of your electrical distribution system, the meters are also fully capable of supporting sub-metering and cost allocation applications.

Applications

Cost management applications

- Bill checking to verify that you are only charged for the energy you use
- Aggregation of energy consumption, including WAGES, and cost allocation per area, per usage, per shift or per time within the same facility
- Energy cost and usage analysis per zone, per usage or per time period to optimise energy usage

Network management applications

- Metering of electrical parameters to better understand the behaviour of your electrical distribution system



> [PowerLogic PM3000](#)

The solution for

All markets that can benefit from a solution that includes PowerLogic PM3000 series meters:

- Buildings
- Industry
- Data centres and networks
- Infrastructure (e.g. airports, road tunnels, telecom)

Benefits

Optimise your energy consumption & enable energy efficiency practices

- Collect and analyse energy consumption data from each area for each type of load or circuit
- Gain an accurate understanding of business expenses by allocating the energy-related costs
- Identify savings opportunities
- Use information to implement actions designed to reduce energy consumption

Competitive advantages

Connectivity advantages

- Programmable digital input
 - External tariff control signal (4 tariff)
 - Remote reset partial counter
 - External status like breaker status
 - Collect WAGES pulses
 - Programmable digital output
 - Alarm (PM3255)
 - KWh pulses
 - Graphic LCD display
 - Modbus RS-485 with screw terminals
- Multi-tariff capability
The PM3000 series allows users to arrange KWh consumption in four different registers. This can be controlled by:
- Digital inputs. Signal can be provided by PLC or utilities
 - Internal clock programmable by HMI
 - Through communication

This function allows users to:

- Make tenant metering for dual source applications to differentiate backup source or utility source
- Understand well the consumption during peak time and off-peak time, weekdays and weekends, holiday and working days etc.
- Follow up feeders consumption in line with utility tariff rates

Power management solutions

Schneider Electric provides innovative power management solutions to increase your energy efficiency and cost savings, maximise electrical network reliability and availability, and optimise electrical asset performance.

Conformity of standards

- | | |
|----------------|----------------|
| • IEC 61557-12 | • IEC 62053-23 |
| • IEC 61326-1 | • EN 50470-1 |
| • IEC 62052-11 | • EN 50470-3 |
| • IEC 62053-21 | • IEC 61010-1 |
| • IEC 62053-22 | • EN 55022 |

PM3000 series

PM3000 series feature selection				
	PM3200	PM3210	PM3250	PM3255
Performance standard				
IEC61557-12 PMD/Sx/K55/0.5	■	■	■	■
General				
Use on LV and HV systems	■	■	■	■
Number of samples per cycle	32	32	32	32
CT input 1A/5A	■	■	■	■
VT input	■	■	■	■
Multi-tariff	4	4	4	4
Multi-lingual backlit display	■	■	■	■
Instantaneous rms values				
Current, voltage Per phase and average	■	■	■	■
Active, reactive, apparent power Total and per phase	■	■	■	■
Power factor Total and per phase	■	■	■	■
Energy values				
Active, reactive and apparent energy; import and export	■	■	■	■
Demand value				
Current, power (active, reactive, apparent) demand; present	■	■	■	■
Current, power (active, reactive, apparent) demand; peak		■	■	■
Power quality measurements				
THD Current and voltage		■	■	■
Data recording				
Min/max of the instantaneous values	■	■	■	■
Power demand logs				■
Energy consumption log (day, week, month)				■
Alarms with timestamping		5	5	15
Digital inputs/digital outputs		0/1		2/2
Communication				
RS-485 port			■	■
Modbus protocol			■	■
Commercial reference number	METSEPM3200	METSEPM3210	METSEPM3250	METSEPM3255

See your Schneider Electric representative for complete ordering information.

PM3000 series

PM3000 technical specifications

Type of measurement	True rms up to the 15th harmonic on three-phase (3P,3P+N) and single-phase AC systems. 32 samples per cycle
Measurement accuracy	
Current with x/5A CTs	0.3 % from 0.5 A to 6 A
Current with x/1A CTs	0.5 % from 0.1 A to 1.2 A
Voltage	0.3 % from 50 V to 330 V (Ph-N), from 80 V to 570 V (Ph-Ph)
Power factor	±0.005 from 0.5 A to 6 A with x/5 A CTs; from 0.1A to 1.2 A with x/1 A CTs and from 0.5 L to 0.8 C
Active/Apparent Power with x/5A CTs	Class 0.5
Active/Apparent Power with x/1A CTs	Class 1
Reactive power	Class 2
Frequency	0.05 % from 45 to 65 Hz
Active energy with x/5A CTs	IEC 62053-22 Class 0.5s
Active energy with x/1A CTs	IEC 62053-21 Class 1
Reactive energy	IEC 62053-23 Class 2
Data update rate	
Update rate	1s
Input-voltage characteristics	
Measured voltage	50 V to 330 V AC (direct / VT secondary Ph-N) 80 V to 570 V AC (direct / VT secondary Ph-Ph) up to 1 MV AC (with external VT)
Frequency range	45 Hz to 65 Hz
Input-current characteristics	
CT primary	Adjustable from 1 A to 32767 A
CT secondary	1 A or 5 A
Measurement input range with x/5A CTs	0.05 A to 6 A
Measurement input range with x/1A CTs	0.02 A to 1.2 A
Permissible overload	10 A continuous, 20 A for 10s/hour
Control Power	
AC	100/173 to 277/480 V AC (+/-20%), 3 W/5 VA; 45 Hz to 65 Hz
DC	100 to 300 V DC, 3 W
Input	
Digital inputs (PM3255)	11 to 40 V DC, 24 V DC nominal, ≤4mA maximum burden, 3.5kVrms insulation
Output	
Digital output (PM3210)	Optocoupler, polarity sensitive, 5 to 30 V, 15 mA max, 3.5kVrms insulation
Digital outputs (PM3255)	Solid state relay, polarity insensitive, 5 to 40 V, 50 mA max, 50 Ω max, 3.5kVrms insulation

PM3000 series

PM3000 technical specifications	
Mechanical characteristics	
Weight	0.26 kg
IP degree of protection (IEC 60529)	IP40 front panel, IP20 meter body
Dimension	90 x 95 x 70 mm
Environmental conditions	
Operating temperature	-25 °C to 55 °C
Storage temperature	-40 °C to 85 °C
Humidity rating	5 to 95% RH at 50 °C (non-condensing)
Pollution degree	2
Metering category	III, for distribution systems up to 277/480 V AC
Dielectric withstand	As per IEC61010-1, Doubled insulated front panel display
Altitude	3000 m max
Electromagnetic compatibility	
Electrostatic discharge	Level IV (IEC 61000-4-2)
Immunity to radiated fields	Level III (IEC 61000-4-3)
Immunity to fast transients	Level IV (IEC 61000-4-4)
Immunity to surge	Level IV (IEC 61000-4-5)
Conducted immunity	Level III (IEC 61000-4-6)
Immunity to power frequency magnetic fields	0.5mT (IEC 61000-4-8)
Conducted and radiated emissions	Class B (EN 55022)
Safety	
	CE as per IEC 61010-1g
Communication	
RS-485 port	Half duplex, from 9600 up to 38400 baud, Modbus RTU (double insulation)
Display characteristics	
Dimensions (VA)	43 mm x 34.6 mm
Display resolution	128 x 96 dots
Standard compliance	
	IEC 61557-12, EN 61557-12 IEC 61010-1, UL 61010-1 IEC 62052-11, IEC 62053-21, IEC 62053-22, IEC 62053-23 EN 50470-1, EN 50470-3

g Protected throughout by double insulation

PM3200 series front of meter

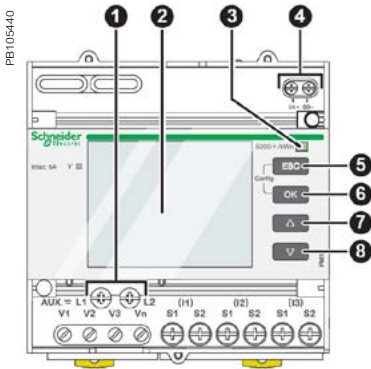

- Front of meter parts**
- 1 Control power
 - 2 Display with white backlight
 - 3 Flashing yellow meter indicator (to check accuracy)
 - 4 Pulse output for remote transfer (PM3210)
 - 5 **ESC** Cancellation
 - 6 **OK** Confirmation
 - 7 **▲** Up
 - 8 **▼** Down

PM3200 series dimensions

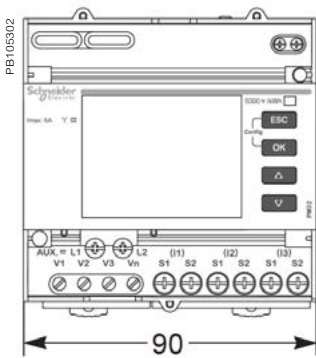

mm

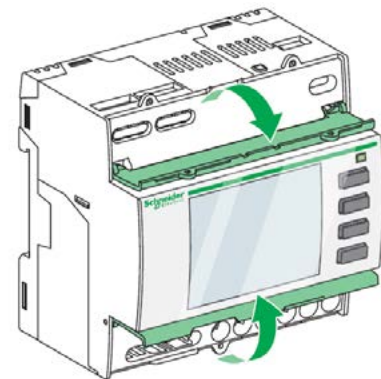
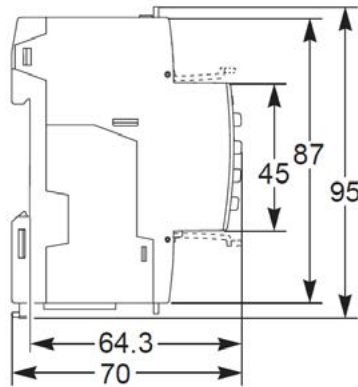

PM3200 top and lower flaps

PM3200 series easy installation

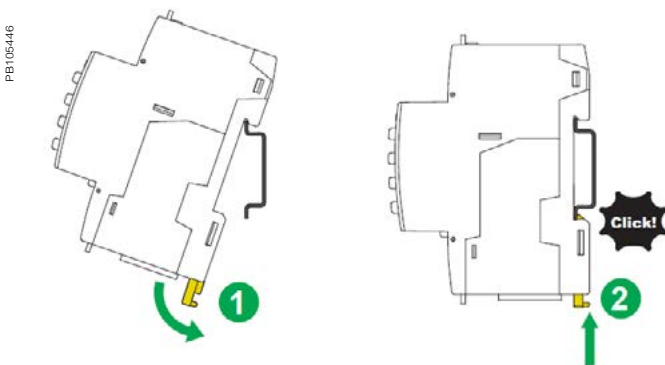

Please see the appropriate **Installation Guide** for accurate and complete information on the installation of this product.

PM5000 series

The PowerLogic PM5000 series power meters are the new benchmark in affordable, precision metering.

The value you want, the precision you need. Compact, affordable power meters with high-end cost capabilities and basic mobile energy management.

Applications

Capable of essential cost management:

- Sub-billing/tenant metering
- Equipment sub-billing
- Energy cost allocation

Also ideal for electrical network management:

- Track real-time power conditions
- Monitor control functions
- Provide basic power quality values
- Monitor equipment and network status
- BACnet/IP, Ethernet/IP, and DNP3.0 protocol support



PB118061

The solution for

Markets that can benefit from a solution that includes PowerLogic PM5000 series meters:

- Buildings
- Industry
- Healthcare
- Data Center and networks
- Infrastructure

Benefits

System integrators' benefit

- Ease of integration
- Ease of setup
- Cost effectiveness

Panel builders' benefit

- Ease of installation
- Cost effectiveness
- Aesthetically pleasing
- Simplified ordering

End users' benefit

- Ease of use
- Precision metering & sub-billing
- Billing flexibility
- Comprehensive, consistent and superior performance

Competitive advantages

- Easy to install and operate
- Easy for circuit breaker monitoring and control
- Power quality analysis
- Load management combined with alarm and timestamping
- High performance and accuracy
- MID ready compliance for legal billing application
- BACnet/IP, Ethernet/IP, and DNP3.0 protocol support

Power management solutions

Schneider Electric provides innovative power management solutions to increase your energy efficiency and cost savings, maximize electrical network reliability and availability, and optimize electrical asset performance.

Conformity of standards

- | | |
|----------------|---------------|
| • IEC 61557-12 | • IEC 61010-1 |
| • IEC 62053-22 | • IEC 61326-1 |
| • IEC 62053-24 | • CISPR22 |
| • IEEE 802.3 | Class B |
| • EN 50470-1 | • ODVA |
| • EN 50470-3 | certification |

PM5000 series

PM5000 series feature selection												
	PM5100		PM5300						PM5500			PM5600
	PM5100	PM5110	PM5310	PM5310R	PM5320	PM5320R	PM5330	PM5340	PM5560	PM5563	PM5563RD	PM5650
Installation												
Fast installation, panel mount with integrated display	b	b	b	b	b	b	b	b	b	–	–	b
Fast installation, DIN rail mountable	–	–	–	–	–	–	–	–	–	b	b	–
Accuracy	CL 0.5S	CL 0.5S	CL 0.5S	CL 0.5S	CL 0.5S	CL 0.5S	CL 0.5S	CL 0.5S	CL 0.2S	CL 0.2S	CL 0.2S	CL 0.2S
Display												
Backlit LCD, multilingual, bar graphs, 6 lines, 4 concurrent values	b	b	b	b	b	b	b	b	b	b	b	b
Power and energy metering												
3-ph voltage, current, power, demand, energy, frequency, power factor	b	b	b	b	b	b	b	b	b	b	b	b
Multi-tariff	–	–	4	4	4	4	4	4	8	8	8	8
Power quality analysis												
THD, thd, TDD	b	b	b	b	b	b	b	b	b	b	b	b
Harmonics, individual (odd) up to	15th	15th	31st	31st	31st	31st	31st	31st	63rd	63rd	63rd	63rd
Waveform capture & sag/swell detection	–	–	–	–	–	–	–	–	–	–	–	8 cycles @ 128 cycles/sec
I/Os and relays												
I/Os	1DO	1DO	2DI/2DO	2DI/2DO	2DI/2DO	2DI/2DO	2DI/2DO	2DI/2DO	4DI/2DO	4DI/2DO	4DI/2DO	4DI/2DO
Relays	0	0	0	0	0	0	2	2	0	0	0	0
Alarms and control												
Alarms	33	33	35	35	35	35	35	35	52	52	52	52
Set point response time, seconds	1	1	1	1	1	1	1	1	1	1	1	1
Single and multi-condition alarms	–	–	b	b	b	b	b	b	b	b	b	b
Boolean alarm logic	–	–	–	–	–	–	–	–	b	b	b	b
Memory for data logging	–	–	256KB	256KB	256KB	256KB	256KB	256KB	1.1 MB	1.1 MB	1.1 MB	1.1 MB
Communications												
Serial ports with modbus protocol	–	1	1	1	–	–	1	–	1	1	1	1
Ethernet port with Modbus TCP protocol	–	–	–	–	1	1	–	1	2g	2g	2g	2g
BACnet/IP protocol	–	–	–	–	b	b	–	b	b	b	b	b
Ethernet/IP protocol	–	–	–	–	–	–	–	–	b	b	b	b
DNP3.0 over Ethernet	–	–	–	–	–	–	–	–	b	b	b	b
Onboard web server with web pages	–	–	–	–	–	–	–	–	b	b	b	b
Serial to Ethernet gateway	–	–	–	–	–	–	–	–	b	b	b	b
MID ready compliance, EN50470-1/3, Annex B & Annex D Class C	–	PM5111	–	–	–	–	PM5331	PM5341	PM5561	–	–	–
Short ref. numbers	PM5100	PM5110	PM5310	PM5310R	PM5320	PM5320R	PM5330	PM5340	PM5560	PM5563	PM5563RD	PM5650
(See table below for complete commercial reference numbers)												

g 2 Ethernet ports for daisy chain, one IP address. NOTE: PM5310R and PM5320R must be used with Schneider Electric's "Quick Click" 3-in-1 LVCTs

PM5000 series

PM5000 technical specifications		PM5100	PM5300	PM5500	PM5600
Use on LV and MV systems				b	
Basic metering with THD and min/max readings				b	
Instantaneous rms values					
Current	per phase, neutral and ground (PM5500)			b	
Voltage	Total, per phase L-L and L-N			b	
Frequency				b	
Real, reactive, and apparent power	Total and per phase			Signed, Four Quadrant	
True Power Factor	Total and per phase			Signed, Four Quadrant	
Displacement PF	Total and per phase			Signed, Four Quadrant	
% Unbalanced I, V L-N, V L-L				b	
Direct monitoring of neutral current					b
Energy values					
Accumulated Active, Reactive and Apparent Energy		Received/Delivered; Net and absolute; Time Counters			
Demand value					
Current average		Present, Last, Predicted, Peak, and Peak Date Time			
Active power		Present, Last, Predicted, Peak, and Peak Date Time			
Reactive power		Present, Last, Predicted, Peak, and Peak Date Time			
Apparent power		Present, Last, Predicted, Peak, and Peak Date Time			
Peak demand with timestamping D/T for current and powers				b	
Demand calculation	Sliding, fixed and rolling block, thermal methods			b	
Synchronisation of the measurement window to input, communication command or internal clock				b	
Settable Demand intervals				b	
Demand calculation for Pulse input (WAGES)					b
Other measurements					
I/O timer				b	
Operating timer				b	
Load timer				b	
Alarm counters and alarm logs				b	
Power quality measurements					
THD, thd (Total Harmonic Distortion) I, VLN, VLL				I, VLN, VLL	
TDD (Total Demand Distortion)				b	
Individual harmonics (odds)		15th	31st		63rd
Neutral Current metering with ground current calculation					b
Waveform capture and sag/swell detection					8 cycles @ 128 cycles/sec
Data recording					
Min/max of instantaneous values, plus phase identification ^g				b	
Alarms with 1s timestamping ^g				b	
Data logging			2 fixed parameters kWh and kVAh with configurable interval and duration (e.g. 2 parameters for 60 days at 15 minutes interval)	Up to 14 selectable parameters with configurable interval and duration (e.g. 6 parameters for 90 days at 15 minutes interval)	
Memory capacity			256 kB	1.1 MB	
Min/max log		b	b	b	
Maintenance, alarm and event logs			b	b	
Customisable data logs				b	

^gStored in non-volatile memory

PM5000 series

PM5000 technical specifications

		PM5100	PM5300	PM5500	PM5600
Inputs / Outputs / Mechanical Relays					
Digital inputs			2 (SI1, SI2)	4 (SI1, SI2, SI3, SI4) with WAGES support	
Digital outputs		1 (kWh only)	2 (configurable)	2 (configurable)	
Form A Relay outputs			2		
Timestamp resolution in seconds		1	1	1	1
Whetting voltage			b		
Type of measurement: True rms on three-phase (3P, 3P + N)		64 samples per cycle		128 samples per cycle	
Measurement accuracy	IEC 61557-12	PMD/[SD]/[SS]/K70/0.5		PMD/[SD]/[SS]/K70/0.2	
	Active Energy	Class 0.5S as per IEC 62053-22		Class 0.2S as per IEC 62053-22	
	Reactive Energy	Class 2S as per IEC 62053-24		Class 2S as per IEC 62053-24	
	Active Energy	±0.5 %		±0.2 %	
	Reactive Energy	±2 %		±1 %	
	Active Power	Class 0.5 as per IEC 61557-12		Class 0.2 as per IEC 61557-12	
	Apparent Power	Class 0.5 as per IEC 61557-12			
	Current, Phase	Class 0.5 as per IEC 61557-12		±0.15 %	
	Voltage, L-N	Class 0.5 as per IEC 61557-12		±0.1 %	
	Frequency	±0.05 %			
MID Directive EN50470-1, EN50470-3	Annex B and Annex D (Optional model references) Class C				
Input-voltage (up to 1.0 MV AC max, with voltage transformer)	Nominal Measured Voltage range	20 V L-N / 35 V L-L to 400 V L-N /690 V L-L absolute range 35 V L-L to 760 V L-L		20 V L-N / 20 V L-L to 400 V L-N /690 V L-L absolute range 20 V L-L to 828 V L-L	
	Impedance	5 MΩ			
	F nom	50 or 60 Hz ±5 %		50 or 60 Hz ±10 %	
Input-current (configurable for 1 or 5 A secondary CTs)	I nom	5 A			
	Measured Amps with over range and Crest Factor	Starting current: 5 mA Operating range: 50 mA to 8.5 A		Starting current: 5 mA Operating range: 50 mA to 10 A	
	Withstand	Continuous 20 A, 10 s/hr 50 A, 1s/hr 500 A			
	Impedance	< 0.3 mΩ			
	F nom	50 or 60 Hz ±5 %		50 or 60 Hz ±10 %	
	Burden	<0.026 VA at 8.5 A			
AC control power	Operating range	100 - 277 V AC L-N / 415 V L-L +/-10 % CAT III 300V class per IEC 61010		100-480 V AC ±10 % CAT III 600V class per IEC 61010	
	Burden	<5 W,11 VA at 415V L-L		<5W/16.0 VA at 480 V AC	
	Frequency	45 to 65 Hz			
	Ride-through time	80 mS typical at 120V AC and maximum burden. 100 mS typical at 230 V AC and maximum burden 100 mS typical at 415 V AC and maximum burden		35 ms typical at 120 V L-N and maximum burden 129 ms typical at 230 V L-N and maximum burden	
DC control power	Operating range	125-250 V DC ±20 %			
	Burden	<4 W at 250 V DC		typical 3.1W at 125 V DC, max. 5W	
	Ride-through time	50 mS typical at 125 V DC and maximum burden			

PM5000 series

PM5000 technical specifications

		PM5100	PM5300	PM5500	PM5600	
Relay	Max output frequency		0.5 Hz maximum (1 second ON / 1 second OFF - min times)			
	Switching current		250 V AC at 8.0 Amps, 25 k cycles, resistive 30 V DC at 2.0 Amps, 75 k cycles, resistive 30 V DC at 5.0 Amps, 12.5 k cycles, resistive			
	Isolation		2.5 kV rms			
Outputs	Digital outputs	1	2	2	2	
	Max load voltage	40 V DC		30 V AC / 60 V DC		
	Max load current	20 mA		125 mA		
	On Resistance	50 Ω max		8 Ω		
	Meter constant	from 1 to 9,999,999 pulses per kWh				
	Pulse width for Digital Output	50 % duty cycle				
	Pulse frequency for Digital Output	25 Hz max.				
	Leakage current	0.03 micro Amps		1 micro Amps		
	Isolation	5 kV rms		2.5 kV rms		
	Optical outputs	Pulse width (LED)	200 ms			
Pulse frequency		50 Hz. max.		2.5 kHz. max		
Meter constant		from 1 to 9,999,999 pulses per k_h				
Status Inputs	ON Voltage		18.5 to 36 V DC	30 V AC / 60 V DC max		
	OFF Voltage			0 to 4 V DC		
	Input Resistance		110 k Ω	100 k Ω		
	Maximum Frequency		2 Hz (T ON min = T OFF min = 250 ms)	25 Hz (T ON min = T OFF min = 20 ms)		
	Response Time		20 ms	10 ms		
	Opto Isolation		5 kV rms	2.5 kV rms		
	Wetting output		24 V DC/ 8 mA max			
	Input Burden		2mA @24V DC		2 mA @ 24 V AC/DC	
Mechanical characteristics						
Product weight		380 g	430 g	450 g	450 g	
IP degree of protection (IEC 60529)		IP52 front display, (IP54 for PM53xx and PM55xx), IP30 meter body				
Dimensions W x H x D [protrusion from cabinet]		96 x 96 x 72 mm (77 mm for PM5500) (depth of meter from housing mounting flange) [13 mm]				
Mounting position		Vertical				
Panel thickness		6 mm maximum				
Environmental characteristics						
Operating temperature	Meter	-25 °C to 70 °C				
	Display (Display functions to -25° with reduced performance)	-25 °C to 70 °C				
Storage temp.		-40 °C to 85 °C				
Humidity range		5 to 95 % RH at 50 °C (non-condensing)				
Pollution degree		2				
Altitude		2000 m CAT III / 3000 m CAT II		3000 m max. CAT III		

PM5000 technical specifications

Electromagnetic compatibility	
Harmonic current emissions	IEC 61000-3-2
Flicker emissions	IEC 61000-3-3
Electrostatic discharge	IEC 61000-4-2
Immunity to radiated fields	IEC 61000-4-3
Immunity to fast transients	IEC 61000-4-4
Immunity to surge	IEC 61000-4-5
Conducted immunity 150 kHz to 80 MHz	IEC 61000-4-6
Immunity to magnetic fields	IEC 61000-4-8
Immunity to voltage dips	IEC 61000-4-11
Radiated emissions	FCC part 15, EN 55022 Class B
Conducted emissions	FCC part 15, EN 55022 Class B

Safety	PM5100	PM5300	PM5500	PM5600
Europe	CE, as per IEC 61010-1 Ed. 3, IEC 62052-11 & IEC 61557-12			
U.S. and Canada	cULus as per UL 61010-1 (3rd Edition)			
Measurement category (Voltage & Current inputs)	CAT III up to 400 V L-N / 690 V L-L			
Dielectric	As per IEC/UL 61010-1 Ed. 3			
Protective Class	II, Double insulated for user accessible parts			

Communication	
RS-485 port Modbus RTU, Modbus ASCII (7 or 8 bit), JBUS	2-Wire, 9600, 19200 or 38400 baud, Parity - Even, Odd, None, 1 stop bit if parity Odd or Even, 2 stop bits if None; (Optional in PM51x and PM53x)
Ethernet port: 10/100 Mbps; Modbus TCP/IP	1 Optional 2 (daisy chain only, 1 IP address)
Native Ethernet/IP & DNP3.0 over Ethernet	Yes Yes
Native BACnet/IP Support	Yes Yes Yes
Firmware and language file update	Meter firmware update via the communication ports
Isolation	2.5 kVrms, double insulated

Human machine interface	
Display type	Monochrome Graphics LCD
Resolution	128 x 128
Backlight	White LED
Viewable area (W x H)	67 x 62.5 mm
Keypad	4-button
Indicator Heartbeat / Comm activity	Green LED
Energy pulse output / Active alarm (configurable)	Optical, amber LED
Wavelength	590 to 635 nm
Maximum pulse rate	2.5 kHz

Comm ref numbers	Description
METSEPM5100	Power Meter range 72 mm depth, control power to 415 V AC, CI 0.5S, 15th harmonic, no communication, 1DO
METSEPM5110	Power Meter range 72 mm depth, control power to 415 V AC, CI 0.5S, 15th harmonic, RS-485 Modbus, 1DO
METSEPM5111	Power Meter range 72 mm depth, control power to 415 V AC, CI 0.5S, 15th harmonic, RS-485 Modbus, 1DO, MID cert.
METSEPM5310	Power Meter range 72 mm depth, control power to 415 V AC, CI 0.5S, 31st harmonic, 256 kB, RS-485 Modbus, 2DI/2DO
METSEPM5310R	Power Meter range 72 mm depth, control power to 415 V AC, CI 0.5S, 31st harmonic, 256 kB, RJ45 LVCT, RS-485 Modbus, 2DI/2DO
METSEPM5320	Power Meter range 72 mm depth, control power to 415 V AC, CI 0.5S, 31st harmonic, 256 kB, Ethernet, 2DI/2DO
METSEPM5320R	Power Meter range 72 mm depth, control power to 415 V AC, CI 0.5S, 31st harmonic, 256 kB, RJ45 LVCT, Ethernet, 2DI/2DO
METSEPM5330	Power Meter range 72 mm depth, control power to 415 V AC, CI 0.5S, 31st harmonic, 256 kB, RS-485 Modbus, 2DI/2DO, 2Relay
METSEPM5331	Power Meter range 72 mm depth, control power to 415 V AC, CI 0.5S, 31st harmonic, 256 kB, RS-485 Modbus, 2DI/2DO, 2Relay, MID cert.
METSEPM5340	Power Meter range 72 mm depth, control power to 415 V AC, CI 0.5S, 31st harmonic, 256 kB, Ethernet, 2DI/2DO, 2Relay
METSEPM5341	Power Meter range 72 mm depth, control power to 415 V AC, CI 0.5S, 31st harmonic, 256 kB, Ethernet, 2DI/2DO, 2Relay, MID cert.
METSEPM5560	Power Meter range 77 mm depth, control power to 480 V AC, CI 0.2S, 63rd harmonic, 1.1 MB, Modbus and Ethernet, 4DI/2DO
METSEPM5561	Power Meter range 77 mm depth, control power to 480 V AC, CI 0.2S, 63rd harmonic, 1.1 MB, Modbus and Ethernet, MID cert.
METSEPM5563	Power Meter range 77 mm depth, control power to 480 V AC, CI 0.2S, 63rd harmonic, 1.1 MB, DIN mount, no display, 4DI/2DO
METSEPM5563RD	Power Meter range 77 mm depth, control power to 480 V AC, CI 0.2S, 63rd harmonic, 1.1 MB, DIN mount, remote display, 4DI/2DO

PM5xxR series commercial reference numbers

Comm. reference number	Description
Other related products	
METSEPM5RD	Remote display for PM5563
METSEPM51HK	Hardware kit for PM51xx
METSEPM53HK	Hardware kit for PM53xx
METSEPM55RSK	Revenue sealing kit for PM55XX
METSEPM55HK	Hardware kit for PM55xx
METSEPM5CAB3	Remote Display cable

See your Schneider Electric representative for complete ordering information.

PM5000 Series meter flush mounting

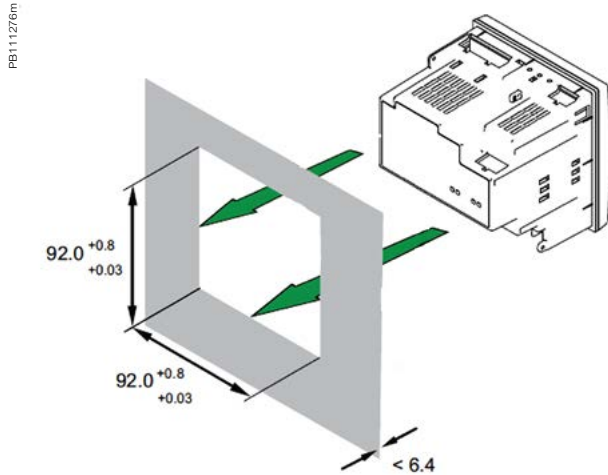

PM5000 series meter dimensions

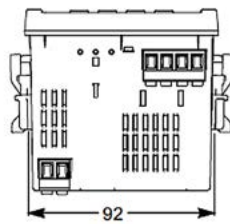
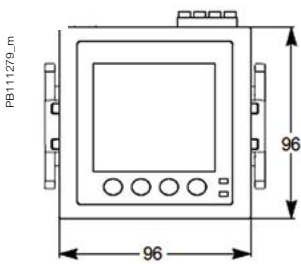

PM5000

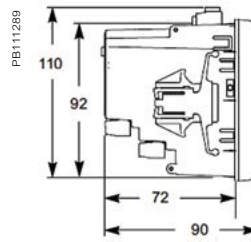

PM5100 / PM5300

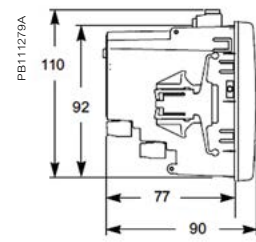

PM5500 / PM5600



- PM5000 meter parts**
- A** Menu selection buttons
 - B** LED indicators
 - C** Navigation or menu selections
 - D** Maintenance and alarm notification area

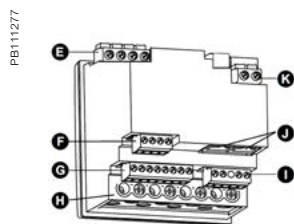

PM5500

- PM5500 / PM5600 meter parts**
- E** Voltage inputs
 - F** RS-485 comms
 - G** Digital inputs
 - H** Current inputs
 - I** Digital outputs
 - J** Ethernet ports
 - K** Control power

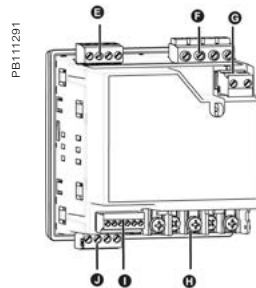

- PM5100 / PM5300 meter parts**
- E** Relay output (PM5300 only)
 - F** Voltage inputs
 - G** Control power
 - H** Current inputs
 - I** Status inputs/digital outputs
 - J** Communications port: Ethernet (PM5300 only) or RS-485

Please see the appropriate *Installation Guide* for accurate and complete information on the installation of this product.



Advanced metering applications



Overview

Advanced high performance meters are designed for mains or critical loads on MV/LV networks. They provide analysis of efficiency, losses and capacity, bill verification, power quality compliance monitoring, problem notification and diagnosis and control of loads, etc.

Power quality meters are classified as advanced meters designed to monitor service entrances and critical network locations to maximize power availability and reliability by providing a comprehensive system load profile, power quality and root cause analyses.

- PowerLogic™ PM8000
- PowerLogic™ ION9000

PB113687

P115613



> [PowerLogic™ PM8000](#)



> [PowerLogic™ ION9000](#)

PM8000 Series

The PowerLogic™ PM8000 series meters are compact, cost-effective multifunction power meters that will help you ensure reliability and efficiency of your power-critical facility.

Reveal and understand complex power quality conditions. Measure, understand and act on insightful data gathered from your entire power system. Designed for key metering points throughout your energy infrastructure, the PowerLogic PM8000 series meter has the versatility to perform nearly any job you need a meter to do, wherever you need it!

Applications

Ideal for low to high voltage applications in industrial facilities, data centres, infrastructure and other critical power environments.

PE113687



> [PowerLogic™ PM8000](#)

The solution for

Markets that can benefit from a solution that includes PowerLogic PM8000 series meters:

- Industry
- Data centres
- Infrastructure
- Healthcare
- Buildings

Benefits

- Makes understanding power quality simple to help operations personnel avoid downtime and helps ensure increased productivity and equipment life.
- Makes energy and power quality immediately relevant and actionable to support your operational and sustainability goals.

Competitive advantages

- Modular, flexible patented ION technology architecture enables a simple building block approach.
- Disturbance direction detection, modularity and compliance with latest power quality standards.
- Color screen.
- Multiple communication options.

Power management solutions

Schneider Electric provides innovative power management solutions to increase your energy efficiency and cost savings, maximize electrical network reliability and availability, and optimise electrical asset performance.

Conformity of standards

- EN 50160
- EN 50470
- IEC 61000-4-30
- IEC 61010-1
- IEC 61326-1
- IEC 61557-12
- IEC 62052-11
- IEC 62053-11
- IEC 62053-22
- IEC 62053-23
- IEC 62053-24
- UL 61010-1

PB113641



PowerLogic PM8000 series meter.

PB113668



PowerLogic PM8000 series meter - rear view.

PB113692



PowerLogic PM8000 DIN rail mounted meter.

Main characteristics

- Precision metering:
 - IEC 61557-12 PMD/SD/K70/0.2 and PMD/SS/K70/0.2 3000m (performance measuring and monitoring functions).
 - Class 0.2S accuracy IEC 62053-22, ANSI C12.20 Class 0.2 (active energy).
 - Industry leading Class 0.5S accuracy for reactive energy (IEC 62053-24).
 - Cycle-by-cycle RMS measurements updated every ½ cycle.
 - Full 'multi-utility' WAGES metering support.
 - Net metering.
 - Anti-tamper protection seals.

- PQ compliance reporting and basic PQ analysis:
 - Monitors and logs parameters in support of international PQ standards,
 - IEC 61000-4-30 Class S (test methods as per IEC 62586-2).
 - EN 50160.
 - Generates onboard PQ compliance reports accessible via onboard web pages:
 - Basic event summary and pass/fail reports, for EN 50160 for power frequency, supply voltage indication, supply voltage dips, short and long interruptions, temporary over voltages, voltage unbalance and harmonic voltage.
 - ITIC (CBEMA) and SEMI curves, with alarm categorization to support further analyses.
 - NEMA Motor Derating curve.
 - Basic meter provides EN 50160 analysis, but can be configured to provide IEEE 519.
 - Harmonic analysis:
 - THD on voltage and current, per phase, min/max, custom alarming.
 - Individual harmonic magnitudes and angles on voltage and current, up to the 63rd harmonic.
 - High resolution waveform capture: triggered manually or by alarm, captured waveforms available directly from the meter via FTP in a COMTRADE format.
 - Disturbance detection and capture: sag/swell on any current and voltage channel, alarm on disturbance event, waveform capture with per-event information.
 - Patented disturbance direction detection: provides indication of the captured disturbance occurring upstream or downstream of the meter; timestamped results provided in the event log, with degree of certainty of disturbance direction.

- Used with Schneider Electric's sophisticated software tools, provides detailed PQ reporting across entire network:
 - EN 50160 report.
 - IEC 61000-4-30 report.
 - PQ compliance summary.
 - Display of waveforms and PQ data from all connected meters.
 - Onboard web-based waveform viewer.

- Data and event logging:
 - Onboard data and event logging.
 - 512 MB of standard non-volatile memory.



PowerLogic PM8000 series meter with remote display.



PowerLogic I/O module.

- No data gaps due to network outages or server downtime.
 - Min/Max log for standard values.
 - 50 user-definable data logs, recording up to 16 parameters on a cycle-by-cycle or other user definable interval.
 - Continuous logging or 'snapshot' triggered by setpoint and stopped after defined duration.
 - Trend energy, demand and other measured parameters.
 - Forecasting via web pages: average, minimum and maximum for the next four hours and next four days.
 - Advanced time-of-use capability.
 - Security / event log: alarm conditions, metering configuration changes, power outages, firmware download, and user login/logout all timestamped to ± 1 millisecond.
- Alarming and control:
 - 50+ definable alarms to log critical event data, trigger waveform recording, or perform control function.
 - Trigger on any condition, with 1/2-cycle and 1-second response time.
 - Combine alarms using Boolean logic and to create alarm levels.
 - Alarm notification via email.
 - In conjunction with Schneider Electric's software, alarms and software alarms and alarm frequency are categorized and trended for easy evaluation of worsening/improving conditions.

Usability

- Easy installation and setup:
 - Panel and DIN rail mounting options, remote display option.
 - Pluggable connectors.
 - Free setup application simplifies meter configuration.
 - Auto-discovery using DPWS (Device Profile Web Services).
 - DHCP for automatic IP address configuration.
- Front panel:
 - Easy to read color graphic display.
 - Simple, intuitive menu navigation with multi-language (8) support.
- Flexible remote communications:
 - Multiple simultaneously operating communication ports and protocols allow interfacing with other automation systems; (e.g. waveforms, alarms, billing data, etc.) can be uploaded for viewing/analysis while other systems access real-time information.
 - Supports Modbus, ION, DNP3, IEC 61850.
 - Dual port Ethernet: 10/100BASE-TX; supports IPV4 and IPV6; daisy-chaining capability removes need for additional switches.
 - Create redundant network loop using Rapid Spanning Tree Protocol (RSTP) and managed Ethernet switches.
 - Customize TCP/IP port numbers and enable/disable individual ports.
 - RS-485 2-wire connection, up to 115,200 baud, Modbus RTU, ION and DNP3 protocols.
 - Ethernet to serial gateway with Modbus Master functionality, connecting to 31 downstream serial Modbus devices. Also supports Modbus Mastering over TCP/IP (Ethernet) network.
 - Full function web server with factory and customizable pages to access real-time and PQ compliance data.
 - Push historical data via email.
 - Advanced security: Up to 50 configurable user accounts.

PB113086



PowerLogic PM8000 series meter with I/O modules.

- Time synchronization via:
 - GPS clock (RS-485) or IRIG-B (digital input) to ± 1 millisecond.
 - Network Time Protocol (NTP/SNTP).
 - Time set function from Schneider Electric software server.

Adaptability

- ION™ frameworks allow customisable, scalable applications, object-oriented programming, compartmentalizes functions, and increases flexibility and adaptability.
- Applications include: access and aggregate data from Modbus devices on serial port or across the network (Modbus TCP/IP), logging and/or processing data by totaling, unit conversion or other calculations, applying complex logic for alarming or control operations, data visualization via web pages.

Standard meter I/O

- 3 digital status/counter inputs.
- 1 KY (form A) energy pulse output for interfacing with other systems.

Modular I/O options

- Optional expansion modules.
- Up to 4 modules per meter.

Option modules include:

- Digital module:
 - 6 digital status/counter inputs.
 - 2 Form C relay outputs, 250 V, 8 A.
- Analog module:
 - 4 analog inputs (4-20 mA; 0-30 V).
 - 2 analog outputs (4-20 mA; 0-10 V) for interfacing with building management sensors and systems.

PB113094

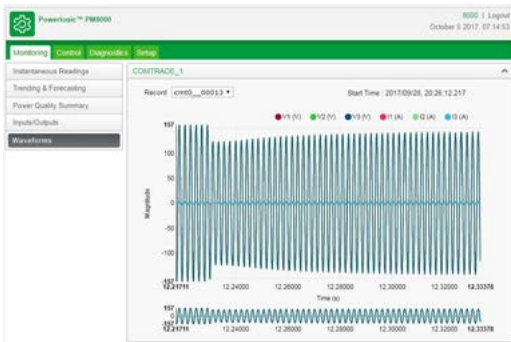

PowerLogic PM8000 series waveform web page sample

PB113093



PowerLogic PM8000 series CBEMA web page sample

PB113095

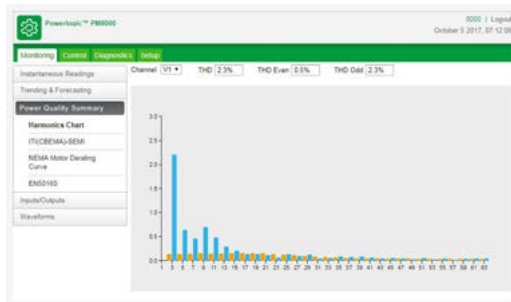

PowerLogic PM8000 series PQ harmonics web page sample

PB113696



Underside of PM8000 meter (DIN rail version).

Feature selection	
Commercial reference number	Description
METSEPM8240	96 x 96 panel mount meter, AC/DC power.
METSEPM8210	96 x 96 panel mount meter, LV DC power.
METSEPM8243	DIN rail mount meter, AC/DC power.
METSEPM8244	DIN rail mount meter with remote display, AC/DC power.
METSEPM82401	MID approved panel mount meter.
Accessories	Description
METSEPM89RD96	Remote display, 3 metre cable, mounting hardware for 30 mm hole (nut & centering pin), mounting hardware for DIN96 cutout (92 x 92 mm) adapter plate
METSEPM89M2600	Digital I/O module (6 digital inputs & 2 relay outputs)
METSEPM89M0024	Analog I/O module (4 analog inputs & 2 analog outputs)
METSEPM8HWK	Replacement hardware kit (connectors, screws, retainer clips, mounting template)

Feature guide		PM8000
General		
Use on LV, MV, and HV systems		b
Current accuracy		0.1 % reading
Voltage accuracy		0.1 % reading
Active energy accuracy		0.2 Class
Number of samples/cycle or sample frequency		256
Instantaneous rms values		
Current, voltage, frequency		b
Active, reactive, apparent power	Total and per phase	b
Power factor	Total and per phase	b
Current measurement range (autoranging)		0.05 - 10 A
Energy values		
Active, reactive, apparent energy		b
Settable accumulation modes		b
Demand values		
Current	Present and max. values	b
Active, reactive, apparent power	Present and max. values	b
Predicted active, reactive, apparent power		b
Synchronization of the measurement window		b
Setting of calculation mode	Block, sliding	b
Power quality measurements		
Harmonic distortion	Current and voltage	b
Individual harmonics	Via front panel and web page	63
	Via EcoStruxure™ software	127
Waveform capture		b
Detection of voltage swells and sags		b
Fast acquisition	1/2 cycle data	b
EN 50160 compliance checking		b
Customizable data outputs (using logic and math functions)		b
Data recording		
Min/max of instantaneous values		b
Data logs		b
Event logs		b
Trending/forecasting		b
SER (Sequence of event recording)		b
Time stamping		b
GPS synchronization (+/- 1 ms)		b
Memory (in Mbytes)		512
Display and I/O		
Front panel display		b
Wiring self-test		b
Pulse output		1
Digital or analog inputs(max)		27 digital 16 analog
Digital or analog outputs (max, including pulse output)		1 digital 8 relay 8 analog
Communication		
RS-485 port		1
Ethernet port		2
Serial port (Modbus, ION, DNP3)		b
Ethernet port (Modbus/TCP, ION TCP, DNP3 TCP, DHCP, DNS, IPv4, IPv6, IEC 61850)		b
Ethernet gateway		b
Alarm notification via email		b
HTTP web server with waveform viewer		b
SNMP with custom MIB and traps for alarms		b
SMTP email		b
PTP and NTP time synchronization		b
FTP file transfer		b

PM8000 series

Technical specifications

Electrical characteristics		
Type of measurement		True rms to 256 samples per cycle
Measurement accuracy	Current & voltage	Class 0.2 as per IEC 61557-12
	Active Power	Class 0.2 as per IEC 61557-12
	Power factor	Class 0.5 as per IEC 61557-12
	Frequency	Class 0.02 as per IEC 61557-12
	Active energy	Class 0.2S IEC 62053-22 Class 0.2 IEC 61557-12, ANSI C12.20 Class 0.2
	Reactive Energy	Class 0.5S IEC 62053-24*
	MID Directive	EN 50470-1, EN 50470-1, AnnexB & AnnexD (optional model)
Display refresh rate		1/2 cycle or 1 second
Input-voltage characteristics	Specified accuracy voltage	57 - 400 V L-N / 100 - 690 V L-L
	Impedance	5 MΩ per phase
	Specified accuracy frequency - Frequency	42 to 69 Hz (50/60 Hz nominal)
	Limit range of operation - frequency	20 to 450 Hz
Input-current characteristics	Rated nominal current	1 A (0.2S), 5 A (0.2S) , 10 A (0.2 ANSI)
	Specified accuracy current range	Starting Current: 5 mA Accurate Range: 50 mA - 10 A
	Permissible overload	200 A rms for 0.5s, non-recurring
	Impedance	0.0003 Ω per phase
	Burden	0.01 VA max at 5 A
Power supply AC/DC	AC	90-415 V AC ±10 % (50/60 Hz ±10 %) 90-120 V AC +/- 10% (400 Hz)
	DC	110-415 V DC ±15 % (20-60 V DC ±10 % for PM8210)
	Ride-through time	100 ms (6 cycles at 60 Hz) min., any condition 200 ms (12 cycles at 60 Hz) typ., 120 V AC 500 ms (30 cycles at 60 Hz) typ., 415 V AC
	Burden	Typical: 7.7 W / 16 VA at 230 V (50/60 Hz) Fully optioned: max. 18 W / 40 VA at 415 V (50/60 Hz).
Power supply LV DC	DC	20 to 60 V DC ±10 %
	Burden	Fully optioned: max. 18 W at 18 to 60 V DC
Input/outputs	Meter Base Only	3 digital inputs (30 V AC/60 V DC) 1 form A (KY) solid state digital output (30 V AC/60 V DC, 75 mA).
	Optional	Digital - 6 digital inputs (30 V AC / 60 V DC) wetted + 2 form C relay outputs (250 V AC, 8 A) Analog - 4 analog inputs (4-20 mA, 0-30 V DC) + 2 analog outputs (4-20 mA, 0-10 V DC).
Mechanical characteristics		
Weight		Integrated Display Model 0.581 kg DIN rail mounted Model 0.528 kg IO modules 0.140 kg Remote display 0.300 kg
IP degree of protection		IP 54, UL type 12: Panel mount and Remote display, front. IP 30: Panel mount rear, DIN rail mount, I/O modules.
Excellent quality		ISO 9001 and ISO 14000 certified manufacturing.
Dimensions	Panel mount model	96 x 96 x 77.5 mm
	DIN model	90.5 x 90.5 x 90.8 mm
	Remote display	96 x 96 x 27 mm
	IO modules	90.5 x 90.5 x 22 mm

PM8000 series

Environmental conditions	
Operating temperature	-25 °C to 70 °C
Remote Display Unit	-25 °C to 60 °C
Storage temperature	-40 °C to 85 °C
Humidity rating	5 % to 95 % non-condensing
Installation category	III
Operating altitude (maximum)	3000 m above sea-level
Electromagnetic compatibility	
EMC standards	IEC 62052-11 and IEC 61326-1
Immunity to electrostatic discharge	IEC 61000-4-2
Immunity to radiated fields	IEC 61000-4-3
Immunity to fast transients	IEC 61000-4-4
Immunity to surges	IEC 61000-4-5
Immunity to conducted disturbances	IEC 61000-4-6
Immunity to power frequency magnetic fields	IEC 61000-4-8
Immunity to conducted disturbances, 2-150kHz	CLC/TR 50579
Immunity to voltage dips & interruptions	IEC 61000-4-11
Immunity to ring waves	IEC 61000-4-12
Conducted and radiated emissions	EN 55022, EN 55011, FCC part 15 Class B, EN55011, EN55022 Class B, ICES-003 Class B
Surge withstand Capability (SWC)	IEEE / ANSI C37.90.1
Safety	
Safety Construction	IEC/EN 61010-1 ed.3, CAT III, 400 V L-N / 690 V L-L UL 61010-1 ed.3 and CSA-C22.2 No. 61010-1 ed.3, CAT III, 347 V L-N / 600 V L-L IEC/EN 62052-11, protective class II.
Communication	
Ethernet to serial line gateway	Communicates directly with up to 31 unit load devices.
Web server	Customisable pages, new page creation capabilities, HTML/XML compatible.
Serial port RS-485	Baud rates of 2400 to 115200, pluggable screw terminal connector.
Ethernet port(s)	2x 10/100BASE-TX, RJ45 connector (UTP).
Protocol	Modbus, ION, DNP3, IEC 61850, HTTP, FTP, SNMP, SMTR, DPWS, RSTP, NTR, NTP/SNTP, GPS, IPv4 /IPv6, DHCP protocols.
Firmware characteristics	
High-speed data recording	Down to 1/2 cycle interval burst recording, stores detailed characteristics of disturbances or outages. Trigger recording by a user-defined setpoint, or from external equipment.
Harmonic distortion	Up to 63rd harmonic (127th via Schneider Electric software) for all voltage and current inputs.
Sag/swell detection	Analyse severity/potential impact of sags and swells: magnitude and duration data suitable for plotting on voltage tolerance curves per phase triggers for waveform recording, control.
Disturbance direction detection	Determine the location of a disturbance more quickly and accurately by determining the direction of the disturbance relative to the meter. Analysis results are captured in the event log, along with a timestamp and confidence level indicating level of certainty.
Instantaneous	High accuracy of standard speed (1s) and high-speed (1/2 cycle) measurements, including true rms per phase and total for: voltage, current, active power (kW), reactive power (kvar), apparent power (kVA), power factor, frequency, voltage and current unbalance, phase reversal.
Load profiling	Channel assignments (800 channels via 50 data recorders) configurable for any measurable parameter, including historical trend recording of energy, demand, voltage, current, power quality, or any measured parameter. Trigger recorders based on time interval, calendar schedule, alarm/event condition, or manually.
Trend curves	Historical trends and future forecasts to better manage demand, circuit loading, and other parameters. Provides average, min, max and standard deviation every hour for last 24 hours, every day for last month, every week for last 8 weeks and every month for last 12 months.
Waveform captures	Simultaneous capture of all voltage and current channels, sub-cycle disturbance capture, maximum cycles is 100,000 (16 samples/cycle x 96 cycles, 10 MB memory), max 256 samples/cycle.
Alarms	Threshold alarms: adjustable pickup and dropout setpoints and time delays, numerous activation levels possible for a given type of alarm, user-defined or automatic alarm threshold settings, user-defined priority levels (optional automatic alarm setting).
Advanced Time of Use (TOU)	6 seasons; 3 different day types: weekend, weekday, and holiday; up to 8 tariffs per day type.

PM8000 series

Firmware characteristics (cont.)	
Advanced security	Up to 50 users with unique access rights. Perform resets, time sync, or meter configurations based on user privileges.
Memory	512 MB.
Firmware update	Update via the communication ports.
Display characteristics	
Integrated or Remote display	320 x 240 (1/4 VGA) Color LCD, configurable screens , 5 buttons and 2 LED indicators (alarm and meter status).
Languages	English, French, Spanish, Russian, Portugese, German, Italian, Chinese.
Notations	IEC, IEEE.
The HMI menu includes	
Alarms	Active alarms, historic alarms (50+ alarms).
Basic Reading	Voltage, current, frequency, power summary.
Power	Power summary, demand, power factor.
Energy	Energy total, delivered, received.
Events	Timestamped verbose event log.
Power Quality	EN 50160, harmonics, phasor diagrams.
Inputs/Outputs	Digital inputs, digital outputs, analog inputs, analog outputs.
Nameplate	Model, serial and FW version.
Custom Screens	Build your own metrics.
Setup Menu	Meter setup, communications setup, display setup, date/time/clock setup, alarm setup, language setup, time of use setup, resets, password setup.

PM8000 series parts

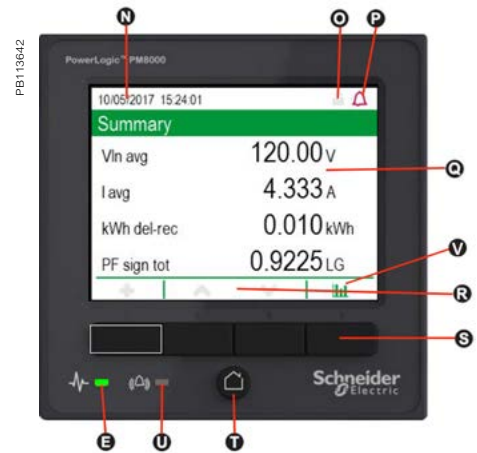
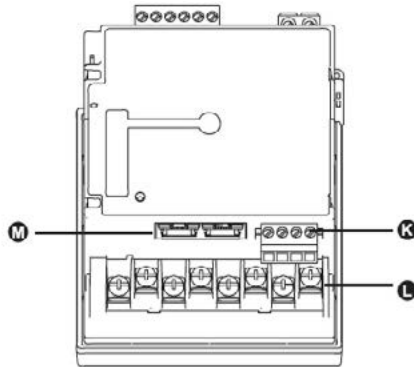
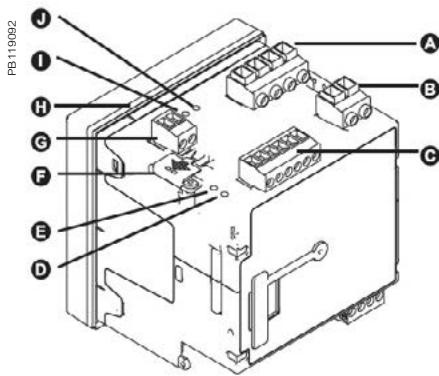

- A** Voltage inputs
- B** Control power
- C** Digital inputs
- D** Revenue lock LED (green)
- E** Status LED (green/red)
- F** Revenue lock switch
- G** Digital output
- H** Sealing gasket
- I** Infrared energy pulsing LED
- J** Energy pulsing LED
- K** RS-485
- L** Current inputs
- M** Ethernet (2)
- N** Date/time
- O** Revenue lock icon

- P** Alarm icon
- Q** Display
- R** Navigation icons
- ▲ Up
- ▼ Down
- ⊙ Select
- ⊗ Cancel
- ⚙ Edit
- ⊕ More
- S** Navigation buttons
- T** Home button
- U** Alarm LED (red)
- V** Bar graph

PM8000 series

PM8000 panel mount meter dimensions

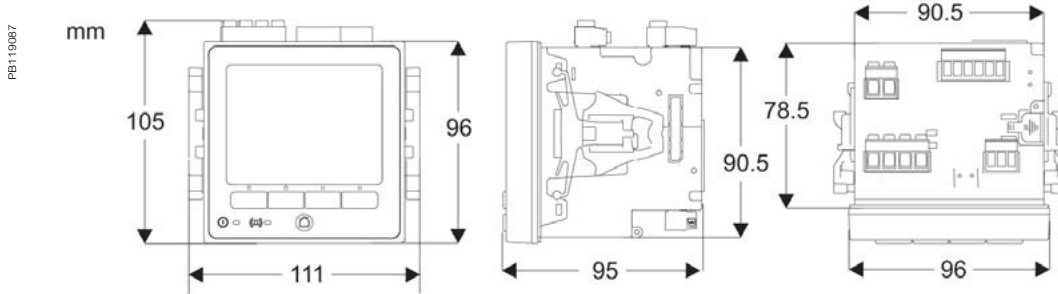

PM8000 DIN rail mount meter dimensions

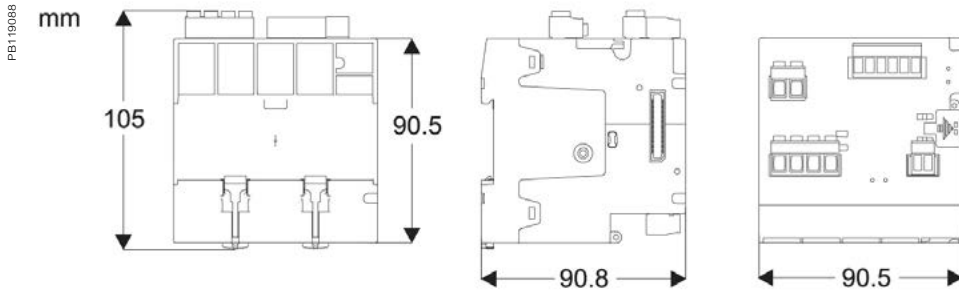

PM8000 remote display dimensions

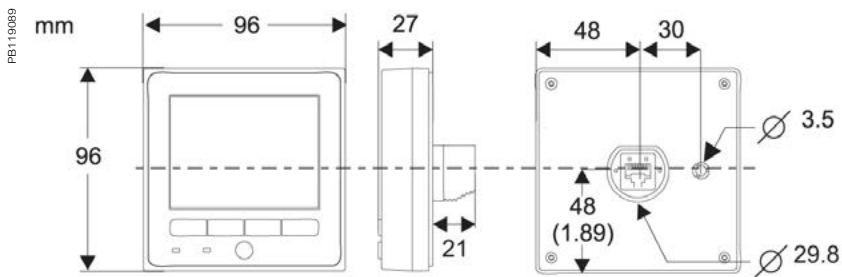

PM8000 with I/O modules dimensions

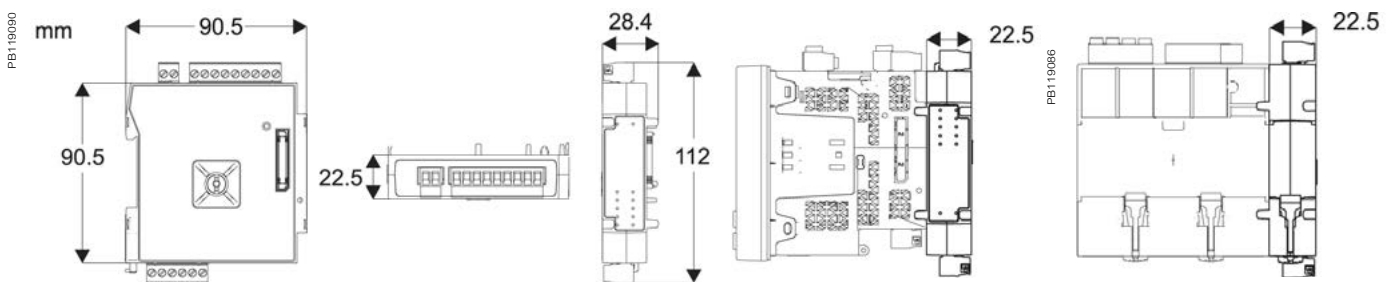

Please see the appropriate **Installation Guide** for accurate and complete information on the installation of this product.

ION9000 Series

The PowerLogic™ ION9000 is your 24/7 power quality expert, providing information, not just data.

This meter offers a comprehensive and industry leading Power Quality Instrument (PQI) performance designation according to IEC 62586-1/-2. It provides the highest accuracy in industry according to ANSI C12.20 Class 0.1 and IEC 62053-22 Class 0.1S. Third-party, lab-verified power quality, accuracy and safety ensure reliable performance and demonstrates the meter's suitability for both supply and demand side applications.

Identify the source of power quality issues faster with our patented Disturbance Direction Detection. Protect your future through highly customizable modularity and field programmability to satisfy any solution. All backed by Schneider Electric's global services and support.

Applications

Ideal for low to high voltage applications in industrial facilities, data centers, infrastructure and other critical power environments.

PB116517



> PowerLogic™ ION9000

The market solution for

Markets that benefit from a solution that includes PowerLogic ION9000 series meters:

- Data centers
- Healthcare facilities
- Semiconductor
- Pharmaceutical & chemical
- Energy industries
- Mining, Minerals, & Metals
- Renewable energy interconnects
- Medium voltage distribution & energy automation

Benefits

- Makes understanding power quality simple which helps operations personnel avoid downtime and increase productivity and equipment life
- Makes energy and power quality data immediately actionable and relevant to operational and sustainability goals

Competitive advantages

- Modular, flexible, patented ION™ programmable technology
- Utility grade energy accuracy
- Patented Disturbance Direction Detection
- Third-party, lab-verified compliance with latest PQ standards
- Onboard pass/fail PQ characterization and assessment according to EN50160 and IEEE519
- Cybersecurity event logging, Syslog protocol, HTTPS, and full control of each communication port

Power management solutions

Schneider Electric provides innovative power management solutions to increase your energy efficiency and cost savings. Maximize electrical network reliability and availability, and optimize electrical asset performance.

Conformity of standards

- ANSI C12.20
- ANSI C37.90.1
- IEC 61000-4-15
- IEC 61000-4-30
- IEC 61010-1
- IEC 61326-1
- IEC 61557-12
- IEC 61850
- IEC 62052-11
- IEC 62052-31
- IEC 62053-22
- IEC 62053-23
- IEC 62053-24
- IEC 62586
- UL 61010-1

Main characteristics



PowerLogic™ ION9000 series meter with RD192 display



PowerLogic™ ION9000 RD192 remote display



PowerLogic™ ION9000 front view

- PQ compliance reporting and basic PQ analysis:
 - Monitors and logs parameters in support of international PQ standards:
 - IEC 61000-4-30 Class A (test methods as per IEC 62586-2).
 - High resolution waveform capture: triggered manually or by alarm. Captured waveforms available directly from the meter via FTP in a COMTRADE format, and viewable in the meter's web interface.
 - Generates onboard PQ compliance reports accessible via onboard web pages:
 - Pass/fail report for IEEE 519 for voltage and current harmonic limits.
 - ITIC (CBEMA) and SEMI curves, with alarm categorization to support further analyses.
 - NEMA Motor Derating curve.
 - Harmonic analysis:
 - THD and TDD per phase, min/max, custom alarming.
 - Individual harmonic magnitudes and angles on voltage and current, up to the 63rd harmonic.
 - Disturbance detection and capture: sag/swell on any current and voltage channel, alarm on disturbance event, waveform capture with per-event information.
 - Patented Disturbance Direction Detection: provides indication of the captured disturbance occurring upstream or downstream of the meter; timestamped results provided in the event log, with degree of certainty of disturbance direction.
- Transient capture of events 20 microseconds or longer in duration on any voltage channel with waveform capture and per-event information.
- Metering precision:
 - IEC 61557-12 PMD/SD/K70/0.2 and PMD/SS/K70/0.2 3000m (Performance Measuring and Monitoring devices (PMD)).
 - Class 0.1S accuracy IEC 62053-22, ANSI C12.20 Class 0.1 (active energy).
 - Industry leading Class 0.5S accuracy for reactive energy (IEC 62053-24).
 - Cycle-by-cycle RMS measurements updated every ½ cycle.
 - Full 'multi-utility' WAGES metering support.
 - Net metering.
 - Anti-tamper protection seals and hardware metrology lock.
- Cybersecurity:
 - Security events logging with Syslog protocol support.
 - HTTPS secure protocol.
 - Ability to enable or disable any communication port and any protocol per port.
 - Anti-tamper protection seals and hardware metrology lock.
 - User accounts with strong passwords.

PB115916



PowerLogic ION9000 with panel mounting adapter

PB115919



PowerLogic ION9000 front with two option modules

PB115920



PowerLogic ION9000 bottom with two option modules

- Used with Schneider Electric’s advanced software tools, provides detailed PQ reporting across entire network:
 - EN 50160 compliance report.
 - IEEE 519 harmonic compliance report.
 - IEC 61000-4-30 report.
 - Power quality compliance summary.
 - Energy reports for consumption analysis and cost management.
 - WAGES dashboards and reports.
 - Display of waveforms and PQ data from all connected meters.
 - Onboard web-based waveform viewer.
 - EcoStruxure Power Events Analysis, including alarm management, sequence of events, and root cause analysis.

- Data and event logging:
 - Onboard data and event logging.
 - 2 GB of standard non-volatile memory.
 - No data gaps due to network outages or server downtime.
 - Min/max log for standard values.
 - 100 user-definable data logs, recording up to 16 parameters at a 1/2 cycle or other user definable interval.
 - Continuous logging or snapshot, triggered by setpoint and stopped after defined duration.
 - Trend energy, demand and other measured parameters.
 - Forecasting via web pages: average, minimum and maximum for the next four hours and next four days.
 - Advanced time-of-use capability.
 - Security/event log: alarm conditions, metering configuration changes, power outages, firmware download, and user login/logout with timestamp.

- Alarming and control:
 - 50+ definable alarms to log critical event data, trigger waveform recording, or perform control function.
 - Trigger on any condition, with 1/2-cycle and 1-second response time.
 - Combine alarms using Boolean logic enabling customization of alarms.
 - Alarm notification via email.
 - In conjunction with Schneider Electric’s EcoStruxure software, alarms, software alarms, and alarm frequency are categorized and trended enabling sequence of events and root cause analyses.

Usability

- On-board, full function web server enables simple web commissioning:
 - Panel and DIN rail mounting options, remote display option.
 - Pluggable connectors.
 - Free setup wizard simplifies meter configuration.
 - Auto-discovery using DPWS (Device Profile Web Services).
 - DHCP for automatic IP address configuration.

- Front panel:
 - Easy to read color graphic display.
 - Simple and intuitive menu navigation with multiple language interface and support.



PowerLogic ION9000 Harmonics display

- Flexible remote communications:
 - Multiple simultaneously operating communication ports and protocols allow interfacing with other automation systems, e.g. waveforms, alarms, billing data, etc. Data can be uploaded for viewing/analysis while other systems access real-time information.
 - Supports: Modbus, ION, DNP3, and IEC 61850.
 - Dual port Ethernet: 2x 10/100BASE-TX; supports IPV4 and IPV6; daisy-chaining capability removes need for additional switches.
 - Create redundant network loop using Rapid Spanning Tree Protocol (RSTP) and managed Ethernet switches.
 - Secure web interface with HTTPS and TLS 1.2 with support for user-provided certificates.
 - Customize TCP/IP port numbers and enable/disable individual ports.
 - RS-485 2-wire connection, up to 115,200 baud, Modbus RTU, ION and DNP3 protocols.
 - Ethernet to serial gateway with Modbus Master functionality, connecting to 31 unit loads of downstream serial Modbus devices. Also supports Modbus Mastering over TCP/IP (Ethernet) network.
 - Full function web server with factory and customizable pages to access real-time and PQ compliance data.
 - Push historical data via email.
 - Advanced network security: Up to 50 configurable user accounts.

- Time synchronization via:
 - Precision network time protocol (PTP) based on IEEE 1588 / IEC 61588.
 - GPS clock (RS-485) or IRIG-B (digital input) to ± 1 millisecond.
 - Network Time Protocol (NTP/SNTP).
 - Automatic time synchronization available through Schneider Electric software server.

Adaptability

- ION™ frameworks are customizable, scalable applications with object-oriented programming that compartmentalizes functions, and increases flexibility and adaptability.
- Applications include: access and aggregate data from Modbus devices on serial port or across the network (Modbus TCP/IP), logging and/or processing data by totaling, unit conversion or other calculations, applying complex logic for alarming or control operations, data visualization via web pages.

Standard meter I/O

- 8 digital status/counter inputs with ± 1 millisecond timestamp.
- 4 solid state digital outputs (Form A) for energy pulsing, interfacing with other systems or control.
- 2 Form C relay outputs for control applications.

Modular I/O options

- Optional expansion modules.
- Up to 4 modules per meter.

Option modules include:

- Digital module:
 - 6 digital status/counter inputs.
 - 2 Form C relay outputs, 250 V AC, 8 A.
- Analog module:
 - 4 analog inputs (4-20 mA; 0-30 V).
 - 2 analog outputs (4-20 mA; 0-10 V) for interfacing with building management sensors and systems.

ION9000 series

Feature guide

General
Use on LV, MV, and HV systems
Current accuracy: 0.1 % reading
Voltage accuracy: 0.1 % reading
Active energy accuracy: 0.1 Class
Number of samples/cycle or sample frequency: 1024
Instantaneous rms values
Current, voltage, frequency
Active, reactive, apparent power: Total and per phase
Power factor: Total and per phase
Energy values
Active, reactive, apparent energy
Settable accumulation modes
Demand values
Current: Present and max. values
Active, reactive, apparent power: Present and max. values
Predicted active, reactive, apparent power
Synchronization of the measurement window
Setting of calculation mode: Block, sliding
Power Quality measurements
Harmonic distortion: Current and voltage
Individual harmonics: via front panel and web page: 63 via EcoStruxure™ software: 127
Waveform capture
Detection of voltage swells and sags
Fast acquisition: 1/2 cycle data
EN 50160 compliance checking
Customizable data outputs (using logic and math functions)
IEEE 519 compliance checking
Data recording
Min/max of instantaneous values
Data logs
Event logs
Trending/forecasting
SER (Sequence of event recording)
Time stamping
GPS synchronization (± 1ms)
Memory: 2000 MB
Display and I/O
Front panel display, 2 options: 96 mm & 192 mm
Pulse output: 2
Digital or analog inputs(max): 32 digital, 16 analog
Digital or analog outputs (max, including pulse output): 4 digital, 10 relay, 8 analog
Communication
RS-485 port(s): 2
Ethernet port(s): 2x 10/100BASE-TX, RJ45 connector, CAT5/5e/6/6a cable
Serial port protocols (Modbus, ION, DNP3)
Ethernet port protocols (Modbus/TCP, ION TCP, DNP3 TCP, DHCP, DNS, IPv4, IPv6, IEC 61850)
Ethernet gateway
Alarm notification via email
HTTP/HTTPS web server with waveform viewer
SNMP with custom MIB and traps for alarms
SMTP email
PTP and NTP time synchronization
FTP file transfer

ION9000 series

Technical specifications

Electrical characteristics

Type of measurement		True rms to 1,024 samples per cycle
Measurement accuracy	Current & voltage	Class 0.1 as per IEC 61557-12
	Active Power	Class 0.1 as per IEC 61557-12
	Power factor	Class 0.5 as per IEC 61557-12
	Frequency	Class 0.02 as per IEC 61557-12
	Active energy	Class 0.1S IEC 62053-22 Class 0.1 IEC 61557-12 Class 0.1 ANSI C12.20
	Reactive Energy	Class 0.5S IEC 62053-24
Display refresh rate		HMI display updated once per second; data refresh rate 1/2 cycle or 1 second
Input-voltage characteristics	Specified accuracy voltage	57 - 400 V L-N / 100 - 690 V L-L
	Impedance	5 MΩ per phase
	Specified accuracy frequency	42 to 69 Hz (50/60 Hz nominal)
	Limit range of operation - frequency	20 to 450 Hz
Input-current characteristics	Rated nominal current	1 A (0.1S), 5 A 1 A (0.1S), 5 A (0.1S); current class 2, 10, 20 A (0.1 ANSI)
	Specified accuracy current range	Starting Current: 1 mA (no accuracy) Accurate Range: 10 mA - 20 A
	Permissible overload	500 A rms for 1.0s
	Impedance	0.0003 Ω per phase
	Burden	0.01 VA max at 5 A
Power supply AC/DC	AC	90-480 V AC ±10 % (50/60 Hz ±10 %) 90-120 V AC ±10% (400 Hz)
	DC	110-480 V DC ±15 %
	Ride-through time (Values for meters with no optional accessories)	100 ms (5 cycles at 50/60 Hz) typ., 120 V AC 400 ms (20 cycles at 50/60 Hz) typ., 240 V AC 1,200 ms (60 cycles at 50/60 Hz) typ., 480 V AC
	Burden	Typical: 16.5 W / 38 VA at 480 V (50/60 Hz) Fully optioned: max. 40 W / 80 VA at 480 V (50/60 Hz).
Input/outputs	Meter base Only	8 digital inputs (30 V AC/60 V DC) 4 Form A (KY) solid state digital output (30 V AC/60 V DC, 75 mA) 2 Form C relays (8 A at 250 V AC, 5 A at 24 V DC)
	Optional	Digital - 6 digital inputs (30 V AC / 60 V DC) wetted + 2 Form C relay outputs (250 V AC, 8 A) Analog - 4 analog inputs (4-20 mA, 0-30 V DC) + 2 analog outputs (4-20 mA, 0-10 V DC).
Mechanical characteristics		
Weight		DIN rail mount meter 1.5 kg I/O modules 0.140 kg Touchscreen display 0.300 kg
IP degree of protection		IP 65, UL type 12: Panel mount and touchscreen display, front. IP 30: Panel mount rear, DIN rail mount, I/O modules.
Excellent quality		ISO 9001 and ISO 14000 certified manufacturing.
Dimensions	Panel mount	160 x 160 x 135.3 mm
	DIN rail mount meter	160 x 160 x 135.3 mm
	Color remote display (2 options)	197 x 175 x 27.5 mm touchscreen 96 x 96 x 27 mm pushbutton
	I/O modules	90.5 x 90.5 x 22 mm
	Touchscreen display(s)	192 mm and 96 mm

ION9000 series

Environmental conditions	
Operating temperature	-25 to 70 °C
Remote Display Unit	-25 to 60 °C
Storage temperature	-40 to 85 °C
Humidity rating	5 to 95 % non-condensing
Installation category	III
Operating altitude (maximum)	3,000 m above sea-level
Electromagnetic compatibility	
EMC standards	IEC 62052-11, IEC 61326-1, IEC 61000-6-5
Immunity to electrostatic discharge	IEC 61000-4-2
Immunity to radiated fields	IEC 61000-4-3
Immunity to fast transients	IEC 61000-4-4
Immunity to surges	IEC 61000-4-5
Immunity to conducted disturbances	IEC 61000-4-6
Immunity to power frequency magnetic fields	IEC 61000-4-8
Immunity to conducted disturbances, 2-150kHz	CLC/TR 50579
Immunity to voltage dips & interruptions	IEC 61000-4-11
Immunity to ring waves	IEC 61000-4-12
Conducted and radiated emissions	EN 55011 and EN 55032 Class B, FCC part 15 Class B, ICES-003 Class B
Surge withstand Capability (SWC)	IEEE/ANSI C37.90.1
Safety	
Safety Construction	IEC/EN 61010-1 ed.3, CAT III, 400 V L-N / 690 V L-L UL 61010-1 ed.3 and CSA-C22.2 No. 61010-1 ed.3, CAT III, 347 V L-N / 600 V L-L IEC/EN 62052-31, protective class II.
Communication	
Ethernet to serial line gateway	Communicates directly with up to 31 serial devices.
Web server	Customizable pages, new page creation capabilities, HTML/XML compatible.
Serial port RS-485	2x, Baud rates of 2,400 to 115,200, pluggable screw terminal connector.
Ethernet port(s)	2x 10/100BASE-TX, RJ45 connector, CAT5/5e/6/6a cable.
Protocol	HTTPS, FTP, SNMP, SMT, DPWS, RSTP, PTR, NTP/SNTP, GPS, Syslog, DHCP, IPv4, IPv6.
Firmware characteristics	
High-speed data recording	Down to 1/2 cycle interval recording, stores detailed characteristics of disturbances or outages. Trigger recording by a user-defined setpoint, or from external equipment.
Harmonic distortion	Up to 63rd harmonic (511th via Schneider Electric EcoStruxure software) for all voltage and current inputs.
Sag/swell detection	Analyze severity/potential impact of sags and swells: magnitude and duration data suitable for plotting on voltage tolerance curves per phase triggers for waveform recording.
Disturbance direction detection	Determine the location of a disturbance more quickly and accurately by determining the direction of the disturbance relative to the meter. Results are captured in the event log, along with a timestamp and confidence level indicating level of certainty.
Detection and capture of transients	As short as 20 µs at 50 Hz (17 µs at 60 Hz)
Instantaneous	High accuracy of standard speed (1s) and high-speed (1/2 cycle) measurements, including true rms per phase and total for: voltage, current, active power (kW), reactive power (kvar), apparent power (kVA), power factor, frequency, voltage and current unbalance, phase reversal.
Load profiling	Channel assignments (1600 channels via 100 recorders) configurable for any measurable parameter, including historical trend recording of energy, demand, voltage, current, power quality, or any measured parameter. Trigger recorders based on time interval, calendar schedule, alarm/event condition, or manually.
Trend curves	Historical trends and future forecasts to better manage demand, circuit loading, and other parameters. Provides average, min, max, and standard deviation every hour for last 24 hours, every day for last month, every week for last 8 weeks and every month for last 12 months.
Waveform captures	Simultaneous capture of voltage and current channels, sub-cycle disturbance captures of 180-cycles @ 1,024 samples/cycle to 7,200-cycles @ 16 sample/cycle, retriggerable.
Alarms	Threshold alarms: adjustable pickup and dropout setpoints and time delays, numerous activation levels possible for a given type of alarm, user-defined or automatic alarm threshold settings, user-defined priority levels (optional automatic alarm setting).
Advanced Time of Use (TOU)	4 seasons; 5 different day types: weekend, weekday, and holiday; up to 4 tariffs per day type.

ION9000 series

Firmware characteristics (cont.)	
Advanced network security	Up to 50 users with unique access rights. Perform resets, time sync, or meter configurations based on user privileges.
Memory	2,000 MB.
Firmware update	Update via the communication ports.
Display characteristics	
96 mm pushbutton display	320 x 240 (1/4 VGA) color LCD, configurable screens , 5 buttons and 2 LED indicators (alarm and meter status).
192 mm touchscreen display	800 x 400 pixels, 177.8 mm (7") Color LCD, +/- 85 degree view angle, sunlight readable, dual capacitive touch, usable when wet or through Class 0 lineman gloves, impact resistant to 5 joules, IP65 rating,
Languages	English, French, Spanish, Russian, Portugese, German, Italian, Chinese.
Notations	IEC, IEEE.
The HMI menu includes	
Alarms	Active alarms, historic alarms (50+ alarms).
Basic reading	Voltage, current, frequency, power summary.
Power	Power summary, demand, power factor.
Energy	Energy total, delivered, received.
Events	Timestamped verbose event log.
Power Quality	EN 50160, IEEE 519, harmonics, phasor diagrams.
Inputs/Outputs	Digital inputs, digital outputs, relay outputs, analog inputs, analog outputs.
Nameplate	Model, serial and FW version.
Custom screens	Build your own metrics.
Setup menu	Meter setup, communications setup, display setup, date/time/clock setup, alarm setup, language setup, time of use setup, resets, password setup.

ION9000 Commercial reference numbers

Commercial reference number	Description
METSEION92030	ION9200 meter, DIN mount, no display, HW kit
METSEION92040	ION9200 meter, DIN mount, 192 mm display, B2B adapter, HW kit
METSEPM89RD96	Remote display, color LCD, 96 x 96 mm
METSERD192	Remote display, color touchscreen, 192 x 192 mm
METSEPM89M2600	I/O module, 2 relay outputs, 6 digital inputs
METSEPM89M0024	I/O module, 2 analog outputs, 4 analog inputs
METSE9HWK	ION9000 meter hardware kit – plugs, terminal guards, spare grounding screw, DIN clips
METSERD192HWK	RD192 remote display hardware kit
METSE9B2BMA	ION9000 B2B adapter
METSE9CTHWK	ION9000 Current Input hardware kit – terminal screws, CT covers
METSE7x4MAK	ION7x50 Mounting Adapter Kit

Contact your Schneider Electric representative for complete ordering information.

ION9000 series

ION9000 meter dimensions

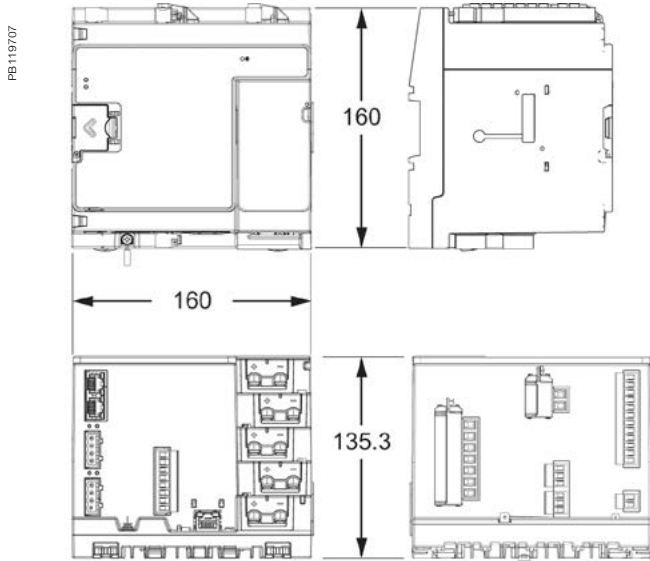

ION9000 mounting template

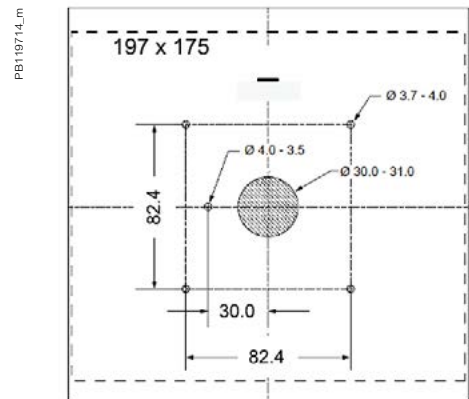

ION9000 back-to-back (B2B) dimensions

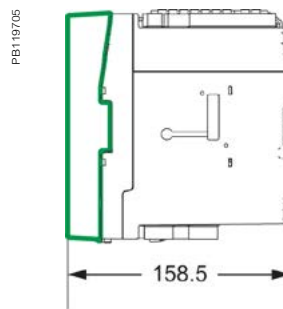

ION9000 192 mm display dimensions

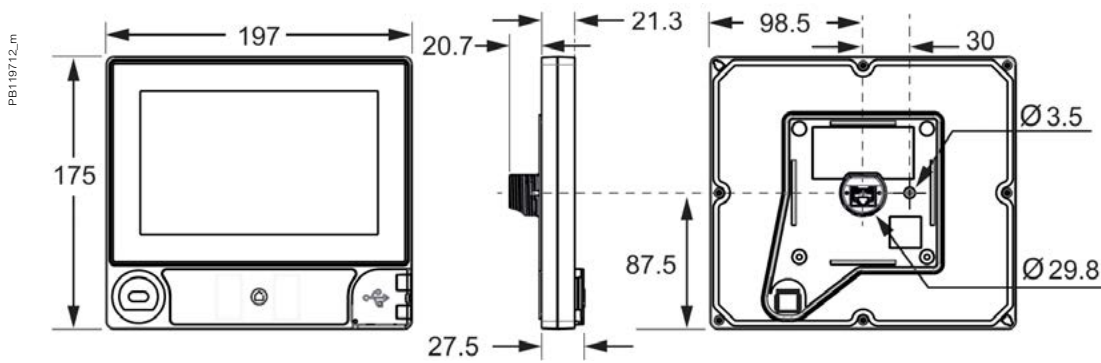

ION9000 96 mm display dimensions

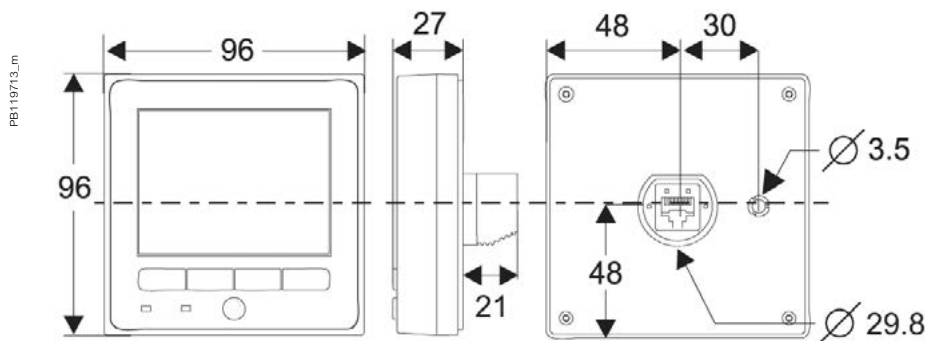

Please refer to ION9000 Series Meter Installation Sheet for accurate and complete information on the installation of this product.

ION9000 series

ION9000 meter DIN rail dimensions

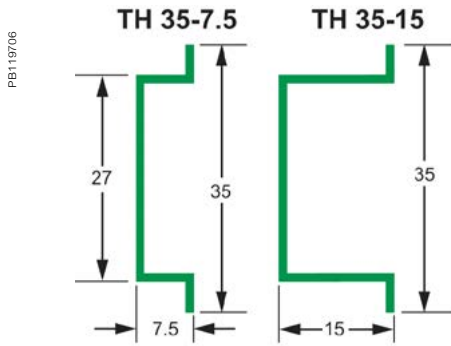

ION7x50 mounting adapter dimensions

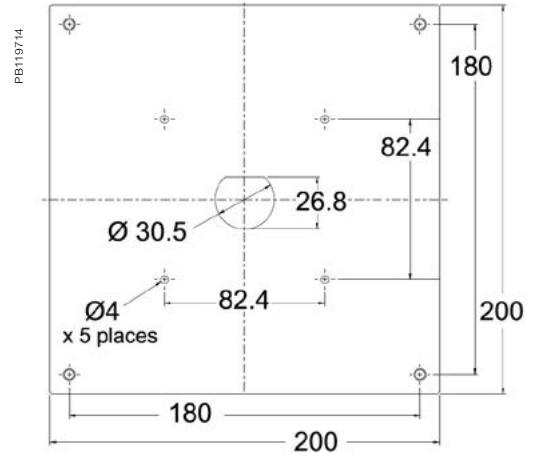

ION9000 meter click installation

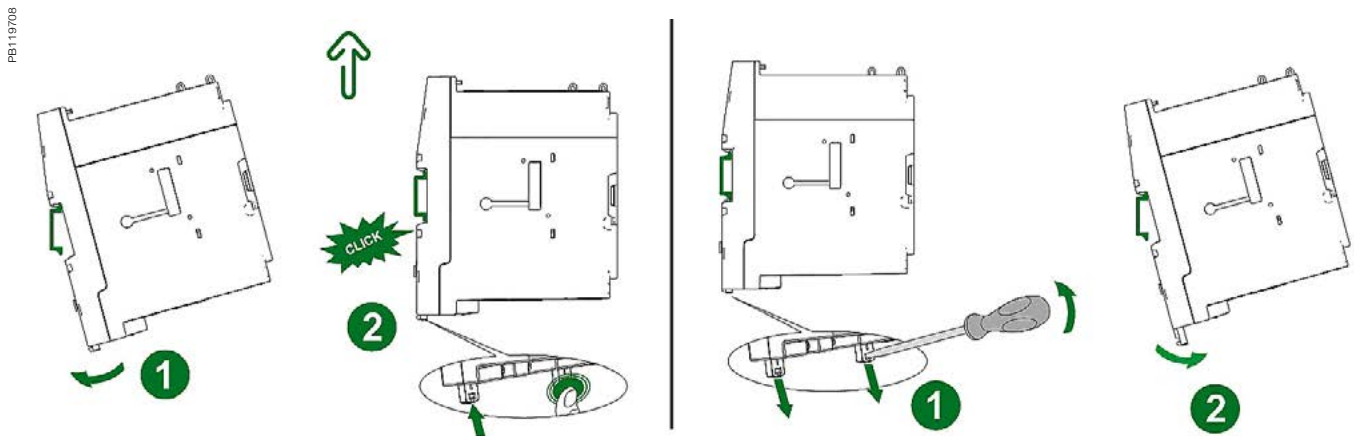



Advanced utility metering



Overview

Power quality and revenue meters are designed for utility network monitoring, e.g. transmission and distribution network monitoring.

Revenue and power quality meters designed for precision metering at key transmission network inter-ties, distribution substations and service entrances to optimise power reliability and energy efficiency in utility smart grids.

- PowerLogic ION8800



[> Advanced utility metering](#)

ION8800 series

Providing high accuracy and a wide range of features for transmission and distribution metering, the PowerLogic ION8800 advanced revenue and power quality meter has the flexibility to change along with your needs. The meter provides the tools necessary to:

- Manage energy procurement and supply contracts
- Perform network capacity planning and stability analysis
- Monitor power quality compliance, supply agreements, and regulatory requirements

Applications

- Transmission and distribution metering
- Revenue metering
- Extensive power quality monitoring and analysis
- Power quality compliance monitoring
- Digital fault recording
- Instrument transformer correction



> [Advanced utility metering](#)

The solution for

Markets that can benefit from a solution that includes PowerLogic ION8800 series meters:

- Transmission networks
- Distribution network

Benefits

- Reduce operations costs
- Improve power quality
- Improve continuity of service

Competitive advantages

- Integrated into existing wholesale settlement system
- Able to use EcoStruxure™ software for data analysis or share operation data with SCADA systems through multiple communication channels and protocols
- Transformer/line loss compensation
- Instrument transformer correction

Power management solutions

Schneider Electric provides innovative power management solutions to increase your energy efficiency and cost savings, maximise electrical network reliability and availability, and optimise electrical asset performance.

Conformity of standards

- IEC 62053-22/23
- IEC 61000-4-3
- IEC 61000-4-30
- IEC 61000-4-4
- EN 50160
- IEC 61000-4-5
- IEC 61000-4-7
- IEC 61000-4-6
- IEC 61000-4-15
- IEC 61000-4-12
- IEEE 1159
- CISPR 22
- IEEE 519
- IEC 62052-11
- IEC 61000-4-2
- IEC 60950

Main characteristics

- IEC 19-inch rack mount design to DIN 43862 standard
 - Use Essalec connectors with common measurement and energy pulsing pin-out to easily retrofit into existing systems.
- Accurate metering
 - Interconnection points on medium, high, and ultra-high voltage networks are in compliance with IEC 62053-22/23 Class 0,2S.
- Power quality compliance monitoring
 - Monitor compliance with international quality-of-supply standards (IEC 61000-4-30 Class A/S, EN50160, IEC 61000-4-7, IEC 61000-4-15, IEEE 1159, IEEE 519).
- Power quality summary
 - Consolidate power quality characteristics into easily viewable reports indices.
- Digital fault recording
 - Capture voltage and current channels simultaneously for sub-cycle disturbances.
- Complete communications
 - Use the IEC1107 optical port or the optional communications module that supports concurrent Ethernet, serial, and modem communications.
- Multiple tariffs and time-of-use
 - Apply tariffs and seasonal rate schedules to measure energy and demand values for time periods with specific billing requirements.
- Alarms and I/O functions
 - Use up to 65 setpoints for single/multi-condition alarms and I/O functions with response times down to 1/2 cycle.
- Alarm notification via email
 - High-priority alarms, data logs sent directly to the user's PC. Instant notification of power quality events by email.
- Software integration
 - Easily integrate the meter with EcoStruxure™ Power Monitoring Expert, EcoStruxure™ Power SCADA Operation, or other utility software; MV-90, Pacis and third-party SCADA packages.
- Transformer/line loss compensation
 - Compensate for system losses in real time directly in the meter.
- Instrument transformer correction
 - Save money and improve accuracy by correcting for less accurate transformers.

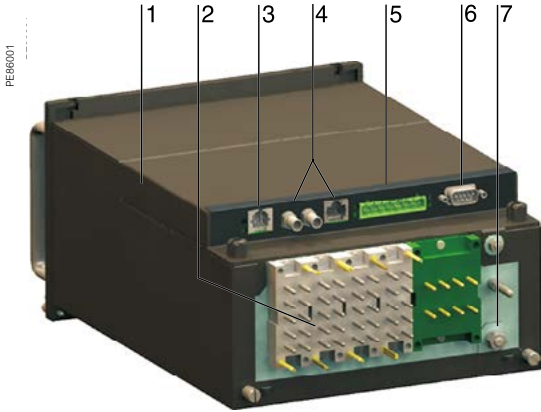

PowerLogic ION8800 meter

- 1 Optional communications module.
- 2 Essailec connectors.
- 3 Internal modem.
- 4 Optional Ethernet communications.
- 5 Selectable RS-485 serial port.
- 6 Selectable RS-232 or RS-485 serial port.
- 7 Ground terminal.

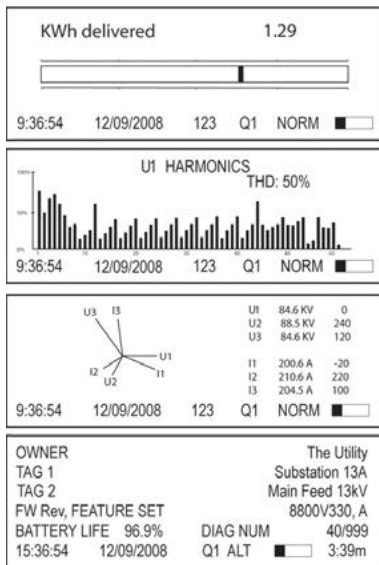

Display screen examples: KWh disk simulator, voltage harmonics histogram, phasor diagram, and name plate 1.

Selection guide

	ION8800A ION8800B	ION8800C
General		
Use on LV, MV and HV systems	b	b
Current accuracy	0.1 %	0.1 %
Voltage accuracy	0.1 %	0.1 %
Power accuracy	0.2 %	0.2 %
Samples/cycle	1024	1024
Instantaneous rms values		
Current, voltage, frequency (Class 0,2S)	b	b
Active, reactive, apparent power Total and per phase	b	b
Power factor Total and per phase	b	b
Current measurement range	0.001 - 10 A	0.001 - 10 A
Current measurement range	0.001 - 10 A	0.001 - 10 A
Energy values		
Active, reactive, apparent energy	b	b
Settable accumulation modes	b	b
Demand values		
Current	b	b
Active, reactive, apparent	b	b
Predicted active, reactive, apparent	b	b
Demand modes (block, sliding, thermal, predicted)	b	b
Power quality measurements		
Detection of voltage dips (sags) and swells	10 ms	10 ms
Symmetrical components: zero, positive, negative	b	-
Transient detection, microseconds (50 Hz)	20 ⁽¹⁾	20 ⁽¹⁾
Harmonics: individual, even, odd, total up to	63 rd	63 rd
Harmonics: magnitude, phase and inter-harmonics	50 th	40 th
EN 50160 compliance	b	
IEC 61000-4-30 class A	b	
IEC 61000-4-30 class S	b ⁽²⁾	
IEC 61000-4-15 (Flicker)	b	-
Configurable for IEEE 519 - 1992, IEEE1159-1995	b ⁽¹⁾	-
Programmable (logic and math functions)	b	b
Data recording		
Min/max logging for any parameter	b	b
Historical logs Maximum # of records	960 ⁽¹⁾ 800 ⁽²⁾	80
Waveform logs Maximum # of records	96 ⁽¹⁾	64
Timestamp resolution in seconds	0.001	0.001
Setpoints, minimum response time	½ cycle	½ cycle
Number of setpoints	65	65
GPS time synchronisation (IRIG-B)	b	b
Could add transient logs. COMTRADE fault records.	b	b
User configurable log memory	10 MB	10 MB
Display and I/O		
Front panel display	b	b
Active/reactive energy pulser, LED and IEC 1107 style port	b	b
Digital pulse outputs, optional Solid state Form A	8	8
Digital pulse outputs Solid state Form C	4	4
Alarm relay output Form C	1	1
Digital inputs (optional)	3	3
Communications		
RS-232/485 port	1	1
RS-485 port	1	1
Ethernet port	1	1
IEC 1107 optical port	1	1
Internal modem	1	1
3-port DNP 3.0 through serial, modem, Ethernet and I/R ports	b	b
Modbus RTU master / slave (serial, modem and I/R ports)	b / b	- / b
Modbus TCP master / slave (via Ethernet port)	b / b	- / b
DLMS RS-485 port or Ethernet	b	b
Data transfer between Ethernet and RS-485 (EtherGate)	b	b
Data transfer between internal modem, RS-485 (ModemGate)	b	b
Alarms, single or multi-condition	b	b
Alarm notification & logged data via email	b	b
Embedded web server (WebMeter)	b	b

(1) ION8800A only.

(2) ION8800B only.

Part numbers			
Item	Code	Description	
1	Model	M8800	ION8800 IEC/DIN 43862 19" rack mount energy and power quality meter.
2	Feature Set	A	Class A power quality analysis, waveforms and transient capture with 1024 samples/cycle.
		B	Energy meter Class S EN50160 power quality monitoring.
		C	Basic tariff/energy revenue meter with sag/swell monitoring.
3	Memory/Form Factor	1	10 MB logging memory, Essailec connectors.
		2	5 MB logging memory, Essailec connectors, with IEC61850 protocol
4	Current Inputs	C	(I1-I3): Configured for 5 A nominal, 10 A full scale, 14 A fault capture, 0.001 A starting current.
		E	(I1-I3): Configured for 1 A nominal, 10 A full scale, 14 A fault capture, 0.001 A starting current.
5	Voltage Inputs	0	(V1-V3): Autoranging (57-288 VAC L-N or 99-500 VAC L-L)
6	Power Supply	B	Single phase power supply: 85-240 VAC ±10% (47-63 Hz) or 110-270 VDC.
7	System Frequency	5	Calibrated for 50 Hz systems.
		6	Calibrated for 60 Hz systems.
8	Communications module (field serviceable)	Z0	No communications module - meter includes Base Onboard I/O and comms (see below for details).
		A0	Standard communications: 1 RS 232/RS-485 port, 1 RS-485 port (COM2) ⁽¹⁾ .
		C1	Standard communications plus 10BASE-T Ethernet (RJ45), 56 k universal internal modem (RJ11).
		D1	Standard communications plus 10BASE-T/100BASE-TX Ethernet (RJ45) / 10Base-FL/100BASE-FX Ethernet Fiber, 56 k universal internal modem (RJ11)
		E0	Standard communications plus 10BASE-T/100BASE-TX Ethernet (RJ45).
		F0	Standard communications plus 10BASE-T/100BASE-TX Ethernet (RJ45) / 10Base-FL/100BASE-FX (ST male Fiber Optic connection).
		M1	Standard communications plus 56k universal internal modem (RJ11).
9	Onboard I/O and communications (not field serviceable, part of base unit)	A	Base option AND 8 Form A digital outputs ⁽²⁾ , 1 RS-485 (COM2) port ⁽¹⁾ .
		B	Base Option AND 8 Form A digital outputs ⁽²⁾ , 3 digital inputs (20-56 VDC/AC).
		C	Base Option AND 8 Form A digital outputs ⁽²⁾ , 3 digital inputs (80-280 VDC/AC).
		D	Base Option AND 1 IRIG-B time sync port ⁽²⁾ , 1 RS-485 port (COM2), 3 digital inputs (20-56 V DC/AC) ⁽¹⁾ .
		E	Base Option AND 1 IRIG-B time sync port ⁽²⁾ , 1 RS-485 port (COM2), 3 digital inputs (80-280 V DC/AC) ⁽¹⁾ .
10	Security	0	Password protected, no security lock.
		1	Password protected with security lock enabled.
11	Special Order	A	None.
		C	Tropicalisation treatment applied.

Example product part number.

- 1 Model.
- 2 Feature set.
- 3 Memory / form factor.
- 4 Current Inputs.
- 5 Voltage inputs.
- 6 Power supply.
- 7 System frequency.
- 8 Communications.
- 9 Onboard inputs/outputs.
- 10 Security.
- 11 Special order.

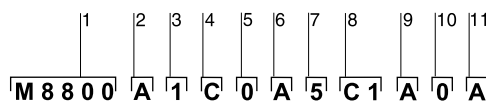

(1) Channel COM2 is available on the port at the back of the meter OR on the Comm Module (if installed). You must select which connectors your communications wiring is connected to during meter setup.

(2) All Onboard I/O and Comms (Base Option) options include: 4 Form C solid-state digital outputs, 1 Form C mechanical relay output, one IEC 1107 optical communications port, two IEC 1107 style optical pulsing ports.

ION8800 Accessories

Ordering reference	Communication Card for ION8800
P880CA0A	Std. comms: 1 RS-232/RS-485 port, **1 RS-485 port (COM2)
P880CA0C	Std. comms: 1 RS-232/RS-485 port, **1 RS-485 port (COM2), tropicalisation treatment applied
P880CC1A	Std. comms AND 10/1000BASE-TX Ethernet (RJ45), 56k universal internal modem (RJ11)
P880CC1C	Std. comms AND 10/1000BASE-TX Ethernet (RJ45), 56k universal internal modem (RJ11), tropicalisation treatment applied
P880CD1A	Std. comms AND 10/1000BASE-TX Ethernet (RJ45) / 10/100BASE-FX Ethernet Fiber, 56k universal internal modem (RJ11)
P880CD1C	Std. comms AND 10/1000BASE-TX Ethernet (RJ45) / 10/100BASE-FX Ethernet Fiber, 56k universal internal modem (RJ11), tropicalisation treatment applied
P880CE0A	Std. comms AND 10/1000BASE-TX Ethernet (RJ45)
P880CE0C	Std. comms AND 10/1000BASE-TX Ethernet (RJ45), tropicalisation treatment applied
P880CF0A	Std. comms AND 10/1000BASE-TX Ethernet (RJ45) / 10/100BASE-FX (ST Fiber Optic connection)
P880CF0C	Std. comms AND 10/1000BASE-TX Ethernet (RJ45) / 10/100BASE-FX (ST Fiber Optic connection), tropicalisation treatment applied
P880CM1A	Std. comms AND 56k universal internal modem (RJ11)
P880CM1C	Std. comms AND 56k universal internal modem (RJ11), tropicalisation treatment applied
Ordering reference	ION8800 related items
BATT-REPLACE-8XXX	Replacement batteries for the ION8600 or ION8800, quantity 10
RACK-8800-RAW	IEC/DIN 34862 19" Rack with female mating voltage/current and I/O blocks unassembled.
IEC-OPTICAL-PROBE	IEC 61107 compliant Optical Probe (DB-9) for use with ION8800 meters

PE66007_C



Optional ION8800 communications module

ION8800 series

Technical Specification		
Electrical characteristics		
Type of measurement	True rms 1024 samples per cycle	
Measurement accuracy	Current and voltage	0.1 %
	Power	0.2 %
	Frequency	±0.005 Hz
	Power factor	0.1%
	Energy	IEC 62053-22/23 Class 0.2 S
Data update rate	½ cycle or 1 second	
Input-voltage characteristics	Inputs	U1, U2, U3, Uref
	Measurement range	57-288 L-N V AC rms (99-500 L-L V AC rms)
	Dielectric withstand	3320 V AC rms
	Impedance	5 MΩ /phase (phase-Uref/Ground)
Input-current characteristics	Rated nominals	5 A, 1 A, 2 A
	Permissible overload	200A rms for 0.5s, non-recurring (IEC 62053-22)
	Impedance	10 mΩ /phase
	Burden	0.01 VA per phase (1A), 0.25 VA per phase (5 A)
Power supply	AC	85 - 240 V AC (+/- 10 %), 47-63 Hz
	DC	110 - 270 V DC (+/- 10 %)
	Burden	Typical (without comm module): 13 VA, 8 W Typical (with comm module): 19 VA, 12 W Max (without comm module): 24 VA, 10 W Max (with comm module): 32 VA, 14 W
	Ride-through time	Typical: 0.5 s to 5 s depending on configuration Min: 120 ms (6 cycles @ 50 Hz)
	Dielectric withstand	2000 V AC
Input/outputs	Mechanical alarm relay	1 Form C digital output (250 V AC / 125 V DC, 1 A AC / 0.1 A DC max)
	Digital outputs (Form C)	4 Solid state relay outputs (210 V AC / 250 V DC) 100 mA AC/DC
	Digital outputs (Form A)	8 Solid state relay outputs (210 V AC / 250 V DC) 100 mA AC/DC
	Digital inputs	3 Solid state digital inputs (low-voltage inputs 15 to 75 V AC/DC; high-voltage inputs 75 to 280 V AC/DC; 3 mA max.)
	Pulse rate	20 Hz maximum
Mechanical characteristics		
Weight	6.0 kg (6.5 kg with optional communications module)	
IP degree of protection (IEC 60529)	IP51	
Dimensions	202.1 x 261.51 x 132.2 mm	
Environmental conditions		
Mounting location	Indoor	
Maximum altitude	2000 metres above sea-level	
Limit range of operation	-25 °C to 70 °C	
Specified operating temperature	-10 °C to 45 °C (as per 62052-11)	
Display operating range	-10 °C to 60 °C	
Storage temperature	-25 °C to 70 °C	
Humidity rating	5 to 95 % RH non-condensing	
Pollution degree	2	
Installation category	Power supply (II) Metering inputs (III)	
Electromagnetic compatibility		
Electrostatic discharge	IEC 61000-4-2	
Immunity to radiated fields	IEC 61000-4-3	
Immunity to fast transients	IEC 61000-4-4	
Immunity to surge waves	IEC 61000-4-5	
Conducted immunity	IEC 61000-4-6	
Damped oscillatory waves immunity	IEC 61000-4-12	
Conducted and radiated emissions	CISPR 22 (class B)	
Safety		
Europe	As per IEC 62052-11	
International	As per IEC 60950	

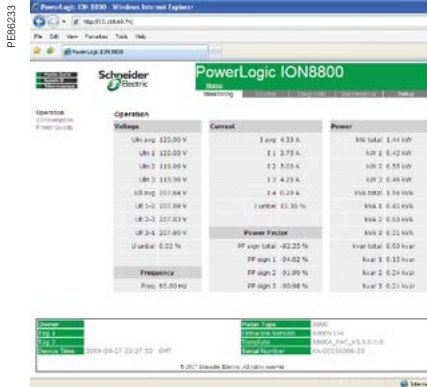
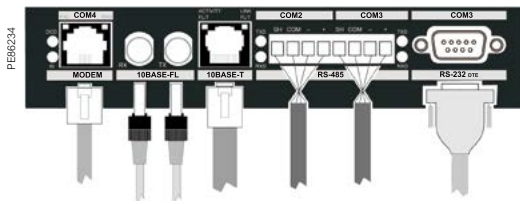

Ports on the optional communications module.

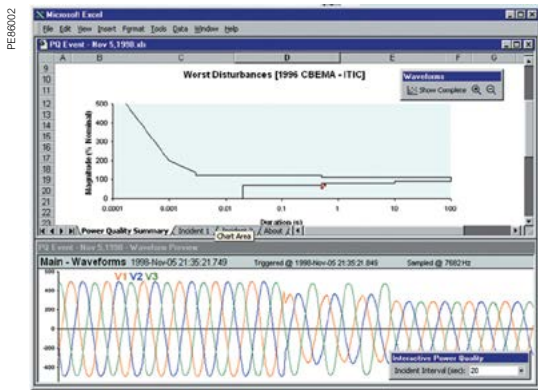

Example embedded page showing realtime values.

Technical Specification

Communication	
IEC 1107 optical port	2/4 wires, up to 19200 baud
RS-485 port	Up to 57600 baud, direct connection to a PC or modem, protocols: ION, Modbus RTU, Modbus Master, DNP 3.0, GPSTRUE TIME/DATUM, DLMS
Communications module (optional)	
RS-232/485 port	300 - 115,200 baud (RS-485 limited to 57,600 baud); protocols: same as RS-485 port
Internal modem port	300 baud - 56000 baud, RJ11 connector
Ethernet port	10/100BASE-TX, RJ45 connector, 100 m link; protocols: DNP TCP, ION, Modbus TCP, Modbus Master, DLMS, IEC 61850
Fiber-optic Ethernet link	10/100BASE-FX, ST connector, 1300 nm, FO multimode with gradient index 62.5/125 µm or 50/125 µm, 2000 m link; protocols: same as Ethernet port
EtherGate	Communicates directly with up to 62 slave devices via available serial ports
ModemGate	Communicates directly with up to 31 slave devices
Firmware characteristics	
High-speed data recording	Up to ½-cycle interval burst recording, stores detailed characteristics of disturbances or outages Trigger recording by a user-defined setpoint, or from external equipment.
Harmonic distortion	Up to 63 rd harmonic for all voltage and current inputs
Dip/swell detection	Analyse severity/potential impact of sags and swells: magnitude and duration data suitable for plotting on voltage tolerance curves per phase triggers for waveform recording or control operations
Instantaneous	High accuracy measurements with 1s or 1/2 cycle update rate for: voltage and current active power (kW) and reactive power (kvar) apparent power (kVA) power factor and frequency voltage and current unbalance phase reversal
Load profiling	Channel assignments (800 channels via 50 data recorders) are configurable for any measureable parameter, including historical trend recording of energy, demand, voltage, current, power quality, or any measured parameter Trigger recorders based on time interval, calendar schedule, alarm/event condition, or manually.
Modbus Master	Master up to 32 slave devices per serial channel and store their data at programmable intervals. Use this data to aggregate and sum energy values and perform complex totaling.
Waveform captures	Simultaneous capture of all voltage and current channels sub-cycle disturbance capture maximum cycles is 214,000 (16 samples/cycle x 96 cycles, 10 MB memory) 1024 samples/cycle
Alarms	Threshold alarms: adjustable pickup and dropout setpoints and time delays, numerous activation levels possible for a given type of alarm user-defined priority levels boolean combination of alarms possible
Advanced security	Up to 50 users with unique access rights. Perform resets, time syncs, or meter configurations based on user privileges.
Transformer correction	Correct for phase / magnitude inaccuracies in current transformers (CTs), potential transformers (PTs)
Memory	5 -10 MB(specified at time of order)
Firmware update	Update via the communication ports
Display characteristics	
Type	FSTN transreflective LCD
Backlight	LED
Languages	English

ION8800 dimensions

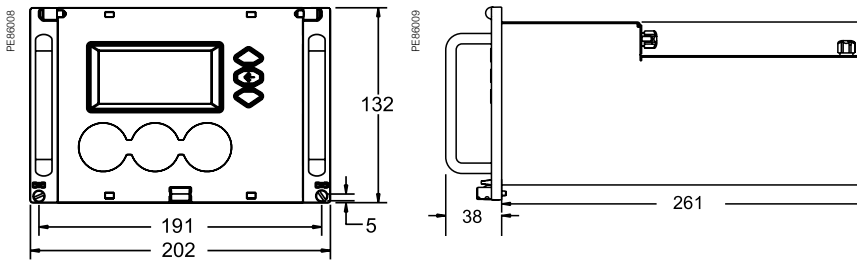

ION8800 Essailec rack dimensions

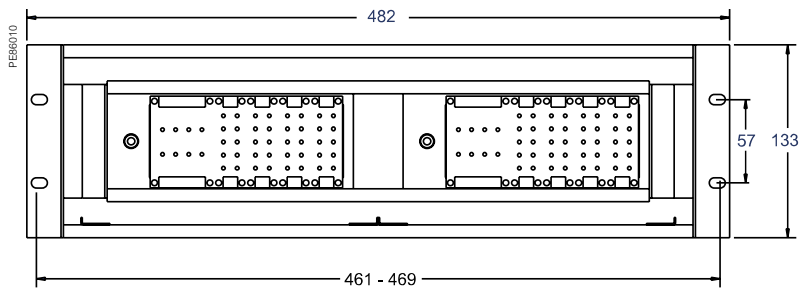

Rack mounting the ION8800

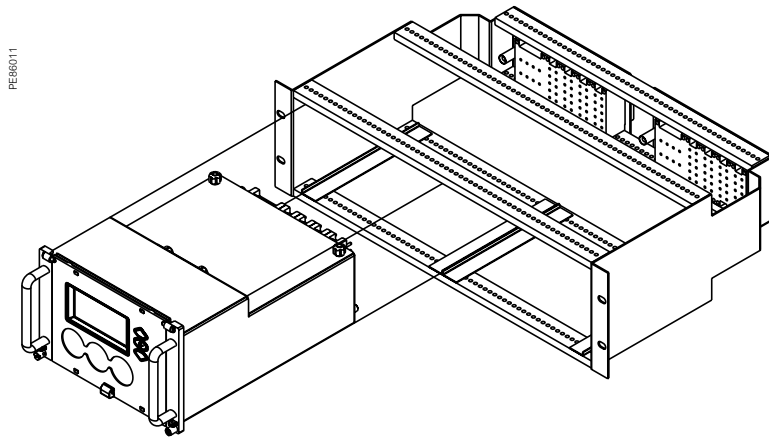

ION8800 communication module dimensions

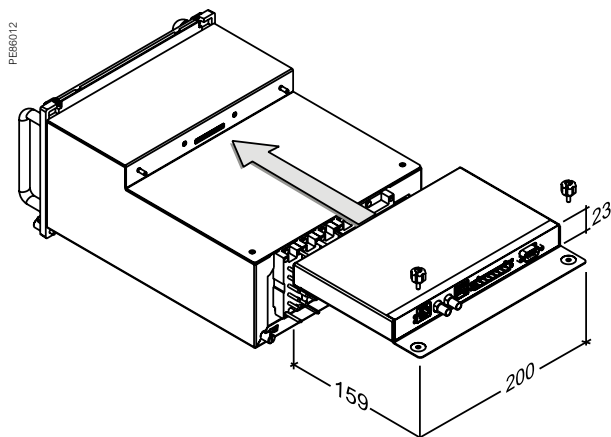

Please see the appropriate **Installation Guide** for accurate and complete information on the installation of this product.



Multi-circuit metering



Overview

This is an integrated solution for monitoring multi-circuits and mains by using a single meter. The meter is designed for use in both new build and retrofit and is used for critical power operations in data centres and energy management in buildings.

The ideal solution for data centre managers, energy or facility managers, engineers and operational executives who are responsible for delivering power to critical applications.

In corporate and hosted data centre facilities, this technology helps you plan and optimise the critical power infrastructure to meet the demands of continuous availability.

- PowerLogic BCPM

PB113085 PE66325

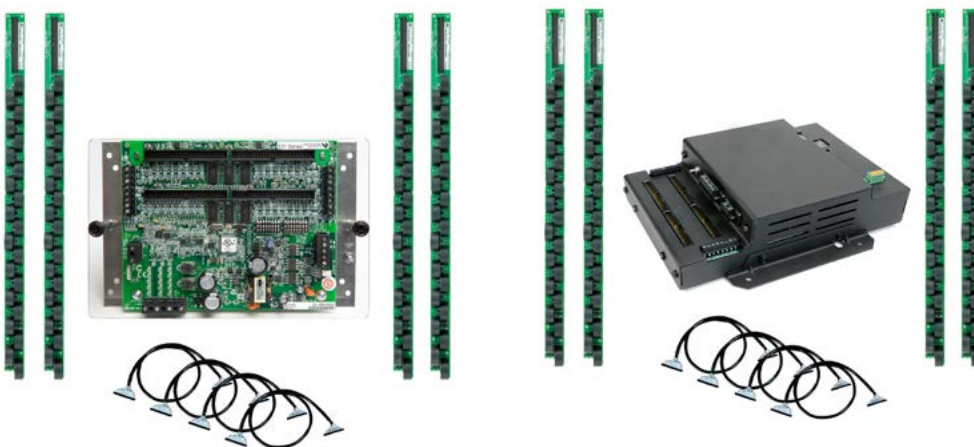

> Multi-circuit metering

PowerLogic BCPM

The PowerLogic BCPM is a highly accurate, full-featured metering product designed for the unique, multi-circuit and minimal space requirements of a high performance power distribution unit (PDU) or remote power panel (RPP).

It offers class 1 (1 %) power and energy system accuracy (including 50 A or 100 A CTs) on all branch channels. The BCPM monitors up to 84 branch circuits and the incoming power mains to provide information on a complete PDU. Full alarming capabilities ensure that potential issues are dealt with before they become problems.

Applications

- Maximise uptime and avoid outages
- Optimise existing infrastructure
- Improve power distribution efficiency
- Track usage and allocate energy costs
- Enable accurate sub-metering

PB 113065



[> Multi-circuit metering](#)

The solution for

Markets that can benefit from a solution that includes PowerLogic BCPM series meters:

- Data centres
 - Buildings
-

Benefits

The flexible BCPM fits any PDU or RPP design and supports both new and retrofit installations. It has exceptional dynamic range and accuracy, and optional feature sets to meet the energy challenges of mission critical data centres.

Competitive advantages

- Fit any PDU or RPP design for both new and retrofit projects
- Class 1.0 system accuracy
- Ethernet communication

Power management solutions

Schneider Electric provides innovative power management solutions to increase your energy efficiency and cost savings, maximise electrical network reliability and availability, and optimise electrical asset performance.

Conformity of standards

- ANSI C12.1
- IEC 61010-1
- IEC 62053-21 Class 1
- UL508

BCPM

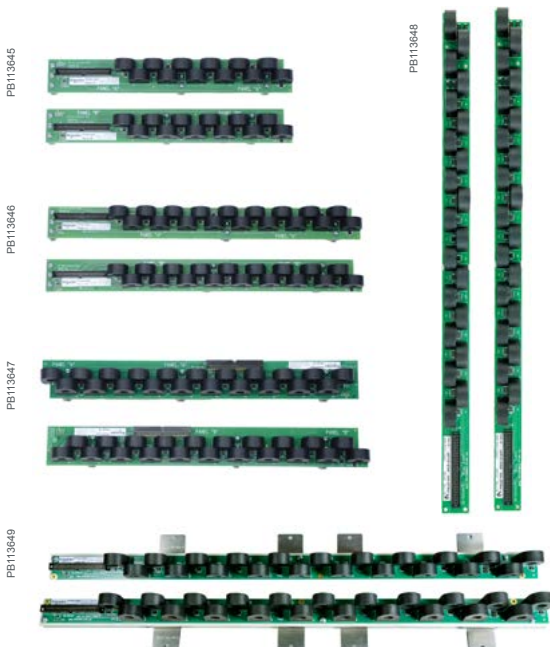
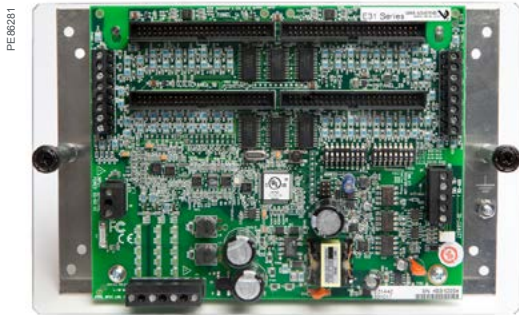

Main characteristics

- Monitor up to 84 branch circuits with a single BCPM.
- Ideal for installation in both new PDUs and retrofit projects
- New installations:
 - BCPM with solid core CTs monitors up to 84 branch circuits using 2 or 4 CT strips. Solid core CTs are rated to 100 A CTs and are mounted on strips to simplify installation. CT strips are available with 12, 18 or 21 CTs per strip on 18 mm spacings. 21 CT strips with 3/4in or 1in spacings are also available.
- Retrofit projects:
 - BCPMSC with split-core CTs is ideal for retrofits. Any number of split-core CTs, up to 84 maximum, can be installed with a single BCPM. Three sizes of CT are supported (50 A, 100 A, and 200 A) and all three CT sizes can be used on a single BCPM. Adapter boards with terminals for split-core CTs can be mounted using DIN-rail, Snaptrack or on a common mounting plate with the main board (42 ch Y63 models only).
- IEC Class 1 metering accuracy
 - Accurately monitor very low current levels, down to a quarter-Amp.
 - Easily differentiate between the flow of low current and a trip where no current flows.
- Class 1.0 system accuracy for Revenue Grade measurements
 - Branch Power and Energy measurements fully meet ANSI and IEC class 1 accuracy requirements with 50 or 100 A CTs included. No need to de-rate meter branch accuracy to allow for CTs. Voltage and current measurement accuracy is 0.5 % and currents are measured down to 50mA. Easily differentiate between the flow of low current and a trip where no current flows.
 - Class 1.0 system accuracy for Revenue Grade measurements
 - Branch Power and Energy measurements fully meet ANSI and IEC class 1 accuracy require
- Power quality: obtain basic power quality data thanks to the measurement of Total Harmonic Distortion percentages on voltages and current. (V L-L, V L-N, I L-N).
- Designed to fit any PDU or RPP design
 - Lowers your total installation costs as well as the cost per meter point by supporting both new and retrofit installations.
- Communicates with your various systems: BCPMA, and BCPMSCA have a Modbus RTU connection BCPME, and BCPMSCE, have a serial connection for either Modbus RTU or BACnet MS/TP. And there is an ethernet connection for Modbus TCP, BACnet IP and SNMP at the same time. Allowing the concurrent use of an Energy Management System, a Building Management System and an IT system.
- Compatible with PowerLogic power monitoring software
 - Easily turn the large amount of data collected by the devices into useful decision-making information.
- Flexible Configuration capability
 - Set the ordering and orientation of CT strips, assign individual CT size and phases, support for 1, 2, and 3-pole breakers in any configuration.

BCPM

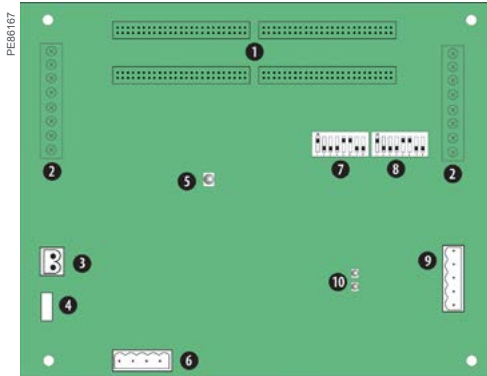

- PowerLogic BCPM
- 1 50-pin ribbon cable connectors (data acquisition board).
 - 2 Auxiliary inputs.
 - 3 Control (mains) power connection.
 - 4 Control power fuse.
 - 5 Alive LED.
 - 6 Voltage taps.
 - 7 Communications address DIP switches.
 - 8 Communications settings DIP switch.
 - 9 RS-485 2 connection.
 - 10 RS-485 LEDs.

Feature selection		BCPMA	BCPME
General			
Use on LV systems		b	b
Power and energy measurements			
Mains		b	b
Branch circuits		b	b
Instantaneous rms values			
Voltage, frequency		b	b
Current		b	b
Active power	Total and per phase	b	b
Power factor	Total and per phase	b	b
Energy values			
Active energy		b	b
Demand values			
Total active power	Present and max. values	b	b
Power quality measurements			
THD % (V L-L, V L-N, I L-N)		b	b
Detection of over-voltage/under-voltage		b	b
Sampling rate points per cycle		2560 Hz	2560 Hz
Alarming			
Alarms		b	b
Power supply			
AC version		90-277 V AC	100-277 V AC
Communication			
RS-485 port		b	b
Modbus RTU		RTU	b
Modbus TCP		1g	b
BACnet IP		1g	b
BACnet MS/TP		1g	b
SNMP protocol		1g	b
Ethernet Port		1g	b

g1 Add E8951 Gateway

BCPM

PE89168

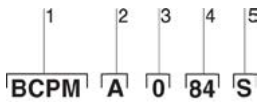

Example BCPM with solid core CTs part number

1. Model
2. Feature set
3. CT spacing (solid core models only)
4. Number of circuits
5. Brand

The PowerLogic BCPM uses .333 V AC output split-core CTs for the auxiliary inputs. These CTs are ordered separately from the BCPM.

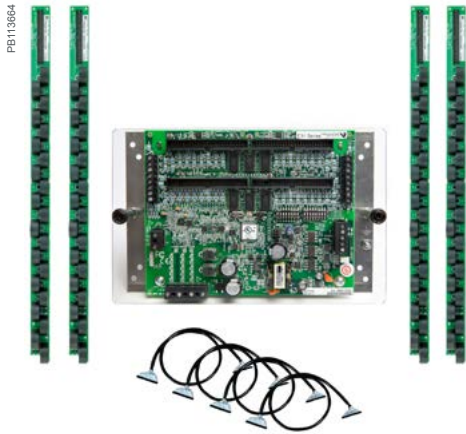

BCPM part numbers

BCPM with solid core CTs			
Item	Code	Description	
1	Model	BCPM	BCPM with solid core CTs. Highly accurate meter that monitors branch circuits and the incoming power mains and includes full alarming capabilities
2	Feature set	A	Advanced - Monitors power & energy per circuit & mains, Modbus RTU only (add E8951 for other protocols), Meter Main Board comes on an aluminum mounting plate
		E	Advanced, with Ethernet - Monitors power & energy per circuit & mains, Meter Main Board is partially enclosed in a metal housing
3	CT spacing	0	3/4in (19 mm) CT spacing
		1	1in (26 mm) CT spacing
		2	18 mm CT spacing
4	Number of circuits	24	24 circuits, (2) 12-CT strips (18 mm spacing only)
		36	36 circuits, (2) 18-CT strips (18 mm spacing only)
		42	42 circuits, (2) 21-CT strips
		48	48 circuits, (4) 12-CT strips (18 mm spacing only)
		72	72 circuits, (4) 18-CT strips (18 mm spacing only)
		84	84 circuits, (4) 21-CT strips
5	Brand	S	Schneider Electric

* Quantity and style of CT strips and cables included varies by model

BCPM

PB113725

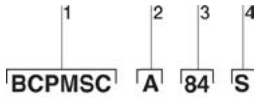

Example BCPMSC with split-core CTs part number.

- 1 Model.
- 2 Feature set.
- 3 Number of circuits.
- 4 Brand.

PB113666



PB113730



BCPM part numbers (contd.)

		BCPM with split-core CTs	BCPM with split-core CTs
1	Model	BCPMSC	BCPM with split-core CTs. Highly accurate meter that monitors branch circuits and the incoming power mains and includes full alarming capabilities
2	Feature set	A	Advanced - Monitors power and energy per circuit and mains, Modbus RTU only (add E8951 for other protocols), Meter Main Board comes on an aluminum mounting plate
		B	Intermediate - Monitors current per circuit, power and energy per mains, Modbus RTU only (add E8951 for other protocols), Meter Main Board comes on an aluminum mounting plate
		C	Basic - Monitors current only per circuit and mains, Modbus RTU only (add E8951 for other protocols), Meter Main Board comes on an aluminum mounting plate
		E	Advanced, with Ethernet - Monitors power & energy per circuit & mains, Modbus RTU only (add E8951 for other protocols), Meter Main Board is enclosed in a metal housing
3	Number of circuits	1	42 circuit main and adapter boards (no branch CTs or ribbon cables, order separately)
		2	84 circuit main and adapter boards (no branch CTs or ribbon cables, order separately)
		30	30 split-core CTs (50 A)
		42	42 split-core CTs (50 A)
		60	60 split-core CTs (50 A)
		84	84 split-core CTs (50 A)
4	Brand	Y63	42 circuits – main and adapter boards on single mounting plate (no branch CTs or ribbon, order separately) - Feature set A only
		S	Schneider Electric

*The BCPMSC models with 1, 2 or Y63 as the number of circuits DO NOT INCLUDE ANY branch CTs or ribbon cables (they include only the Main board and adapter board assemblies). These models are provided to allow users to order a specific combination of CT quantities, CT sizes, CT lead lengths and ribbon cable styles and lengths. The CTs and cables must be ordered separately.

The PowerLogic BCPMSC uses .333 V AC output split-core CTs for the auxiliary inputs. These CTs are ordered separately from the BCPMSC.

BCPM



Flat ribbon cable



Round ribbon cable

Cabling and connection

Flat ribbon cables are recommended for use when the BCPM printed circuit board will be mounted inside of the PDU that is being monitored. Round ribbon cables are the preferred choice when the ribbon cable will be threaded through conduit.

BCPM part numbers for solid and split-core CTs (contd.)

BCPM with split-core CTs	
Commercial ref. no.	Description
BCPMA042S	42-circuit solid core power & energy meter, 100 A CTs (2 strips), 19 mm spacing
BCPMA084S	84-circuit solid core power & energy meter, 100 A CTs (4 strips), 19 mm spacing
BCPMA142S	42-circuit solid core power & energy meter, 100 A CTs (2 strips), 25 mm spacing
BCPMA184S	84-circuit solid core power & energy meter, 100 A CTs (4 strips), 25 mm spacing
BCPMA224S	24-circuit solid core power & energy meter, 100 A CTs (2 strips), 18 mm spacing
BCPMA236S	36-circuit solid core power & energy meter, 100 A CTs (2 strips), 18 mm spacing
BCPMA242S	42-circuit solid core power & energy meter, 100 A CTs (2 strips), 18 mm spacing
BCPMA248S	48-circuit solid core power & energy meter, 100 A CTs (4 strips), 18 mm spacing
BCPMA272S	72-circuit solid core power & energy meter, 100 A CTs (4 strips), 18 mm spacing
BCPMA284S	84-circuit solid core power & energy meter, 100 A CTs (4 strips), 18 mm spacing
BCPME042S	42-circuit solid core power & energy meter w/Ethernet, 100 A CTs (2 strips), 19 mm spacing
BCPME084S	84-circuit solid core power & energy meter w/Ethernet, 100 A CTs (4 strips), 19 mm spacing
BCPME142S	42-circuit solid core power & energy meter w/Ethernet, 100 A CTs (2 strips), 25 mm spacing
BCPME184S	84-circuit solid core power & energy meter w/Ethernet, 100 A CTs (4 strips), 25 mm spacing
BCPME224S	24-circuit solid core power & energy meter w/Ethernet, 100 A CTs (2 strips), 18 mm spacing
BCPME236S	36-circuit solid core power & energy meter w/Ethernet, 100 A CTs (2 strips), 18 mm spacing
BCPME242S	42-circuit solid core power & energy meter w/Ethernet, 100 A CTs (2 strips), 18 mm spacing
BCPME248S	48-circuit solid core power & energy meter w/Ethernet, 100 A CTs (4 strips), 18 mm spacing
BCPME272S	72-circuit solid core power & energy meter w/Ethernet, 100 A CTs (4 strips), 18 mm spacing
BCPME284S	84-circuit solid core power & energy meter w/Ethernet, 100 A CTs (4 strips), 18 mm spacing

BCPM

PB113651



BCPMSCxY63S 42-circuit split-core models come with the main board, (2) adapter boards and ribbon cables all mounted on a backplate, to simplify installation.

PE86183



PowerLogic™ LVCT0xxxxS Split-core Low-voltage (1/3V) CTs for Aux inputs (Mains) are ideal for retrofit applications

PB113652

PB113657

PB113658



PowerLogic™ LVCT2xxxxS Low-voltage (1/3V) solid core CTs for Aux inputs (Mains) are ideal for panel builders (small, medium, large)

BCPM part numbers for solid and split-core CTs (contd.)

BCPM with split-core CTs

Commercial ref. no.	Description
BCPMSCA1S	42-circuit split-core power and energy meter, CTs and cables sold separately
BCPMSCA2S	84-circuit split-core power and energy meter, CTs and cables sold separately
BCPMSCA30S	30-circuit split-core power and energy meter, (30) 50 A CTs & (2) 1.2 m cables
BCPMSCA42S	42-circuit split-core power and energy meter, (42) 50 A CTs & (2) 1.2 m cables
BCPMSCA60S	60-circuit split-core power and energy meter, (60) 50 A CTs & (4) 1.2 m cables
BCPMSCAY63S	42-circuit split-core power and energy meter, all boards on backplate, CTs and cables sold separately
BCPMSCA84S	84-circuit split-core power and energy meter, with (84) 50 A CTs & (4) 1.2 m cables
BCPMSCY1S	42-circuit split-core power and energy meter w/Ethernet, CTs and cables sold separately
BCPMSCY2S	84-circuit split-core power and energy meter w/Ethernet, CTs and cables sold separately
BCPMSCY30S	30-circuit split-core power and energy meter w/Ethernet, (30) 50 A CTs & (2) 1.2 m cables
BCPMSCY42S	42-circuit split-core power and energy meter w/Ethernet, (42) 50 A CTs & (2) 1.2 m cables
BCPMSCY60S	60-circuit split-core power and energy meter w/Ethernet, (60) 50 A CTs & (4) 1.2 m cables
BCPMSCY84S	84-circuit split-core power and energy meter w/Ethernet, (84) 50 A CTs & (4) 1.2 m cables

The PowerLogic™ BCPM uses .333 V AC output split-core CTs for the auxiliary inputs. These CTs are ordered separately from the BCPM.

BCPM

Commercial ref. no.		
BCPM split-core branch CTs and adapter boards		
BCPMSCADPBS	BCPM adapter boards, quantity 2, for split-core BCPM	
BCPMSCCT0	BCPM 50 A split-core CTs, Quantity 6, 1.8 m lead lengths	
BCPMSCCT0R20	BCPM 50 A split-core CTs, quantity 6, 6 m lead lengths	
BCPMSCCT1	BCPM 100 A split-core CTs, Quantity 6, 1.8 m lead lengths	
BCPMSCCT1R20	BCPM 100 A split-core CTs, Quantity 6, 6 m lead lengths	
BCPMSCCT3	BCPM 200 A split-core CTs, Quantity 1, 1.8 m lead lengths	
BCPMSCCT3R20	BCPM 200 A split-core CTs, Quantity 1, 6 m lead lengths	
Commercial ref. no.		
Additional accessories for use with BCPM products		
BCPMCOVERS	BCPM circuit board cover	
BCPMREPAIR	CT repair kit for solid core BCPM (includes one CT)	
H6803R-0100	Additional 100 A split-core CT for use with solid core repair kit	
E8951	Modbus to BACnet protocol converter	
CBL016	Flat Ribbon cable (quantity 1) for BCPM, length = 1.2 m	
CBL017	Flat Ribbon cable (quantity 1) for BCPM, length = 1.5 m	
CBL018	Flat Ribbon cable (quantity 1) for BCPM, length = 1.8 m	
CBL020	Flat Ribbon cable (quantity 1) for BCPM, length = 3.0 m	
CBL021	Flat Ribbon cable (quantity 1) for BCPM, length = 6.1 m	
CBL022	Round Ribbon cable (quantity 1) for BCPM, length = 1.2 m	
CBL024	Round Ribbon cable (quantity 1) for BCPM, length = 6.1 m	
1/3 V low-voltage Split-core CTs for Aux inputs (Mains)		
Commercial ref. no.	Amperage rating	Inside dimensions
LVCT00050S	50 A	10 mm x 11 mm
LVCT00101S	100 A	16 mm x 20 mm
LVCT00202S	200 A	32 mm x 32 mm
LVCT00102S	100 A	30 mm x 31 mm
LVCT00202S	200 A	30 mm x 31 mm
LVCT00302S	300 A	30 mm x 31 mm
LVCT00403S	400 A	62 mm x 73 mm
LVCT00603S	600 A	62 mm x 73 mm
LVCT00803S	800 A	62 mm x 73 mm
LVCT00804S	800 A	62 mm x 139 mm
LVCT01004S	1000 A	62 mm x 139 mm
LVCT01204S	1200 A	62 mm x 139 mm
LVCT01604S	1600 A	62 mm x 139 mm
LVCT02004S	2000 A	62 mm x 139 mm
LVCT02404S	2400 A	62 mm x 139 mm
1/3 V low-voltage Solid core CTs for Aux inputs (Mains)		
Commercial ref. no.	Amperage rating	Inside dimensions
LVCT20050S	50 A	10 mm
LVCT20100S	100 A	10 mm
LVCT20202S	200 A	25 mm
LVCT20403S	400 A	31 mm

BCPM

Technical specifications

Electrical characteristics

Type of measurement

Accuracy	Power/energy	1 % system accuracy (including 50A or 100A branch CTs)
	Voltage	±0.5 % of reading
	Current	±0.5 % of reading
Minimum "ON" current		50mA
Sampling rate Points per cycle		2560 Hz
Data update rate		1.8 seconds (Modbus), 14 seconds (BACnet) 20 sec (SNMP)
Input-voltage characteristics	Measured voltage	150 – 480 V AC L-L ⁽¹⁾ 90 – 277 V AC L-N ⁽¹⁾
	Measurement range	150 – 480 V AC L-L ⁽¹⁾ 90 – 277 V AC L-N ⁽¹⁾
Power supply	AC	100 – 277 V AC (50/60 Hz)
Auxiliary CT Current Input Range		0-0.333V; CTs must be rated for use with Class 1 voltage inputs

Mechanical characteristics

Weight		1.5 kg
Dimensions	A/B/C model Circuit board	288 x 146 mm
E model housing (w/brackets on long sides)		253 mm W x 307 mm H x 71 mm D
E model housing (w/brackets on short ends)		210 mm W x 353 mm H x 71 mm D

Environmental conditions

Operating temperature	0 to 60 °C
Storage temperature	-40 °C to 70 °C
Installation category	CAT III, pollution degree 2

Safety

Europe	IEC 61010
U.S. and Canada	UL 508 Open type device

Communication

RS-485 (A/B/C models)	Baud rate: DIP-switch selectable 9600, 19200, 38400 DIP-switch selectable 2-wire or 4-wire RS-485. Parity selectable: Even, Odd or None.
RS-485 (A models)	Baud rate: configured via Web-server. Baud selectable: 9600, 19200, 38400. Parity selectable: Even, Odd or None. 2-wire RS-485.
Ethernet (E models)	10/100 Mbit Ethernet. RJ-45 connection. Static IP or DHCP.
Protocols	Modbus RTU on all models, BCPME models also support Modbus TCP, SNMP, BACnet IP & BACnet MS/TP

Firmware characteristics

Detection of over-voltage/under-voltage	User-defined alarm thresholds for over-voltage and under-voltage detection
Alarms	Four alarm levels: high-high, high, low and low-low (users define the setpoints for each). Each alarm has a latching status to alert the operator that an alarm has previously occurred. High and Low alarms have instantaneous status to let the operator know if the alarm state is still occurring.
Firmware update	Update via Modbus

BCPM

1/3 V low-voltage CT (LVCT) for Mains - Technical specifications

Electrical characteristics	
Accuracy	1 % from 10 % to 100 % of rated current(LVCT0xxxx0S/1S/2S/3S/4S [split-core]) 0.5 % from 5 % to 100 % of rated current (LVCT2xxxx0S/2S/3S [solid core])
Frequency range	50/60 Hz
Leads	18 AWG, 600 V AC, 1.8m standard length
Max. voltage L-N sensed conductor	300 V AC (LVCT0xxxx0S) 600 V AC (LVCT0xxxx1S/2S/3S/4S, LVCT2xxxxS)
Environmental conditions	
Operating temperature	0 °C to 70 °C (LVCT0xxxx0S/1S) -15 °C to 60 °C (LVCT0xxxx2S/3S/4S less than 2400A) -15 °C to 60 °C (LVCT02404S [2400A]) -40 °C to 85 °C (LVCT2xxxx0S/2S/3S [solid core])
Storage temperature	-40 °C to 105 °C (LVCT0xxxx0S/1S) -40 °C to 70 °C (LVCT0xxxx2S/3S/4S) -50 °C to 105 °C (LVCT2xxxx0S/2S/3S [solid core])
Humidity range	0 to 95 % non-condensing

BCPM

PowerLogic BCPM dimensions

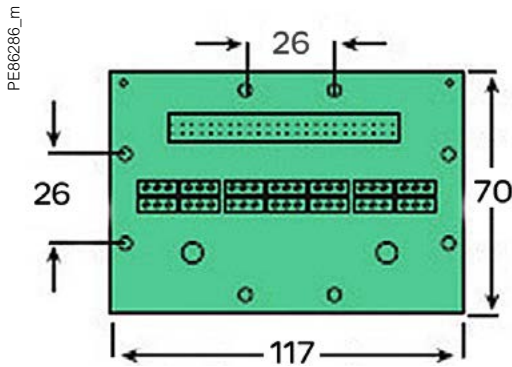

PowerLogic BCPM adapter board (one board per 21 split-core branch CTs)

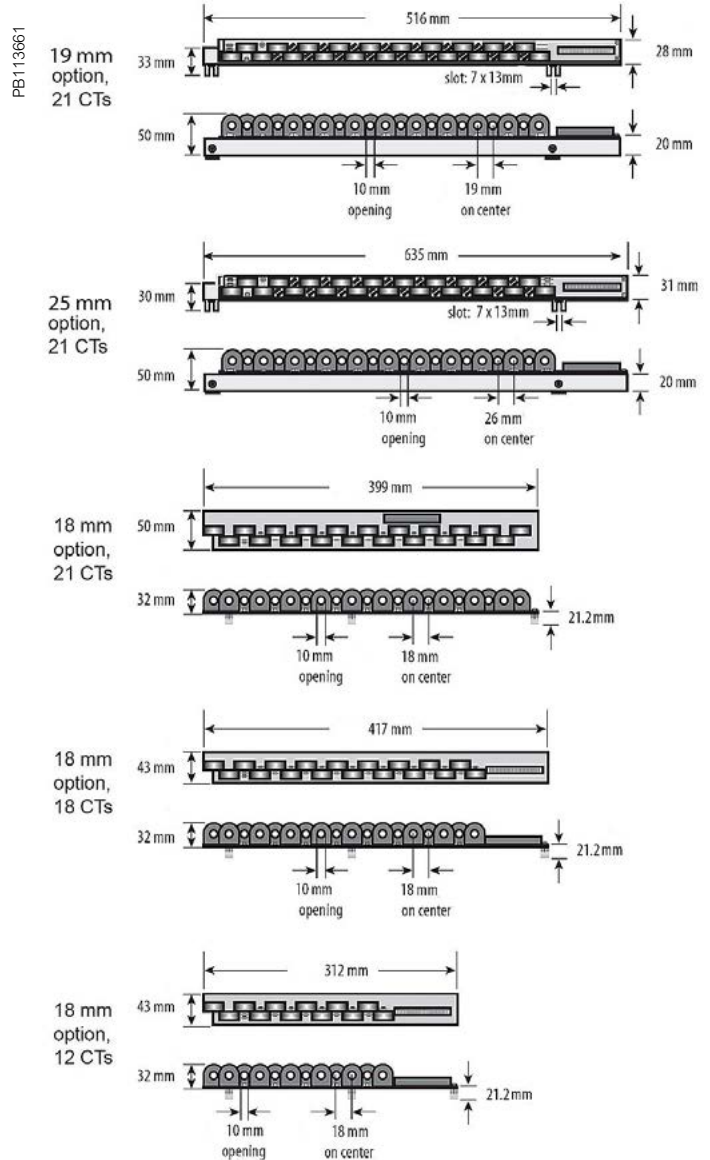
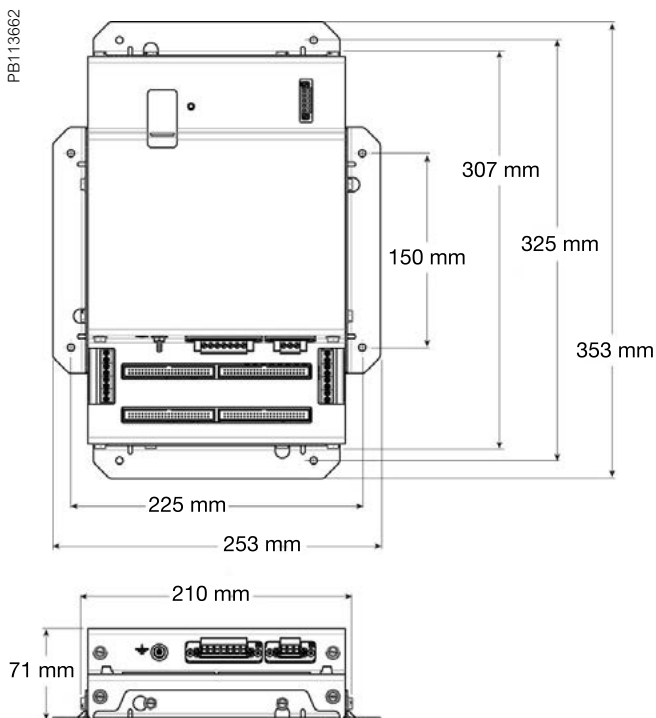
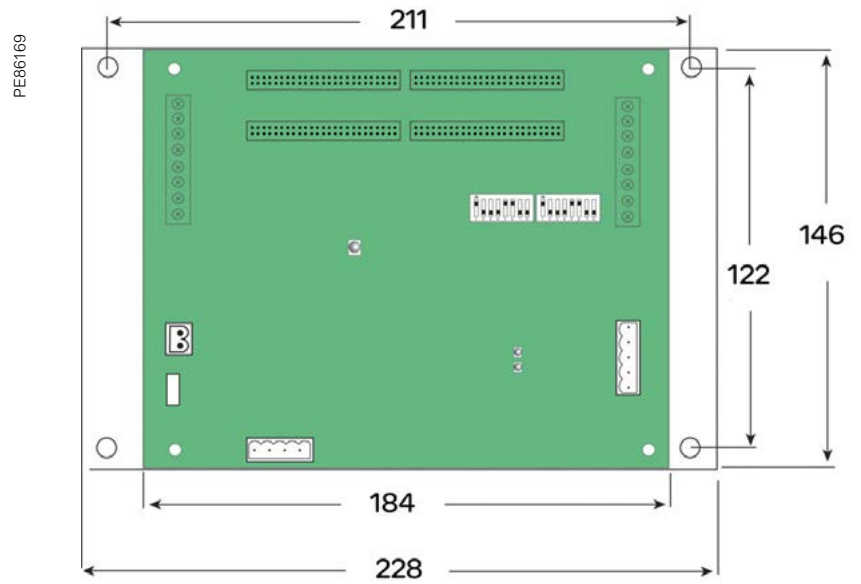

BCPM

50 A-200 A Split-core CT dimensions

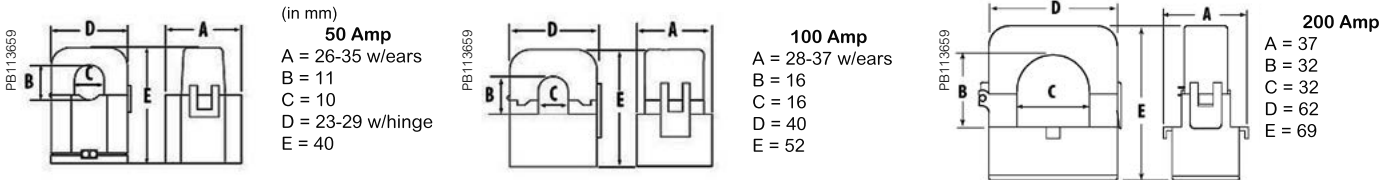

These dimensions apply to both BCPMSCCTxx (branch CTs) and LVCT0xxx0S/1S (for Mains) 50 A-200 A CT families.

Solid core CT dimensions

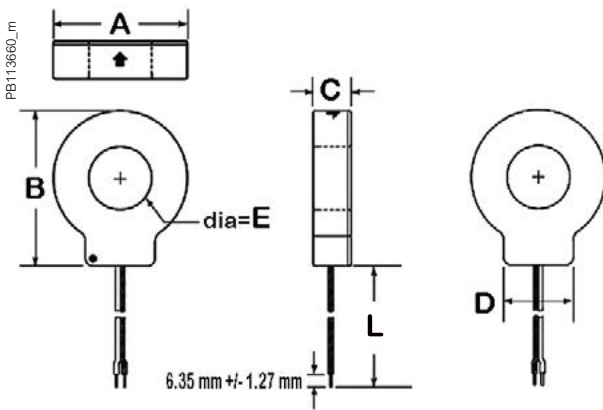

Model	L	A	B	C	D	E
LVCT20050S	1.8 m	33 mm	38 mm	18 mm	21 mm	10 mm
LVCT20100S	1.8 m	59 mm	66 mm	18 mm	31 mm	25 mm
LVCT20202S	1.8 m	70 mm	82 mm	25 mm	36 mm	31 mm

1/3 V low-voltage CT form factor

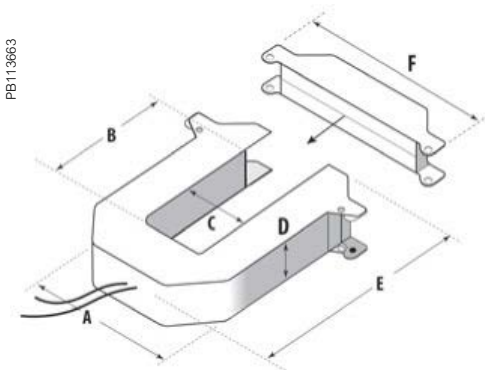

Small form factor
100/200/300 Amp
 A = 96 mm
 B = 30 mm
 C = 31 mm
 D = 30 mm
 E = 100 mm
 F = 121 mm

Medium form factor
400/600/800 Amp
 A = 125 mm
 B = 73 mm
 C = 62 mm
 D = 30 mm
 E = 132 mm
 F = 151 mm

Large form factor
800/1000/1200/1600/2000/2400 Amp
 A = 125 mm
 B = 139 mm
 C = 62 mm
 D = 30 mm
 E = 201 mm
 F = 151 mm

BCPM

PowerLogic BCPM with solid core CT strips installation details

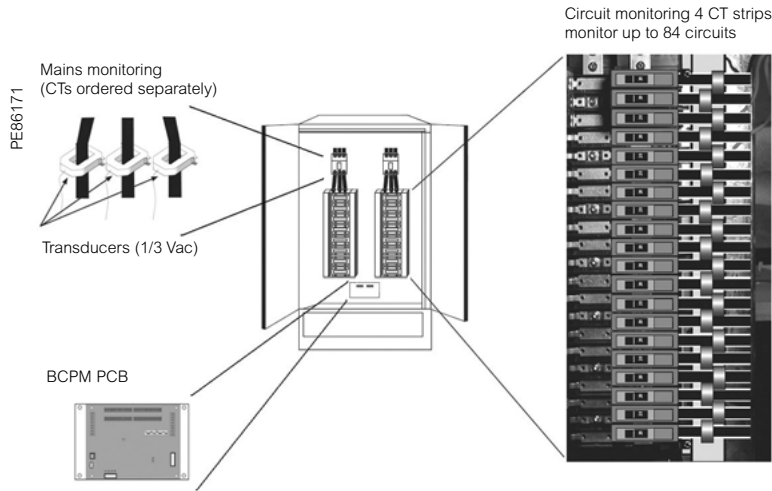

PowerLogic BCPM with split-core CTs installation details

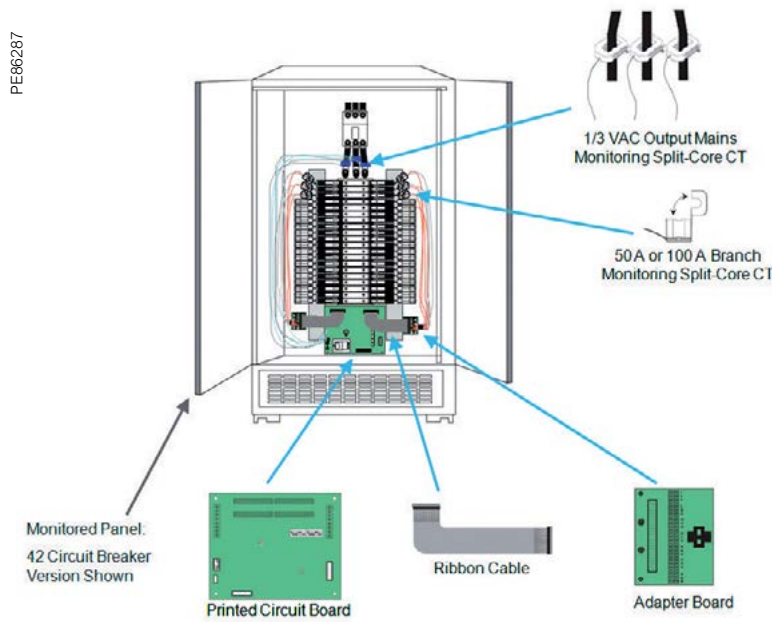

Communications & Gateways



Overview

This is a part of your metering solution which provides an interface between energy monitoring software and your metering points via GPRS, wired connection and Wi-Fi. We also offer the option of an integrated gateway-server which provides an all-in-one energy management solution. They are fully capable of supporting EcoStruxure™ Power Management software.



Communications & Gateways

Data loggers, gateways and remote terminal units help measured data reach the power monitoring software for analyses.

They are fundamental components in most power and energy management system architectures.

- Link150 Ethernet gateway
- Data logger Com'X 210
- Data logger Com'X 510
- ION7550 RTU

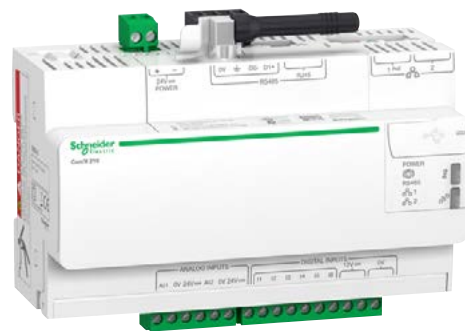

> [Communications & Gateways](#)

Serial link

With Schneider Electric's advanced communication technology, all forms of power monitoring data can be accessed remotely, quickly and easily.

In all architectures, the communication interface serves as the link between the installation devices and the PC running the operating software. It provides the physical link and protocol adaptation. Adaptation is required because the communication systems used by the PC (Modbus via RS-232 and/or Ethernet) are generally not those used by the installation devices (e.g. the Modbus protocol via RS-485).

Dedicated application software prepares the information for analysis under the best possible conditions.

In addition, an Modbus-Ethernet gateway in serial port slave mode allows a serial Modbus master device to access information from other devices across a Modbus TCP/IP network.

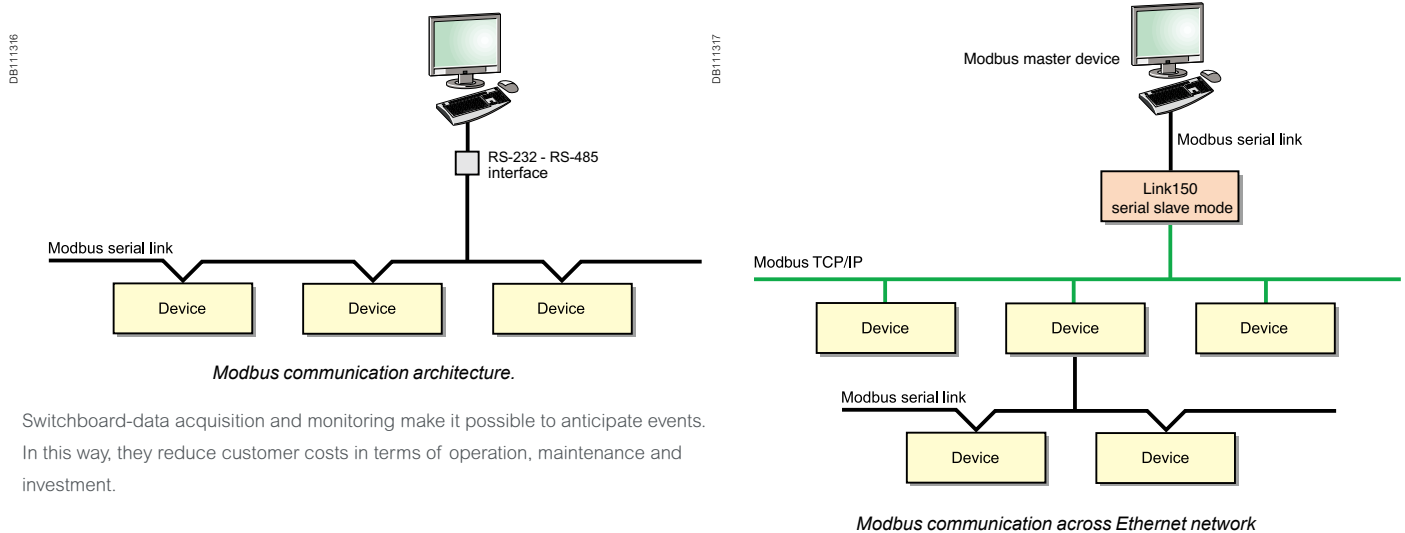

Switchboard-data acquisition and monitoring make it possible to anticipate events. In this way, they reduce customer costs in terms of operation, maintenance and investment.

Ethernet link

Using modern web technologies, the operator can access information from monitoring and protection devices using any PC connected to the network, with all the required security.

The Ethernet Modbus-Ethernet gateway* or the integrated gateway-servers* provide connectivity between Modbus RS-485 and Ethernet Modbus TCP/IP.

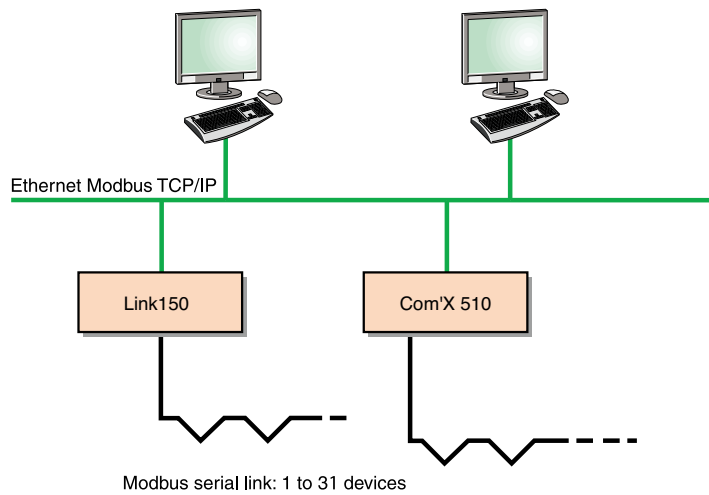

Ethernet communication architecture.

The services available with these technologies considerably simplify the creation, maintenance and operation of these supervision systems.

The application software is now standardised: the web interface into the system does not require custom web pages to be created. It is personalised by simply identifying the components in your installation and can be used as easily as any internet application.

The first step in this approach is the integrated gateway-server with HTTP pages. Power management software (EcoStruxure™ Power Monitoring Expert and EcoStruxure™ Power SCADA Operation), running on a PC, provide broader coverage for more specific need

Link150 Ethernet gateway

The Link150 gateway provides fast, reliable Ethernet connectivity in the most demanding applications, from a single building to a multi-site enterprise. This gateway supports meters, monitors, protective relays, trip units, motor controls and other devices that need to communicate data quickly and efficiently. It is your simple, cost-effective serial line to full Ethernet connectivity.

Applications

- Energy management
- Power distribution
- Building automation
- Factory automation

PB115427



> [Link150 Ethernet gateway](#)

The solution for

All markets that can benefit from a solution that includes the Link150 gateway:

- Buildings
- Data centre
- Healthcare
- Industry
- Infrastructure
- Utility

Benefits

- Easy to install and setup
- Easy to maintain
- Advanced security feature
- Compatible with Schneider Electric software offerings
- Reliable Modbus to Ethernet protocol conversion

Energy and power management software

Powerlogic software is recommended as a user interface which provides access to all status and measurement information. It also prepares summary reports for energy and power management. The Link150 is compatible with

- EcoStruxure™ Power Monitoring Expert software
- EcoStruxure™ Power SCADA Operation

Conformity of standards

- EN 55022/EN 55011/ FCC Class A
- EN 61000-4-4
- EN 61000-4-5
- EN 61000-6-2
- EN 61000-4-6
- EN 61000-4-2
- EN 61000-4-8
- EN 61000-4-3
- EN 60950

Architecture

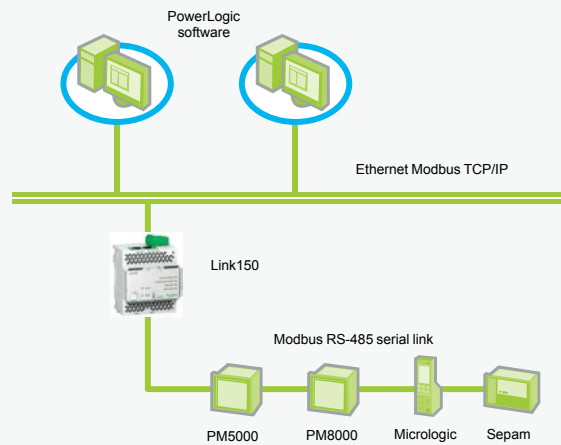

Security

- Secure user interface including user's name and password for login
- Advanced security features to allow users to specify which Modbus TCP/IP master devices may access attached serial slave devices
- Modbus TCP/IP filtering feature
- Allows user to specify the level of access for each master device as Read-only or Full access
- Web pages provide easy configuration and setup

Commercial ref. no.	Product description
EGX150	Link150 Ethernet Gateway

Link150 Ethernet gateway

Technical specifications	
	Link150
Weight	175 g without packing
Dimensions (HxWxD)	72 x 105 x 71 mm
Mounting	DIN rail
Power-over-Ethernet (PoE)	Class 3
Power supply	24 V DC (-20/+10 %) or Power over Ethernet (PoE Class 3 IEEE 802.3 af) at 15 W
Consumption (typical)	24 V DC, 130 mA at 20 °C PoE 48 V DC, 65 mA at 20 °C
Ambient operating temperature	-25 to 70 °C
Ambient storage temperature	-40 to 85 °C
Humidity rating	5 % to 95 % relative humidity (without condensation) at +55°C
Pollution Degree	Level 2
IP Ratings	On the front panel (wall-mounted enclosure): IP4x Connectors: IP20 Other parts: IP30
Regulatory/standards compliance for electromagnetic interference	
Emissions (radiated and conducted)	EN 55022/EN 55011/FCC class A
Immunity for industrial environments:	
electrostatic discharge	EN 61000-6-2
radiated RF	EN 61000-4-2
electrical fast transients	EN 61000-4-3
surge	EN 61000-4-4
conducted RF	EN 61000-4-5
power frequency	EN 61000-4-6
magnetic field	EN 61000-4-8
Regulatory/standards compliance for safety	
Safety - IEC	IEC 60950
Safety - ULg	UL 60950 UL 61010-2-201
EMC	IEC 6100-6-2
Australia	C-tick - RCM
Sustainability	Green Premium
Serial ports	
Number of ports	2 (1 available at a time)
Types of ports	RS-232 or RS-485 (2-wire or 4-wire), depending on settings
Protocol	Modbus, Serial
Baud rates	19200 bps (factory setting), 2400 bps, 4800 bps, 9600 bps, 38400 bps, 56000 bps ^{gg} , 57600 bps ^{gg}
Maximum number of connected devices	32 (directly) 247 (indirectly)
Ethernet ports (used as a switch)	
Number of ports	2
Type of port	10/100BASE-TX (802.3af) por
Protocol	HTTP, Modbus TCP/IP, FTP, SNMP (MIB II)

^g Dual listed for US and Canada

^{gg} Only available when Physical Interface is set to RS-232 and Transmission Mode is set to Modbus ASCII

Link150 Ethernet gateway

Parts

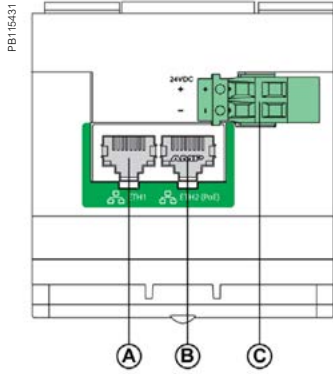

- A** Ethernet 1 communication port
- B** Ethernet 2 (PoE) communication port
- C** Midspan PoE injector

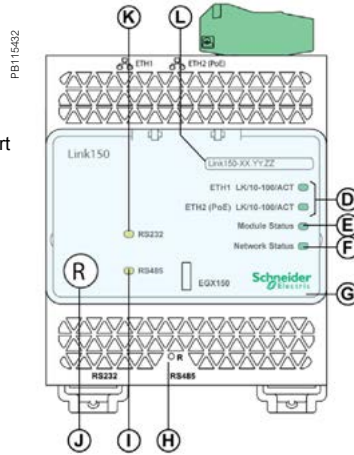

- D** Ethernet communication LEDs
- E** Module status LED
- F** Network status LED
- G** Removable transparent cover
- H** Reset pin
- I** RS-485 traffic status LED
- J** Device soft restart button (Accessible through closed cover)
- K** RS-232 traffic status LED
- L** Device name label

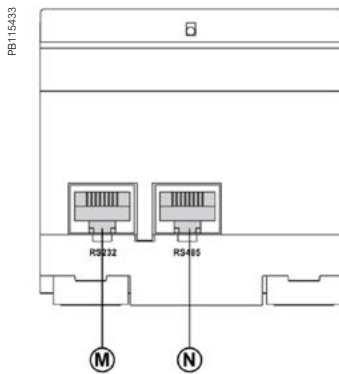

- M** RS-232 port
- N** RS-485 port

Dimensions

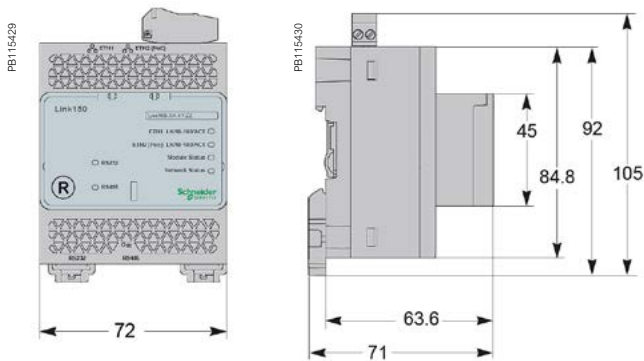

DIN rail mounting

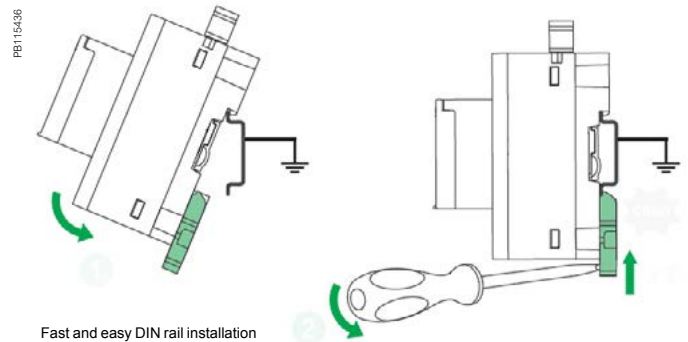

See appropriate Installation Guide for this product.

Com'X 210

A highly flexible plug-and-play Energy Server Com'X 210 collects and stores WAGES consumptions and environmental parameters such as temperatures, humidity and CO₂ levels in a building. Data is periodically transmitted as a report to an internet database server for further processing. The Energy Server Com'X 210 not only reduces your technical complexity, but helps to manage your energy.

Applications

The quickest path to multi-site energy management and on-line services

- Delivers batches of data ready to process by EcoStruxure™ Power Management solutions and services
- Publishes logged data to the Schneider Electric cloud or another hosted platform

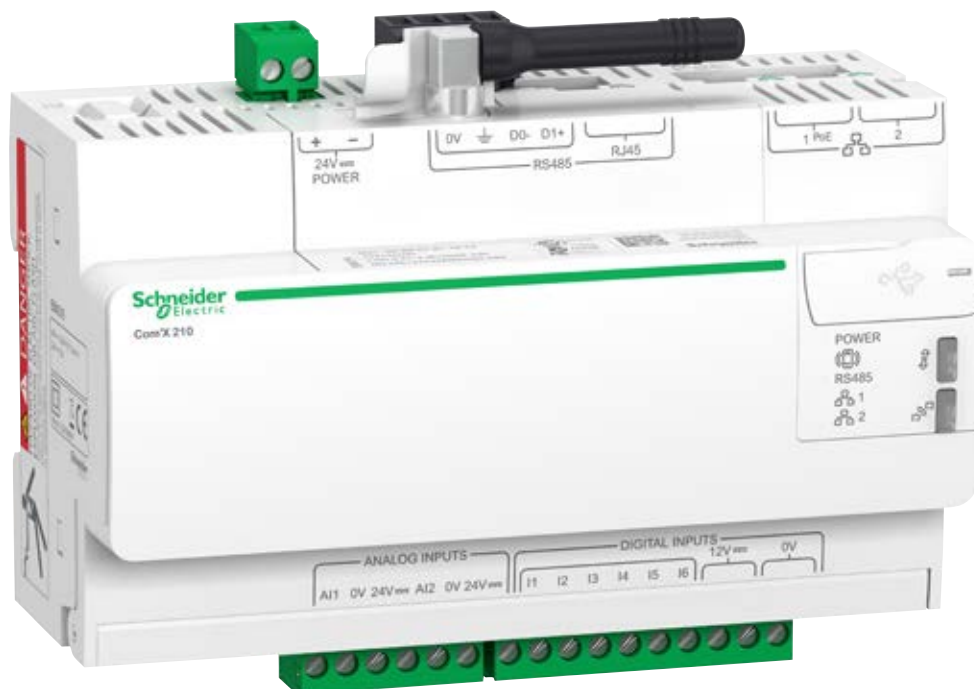

> Com'X 210

The solution for

All markets that can benefit from a solution that includes data logger Com'X 210:

- Buildings
- Industry

Benefits

- Data collection from up to 64 field devices
- Data publishing leveraging existing infrastructures, Ethernet or Wi-Fi, GPRS-ready
- Quick fitting into electrical switchboards thanks to DIN rail clipping and profile
- Quick setup and configuration thanks to intuitive HMI

Energy management solutions

The data collected and stored by Com'X 210 can be processed and displayed as webpages through web services provided by Schneider Electric, such as EcoStruxure™ Power Management software products, or by any private energy platform.

The Com'X 210 also provides a transparent interface between Ethernet-based networks and field devices. This gateway function supports the use of monitoring software, such as EcoStruxure™ Power Monitoring Expert (PME) for data collection, trending, event management, analysis and further processing.

Conformity of standards

- EN 60950

Architecture

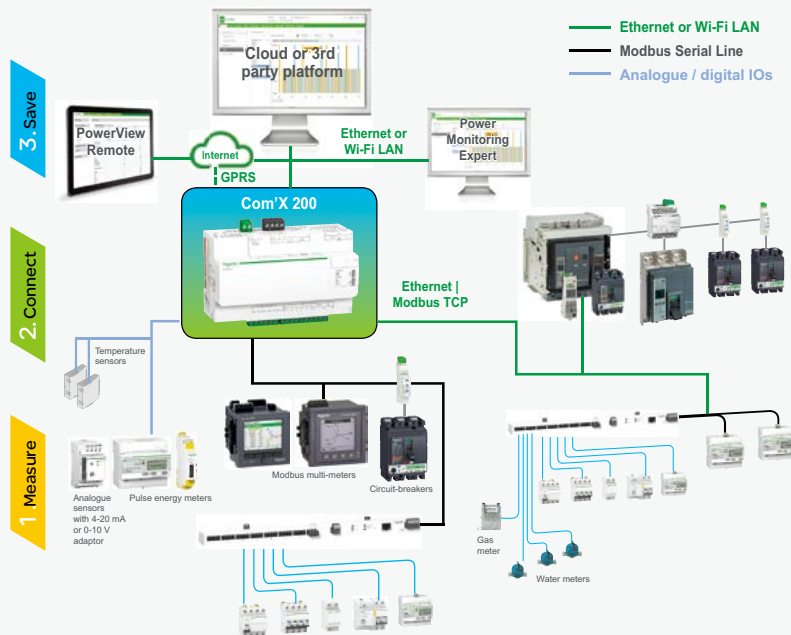

PB114856-200

Data collector

Collects and stores energy data from up to 64 field devices, connected to either:

- Ethernet TCP/IP field network.
- Modbus Serial line network (up to 32 devices).
- Embedded digital and analogue inputs.

“Field devices” consist of :

- PowerLogic devices for power and energy monitoring.
- Masterpact or Compact circuit-breakers for protection and monitoring.
- Acti9 protection devices, meters, remote controlled switches, etc.
- Water, Air, Gas, Electricity, and Steam (WAGES) consumption meters, from specialised manufacturers, delivering pulses as per standard (see table next page).
- Environmental sensors such as temperatures, humidity, and CO₂ levels in a building, providing analogue information.

Data logging and storage capabilities include:

- Configurable logging interval, from every minute to once a week.
- Data storage duration of several weeks, depending on quantity of collected data.

Data publisher

Batches of collected data periodically transmitted to an Internet server, as:

- XML files, for processing by EcoStruxure™ Power Management software products.
- CSV files for viewing in Excel or transformed for upload into programs such as EcoStruxure™ Power Monitoring Expert or any compatible software.

Data publishing function supports 4 transfer protocols over Ethernet or Wi-Fi:

- HTTP
- FTP
- HTTPS
- SMTP

Additional functions

Gateway

If selected by the user, the Com'X 210 can also make all data from connected devices available in real-time:

- In Modbus TCP/IP format over Ethernet or Wi-Fi.
- For requests by an energy management software.

Modbus packets can be sent from managing software to field devices through Modbus serial line or Modbus TCP/IP over Ethernet.

Commercial ref. no.	Product description
EBX210	Com'X 210 data logger 24 V DC or 230 V AC power supplied
EBXA-ANT-5M	Com'X External GPRS antenna

Com'X 510

A highly flexible plug-and-play Energy Server Com'X 510 collects and stores WAGES consumptions and environmental parameters such as temperatures, humidity and CO₂ levels in a building. The Com'X 510 has up to 2 year data storage and embedded webpages which means all your energy data can be viewed and managed on-site.

Applications

- All-in-one-box energy management solution especially suitable for buildings up to 10,000 sq. metres

PB114582

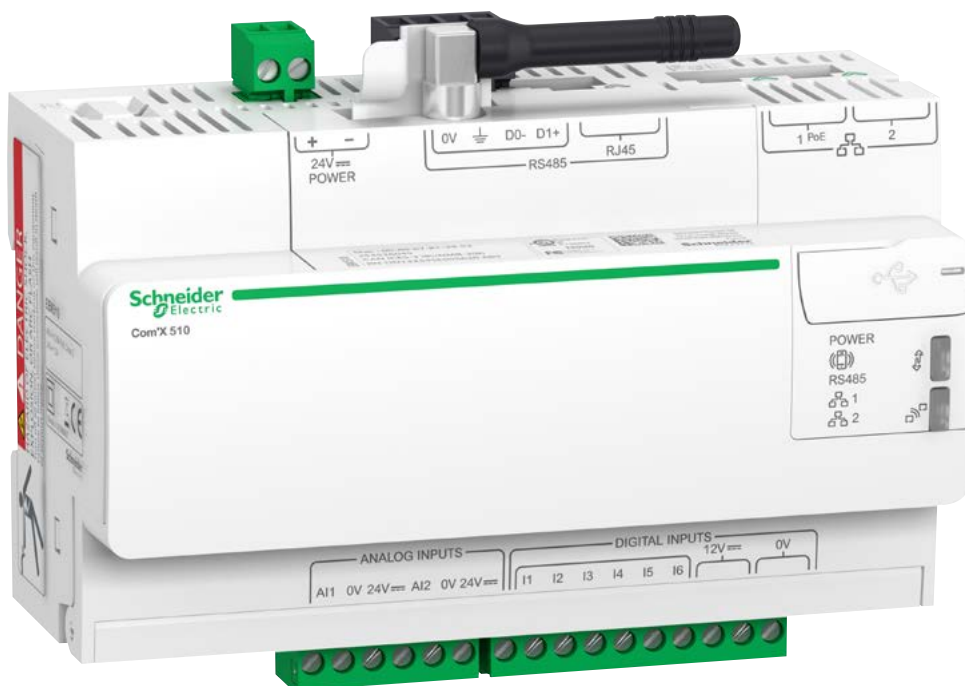

> [Com'X 510](#)

The solution for

All markets that can benefit from a solution that includes data logger Com'X 510:

- Buildings
- Industry

Benefits

- Data collection from up to 64 field devices
- Data publishing leveraging existing infrastructures : Ethernet or Wi-Fi, GPRS-ready
- Quick fitting into electrical switchboards thanks to DIN rail clipping and profile.
- Quick setup and configuration thanks to intuitive HMI

Competitive advantages

- Fit any PDU or RPP design for both new and retrofit projects
- Class 1.0 system accuracy
- Ethernet communication

Energy management solution

The data collected and stored by Com'X 510 can be processed and displayed through its own onboard webpage.

The Com'X 510 also provides a transparent interface between Ethernet-based networks and field devices. This gateway function supports the use of monitoring software, such as EcoStruxure™ Power Monitoring Expert for data collection, trending, event management, analysis and further processing.

Conformity of standards

- EN 60950

Architecture

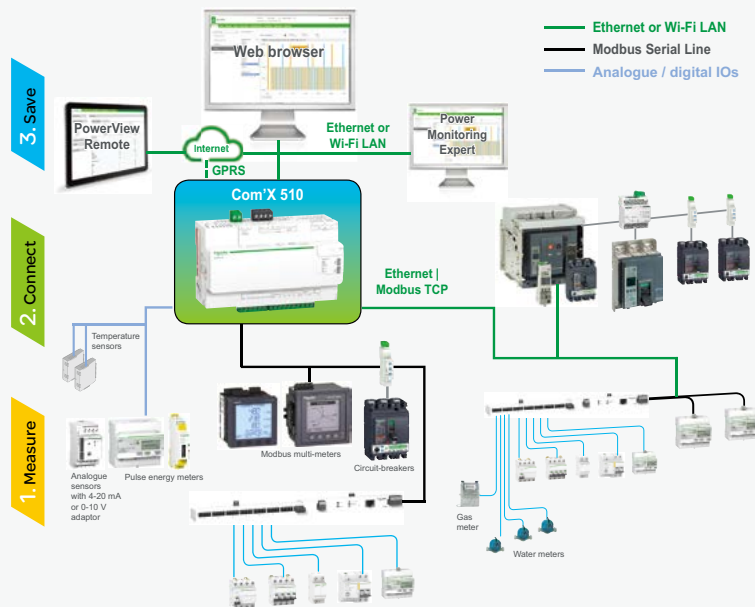

PB114856

Com'X 510 Energy server

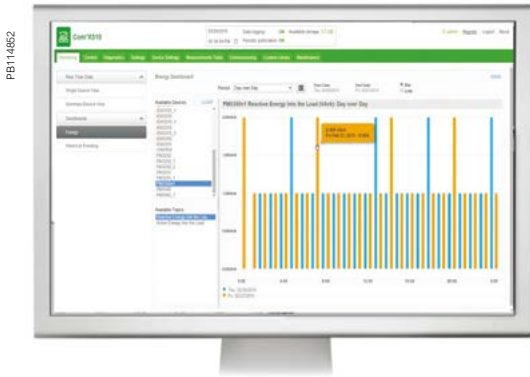

Energy dashboard comparing accumulated over time energy values (partial screen)

Data collector

As soon as the data logger is connected to the LAN, it can be detected and assigned an IP address by DHCP. Your operating system's DPWS feature allows your computer to automatically recognise the device as Com'X. Embedded web pages are then immediately accessible by clicking each Com'X device icon or by typing the assigned IP address into your web browser.

Collects and stores energy data from up to 64 field devices, connected to either:

- Ethernet TCP/IP field network.
- Modbus Serial line network (up to 32 devices).
- Embedded digital and analogue inputs.

“Field devices” consist of:

- PowerLogic meters for power and energy monitoring.
- Masterpact, Powerpact, or Compact circuit-breakers for protection and monitoring.
- Acti9 protection devices, meters, remote controlled switches, etc.
- Water, Air, Gas, Electricity, and Steam (WAGES) consumption meters, from specialised manufacturers, delivering pulses as per standard (see table at end of this document).
- Environmental sensors such as temperatures, humidity, and CO₂ levels in a building, providing analogue information.

Data logging and storage capabilities include:

- Data logging period: configurable from every minute to once a week.
- Data storage duration: up to 2 years, depending on quantity of collected data.
- Able to set time and send reset instructions to field devices.

Embedded energy management software

The Com'X provides the end-user with immediate visibility into energy consumption throughout the site. As soon as the Com'X is connected to the Local Area Network (LAN), several web pages are accessible via any standard web browser, (without plug-in or additional components).

These web pages display real-time data as it is collected, in easy to understand tabular and summary formats. In addition, users can get simple analysis of historical data in bar graph or trending formats.

Com'X 510 Energy server

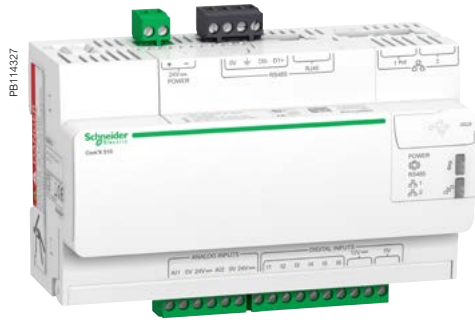

Energy Server Com'X 510 data logger

Additional functions

Data publisher

Batches of collected data can also be periodically transmitted to an Internet server, as:

- XML files, for processing by EcoStruxure™ Power Management software products
- CSV files for viewing in Excel or transformed for uploading to programs such as EcoStruxure™ Power Monitoring Expert or any compatible software

Data publishing function supports 4 transfer protocols over Ethernet or Wi-Fi:

- HTTP
- HTTPS
- FTP
- SMTP

Gateway

- If selected by the user, the Com'X 510 can make data from connected devices available in real time
- In Modbus TCP/IP format over Ethernet or Wi-Fi
- For requests by energy management software

Modbus packets can be sent from managing software to field devices through Modbus serial line or Modbus TCP/IP over Ethernet.

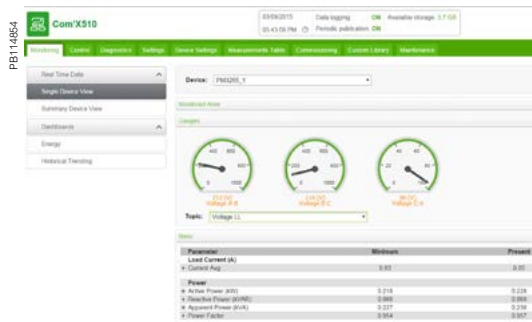

Raw data and measurements from one field device (partial screen)

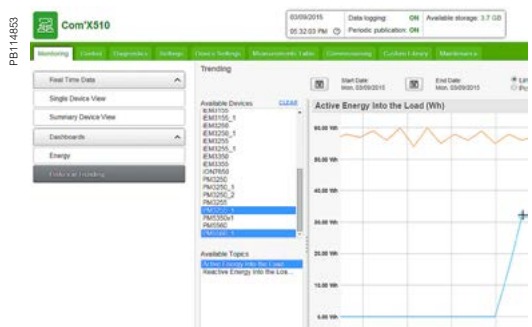

Historical trending comparing multiple devices or multiple topics (partial screen)

Commercial reference numbers	Description
EBX510	Com'X 510 energy server 24 V DC power supplied UL rated
EBXA-ANT-5M	Com'X External GPRS antenna
EBXA-USB-Zigbee	Com'X Zigbee USB interface

Com'X 210/510 Data Logger



Connection points

- | | |
|------------------|--------------------|
| 1 Terminal block | 3 Ethernet port #1 |
| 2 RJ45 cable | 4 Ethernet port #2 |



Power supply to analogue and digital inputs



GPRS modem



GPRS antenna

Connectivity

- Modbus SL / RS-485 connections to field devices
 - By cable with RJ45 connector.
- 2 Ethernet ports
 - Used to either separate upstream connection from field devices network or to daisy chain Ethernet devices.
 - RJ45 10/100BASE connectors.
 - Static IP address.
- Ethernet port #1
 - Connection to Local Area Network (LAN).
 - PoE Class 3 (802.3af) can act as main/backup power supply for the Com'X.
 - DHCP client.
- Ethernet port # 2
 - Connection to field devices.
 - DHCP client or server.
- Power supply to analogue and digital outputs
 - Outputs to supply sensors and inputs when Com'X is supplied through 24 V DC input on top:
 - 12 V DC 60 mA for digital inputs.
 - 24 V DC for analogue inputs.
 - Compliant with electrical switchboard environment (temperature, electromagnetic compatibility).
- 2 inputs for analogue sensors
 - PT100 or PT1000 temperature probes.
 - Various sensors (humidity, CO₂, etc.) with 0-10 V output.
 - Various sensors with 4-20 mA output
- 6 inputs for dry contact sensors or pulse counters
 - Max 25 pulses per second (min duration 20 ms)
 - IEC 62053-31 Class A
- GPRS modem
 - For connection to the data processing server through cellular or user's APN network.
 - Also connect to Schneider Electric's Digital Service Platform.
 - Especially suitable for sites with no internet access.
 - Simply plugs into dedicated port under the front cover.
- GPRS antenna
 - Improves GPRS signal strength in case of poor transmission conditions.
 - Recommended for Com'X located inside metallic electrical panels.

Com'X 210/510 setup and configuration

Setup and configuration

Connection to LAN

As soon as they are connected to the LAN, Com'X devices can be detected and assigned an IP address by DHCP. Your operating system's DPWS feature allows your computer to automatically recognise the device as Com'X. Embedded web pages are then immediately accessible by clicking each Com'X device icon or by typing the assigned IP address into your web browser.

Field device auto-discovery

The user-activated device discovery function automatically identifies all field devices connected to Modbus SL, Ethernet port.

- Schneider Electric devices display with the product image.
- Other devices appear as "unknown," allowing the user to manually assign a device type.
- User can assign their own device types.
- Users can complete additional device identification fields, such as circuit ID or building zone.

Data selection for logging and publication

Web page configuration tabs allow you to configure, in just a few clicks, which connected field devices collect and publish data.

- Advanced diagnostics and troubleshooting features
- Modbus serial and TCP/IP device statistics.
- Ethernet network statistics.
- Communications check wizard.
- Direct reading of register values from local and remote devices.

Additional features and benefits

- Cybersecurity - works well with your cyber security architecture.
- 2 Ethernet ports to separate upstream cloud connection, or to daisy chain with other Ethernet devices, from field device network.
- Data storage in case of communications failure.
- Local backup of configuration parameters - back up your system to a USB storage device and have it available for system restore or to duplicate the configuration on another box.

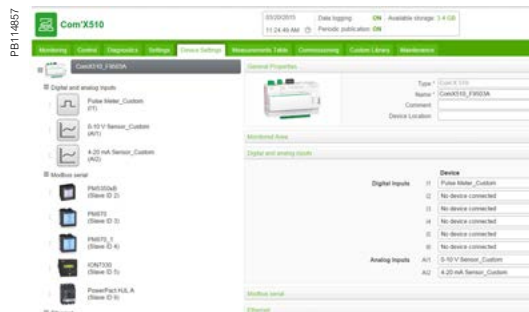

Device settings page (partial), as displayed after auto-discovery, enabling user to assign circuit identifications and select data for logging and publication.

Com'X 210/510 installation

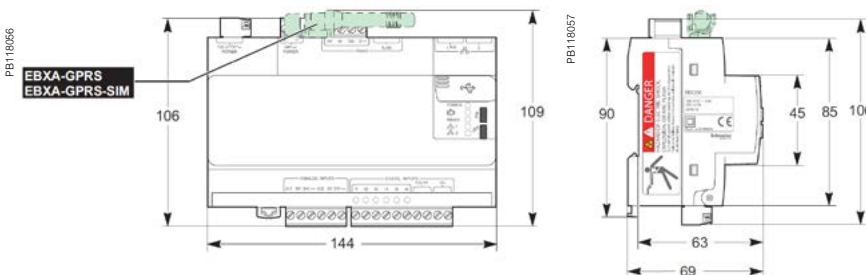

DIN rail fitting (Front face IP40, terminals IP20).

Com'X 210/510 Data Logger

Technical specifications			
Com'X 210/510 Environment			
Operating temperature	-25° to 60°C Com'X 210 -25° to 70°C Com'X 510		
Storage temperature	-40° to 85°C		
GPRS dongle Operating temperature	-20° to 60°C		
GPRS dongle Storage temperature	-40° to 85°C		
Wif-Fi dongle Operating temperature	0° to 50°C		
Wi-Fi dongle Storage temperature	-20° to 80°C		
Humidity	5 to 95 % relative humidity (without condensation) at 55°C		
Pollution	Class III		
Safety standards / regulation			
International (CB scheme)	IEC 60950		
USA	UL 508		
USA	UL 60950 (Com'X 510 only)		
Canada	cUL 60950 (Com'X 510 only)		
Canada	cULus 508		
Europe	EN 60950		
Quality Brands			
	CE, UL		
Power Supply		Com'X 210	Com'X 510
AC	100-230 V (+/- 15%)(50-60 Hz)	b	
DC	24 V (+/- 10%)	b	b
Power over Ethernet	15.4 W DC	b	b
Max power	26 W max	b	b
Mechanical		Com'X 210	Com'X 510
IP	Front face IP40, terminals IP20	b	b
Dimensions (HxWxD)	91 x 144 x 65.8 mm	b	b
Weight	450 g	b	b

ION7550 RTU

The PowerLogic ION7550 RTU (remote terminal unit) is an intelligent web-enabled device ideal for combined utilities metering of water, air, gas, electricity and steam (WAGES). When combined with Power management software, the ION7550 RTU offers a seamless, end-to-end WAGES metering solution.

Featuring a large, high-visibility display and overall versatility of the PowerLogic system, the ION7550 RTU provides extensive analogue and digital I/O choices and is a cost-effective dedicated WAGES solution when compared to a traditional meter. The device automatically collects, scales and logs readings from a large number of connected meters or transducers and delivers information to one or more head-end systems through a unique combination of integrated Ethernet, modem or serial gateways.

Applications

- WAGES (water, air, gas, electricity, steam) metering
- Integrated utility metering with advanced programmable math functions
- Data concentration through multi-port, multi-protocol communications
- Equipment status monitoring and control
- Programmable set points for out-of-limit triggers or alarm conditions



[> ION7550 RTU](#)

The solution for

All markets that can benefit from a solution that includes PowerLogic ION7550 RTU series meters:

- Buildings
- Industry
- Healthcare
- Education
- Etc.

Benefits

- Help reduce waste and optimise equipment operation to increase energy efficiency
- A large, intuitive display
- Extensive digital and analogue I/O
- Dedicated WAGES solution when compared to a traditional meter

Competitive advantages

- Data concentration through multi-port, multi-protocol communications
- Integrated utility metering with advanced programmable function

Power management solutions

As part of a complete enterprise energy management solution, the ION7550 RTU can be integrated with EcoStruxure™ Power Monitoring Expert, or other SCADA, information and automation systems.

Conformity of standards

- | | |
|-----------------|-----------------|
| • EN 61010-1 | • IEC 61000-4-4 |
| • IEC 61000-4-2 | • IEC 61000-4-5 |
| • IEC 61000-4-3 | • CISPR 22 |

Main characteristics

- Increase efficiency
 - Reduce waste and optimise equipment operation to increase efficiency.
- Easy to operate
 - Screen-based menu system to configure meter settings. Bright LCD display with adjustable contrast.
- Integrate with software
 - Easily integrated with PowerLogic or other energy management enterprises, including SCADA systems.
- Transducer and equipment condition monitoring
 - Versatile communications, extensive I/O points, clock synchronisation, event logging and sequence of events recording capabilities for transducer and equipment condition and status monitoring at utility substations.
- Set automatic alarms
 - Alarm setpoint learning feature for optimum threshold settings.
- Up to 10 Mbytes of memory
 - For archiving of data and waveforms.
- Notify alarms via email
 - High-priority alarms sent directly to the user's PC. Instant notification of power quality events by email.
- Modbus Master functionality
 - Aggregate and store data from downstream Modbus devices using serial or Ethernet connections

ION7550 RTU

1 2 3 4 5 6 7 8 9
M 7 5 5 0 A 0 N 9 B 9 A 0 A 0 A

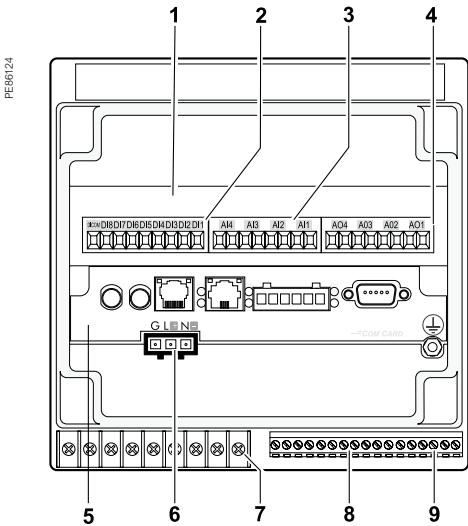

PowerLogic® ION7550 RTU.

- 1 I/O expansion card.
- 2 Digital inputs.
- 3 Analogue inputs.
- 4 Analogue outputs.
- 5 Communications card.
- 6 Power supply.
- 7 Form C digital outputs.
- 8 Digital inputs.
- 9 Form A digital outputs.

Part numbers

Item	Code	Description
1	Model	7550 ION7550 device
2	Form Factor	A0 Integrated display with front optical port, 5 MB logging memory, and 512 samples/cycle resolution.
		B0 Integrated display with front optical port, 10 MB logging memory, and 512 samples/cycle resolution.
		T0 Transducer (no display) version, with 5 MB logging memory.
		U0 Transducer (no display) version, with 10 MB logging memory.
3	RTU option	N9 RTU option
4	Power Supply	B Standard power supply (85-240 VAC, ±10%/47-63 Hz / 110-330 VDC, ±10%)
		C Low voltage DC power supply (20-60 VDC)
5	Internal use	9 This field for internal use only
6	Communications	A0 Standard communications (1 RS-232/RS-485 port, 1 RS-485 port). Integrated display models also include 1 ANSI Type 2 optical communications port.
		C1 Standard communications plus 10BASE-T/100BASE-TX Ethernet (RJ-45), 56k universal internal modem (RJ-11). Ethernet, modem gateway functions each use a serial port.
		D7 Standard comms plus 10BASE-T/100BASE-TX Ethernet (RJ-45) and 100BASE-FX Ethernet Fiber, 56k universal internal modem (RJ-11). Ethernet and modem gateway functions each use a serial communications port.
		E0 Standard communications plus 10BASE-T/100BASE-TX Ethernet (RJ-45). Ethernet gateway function uses serial port.
		F1 Standard communications plus 10BASE-T/100BASE-TX Ethernet (RJ-45) and 100BASE-FX (SC fiber optic connection). Ethernet gateway uses a serial port.
		M1 Standard communications plus 56k universal internal modem (RJ-11). Modem gateway uses serial communications port.
7	I/O	A Standard I/O (8 digital inputs, 3 Form C relays, 4 Form A solid-state outputs)
		E Standard I/O plus Expansion I/O card (8 additional digital inputs & four 0 to 20 mA analogue inputs)
		K Standard I/O plus Expansion I/O card (8 additional digital inputs & four 0 to 20 mA analogue outputs)
		N Standard I/O plus Expansion I/O card (8 additional digital inputs & four 0 to 20 mA analogue inputs and four 0 to 20 mA outputs)
		P Standard I/O plus Expansion I/O card (8 additional digital inputs & four 0 to 1 analogue inputs and four -1 to 1 mA analogue outputs)
8	Security	0 Password protected, no hardware lock
9	Special Order	A None
		C Tropicalisation treatment applied

ION7550 RTU

Commercial ref. no.	Communication Card for ION7550RTU
P765CA0A	Standard Comms: 1 RS-232/RS-485 port (COM1), 1 RS-485 port (COM2), Front optical port (COM3)
P765CA0C	Standard Comms: 1 RS-232/RS-485 port (COM1), 1 RS-485 port (COM2), Front optical port (COM3), tropicalisation treatment applied
P765CC1A	Standard plus Ethernet (10/100BASE-T), 56k universal internal modem (RJ11; shares COM3)
P765CC1C	Standard plus Ethernet (10/100BASE-T), 56k universal internal modem (RJ11; shares COM3), tropicalisation treatment applied
P765CD7A	Standard plus Ethernet (10/100BASE-T, 100BASE-FX), 56k internal modem (RJ11)
P765CD7C	Standard plus Ethernet (10/100BASE-T, 100BASE-FX), 56k internal modem (RJ11), tropicalisation treatment applied
P765CE0A	Standard plus Ethernet (10/100BASE-T)
P765CE0C	Standard plus Ethernet (10/100BASE-T), tropicalisation treatment applied
P765CF1A	Standard plus Ethernet (10/100BASE-T, 100BASE-FX)
P765CF1C	Standard plus Ethernet (10/100BASE-T, 100BASE-FX), tropicalisation treatment applied
P765CM1A	Standard plus 56k universal internal modem (RJ11; shares COM3)
P765CM1C	Standard plus 56k universal internal modem (RJ11; shares COM3), tropicalisation treatment applied
Commercial ref. no.	Analogue I/O cards
P760AEA	four 0 to 20 mA analogue inputs & 8 digital inputs
P760AEC	four 0 to 20 mA analogue inputs & 8 digital inputs, tropicalisation treatment applied
P760AKA	four 0 to 20 mA analogue outputs & 8 digital inputs
P760AKC	four 0 to 20 mA analogue outputs & 8 digital inputs, tropicalisation treatment applied
P760ANA	four 0 to 20 mA analogue inputs, four 0 to 20 mA analogue outputs & 8 digital inputs
P760ANC	four 0 to 20 mA analogue inputs, four 0 to 20 mA analogue outputs & 8 digital inputs, tropicalisation treatment applied
P760APA	four 0 to 1 analogue inputs, four -1 to 1 mA analogue outputs & 8 digital inputs.
P760APC	four 0 to 1 analogue inputs, four -1 to 1 mA analogue outputs & 8 digital inputs, tropicalisation treatment applied

ION7550 RTU

Commercial ref. no.	OpenDAC rack, controllers, power supply
70LRCK16-48	OpenDAC rack. Holds up to 8 OpenLine modules to provide up to 16 I/O points. Requires communications controller
72-MOD-4000	OpenDAC OpenDAC RS-485 serial module. Communications controller for use in a Modbus RTU network. Supports up to 2 70LRCK16-48 OpenDAC racks
72-ETH-T000	OpenDAC Ethernet network module for use on an Modbus/TCP Ethernet network. Supports up to 2 OpenDAC racks
PS-240-15W	85-264 V AC/110-370 V DC 15 W power supply. Required for applying power to the racks and controllers
Commercial ref. no.	OpenLine digital I/O modules
70L-IAC	digital input, 120 V AC
70L-IACA	digital input, 220 V AC
70L-IDC	digital input, 3-32 V DC
70L-IDCB	digital input, fast switching
70L-IDCNP	digital input, 15-32 V AC/10-32 V DC
70L-IDC5S	dry contact closure-sensing DC input
70L-ISW	input test module
70L-OAC	digital output, 120 V AC
70L-OACL	digital output, 120 V AC inductive loads
70L-OACA	digital output, 220 V AC
70L-OACAL	digital output, 220 V AC inductive loads
70L-ODC	digital output, 3-60 V DC fast
70L-ODCA	digital output, 4-200 V DC
70L-ODCB	digital output, fast switching
70L-ODC5R	digital output, dry contact
Ordering reference	OpenLine analogue I/O modules
73L-II020	analogue input, current, 0-20 mA
73L-II420	analogue input, current, 4-20 mA
73L-ITCJ	analogue input, temperature, J-type TC
73L-ITCK	analogue input, temperature, K-type TC
73L-ITCT	analogue input, temperature, T-type TC
73L-ITR100	analogue input, temperature, RTD
73L-ITR3100	analogue input, temperature, 3wire RTD
73L-ITR4100	analogue input, temperature, 4wire RTD
73L-IV1	analogue input, voltage, 0-1 V DC
73L-IV10	analogue input, voltage, 0-10 V DC
73L-IV10B	analogue input, voltage, -10 to 10 V DC
73L-IV100M	analogue input, voltage, 0-100 V DC
73L-IV5	analogue input, voltage, 0-5 V DC
73L-IV5B	analogue input, voltage, -5 to 5 V DC
73L-IV50M	analogue input, voltage, 0-50 mV
73L-OI020	analogue output, current, 0-20 mA
73L-OI420	analogue output, current, 4-20 mA
73L-OV10	analogue output, voltage, 0-10 V DC
73L-OV10B	analogue output, voltage, -10 to 10 V DC
73L-OV5	analogue output, voltage, 0-5 V DC
73L-OV5B	analogue output, voltage, -5 to 5 V DC

ION7550 RTU

Features	
	ION7550 RTU
Data recording	
Min/max of instantaneous values	b
Data logs	b
Event logs	b
Trending	b
SER (Sequence of event recording)	b
Time stamping	b
GPS synchronisation (1 ms)	b
Memory (in Mbytes)	10
Display and I/O	
Front panel display	b
Pulse output	1
Digital or analogue inputs(max)	24
Digital or analogue outputs (max, including pulse output)	30
Communication	
RS-485 port	1
RS-485 / RS-232 port	1
Optical port	1
Modbus TCP Master / Slave (Ethernet port)	b / b
Modbus RTU Master / Slave (Serial port)	b / b
Ethernet port (Modbus/TCP/IP protocol)	1
Ethernet gateway (EtherGate)	1
Alarms (optional automatic alarm setting)	b
Alarm notification via email (Meterm@il)	b
HTML web page server (WebMeter)	b
Internal modem	1
Modem gateway (ModemGate)	b
DNP 3.0 through serial, modem, and I/R ports	b

ION7550 RTU

Electrical characteristics		
Data update rate		1/2 cycle or 1 second
Power supply	AC	85-240 V AC \pm 10% (47-63 Hz)
	DC	110-300 V DC \pm 10%
	DC low voltage (optional)	20-60 V DC \pm 10%
	Ride-through time	100 ms (6 cycles at 60 Hz) min. at 120 V DC
	Burden	Standard: typical 15 VA, max 35 VA Low voltage DC: typical 12 VA, max 18 VA
Input/outputs ⁽¹⁾	Standard	8 digital inputs (120 V DC) 3 relay outputs (250 V AC / 30 V DC) 4 digital outputs (solid state)
	Optional	8 additional digital inputs 4 analogue outputs, and/or 4 analogue inputs
Mechanical characteristics		
Weight		1.9 kg
IP degree of protection (IEC 60529)		IP52
Dimensions	Standard model	192 x 192 x 159 mm
	TRAN model	235.5 x 216.3 x 133.1 mm
Environmental conditions		
Operating temperature	Standard power supply	-20 to 70°C
	Low voltage DC supply	-20 to 50°C
	Display operating range	-20 to 70°C
Storage temperature	Display, TRAN	-40 to 85°C
Humidity rating		5 to 95 % non-condensing
Installation category		III (2000 m above sea level)
Dielectric withstand		As per EN 61010-1, IEC 62051-22A ⁽²⁾
Electromagnetic compatibility		
Electrostatic discharge		IEC 61000-4-2
Immunity to radiated fields		IEC 61000-4-3
Immunity to fast transients		IEC 61000-4-4
Immunity to surges		IEC 61000-4-5
Conducted and radiated emissions		CISPR 22
Safety		
Europe		IEC 61010-1

(1) Consult the ION7550 / ION7650 installation guide for complete specifications.

(2) IEC 62051-22B with serial ports only.

ION7550 RTU

Communication	
RS-232/RS-485 port ⁽¹⁾	Up to 115,200 bauds (57,600 bauds for RS-485), ION, DNP 3.0, Modbus, GPS, EtherGate, ModemGate, Modbus Master
RS-485 port ⁽¹⁾	Up to 115,200 bauds, ION, DNP 3.0, Modbus, GPS, EtherGate, ModemGate, Modbus Master
Infrared port ⁽¹⁾	ANSI type 2, up to 19,200 bauds, ION, Modbus, DNP 3.0
Ethernet port	10BASET, 100BASETX. RJ45 connector, 10/100 m link
Fibre-optic Ethernet link	100BASE FX, SC duplex connector, 1300 nm, FO multimode with gradient index 62.5/125 µm or 50/125 µm, 2000 m link
Protocol	ION, Modbus, Modbus Master, TCP/IP, DNP 3.0, Telnet
EtherGate	Communicates directly with up to 62 slave devices via available serial ports
ModemGate	Communicates directly with up to 31 slave devices
WebMeter	5 customisable pages, new page creation capabilities, HTML/XML compatible
Firmware characteristics	
High-speed data recording	Down to 5 ms interval burst recording, stores detailed characteristics of disturbances or outages. Trigger recording by a user-defined setpoint, or from external equipment.
Load profiling	Channel assignments (800 channels via 50 data recorders) are configurable for any measurable parameter. Trigger recorders based on time interval, calendar schedule, alarm/event condition, or manually.
Trend curves	Access historical data at the front panel. Display, trend and continuously update historical data with date and timestamps for up to four parameters simultaneously.
Alarms	Threshold alarms: adjustable pickup and dropout setpoints and time delays, numerous activation levels possible for a given type of alarm user-defined priority levels boolean combination of alarms is possible using the operators NAND, OR, NOR and XOR
Advanced security	Up to 16 users with unique access rights. Perform resets, time syncs, or meter configurations based on user privileges
Memory	5 to 10 MB (specified at time of order)
Firmware update	Update via the communication ports
Display characteristics	
Integrated display	Backlit LCD, configurable screens
Languages	English

(1) All the communication ports may be used simultaneously.

ION7550 RTU

ION7550 RTU dimensions

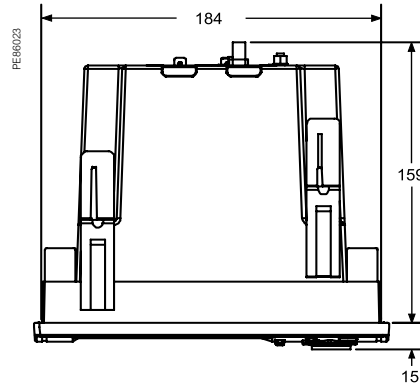
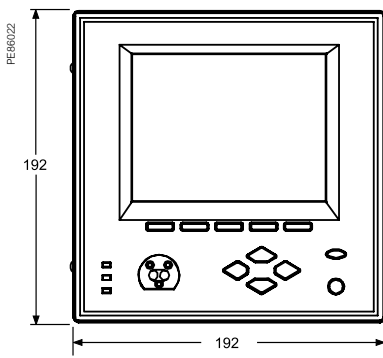

Front-panel mounting

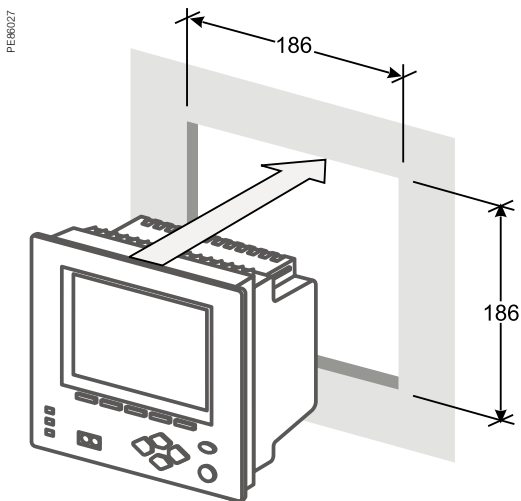

Power supply

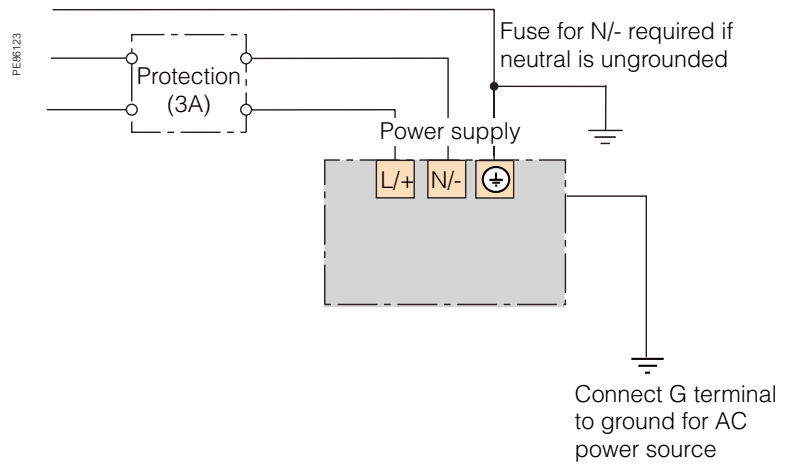

Note: the current and voltage terminal strip (I52, I51, I42, I41, I32, I31, I22, I21, I12, I11, V4, V3, V2, V1, Vref) is not present on the RTU.

Energy & Power Management Software



Overview

EcoStruxure Energy and Power management systems are especially designed to answer the needs of facilities where power is a critical asset, and where without power, lives or millions of dollars are at risk.

These systems provide facility managers with precise energy consumption data to drive energy accountability, sustainability, and savings. Your engineering manager will see power conditions at every critical point, and your maintenance personnel will use real-time status information to optimize equipment performance. And C-level executives will see the increase in productivity, profits, and ROI.

- EcoStruxure™ Power Monitoring Expert
- EcoStruxure™ Power SCADA Operation



> [Power Monitoring Expert](#)



> [Power SCADA Operation](#)

EcoStruxure™ Power Monitoring Expert

Reduce energy-related costs, increase reliability and availability, and optimize electrical equipment operations.

EcoStruxure Power Monitoring Expert is a complete, interoperable, and scalable purpose-built software dedicated to energy and power management. It enables you to track real-time power conditions, analyse power quality and network reliability, and lets you respond to alarms quickly. You can verify utility bill accuracy and reduce peak demand surcharges and power factor penalties. Pinpoint waste and allocate energy costs to departments to drive awareness and accountability..

Applications

EcoStruxure Energy and Power Management systems provide three main elements that fit together perfectly.

Electrical Network Management

- Electrical network monitoring
- Power quality monitoring
- Electrical network alarming
- Power event analysis

Cost Management

- Energy Monitoring
- Cost allocation
- Utility bill verification
- Energy usage analysis
- Energy targeting & forecasting
- Greenhouse gas reporting

Asset Management

- Breaker performance
- Capacity management
- Generator performance & compliance
- UPS performance

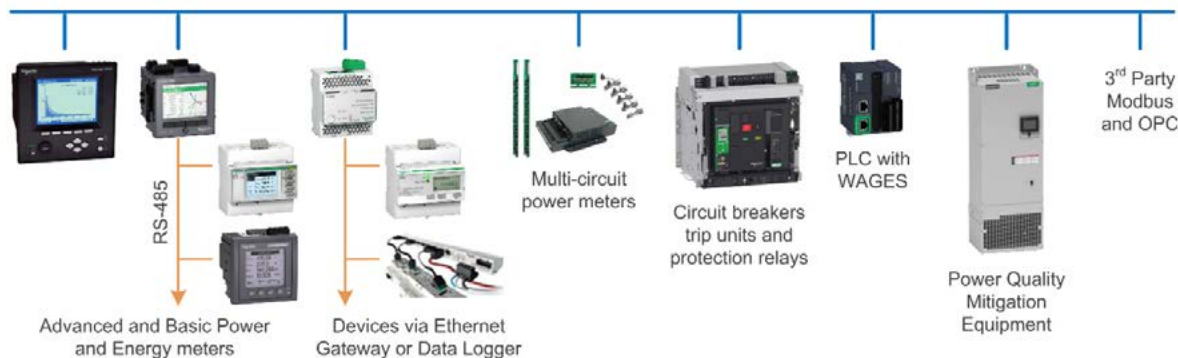

PB1180038

The solution for

Markets that can benefit from a solution that includes EcoStruxure™ Power Monitoring Expert:

- Healthcare
- Data Centres
- Buildings
- Industry
- Infrastructure
- Utility

Benefits

- Avoid outages, prevent equipment damage, optimize electrical system performance, and quickly assess power quality impacts.
- Improve energy efficiency to reduce operating cost, allocate energy cost to drive accountability and prevent unnecessary utility charges.
- Track and analyze equipment conditions, manage electrical capacity to ensure flexibility and get advanced warnings, wherever you are.

Competitive advantages

The best combination of scalability, flexibility and ease-of-use to deliver rich power and energy management applications. Including these unique and valuable features:

- Use Disturbance Direction Detection to quickly find the cause of faults.
- Power Quality KPIs help all stakeholders track progress in mitigation programs.
- Monitor breaker aging to avoid downtime due to aging equipment.
- Forecast energy expenses, validate energy efficiency investments and benchmark asset performance with modelling module.

Power management solutions

Schneider Electric provides innovative power management solutions to increase your energy efficiency and cost savings, maximise electrical network reliability and availability, and optimise electrical asset performance.

Conformity of standards

- ISO 50001/50002
- EN 50160
- IEC 61000-4-30
- IEEE 519
- ITIC/CBEMA/SEMI-F47

EcoStruxure™ Power Monitoring Expert

System architecture overview

EcoStruxure Power Monitoring Expert Natively communicates over Ethernet (IPv4 and IPv6) with a vast range of Schneider Electric devices and third-party products.

Data and analytics provided by EcoStruxure Power Monitoring Expert for centralized display, analysis, logging, alarming, event recording, and other processes can be accessed via web browser on a personal computer.

Features	
Real Time Monitoring	
Diagrams	<ul style="list-style-type: none"> Graphical monitoring and analysis application including electrical one-line diagrams, facility maps, plan views, floor layouts, equipment representations, and mimic displays. Comprehensive out of the box set of graphical device specific diagrams showing all relevant parameters from devices in the network.
Trends	<ul style="list-style-type: none"> Graphical charts for real-time trending of power usage (kW, Volt, Amp, and kWh) or any measurement supported by metered equipment such as generators and MV/LV switchgear.
Tables	<ul style="list-style-type: none"> Interactive side-by-side visualization of real-time measurements in a tabular format.
Alarm Management	
Advanced Alarm Viewer	<ul style="list-style-type: none"> Highly customizable alarm view for sequence of events and root cause analysis. Ability to filter on multiple parameters and save customized views for easy access to critical information.
Alarm Annunciator	<ul style="list-style-type: none"> Alarm annunciator provides a quick summary of the active alarms in the system. Breakdown of how many of alarms are high priority, medium priority, and low priority.
Alarm Notification	<ul style="list-style-type: none"> Ensure that appropriate staff members are notified of power system events. The system collects data, evaluate alarm conditions, and annunciate the alarms to specified users through email or SMS text messages.
Data Analytics & Visualization	
Dashboards	<ul style="list-style-type: none"> Interactive auto-updating dashboard views that may contain water, air, gas, electric, and steam (WAGES) energy summary data, historical data trends, images, and content from any accessible URL addresses. Users can create, modify, view, and share their dashboards.
Reports	<ul style="list-style-type: none"> Web-enabled reporting tool to view historical data in pre-formatted or user-defined report templates. The system supports reporting on all supported physical devices and virtual (or calculated) meters as defined in the device hierarchy. Users can to create, modify, view and share their reports in the web reports interface.
Calculation & Logic Engine	<ul style="list-style-type: none"> Graphical, object-oriented programming interface for creating system-wide, logical programs with arithmetic, data import, alarming and logging capabilities. Includes a comprehensive set of functions to create custom applications programs such as weather or real-time price import, KPI calculations, energy units conversion, data aggregation, data normalization, data comparison, power loss calculations, power factor control, load shedding, etc.
Optional Software Modules	
Electrical Network Management	<ul style="list-style-type: none"> Power Quality Performance Module. Power Capacity Module. Event Notification Module.
Cost Management	<ul style="list-style-type: none"> Energy Billing Module. Energy Analysis Module. Power Efficiency Module.
Asset Management	<ul style="list-style-type: none"> Breaker Performance Module. Generator Performance/EPSS Module. UPS Performances Module.

EcoStruxure™ Power Monitoring Expert



EcoStruxure™ Power Monitoring Expert dashboard (Hero page sample)



EcoStruxure™ Power Monitoring Expert dashboard (Energy Production sample)

Types of supported devices

EcoStruxure Power Monitoring Expert natively supports more than 80 Schneider Electric devices, including:

Power and energy meters:

- ION8800 Series
- ION7650/7550, ION7550 RTU
- PM5000 Series
- PM3000 Series (PM3250, PM3255)
- PM800 Series (PM810, PM820, PM850, PM870)
- iEM2000 Series (iEM2000, iEM2000T, iEM2010, iEM2105, iEM2110, iEM2135, iEM2150, iEM2155)
- iEM3000 Series (iEM3250, iEM3255)

PowerLogic branch circuit power meters:

- BCPM (A, B, C models)

Circuit breaker trip units:

- Micrologic X, A, E, P and H devices
- Micrologic Compact NSX Type A and Type E
- Smartlink

Protective relays:

- Sepam Series 10, 20, 40, 60, 80

Insulation monitors:

- Vigilohm IM20/20H

In addition, a library of more than 200 third-party device drivers is available. Ask your Schneider Electric representative for details.

Supported languages

English, Spanish, French, German, Chinese, Simplified Chinese, Polish, Czech, Italian and Russian (Other languages may be available - contact your Schneider Electric representative.)

Communication protocols and data exchange

EcoStruxure Power Monitoring Expert is designed to be easily integrated with third-party devices and systems:

- Modbus TCP and RTU
- ION Protocol
- OPC DA (Client and Server)
- SOAP based Web Services

Other data exchange technologies supported are:

- XML and CSV files
- OLEDB and ODBC
- ETL (Extract Transform Load)
- PQDIF and COMTRADE (Export only)

EcoStruxure™ Power Monitoring Expert

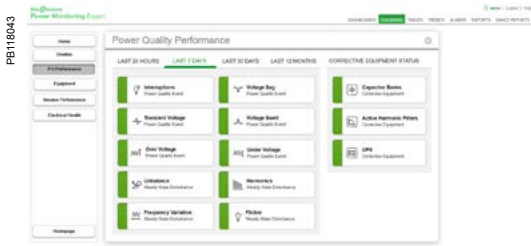

EcoStruxure™ Power Monitoring Expert dashboard (PQ Performance sample)



EcoStruxure™ Power Monitoring Expert dashboard (Trends sample)

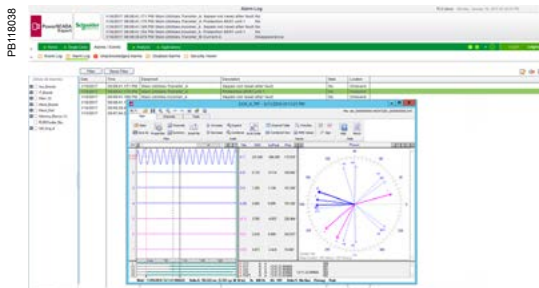

Software compatibility

Operating systems:

- Windows 7 Professional/Enterprise, SP1
- Windows 8.1 Professional/Enterprise
- Windows 10 Professional/Enterprise
- Windows Server 2008 R2 Standard/Enterprise, SP1
- Windows Server 2012 Standard/Enterprise
- Windows Server 2012 R2 Standard
- Windows Server 2016 Standard

SQL server:

- Windows 7 Professional/Enterprise, SP1
- SQL Server 2008 R2 Express/Standard/Enterprise, SP3
- SQL Server 2012 Express/Standard/Enterprise/Business Intelligence, SP3
- SQL Server 2014 Express/Standard/Enterprise/Business Intelligence, SP1 SP2
- SQL Server 2016 Express/Standard/Enterprise/Business Intelligence, SP1

Browsers supported:

- Windows 7 Professional/Enterprise, SP1
- Microsoft Internet Explorer versions 10 and 11
- Microsoft Edge
- Google Chrome version 42 and later
- Mozilla Firefox version 35 and later
- Apple Safari versions 7 or 8 and later versions, respectively, on Mac computers

ISO 50001/50002 Certified

EcoStruxure Power Monitoring Expert support compliance with the requirements of the standards ISO 50001 and ISO 50002.

EcoStruxure™ Power SCADA Operation

Real-time insights, knowledge, and control: this is how our high-speed data-acquisition monitoring and management software increases power availability in your mission-critical electrical distribution networks.

Perfect for even the most demanding facility. Its intuitive, interactive, and customizable interface provides practical information: detailed alarming, real-time monitoring and control, and power-related visualization tools. It integrates seamlessly with your electrical systems and easily scales to evolve with your needs.

Applications

An excellent fit for virtually every industry and application, EcoStruxure™ Power SCADA Operation delivers exceptional scalability so that it can grow to meet your multiple, changing business requirements while driving down the total cost of ownership.

PB1143827

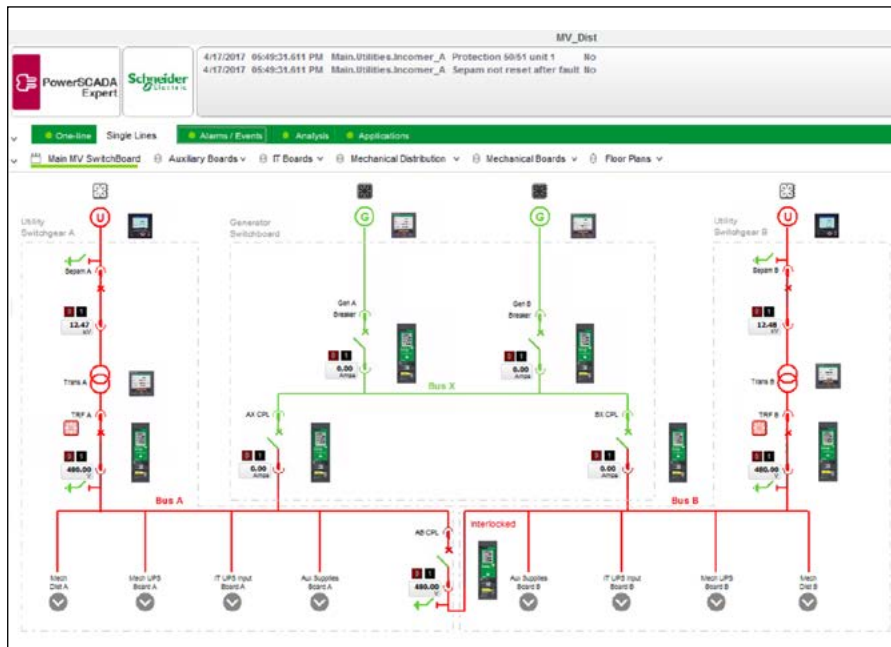

The solution for

Markets that can benefit from a solution that includes EcoStruxure™ Power SCADA Operation:

- Healthcare
- Data Centres
- Buildings
- Industry
- Infrastructure
- Utility

Benefits

- Dynamic electrical network views to maximize facility uptime and reduce energy costs
- Makes energy and power quality immediately relevant and actionable to support your operational and sustainability goals

Competitive advantages

- Highly reliable monitoring and control tailored to unique electrical network needs.
- High performance alarming and notification to manage your complex power system.
- Reporting and dashboards module with comprehensive energy and power templates to deliver powerful analytics.
- Disturbance waveform viewer to facilitate power quality analysis and root cause analysis.

Power management solutions

Schneider Electric provides innovative power management solutions to increase your energy efficiency and cost savings, maximise electrical network reliability and availability, and optimise electrical asset performance.

Conformity of standards

- ISO 50001

EcoStruxure™ Power SCADA Operation



EcoStruxure™ Power SCADA Operation dashboard

EcoStruxure™ Power SCADA Operation is a reliable, flexible and high performance monitoring and control solution designed to reduce outages and increase power efficiency. It is built to handle user requirements from the smallest to the most demanding enterprises, while still providing high time performance and reliability. Easy-to-use configuration tools and powerful features enable faster development and deployment of any size of application.

Object-based, standard graphics and symbols provide operators with an interactive and user-friendly interface. Intuitive commands and controls increase efficiency of operators to interact with the system interface. EcoStruxure™ Power SCADA Operation controls your system with high reliability, performance and data integrity through the use of advanced architectures, such as hot/hot redundant I/O device configurations, self-healing ring communications, and primary and standby server configurations. Comprehensive user-based security is integrated into all interface elements, ensuring a cyber resilient control system.

- Typical applications

- EcoStruxure™ Power SCADA Operation software has the following applications:
 1. Power Monitoring and Control - Notify in real time when deviations from normal operating conditions occur and control electrical equipment safely and reliably in response to these conditions.
 2. Power Availability – Improve continuity of electrical system by identifying root causes of problems to quickly recover power and avoid future outages.
 3. Energy Monitoring – Establish baseline energy usage, set reduction targets, adjust operations for continuous improvements.

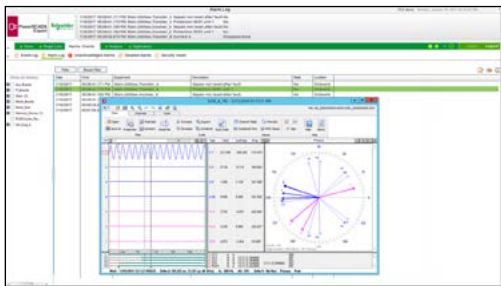

Waveform viewer dashboard (sample)

- System architecture

- Human machine interface (HMI)
 - EcoStruxure™ Power SCADA Operation offers secure, operator-dedicated, multi-user data and control access through a local server interface, full control client and also through web clients.

- Main components

- SCADA software
 - Drivers, libraries and communication tools.
 - Use these components to configure your SCADA network, including communication paths, devices and logical groups.

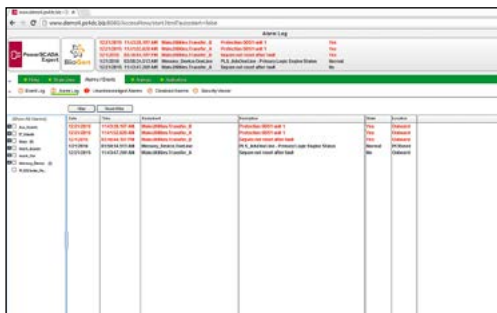

Alarms report dashboard (sample)

- Functional components of EcoStruxure™ Power SCADA Operation

- Includes gateways, PLCs, RTUs, switches, etc.
- Redundant, self-healing ring, double-ring technology.
- Design reference guide.
- Design of architectures to achieve time performance & reliability.
- Schneider Services.
 - Pro-active assistance to facility maintenance team for sensitive electrical distribution maintenance operations.

- Data acquisition and management

- Redundant I/O server
- Hot/hot standby: data acquisition is never interrupted even if one server fails.
- Distributed, multiple server architecture with corresponding configuration tools.
- IEC61850 compliant databases.
- Designed for interoperable exchange of data for distributed substation automation systems and third-party devices.
- Supports data import/export with compliant devices and systems.

- Data acquisition and integration

EcoStruxure™ Power SCADA Operation

PB118037

Typical EcoStruxure™ Power SCADA Operation architecture

- Integrate electrical distribution devices with PLCs, RTUs, Controllers and other intelligent energy devices. Native, out-of-the-box support for all Sepam Series 20, 40, 80, and Sepam 2000 (S36), PowerPact, Compact NSX, Masterpact NT/NW, Masterpact MTZ with communicating Micrologic Trip/Base Units,
- ION7650, PM8000, PM5000 series and BCPM . Enables access to meter data, digital outputs and remote configuration. Interface with PLCs, RTUs and power distribution equipment. Quickly add and configure devices with easy-to-use I/O Device Wizard and Profile Editor. Scalable platform enables remote devices and user clients to be added as needs grow while maintaining your original investment. Integrate with other energy management or automation systems through Modbus TCP/IP.
- Alarms and events
 - EcoStruxure™ Power SCADA Operation software allows you to receive alerts to outages or impending problems that could lead to equipment stress, failures, or downtime. Configure alarms to trigger on events, power thresholds, or equipment conditions. The software logs complete information on an event, including related coincident conditions, all with accurate 1ms timestamping.
 - Easily segregate alarm criticality levels.
 - High speed alarm response. Capture and log every single alarm or event.
 - Organise, filter and print by any alarm property. Configure specific alarm occurrences to change symbol color or flash an icon on a page.
 - View the five most recent alarms from every page, providing detailed information in easy-to-understand formats.
 - Event log for all PC-based and on-board field events, alarms.
 - Easily configure to annunciate based on alarm type.
- Standards supported
 - IEC 61850
 - DNP3
 - ION
 - Modbus
 - IEC 60870-5-104
 - BACnet/IP
 - SNMP
- Electrical distribution control
 - Perform fast, manual control operations by clicking on-screen buttons to operate remote breakers, protection relays, and other power distribution equipment.
- Real-time monitoring
 - View all distribution points across your network. Secure display of real-time power and energy measurements, historical trends and data logs, alarm conditions, equipment status (on/off, temperature, pressure, etc.), control triggers, and analysis tools.
 - One line diagrams with real-time monitoring and control of devices, objects and distribution points. Point-and-click navigation reveals deeper layers of detail.
 - IEC and ANSI-standard symbols and templates that are fully animated and interactive, to blend control and display functionality.
 - Dynamic colouring is easily configured using the default set or user-defined colours and voltage levels.
 - True color, easy-to-use human machine interface (HMI) that provides operators with intuitive and consistent screens

EcoStruxure™ Power SCADA Operation

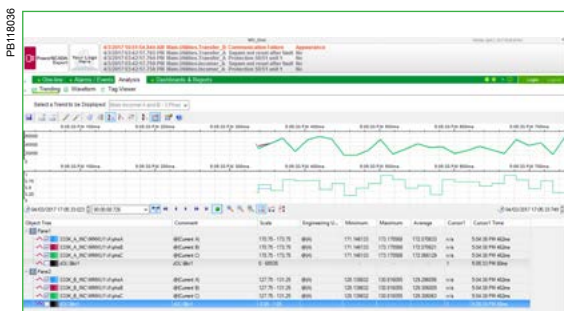

Power SCADA Operation sample Trends display

- Analysis
 - Trend and analyse on any measured parameter, allowing operators to recognise patterns that may lead to disturbances. Display millisecond-accurate historical alarms and trends to help determine the sequence of events or root cause analysis. Unite trend and alarm data for sophisticated disturbance views and analysis.

User-defined colour coding and overlays clearly highlight data series, time ranges, thresholds and limits. View COMTRADE waveforms, record, save or export trends to archives. Supported protocols include: Schneider Electric devices with WFC capabilities via Modbus and ION and 3rd party devices via IEC-61850 with compliant COMTRADE WFC capabilities.
- Configuration tools
 - EcoStruxure™ Power SCADA Operation is supplied with a package of configuration tools designed to make set up uniquely easy and quick.
 - Designed to help make project set up and network configuration fast and easy.
 - Profile Editor provides standard device types and their associated profiles and allows engineers to easily customise the profiles of the devices specific to the project. New export/import capability allows easier sharing of profiles.
 - Standardized tags per device profile (configurable), XML file
 - Creates, adds, edits device types, tags and profiles.
 - I/O Device Manager provides a standard interface for quick SCADA data base generation:
 - Instantiation of devices, on a per object basis.
 - Creates tags, trends, alarms and events when devices are added to system.
 - Batch editing supported by automation interface.
- Minimum system requirements

(Consult your local Schneider Electric representative for complete system requirements and commissioning information for EcoStruxure™ Power SCADA Operation). The following are minimum support requirements with factory default settings.

 - Runs on standard PCs or servers, and supports the following operating systems: Windows Server 2016, Windows 10, Windows Server 2012 R2, Windows 8.1, Windows Server 2012, Windows 8, Windows 2008 R2 and Windows 7
- Supported devices and protocols
 - PowerLogic electrical network protection:
 - Sepam series 20, 40, 80, Sepam 2000 (S36)
 - PowerLogic power and energy meters:
 - ION7650, PM8000, PM5000 series
 - Circuit breaker control units
 - PowerPact, Compact NSX, Masterpact NT/NW, Masterpact MTZ with communicating Micrologic Trip/Base Units
 - Branch circuit monitors: BCPM
 - Native device protocol support: IEC 61850 Edition 1, DNP3, ModBus TCP/IP, SNMP, IEC 80750-5-104, ION, BACnet
 - IEC 80750-5-104 b ION, BACNet,
 - Data access (Other protocols support): OPC DA version 2 client & server, OPC AE version 1.0 server, ODBC
 - Other: Any PLC or other device via Modbus protocol

Current transformers



Overview

Schneider Electric is the global specialist in energy management with the most complete power monitoring product line. From simple indicators (analog meters) and CTs, to world class energy meters and powerful compact power meters, these proven products satisfy any requirement.

056854NMD-2
056852NMD-2
PE100316-35

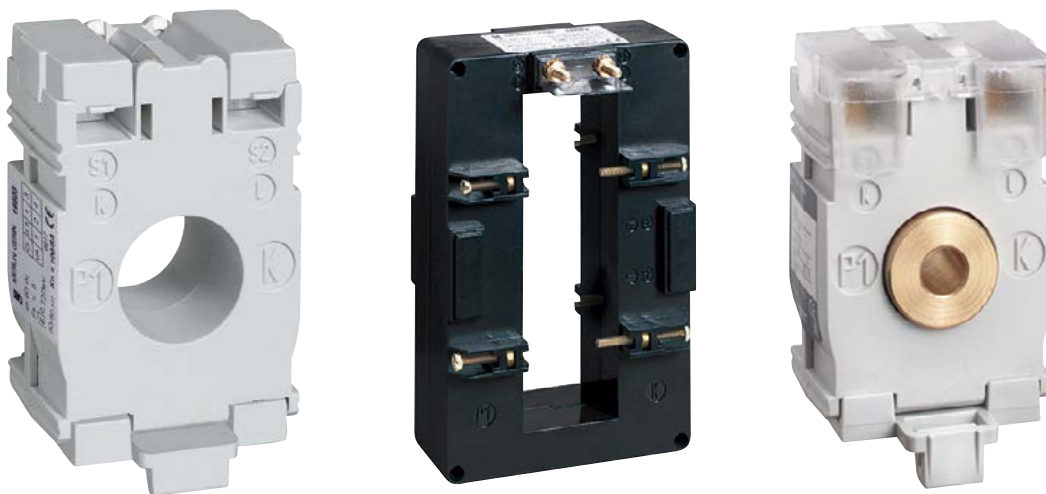

CT current transformers

Ip/5 A ratio

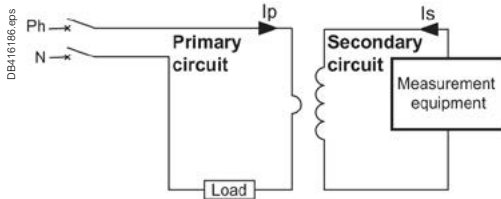

Application diagram of a CT.

The Ip/5 A ratio current transformer delivers at the secondary a current (I_s) of 0 to 5 A that is proportional to the current measured at the primary (I_p). This allows them to be used in combination with measurement equipment:





- Ammeters.
- Kilowatt-hour meters.
- Measurement units.
- Control relays.
- etc.

When the primary is energized, the measurement equipment nearly acts as a short circuit which keeps the secondary voltage very low. This voltage will increase significantly if the short circuit is removed.

CT selection - conductor rating aspects

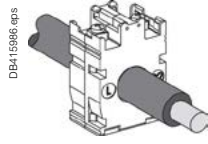
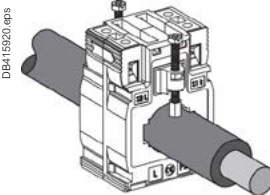
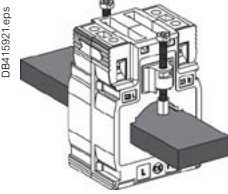
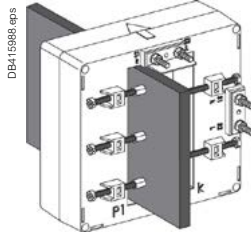
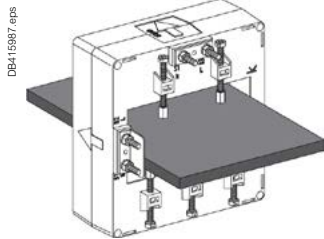
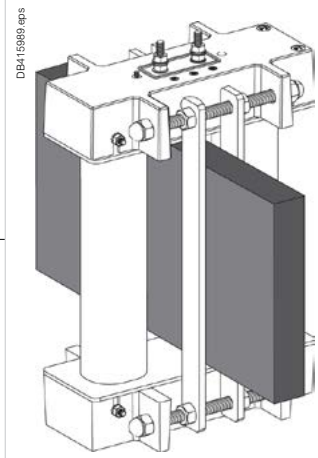
The choice depends on the conductor profile and the maximum intensity of the primary circuit.

CT with let-through primary

Conductor type	Cable	Mixed, bars or cables	Vertical or horizontal bars	Vertical bars
Suggested Current Transformer and mounting		 	 	
Ratings (A)	40 to 250	150 to 800	200 to 4000	5000 to 6000
CT internal	Type C	Type M	Type D ⁽¹⁾	Type V
				

(1) Two secondary connectors (parallel internal wiring - only one secondary winding) for easier cable access. 1 lateral + 1 on one extremity. Warning: only one must be used at a time.

Specific mounting: use of cylinder

A cylindrical metallic spacer ensures a proper CT positioning when the conductor or the CT cannot be positioned perpendicular. Secured by bolt + nut.

CT with primary connection by screw and nut (example: use of cylinder with bar or cable)

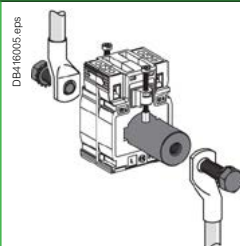

METSECT5CYL1 (aluminium)

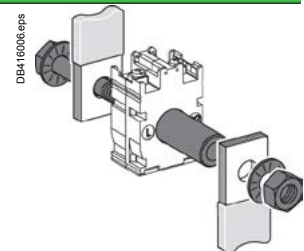

16550 (brass)

See appropriate Installation Guide for these products.

CT selection - Electrical aspect Ip/5 A

- We recommend that you choose the ratio immediately higher than the maximum measured current (In).
Example: In = 1103 A; ratio chosen = 1250/5.
- For small ratings: From 40/5 to 75/5 and for an application with digital devices, we recommend that you choose a higher rating, for example 100/5. This is because small ratings are less accurate and the 40 A measurement, for example, will be more accurate with a 100/5 CT than with a 40/5 CT.
- Specific case of the motor starter: to measure motor starter current, you must choose a CT with primary current $I_p = I_d/2$ (I_d = motor starting current).

Validation of measurement solution according accuracy class

It consists in controlling the right adaptation of the CT on the accuracy class aspect. The accuracy class is specified in the project. The total dissipated power of the measurement circuit (meter + cables) should not be superior to the specified limit of the CT. This limit is for different standard classes. If necessary, the choice of the cable section, the CT or meter should be modify to fit the requirement.

Copper cable cross-section (mm ²)	Power per doubled meter at 20 °C (VA)	Schneider Electric device	Consumption of the current input (VA)
1	1	Ammeter 72 x 72 / 96 x 96	1.1
1.5	0.685	Analog ammeter	1.1
2.5	0.41	Digital ammeter	0.3
4	0.254	PM8000	0.15
6	0.169	PM3000	0.3
10	0.0975		
16	0.062		

For each temperature variation per 10 °C bracket, the power drawn up by the cables increases by 4 %.

Application example

Project specification: 200 A, in Ø27 mm cable, accuracy class 1.
Our choice is METSECT5MA020.

For this CT selected on the chart (next page), the max acceptable power is 7 VA (for "Accuracy class 1" which is specified in the project).

Internal profile type	Cables (mm)	Bars (mm)	Rating Ip/5 A (A)	Commercial reference number	Accuracy class		
					0.5	1	3
					Max. power (VA)		
	Ø27	10 x 32 15 x 25	150	METSECT5MA015	3	4	-
			200	METSECT5MA020	4	7	-
			250	METSECT5MA025	6	8	-
			300	METSECT5MA030	8	10	-
			400	METSECT5MA040	10	12	-

Control of the conformity of the measurement chain:
 b PM3000 multi-meter: 0.3 VA.
 b 4 meters of 2.5 mm², doubled wires: 0.41 x 4 = 1.64 VA.

Total: 0.3 + 1.64 = 1.94 VA (< 7 VA)

Conclusion: this CT is well adapted as the accuracy class will be even better than 1.

PB112465

Presentation of commercial reference numbers

MET SE CT **X** **XX** **XXX**

1 = 1 Amp
5 = 5 Amp
R = Rogowski

Last 3 digits = primary rating/10
2 letters = Form Factor

Examples:

METSECT5CC008 = 5 A secondary, Cables only, 75 A primary

METSECT5MC080 = 5 A secondary, mixed for cables and bars, 800 A primary

METSECTR30500 = Rogowski CT, 300 mm length, 96 mm diameter 50 A to 5000 A

PB112446



METSECT5CCppp

PB112461



METSECT5MBppp

PB112460



METSECT5MAppp

PB112462



METSECT5MCppp

PB112463



METSECT5MDppp

Type C - current transformer (cable profile)				
Internal profile type	Cables (mm)	Bars (mm)	Rating Ip/5 A (A)	Commercial reference number
CC				
	Ø21	-	40	METSECT5CC004
			50	METSECT5CC005
			60	METSECT5CC006
			75	METSECT5CC008
			100	METSECT5CC010
			125	METSECT5CC013
			150	METSECT5CC015
			200	METSECT5CC020
		250	METSECT5CC025	

Type M - current transformers (mixed: cable/bar profile)				
MB				
	Ø26	12 x 40 15 x 32	250	METSECT5MB025
			300	METSECT5MB030
			400	METSECT5MB040
MA				
	Ø27	10 x 32 15 x 25	150	METSECT5MA015
			200	METSECT5MA020
			250	METSECT5MA025
			300	METSECT5MA030
			400	METSECT5MA040
MC				
	Ø32	10 x 40 20 x 32 25 x 25	250	METSECT5MC025
			300	METSECT5MC030
			400	METSECT5MC040
			500	METSECT5MC050
			600	METSECT5MC060
			800	METSECT5MC080
MD				
	Ø40	12 x 50 20 x 40	500	METSECT5MD050
			600	METSECT5MD060
			800	METSECT5MD080

See your Schneider Electric representative for complete ordering information.

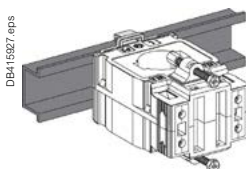
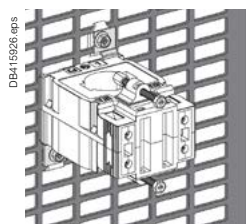

Common characteristics	
Secondary current Is (A)	5 A
Maximum voltage rating Ue (V)	720 V
Frequency (Hz)	50/60 Hz
Safety factor (sf)	40 to 4000 A: sf y 5 5000 to 6000 A: sf y 10
Degree of protection	IP20
Operating temperature	tropicalised range -25°C to +60°C ⁽¹⁾ relative humidity > 95 %
Storage temperature	-40°C to +85°C
Compliance with standards	IEC 61869-2 VDE 0414
Secondary connection (as per model)	by terminals for lug by tunnel terminals by screws

(1) Warning: some products are limited to +50°C.

DIN rail mounting.

Type C - current transformer (cable profile)							
Internal profile type	Accuracy class			Overall dimensions (refer to drawing pages for details) W x H x D (mm)	Fastening mode	Accessories Cylinder	
	0.5	1	3				
	Max. power (VA)						
CC							
	-	-	1	44 x 66 x 37	b Adapter for DIN rails. b Mounting plate.	16550 METSECT5CYL1	Included
	-	1.25	1.5				
	-	1.25	2				
	-	1.5	2.5				
	2	2.5	3.5				
	2.5	3.5	4				
	3	4	5				
4	5.5	6					
5	6	7					
MB							
	3	4	-	60 x 85 x 63	b Adapter for DIN rails. b Mounting plate.	-	METSECT5COVER
	4	6	-				
	6	8	-				
MA							
	3	4	-	56 x 80 x 63	b Adapter for DIN rails. b Mounting plate.	METSECT5CYL2	METSECT5COVER
	4	7	-				
	6	8	-				
	8	10	-				
	10	12	-				
MC							
	3	5	-	70 x 95 x 65	b Adapter for DIN rails. b Mounting plate.	-	METSECT5COVER
	5	8	-				
	8	10	-				
	10	12	-				
	12	15	-				
10	12	-					
MD							
	4	6	-	70 x 95 x 65	b Adapter for DIN rails. b Mounting plate.	-	METSECT5COVER
	6	8	-				
	8	12	-				

See your Schneider Electric representative for complete ordering information.



METSECT5VVppp

Type V - current transformers (vertical bar profile)				
Internal profile type	Cables (mm)	Bars (mm)	Rating Ip/5 A (A)	Commercial reference number
VV				
	-	55 x 165	5000	METSECT5VV500 g
			6000	METSECT5VV600 g



METSECT5DAppp

METSECT5DBppp

Type D - current transformers (vertical or horizontal bar - dual secondary terminals)				
DA				
	-	32 x 65	400	METSECT5DA040
			500	METSECT5DA050
			600	METSECT5DA060
			800	METSECT5DA080
			1000	METSECT5DA100
			1250	METSECT5DA125 g
			1500	METSECT5DA150 g
DB				
	-	38 x 127	1000	METSECT5DB100
			1250	METSECT5DB125 g
			1500	METSECT5DB150 g
			2000	METSECT5DB200 g
			2500	METSECT5DB250 g
			3000	METSECT5DB300 g
DC				
	-	52 x 127	2000	METSECT5DC200 g
			2500	METSECT5DC250 g
			3000	METSECT5DC300 g
			4000	METSECT5DC400 g
DD				
	-	34 x 84	1000	METSECT5DD100
			1250	METSECT5DD125 g
			1500	METSECT5DD150 g
DE				
	-	54 x 102	1000	METSECT5DE100
			1250	METSECT5DE125 g
			1500	METSECT5DE150 g
			2000	METSECT5DE200 g
DH				
	-	38 x 102	1250	METSECT5DH125 g
			1500	METSECT5DH150 g
			2000	METSECT5DH200 g



METSECT5DCppp

METSECT5DDppp

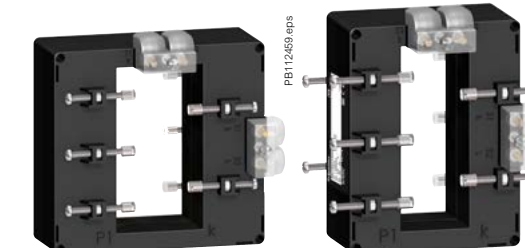

METSECT5DEppp

METSECT5DHppp

g Operating temperature: -25 °C to 50 °C

See your Schneider Electric representative for complete ordering information.

Type V - current transformers (vertical bar profile)

Internal profile type	Accuracy class			Overall dimensions (refer to drawing pages for details) W x H x D (mm)	Fastening mode	Accessories	
	0.5	1	3			Cylinder	Sealable cover
	Max. power (VA)						
VV							
	60	-	-	175 x 273.5 x 110	b Insulated locking screw.	-	Included
	70	-	-				

Type D - current transformers
(vertical or horizontal bar - dual secondary terminals)

DA							
	4	8	-	90 x 94 x 90	b Insulated locking screw.	-	Included
	8	10	-				
	8	12	-				
	12	15	-				
	15	20	-				
	15	20	-				
20	25	-					
DB							
	6	10	-	99 x 160 x 87	b Insulated locking screw.	-	Included
	8	12	-				
	10	15	-				
	15	20	-				
	20	25	-				
	25	30	-				
DC							
	25	30	-	125 x 160 x 87	b Insulated locking screw.	-	Included
	30	50	-				
	30	50	-				
	30	50	-				
DD							
	10	15	-	96 x 116 x 87	b Insulated locking screw.	-	Included
	12	15	-				
	15	20	-				
DE							
	12	15	-	135 x 129 x 85	b Insulated locking screw.	-	Included
	15	20	-				
	20	25	-				
	20	25	-				
DH							
	12	15	-	98 x 129 x 75	b Insulated locking screw.	-	Included
	12	15	-				
	20	25	-				

^g Operating temperature: -25 °C to 50 °C

See your Schneider Electric representative for complete ordering information.

CT current transformers dimensions

CC internal profile type

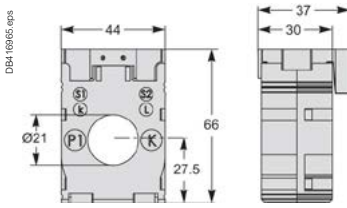

MB internal profile type

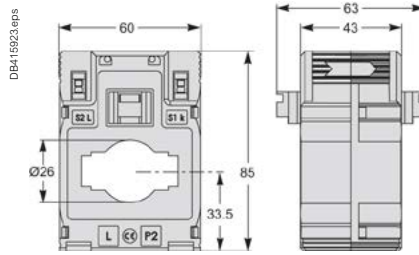

MA internal profile type

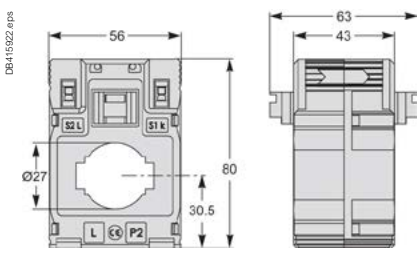

MC internal profile type

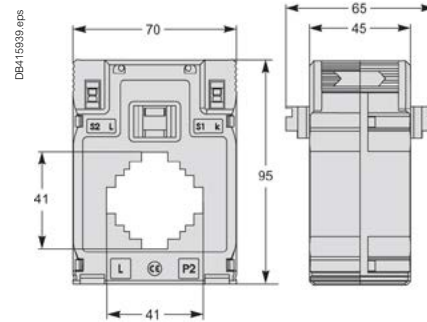

MD internal profile type

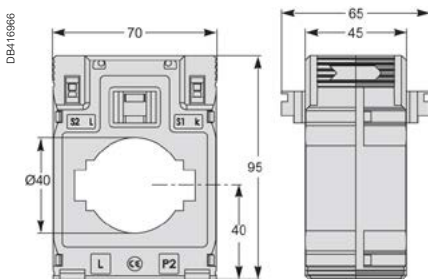

DA internal profile type

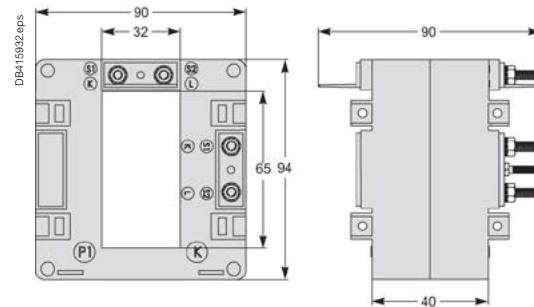

DB internal profile type

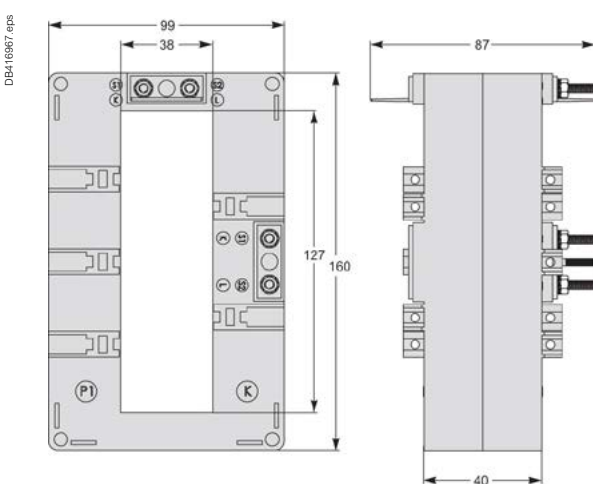

DC internal profile type

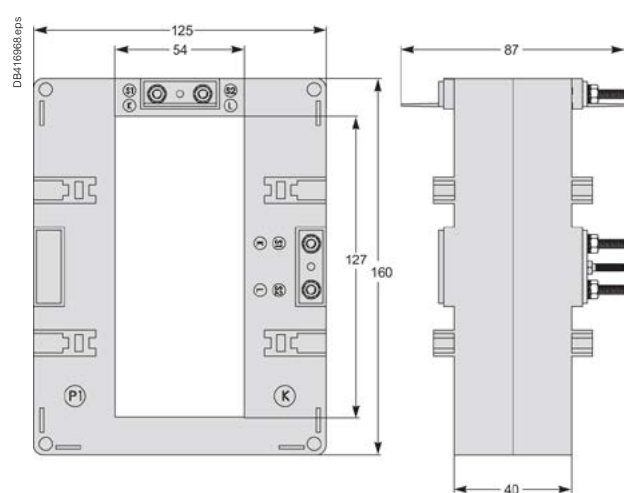

See appropriate Installation Guide for these products.

DD internal profile type

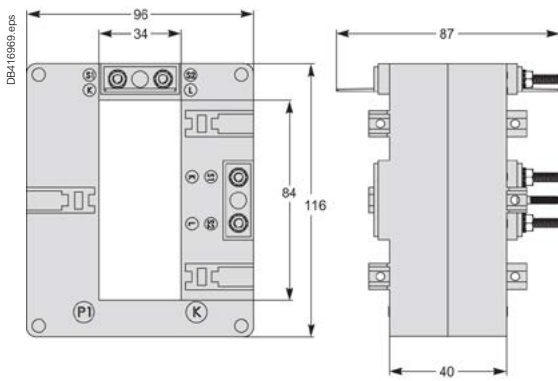

DE internal profile type

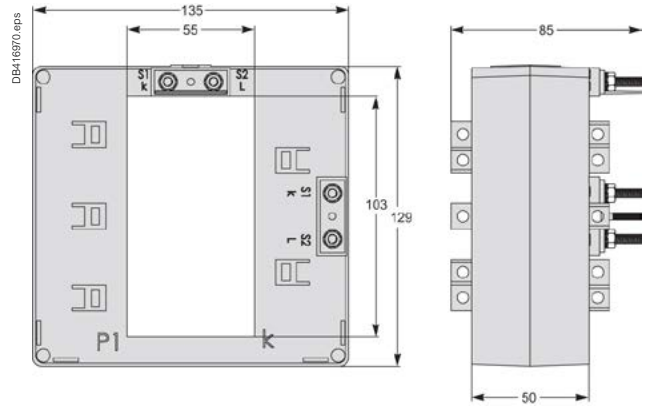

DH internal profile type

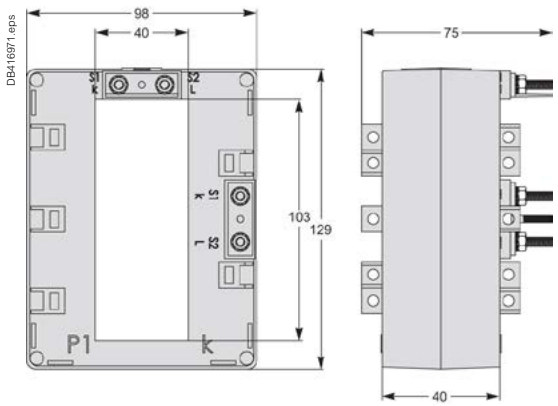

VV internal profile type

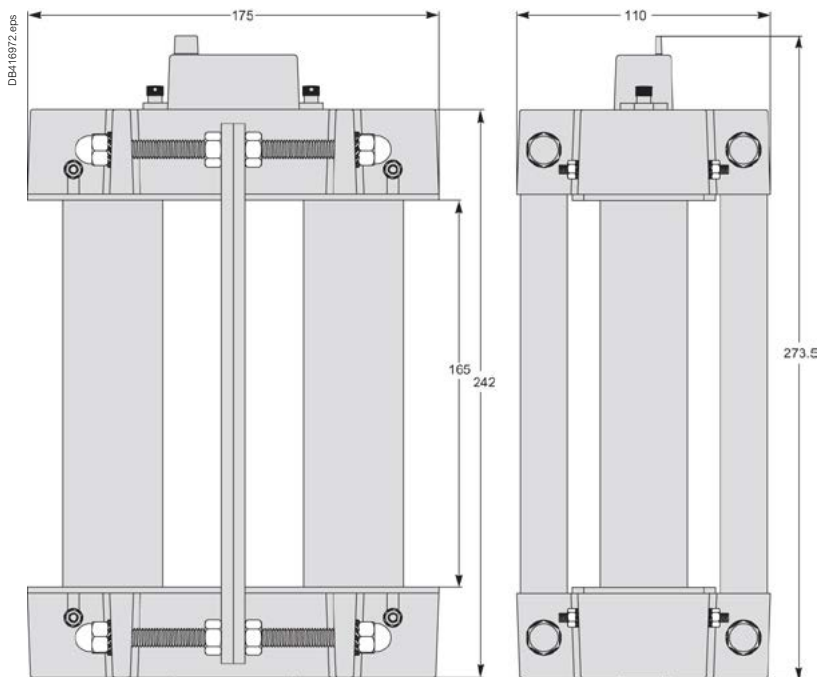

See appropriate Installation Guide for these products.

Cylinders dimensions

Cylinders

METSECT5CYL1

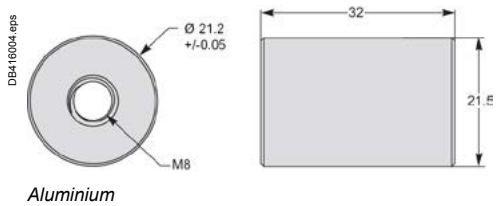

METSECT5CYL2

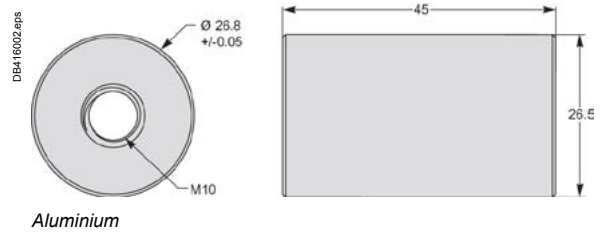

16550

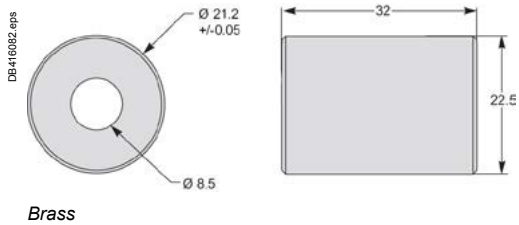

16551

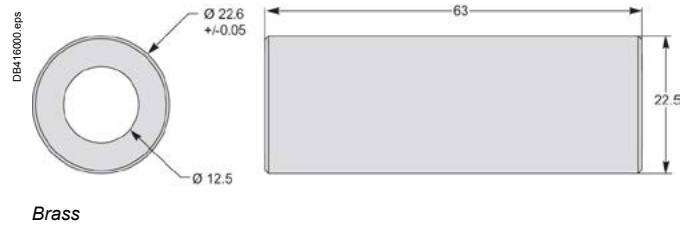

Covers

METSECT5COVER

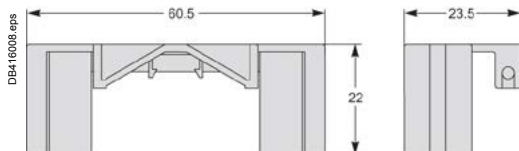

See appropriate Installation Guide for these products.



Commercial reference numbers

Commercial reference numbers

Commercial ref. no.	Description	Page	Commercial ref. no.	Description	Page
	Current Transformers	143		Basic Energy Metering	14
	CT Ip/5 A ratio	146		iEM2000	16
METSECT5CC004	CC 40 A		A9MEM2000T	iEM2000T basic energy meter, no display	
METSECT5CC005	CC 50 A		A9MEM2000	iEM2000 basic energy meter	
METSECT5CC006	CC 60 A		A9MEM2010	iEM2010 energy meter, kWh pulse output	
METSECT5CC008	CC 75 A		A9MEM2100	iEM2100 basic energy meter	
METSECT5CC010	CC 100 A		A9MEM2050	iEM2050 modular single phase power meter 230 V - 45 A with Modbus	
METSECT5CC013	CC 125 A		A9MEM2055	iEM2055 modular single phase power meter 230 V - 45 A with Modbus, MID	
METSECT5CC015	CC 150 A		A9MEM2105	iEM2105 energy meter, kWh pulse output with partial meter	
METSECT5CC020	CC 200 A		A9MEM2110	iEM2110 energy meter, kWh and kvarh pulse outputs with two tariffs, four quadrant energy measurement, MID certified	
METSECT5CC025	CC 250 A		A9MEM2135	iEM2135 energy meter, M-Bus communication, four quadrant energy measurement, two tariffs, MID certified	
METSECT5MB025	MB 250 A		A9MEM2150	iEM2150 energy meter, Modbus communication, four quadrant energy measurement	
METSECT5MB030	MB 300 A		A9MEM2155	iEM2155 energy meter, Modbus communication, four quadrant energy measurement, two tariffs, MID certified	
METSECT5MB040	MB 400 A			iEM3000	23
METSECT5MA015	MA 150 A		A9MEM3200	iEM3200 basic energy meter	
METSECT5MA020	MA 200 A		A9MEM3210	iEM3210 energy meter with pulse output	
METSECT5MA025	MA 250 A		A9MEM3215	iEM3215 multi-tariff energy meter	
METSECT5MA030	MA 300 A		A9MEM3235	iEM3235 advanced multi-tariff energy meter & electrical parameter plus M-Bus comm port	
METSECT5MA040	MA 400 A		A9MEM3250	iEM3250 energy meter & electrical parameter plus Modbus RS-485 comm port	
METSECT5MC025	MC 250 A		A9MEM3255	iEM3255 advanced multi-tariff energy meter & electrical parameter plus Modbus RS485 comm port	
METSECT5MC030	MC 300 A		A9MEM3265	iEM3265 advanced multi-tariff energy meter & electrical parameter plus BACnet MS/TP comm port	
METSECT5MC040	MC 400 A		A9MEM3275	iEM3275 advanced multi-tariff energy meter & electrical parameter plus LON TP/FT-10 comm port	
METSECT5MC050	MC 500 A		A9MEM3300	iEM3300 basic energy meter	
METSECT5MC060	MC 600 A		A9MEM3310	iEM3310 energy meter with pulse output	
METSECT5MC080	MC 800 A		A9MEM3335	iEM3335 advanced multi-tariff energy meter & electrical parameter plus M-Bus comm port	
METSECT5MD050	MD 500 A		A9MEM3350	iEM3350 energy meter & electrical parameter plus Modbus RS-485 comm port	
METSECT5MD060	MD 600 A		A9MEM3355	iEM3355 advanced multi-tariff energy meter & electrical parameter plus Modbus RS485 comm port	
METSECT5MD080	MD 800 A			Basic Multi-Function Metering	30
METSECT5CYL1	Cylinder 8.5 mm dia.			PM3000	32
METSECT5CYL2	Cylinder 10.5 mm dia.		METSEPM3200	PM3200 basic power meter	
METSECT5COVER	sealable cover 60.5 x 22 x 23.5 mm for CT TI		METSEPM3210	PM3210 power meter with pulse output	
METSECT5VV500	CT tropicalised 5000 5 bars 55x165		METSEPM3250	PM3250 power meter with RS485 port	
METSECT5VV600	CT tropicalised 6000 5 bars 55x165		METSEPM3255	PM3255 power meter plus 2 digital inputs, 2 digital outputs with RS-485 port	
METSECT5DA040	CT tropicalised 400 5 dual out. bars 32x65			PM5000	38
METSECT5DA050	CT tropicalised 500 5 dual out. bars 32x65		METSEPM5100	Power Meter range 72 mm depth, control power to 415 V AC, CI 0.5S, 15th harmonic, no communication, 1DO	
METSECT5DA060	CT tropicalised 600 5 dual out. bars 32x65		METSEPM5110	Power Meter range 72 mm depth, control power to 415 V AC, CI 0.5S, 15th harmonic, RS-485 Modbus, 1DO	
METSECT5DA080	CT tropicalised 800 5 dual out. bars 32x65		METSEPM5111	Power Meter range 72 mm depth, control power to 415 V AC, CI 0.5S, 15th harmonic, RS-485 Modbus, 1DO, MID cert	
METSECT5DA100	CT tropicalised 1000 5 dual out. bars 32x65				
METSECT5DA125	CT tropicalised 1250 5 dual out. bars 32x65				
METSECT5DA150	CT tropicalised 1500 5 dual out. bars 32x65				
METSECT5DB100	CT tropicalised 1000 5 dual out. bars 38x127				
METSECT5DB125	CT tropicalised 1250 5 dual out. bars 38x127				
METSECT5DB150	CT tropicalised 1500 5 dual out. bars 38x127				
METSECT5DB200	CT tropicalised 2000 5 dual out. bars 38x127				
METSECT5DB250	CT tropicalised 2500 5 dual out. bars 38x127				
METSECT5DB300	CT tropicalised 3000 5 dual out. bars 38x127				
METSECT5DC200	CT tropicalised 2000 5 dual out. bars 52x127				
METSECT5DC250	CT tropicalised 2500 5 dual out. bars 52x127				
METSECT5DC300	CT tropicalised 3000 5 dual out. bars 52x127				
METSECT5DC400	CT tropicalised 4000 5 dual out. bars 52x127				
METSECT5DD100	CT tropicalised 1000 5 dual out. bars 34x84				
METSECT5DD125	CT tropicalised 1250 5 dual out. bars 34x84				
METSECT5DD150	CT tropicalised 1500 5 dual out. bars 34x84				
METSECT5DE100	CT tropicalised 1000 5 dual out. bars 54x102				
METSECT5DE125	CT tropicalised 1250 5 dual out. bars 54x102				
METSECT5DE150	CT tropicalised 1500 5 dual out. bars 54x102				
METSECT5DE200	CT tropicalised 2000 5 dual out. bars 54x102				
METSECT5DH125	CT tropicalised 1250 5 dual out. bars 38x102				
METSECT5DH150	CT tropicalised 1500 5 dual out. bars 38x102				
METSECT5DH200	CT tropicalised 2000 5 dual out. bars 38x102				

Commercial ref. no.	Description	Page	Commercial ref. no.	Description	Page
METSEPM5310	Power Meter range 72 mm depth, control power to 415 V AC, CI 0.5S, 31st harmonic, 256 kB, RS-485 Modbus, 2DI/2DO		METSE7x4MAK	ION7x50 Mounting Adapter Kit	
METSEPM5310R	Power Meter range 72 mm depth, control power to 415 V AC, CI 0.5S, 31st harmonic, 256 kB, RJ45 LVCT, RS-485 Modbus, 2DI/2DO			Multi-Circuit Metering	84
METSEPM5320	Power Meter range 72 mm depth, control power to 415 V AC, CI 0.5S, 31st harmonic, 256 kB, Ethernet, 2DI/2DO			BCPM (Branch Circuit Power Meter)	86
METSEPM5320R	Power Meter range 72 mm depth, control power to 415 V AC, CI 0.5S, 31st harmonic, 256 kB, RJ45 LVCT, Ethernet, 2DI/2DO		BCPMA084S	84-circuit solid-core power & energy meter, 100A CTs (4 strips), 19.05 mm spacing	
METSEPM5330	Power Meter range 72 mm depth, control power to 415 V AC, CI 0.5S, 31st harmonic, 256 kB, RS-485 Modbus, 2DI/2DO, 2Relay		BCPMA184S	84-circuit solid-core power & energy meter, 100A CTs (4 strips), 25.4 mm spacing	
METSEPM5331	Power Meter range 72 mm depth, control power to 415 V AC, CI 0.5S, 31st harmonic, 256 kB, RS-485 Modbus, 2DI/2DO, 2Relay, MID cert		BCPMA042S	42-circuit solid-core power & energy meter, 100A CTs (2 strips), 19.05 mm spacing	
METSEPM5340	Power Meter range 72 mm depth, control power to 415 V AC, CI 0.5S, 31st harmonic, 256 kB, Ethernet, 2DI/2DO, 2Relay		BCPMA142S	42-circuit solid-core power & energy meter, 100A CTs (2 strips), 25.4 mm spacing	
METSEPM5341	Power Meter range 72 mm depth, control power to 415 V AC, CI 0.5S, 31st harmonic, 256 kB, Ethernet, 2DI/2DO, 2Relay, MID cert		BCPMA224S	24-circuit solid-core power & energy meter, 100A CTs (2 strips), 18 mm spacing	
METSEPM5560	Power Meter range 77 mm depth, control power to 480 V AC, CI 0.2S, 63rd harmonic, 1.1 MB, Modbus and Ethernet, 4DI/2DO		BCPMA236S	36-circuit solid-core power & energy meter, 100A CTs (2 strips), 18 mm spacing	
METSEPM5561	Power Meter range 77 mm depth, control power to 480 V AC, CI 0.2S, 63rd harmonic, 1.1 MB, Modbus and Ethernet, MID cert		BCPMA242S	42-circuit solid-iEM2000core power & energy meter, 100 A CTs (2 strips), 18 mm spacing	
METSEPM5563*	Power Meter range 77 mm depth, control power to 480 V AC, CI 0.2S, 63rd harmonic, 1.1 MB, DIN mount, no display, 4DI/2DO		BCPMA248S	48-circuit solid-core power & energy meter, 100 A CTs (4 strips), 18 mm spacing	
METSEPM5563RD*	PM5500 power meter, ETH-serial + 4DI-2DO out, remote display		BCPMA272S	72-circuit solid-core power & energy meter, 100 A CTs (4 strips), 18 mm spacing	
METSEPM5RD*	Remote display for PM5563 power meter		BCPMA284S	84-circuit solid-core power & energy meter, 100 A CTs (4 strips), 18 mm spacing	
*METSEPM5563RD includes both METSEPM5563 and METSEPM5RD			BCPMB084S	84-circuit solid-core branch current, mains power meter, 100 A CTs (4 strips), 19.05 mm spacing	
METSEPM51HK	Hardware kit for PM51XX (voltage, current, comms & IO connectors + moulding clips)		BCPMB184S	84-circuit solid-core branch current, mains power meter, 100 A CTs (4 strips), 25.4 mm spacing	
METSEPM53HK	Hardware kit for PM53XX (voltage, current, comms & IO connectors + moulding clips)		BCPMB042S	42-circuit solid-core branch current, mains power meter, 100 A CTs (2 strips), 19.05 mm spacing	
METSEPM55HK	Hardware kit for PM55XX (voltage, current, comms & IO connectors + moulding clips)		BCPMB142S	42-circuit solid-core branch current, mains power meter, 100 A CTs (2 strips), 25.4 mm spacing	
METSEPM55RSK	Revenue sealing kit for PM55XX (sealing covers for voltage & current connectors)		BCPMB224S	24-circuit solid-core branch current, mains power meter, 100 A CTs (2 strips), 18 mm spacing	
	Advanced Metering	48	BCPMB236S	36-circuit solid-core branch current, mains power meter, 100 A CTs (2 strips), 18 mm spacing	
	PM8000	50	BCPMB242S	42-circuit solid-core branch current, mains power meter, 100 A CTs (2 strips), 18 mm spacing	
METSEPM8240	DIN96 panel mount meter		BCPMB248S	48-circuit solid-core branch current, mains power meter, 100 A CTs (4 strips), 18 mm spacing	
METSEPM8243	DIN rail mount meter		BCPMB272S	72-circuit solid-core branch current, mains power meter, 100 A CTs (4 strips), 18 mm spacing	
METSEPM8244	DIN rail mount meter with remote display		BCPMB284S	84-circuit solid-core branch current, mains power meter, 100 A CTs (4 strips), 18 mm spacing	
METSEPM89RD96	Remote display, 3 metre cable, mounting hardware for 30mm hole (nut & centering pin), mounting hardware for DIN96 cutout (92x92mm) adapter plate		BCPMC084S	84-circuit solid-core branch current meter, 100 A CTs (4 strips), 19.05 mm spacing	
METSEPM8000SK	Terminal covers for utility sealing		BCPMC184S	84-circuit solid-core branch current meter, 100 A CTs (4 strips), 25.4 mm spacing	
METSEPM8HWK	PM8000 hardware kit		BCPMC042S	42-circuit solid-core branch current meter, 100 A CTs (2 strips), 19.05 mm spacing	
METSEPM89M2600	Digital I/O module (6 digital inputs & 2 relay outputs)		BCPMC142S	42-circuit solid-core branch current meter, 100 A CTs (2 strips), 25.4 mm spacing	
METSEPM89M0024	Analog I/O module (4 analog inputs & 2 analog outputs)		BCPMC224S	24-circuit solid-core branch current meter, 100 A CTs (2 strips), 18 mm spacing	
	ION9000	60	BCPMC236S	36-circuit solid-core branch current meter, 100 A CTs (2 strips), 18 mm spacing	
METSEION92030	ION9200 meter, DIN mount, no display, HW kit		BCPMC242S	42-circuit solid-core branch current meter, 100 A CTs (2 strips), 18 mm spacing	
METSEION92040	ION9200 meter, DIN mount, 192 mm display, B2B adapter, HW kit		BCPMC248S	48-circuit solid-core branch current meter, 100 A CTs (4 strips), 18 mm spacing	
METSEPM89RD96	Remote display, color LCD, 96 x 96 mm		BCPMC272S	72-circuit solid-core branch current meter, 100 A CTs (4 strips), 18 mm spacing	
METSERD192	Remote display, color touchscreen, 192 x 192 mm		BCPMC284S	84-circuit solid-core branch current meter, 100 A CTs (4 strips), 18 mm spacing	
METSEPM89M2600	I/O module, 2 relay outputs, 6 digital inputs		BCPME042S	42-circuit solid-core power & energy meter w/Ethernet, 100 A CTs (2 strips), 19.05 mm spacing	
METSEPM89M0024	I/O module, 2 analog outputs, 4 analog inputs				
METSE9HWK	ION9000 meter hardware kit – plugs, terminal guards, spare grounding screw, DIN clips				
METSERD192HWK	RD192 remote display hardware kit				
METSE9B2BMA	ION9000 B2B adapter				
METSE9CTHWK	ION9000 Current Input hardware kit – terminal screws, CT covers				

Commercial ref. no.	Description	Page	Commercial ref. no.	Description	Page
BCPME084S	84-circuit solid-core power & energy meter w/Ethernet, 100 A CTs (4 strips), 19.05 mm spacing		BCPMSCE42S	42-circuit split-core power and energy meter w/Ethernet, (42) 50 A CTs & (2) 1.21 m cables	
BCPME142S	42-circuit solid-core power & energy meter w/Ethernet, 100 A CTs (2 strips), 25.4 mm spacing		BCPMSCE60S	60-circuit split-core power and energy meter w/Ethernet, (60) 50 A CTs & (4) 1.21 m cables	
BCPME184S	84-circuit solid-core power & energy meter w/Ethernet, 100 A CTs (4 strips), 25.4 mm spacing		BCPMSCE84S	84-circuit split-core power and energy meter w/Ethernet, (84) 50 A CTs & (4) 1.21 m cables	
BCPME224S	24-circuit solid-core power & energy meter w/Ethernet, 100 A CTs (2 strips), 18 mm spacing		BCPMSCADPBS	BCPM adapter boards, quantity 2, for split core BCPM	
BCPME236S	36-circuit solid-core power & energy meter w/Ethernet, 100 A CTs (2 strips), 18 mm spacing		BCPMSCCT0	BCPM 50 A split core CTs, Quantity 6, 1.8 m lead lengths	
BCPME242S	42-circuit solid-core power & energy meter w/Ethernet, 100 A CTs (2 strips), 18 mm spacing		BCPMSCCT0R20	BCPM 50 A split core CTs, quantity 6, 6 m lead lengths	
BCPME248S	48-circuit solid-core power & energy meter w/Ethernet, 100 A CTs (4 strips), 18 mm spacing		BCPMSCCT1	BCPM 100 A split core CTs, Quantity 6, 1.8 m lead lengths	
BCPME272S	72-circuit solid-core power & energy meter w/Ethernet, 100 A CTs (4 strips), 18 mm spacing		BCPMSCCT1R20	BCPM 100 A split core CTs, Quantity 6, 6 m lead lengths	
BCPME284S	84-circuit solid-core power & energy meter w/Ethernet, 100 A CTs (4 strips), 18 mm spacing		BCPMSCCT3	BCPM 200 A split core CTs, Quantity 1, 1.8 m lead lengths	
BCPMSCA1S	42-circuit split-core power and energy meter, CTs and cables sold separately		BCPMSCCT3R20	BCPM 200 A split core CTs, Quantity 1, 6 m lead lengths	
BCPMSCA2S	84-circuit split-core power and energy meter, CTs and cables sold separately		BCPMCOVERS	BCPM circuit board cover	
BCPMSCA30S	30-circuit split-core power and energy meter, (30) 50 A CTs & (2) 1.21 m cables		BCPMREPAIR	CT repair kit for solid core BCPM (includes one CT)	
BCPMSCA42S	42-circuit split-core power and energy meter, (42) 50 A CTs & (2) 1.21 m cables		H6803R-0100	H6803R-0100 Additional 100A split core CT for use with solid core repair kit	
BCPMSCA60S	60-circuit split-core power and energy meter, (60) 50 A CTs & (4) 1.21 m cables		E8951	Modbus to BACnet protocol converter	
BCPMSCA84S	84-circuit split-core power and energy meter, with (84) 50 A CTs & (4) 1.21 m cables		CBL008	Flat Ribbon cable for BCPM, length = 0.45 m	
BCPMSCB1S	42-circuit split-core branch current, mains power meter, CTs and cables sold separately		CBL016	Flat Ribbon cable for BCPM, length = 1.2 m	
BCPMSCB2S	84-circuit split-core branch current, mains power meter, CTs and cables sold separately		CBL017	Flat Ribbon cable for BCPM, length = 1.5 m	
BCPMSCB30S	30-circuit split-core branch current, mains power meter, (30) 50 A CTs & (2) 1.21 m cables		CBL018	Flat Ribbon cable for BCPM, length = 1.8 m	
BCPMSCB42S	42-circuit split-core branch current, mains power meter, (42) 50 A CTs & (2) 1.21 m cables		CBL019	Flat Ribbon cable for BCPM, length = 2.4 m	
BCPMSCB60S	60-circuit split-core branch current, mains power meter, (60) 50 A CTs & (4) 1.21 m cables		CBL020	Flat Ribbon cable for BCPM, length = 3.0 m	
BCPMSCBY63S	42-circuit split-core branch current, mains, all boards on backplate, CTs and cables sold separately		CBL021	Flat Ribbon cable for BCPM, length = 6.1 m	
BCPMSCB84S	84-circuit split-core branch current, mains power meter, (84) 50 A CTs & (4) 1.21 m cables		CBL022	Round Ribbon cable for BCPM, length = 1.2 m	
BCPMSCC1S	42-circuit split-core current meter, CTs and cables sold separately		CBL023	Round Ribbon cable for BCPM, length = 3 m	
BCPMSCC2S	84-circuit split-core current meter, CTs and cables sold separately		CBL024	Round Ribbon cable for BCPM, length = 6.1 m	
BCPMSCC30S	30-circuit split-core current meter, (30) 50 A CTs & (2) 1.21 m cables		CBL031	Round Ribbon cable for BCPM, length = 0.5 m	
BCPMSCC42S	42 circuit split-core current meter, (42) 50 A CTs & (2) 1.21 m cables		CBL033	Round Ribbon cable for BCPM, length = 0.8 m	
BCPMSCC60S	60-circuit split-core current meter, (60) 50 A CTs & (4) 1.21 m cables		LVCT00050S	50 A 10 mm x 11 mm	
BCPMSCCY63S	42-circuit split-core current meter, all boards on backplate, CTs and cables sold separately		LVCT00101S	100 A 16 mm x 20 mm	
BCPMSCC84S	84-circuit split-core current meter, (84) 50 A CTs & (4) 1.21 m cables		LVCT00102S	100 A 30 mm x 31 mm	
BCPMSCE1S	42-circuit split-core power and energy meter w/Ethernet, CTs and cables sold separately		LVCT00202S	200 A 30 mm x 31 mm	
BCPMSCE2S	84-circuit split-core power and energy meter w/Ethernet, CTs and cables sold separately		LVCT00302S	300 A 30 mm x 31 mm	
BCPMSCE30S	30-circuit split-core power and energy meter w/Ethernet, (30) 50A CTs & (2) 1.21 m cables		LVCT00403S	400 A 62 mm x 73 mm	
			LVCT00603S	600 A 62 mm x 73 mm	
			LVCT00803S	800 A 62 mm x 73 mm	
			LVCT00804S	800 A 62 mm x 139 mm	
			LVCT01004S	1000 A 62 mm x 139 mm	
			LVCT01204S	1200 A 62 mm x 139 mm	
			LVCT01604S	1600 A 62 mm x 139 mm	
			LVCT02004S	2000 A 62 mm x 139 mm	
			LVCT02404S	2400 A 62 mm x 139 mm	
			LVCT20050S	50 A 10 mm	
			LVCT20100S	100 A 10 mm	
			LVCT20202S	200 A 25 mm	
				Communications & Gateways	100
				Link150 Ethernet gateway	105
			EGX150	Link150 Ethernet gateway	
				Com'X 200/210/510	109
			EBX210	Com'X 210 data logger 24 V DC power supplied UL rated	
			EBX510	Com'X 510 energy server 24 V DC power supplied UL rated	
			EBXA-GPRS-SIM	Com'X GPRS interface SIM card	
			EBXA-ANT-5M	Com'X External GPRS antenna	

Commercial ref. no.	Description	Page	Commercial ref. no.	Description	Page
EBXA-USB-Zigbee	Com'X Zigbee USB interface		PSA105100	PowerSCADA Anywhere, 5 User Pack	
	ION7550 RTU	119	PSA104112	Advanced Reporting and Dashboards Module	
M7550A0N9B9A0A0A	7550-I/5M/512S-RTU-P240-SCOM PML 7550 PO		PSA104113	Event Notification Module	
M7550A0N9B9E0A0A	SE-7550-I/5M/512S-RTU-P240-ETH PML 7550		PSA104114	Billing Module	
M7550A0N9B9E0E0A	SE-7550-I/5M/512S-RTU-P240-ETH-20MAI PML		PSA104115	Breaker Performance Module	
	Power Monitoring Software	128	PSA104116	Energy Analysis Module	
	EcoStruxure™ Power Monitoring Expert	130	PSA104121	Power Capacity Module	
	Server & Options		PSA104124	Power Quality Advisor Module	
PSWSANCZZSPEZZ	PME Standard Edition BASE licence (includes 1 Engineering Client)		PSA104125	Insulation Monitoring Module	
PSWSYNCZZSPEZZ	PME Starter Edition		PSA104126	Backup Power Module	
PSWSONCZZSPEZZ	OPC DA Server for PME software		Please see your Schneider Electric Representative for complete ordering information.		
PSWMVNCZZSPEZZ	Event Notification module for PME software				
PSWSQL2017L	SQL Server 2017 software 2-CORE license				
PSWMCFAFEWL	McAfee Whitelisting (Embedded Control)				
PSWSSNCZZNPEZZ	PME Secondary Server				
	Client Licences (System users)				
PSWCENCZZNPEZZ	"Engineering Client for Power Monitoring Expert software"				
PSWCWNCZZNPEZZ	Web Client for PME software				
PSWCZNCZZSPEZZ	"Unlimited Engineering and Web Clients for PME software"				
	Device Licences (Connected devices)				
PSWDENCZZNPEZZ	Entry-Range Device for PME software				
PSWDMNCZZNPEZZ	Mid-Range Device for PME software				
PSWDSNCZZNPEZZ	High-End Device for PME software				
PSWDZNCZZSPEZZ	Unlimited Devices for PME software				
	Optional Software Modules				
PSWMANCZZSPEZZ	Backup Power Module				
PSWMXNCZZSPEZZ	Breaker Performance Module				
PSWMPNCZZSPEZZ	Capacity Management Module				
PSWGENCZZSPEZZ	Energy Analysis Dashboard Module				
PSWMZNCZZSPEZZ	Energy Analysis Reports Module				
PSWMBNCZZSPEZZ	Energy Billing Module				
PSWMHNCZZSPEZZ	Insulation Monitoring Module				
PSWPQACZZSPEZZ	Power Quality Performance Module				
	Power Advisor and Software Assurance Credits				
PSWPAPRIME	Power Advisor PRIME				
PSWPAULTRA	Power Advisor ULTRA				
PSWSA1YR	Software Assurance 1 year				
PSWSA3YR	Software Assurance 3 years				
	EcoStruxure™ Power SCADA Operation				
PSA109922	PowerSCADA DVD and USB key				
PSA109921	PowerSCADA Additional USB Key				
PSA109924	PowerSCADA Software Key				
PSA101113	PowerSCADA Server, 1500 Points				
PSA101114	PowerSCADA Server, 5000 Points				
PSA101115	PowerSCADA Server, 15000 Points				
PSA101199	PowerSCADA Server, Unlimited Points				
PSA102013	PowerSCADA Control Client, 1500 Points				
PSA102014	PowerSCADA Control Client, 5000 Points				
PSA102015	PowerSCADA Control Client, 15000 Points				
PSA102099	PowerSCADA Control Client, Unlimited Points				
PSA103099	PowerSCADA View-only Client, Unlimited Points				

At Schneider, we believe **access to energy and digital** is a basic human right. We empower all to **make the most of their energy and resources**, ensuring **Life Is On** everywhere, for everyone, at every moment.

We provide **energy and automation digital** solutions for **efficiency and sustainability**. We combine world-leading energy technologies, real-time automation, software and services into integrated solutions for Homes, Buildings, Data Centers, Infrastructure and Industries.

We are committed to unleash the infinite possibilities of an **open, global, innovative community** that is passionate about our **Meaningful Purpose, Inclusive and Empowered** values.

www.se.com

Schneider Electric

United Kingdom
Stafford Park 5,
Telford
Shropshire
TF3 3BL
Tel: 0870 608 8 608
Fax: 0870 608 8 606

www.se.com/uk

Ireland
Head office, Block A
Maynooth Business Campus
Maynooth, Co. Kildare
W23 Y7X0
Tel: 1 800 805 800
Fax: (01) 601 2201

www.se.com/ie

