



SIRIUS safety relay Basic unit Standard series Relay enabling circuits 3 NO contacts plus Relay signaling circuit 1 NC contact $U_s = 24 \text{ V AC/DC}$ Spring-type terminal (push-in)

product brand name	SIRIUS
product category	Safety relays
product designation	safety relays
design of the product	Relay enabling circuits
General technical data	
protection class IP of the enclosure	IP20
touch protection against electrical shock	finger-safe
insulation voltage rated value	300 V
ambient temperature	
• during storage	-40 ... +80 °C
• during operation	-25 ... +60 °C
air pressure according to SN 31205	900 ... 1 060 kPa
relative humidity during operation	10 ... 95 %
installation altitude at height above sea level maximum	4 000 m
vibration resistance according to IEC 60068-2-6	5 ... 500 Hz: 0.75 mm
shock resistance	10g / 11 ms
surge voltage resistance rated value	4 000 V
EMC emitted interference	IEC 60947-5-1, IEC 61000
installation environment regarding EMC	This product is suitable for Class B environments and can also be used in domestic environments.
overvoltage category	3
degree of pollution	3
reference code according to IEC 81346-2	F
power loss [W] maximum	2 W
number of sensor inputs 1-channel or 2-channel	1
design of the cascading	none
type of the safety-related wiring of the inputs	single-channel and two-channel
product feature cross-circuit-proof	Yes
Safety Integrity Level (SIL)	
• according to IEC 62061	3
• according to IEC 61508	3
performance level (PL)	
• according to ISO 13849-1	e
category according to EN ISO 13849-1	4
Safe failure fraction (SFF)	99 %
PFHD with high demand rate according to EN 62061	1.7E-9 1/h
PFDAvg with low demand rate according to IEC 61508	0
T1 value for proof test interval or service life according to IEC 61508	20 y

hardware fault tolerance according to IEC 61508	1
safety device type according to IEC 61508-2	Type A
Inputs/ Outputs	
number of outputs as contact-affected switching element	
<ul style="list-style-type: none"> ● as NC contact <ul style="list-style-type: none"> — for signaling function instantaneous contact 	1
<ul style="list-style-type: none"> ● as NO contact <ul style="list-style-type: none"> — safety-related instantaneous contact — safety-related delayed switching 	3 0
stop category according to EN 60204-1	0
design of input	
<ul style="list-style-type: none"> ● cascading input/functional switching ● feedback input ● start input 	No Yes Yes
type of electrical connection plug-in socket	No
operating frequency maximum	360 1/h
switching capacity current	
<ul style="list-style-type: none"> ● of the NO contacts of the relay outputs <ul style="list-style-type: none"> — at DC-13 <ul style="list-style-type: none"> — at 24 V — at 115 V — at 230 V — at AC-15 <ul style="list-style-type: none"> — at 115 V — at 230 V ● of the NC contacts of the relay outputs <ul style="list-style-type: none"> — at DC-13 <ul style="list-style-type: none"> — at 24 V — at 115 V — at 230 V — at AC-15 <ul style="list-style-type: none"> — at 115 V — at 230 V 	5 A 0.2 A 0.1 A 5 A 5 A 1 A 0.2 A 0.1 A 1.5 A 1.5 A
thermal current of the switching element with contacts maximum	5 A
total current maximum	12 A
operational current at 17 V minimum	5 mA
mechanical service life (switching cycles) typical	10 000 000
design of the fuse link for short-circuit protection of the NO contacts of the relay outputs required	gL/gG: 6A or circuit breaker type A: 3A or circuit breaker type B: 2A or circuit breaker type C: 1A
design of the fuse link for short circuit protection of the NC contacts of the relay outputs required	Diazed or Neoazed fuses, operating class gL/gG: 6 A or MCB type A: 2 A or MCB type B: 2 A or MCB type C: 1 A
wire length	
<ul style="list-style-type: none"> ● for total of all sensor circuits with Cu 1.5 mm² and 150 nF/km maximum 	2 000 m
make time with automatic start	
<ul style="list-style-type: none"> ● typical ● at DC maximum ● at AC maximum 	200 ms 320 ms 320 ms
make time with automatic start after power failure	
<ul style="list-style-type: none"> ● typical ● maximum 	200 ms 320 ms
make time with monitored start	
<ul style="list-style-type: none"> ● maximum ● typical 	20 ms 15 ms
backslide delay time after opening of the safety circuits typical	10 ms
backslide delay time in the event of power failure	
<ul style="list-style-type: none"> ● typical ● maximum 	65 ms 75 ms

recovery time after opening of the safety circuits typical	10 ms
recovery time after power failure typical	0.09 s
pulse duration	
• of the sensor input minimum	150 ms
• of the ON pushbutton input minimum	0.015 s
Control circuit/ Control	
type of voltage of the control supply voltage	AC/DC
control supply voltage frequency	
• 1 rated value	50 Hz
• 2 rated value	60 Hz
control supply voltage	
• at DC	24 V
— rated value	
• at AC	24 V
— at 50 Hz	
— rated value	
— at 60 Hz	24 V
— rated value	
operating range factor control supply voltage rated value of magnet coil	
• at AC	0.85 ... 1.1
— at 50 Hz	
— at 60 Hz	0.85 ... 1.1
• at DC	0.85 ... 1.2
Installation/ mounting/ dimensions	
mounting position	any
required spacing for grounded parts at the side	5 mm
fastening method	screw and snap-on mounting
width	22.5 mm
height	100 mm
depth	121.6 mm
Connections/ Terminals	
type of electrical connection	spring-loaded terminal (push-in)
type of connectable conductor cross-sections	
• solid	1x (0.5 ... 1.5 mm ²), 2x (0.5 ... 1.5 mm ²)
• finely stranded	
— with core end processing	1x (0.5 ... 1.0 mm ²), 2x (0.5 ... 1.0 mm ²)
— without core end processing	1x (0.5 ... 1.5 mm ²), 2x (0.5 ... 1.5 mm ²)
type of connectable conductor cross-sections at AWG cables	
• solid	1x (20 ... 16), 2x (20 ... 16)
• stranded	1x (20 ... 16), 2x (20 ... 16)
Product Function	
product function parameterizable	sensor floating / sensor non-floating, monitored start-up / automatic start
suitability for operation device connector 3ZY12	No
suitability for interaction press control	No
suitability for use	
• safety switch	Yes
• monitoring of floating sensors	Yes
• monitoring of non-floating sensors	Yes
• magnetically operated switch monitoring	Yes
• safety-related circuits	Yes
Certificates/ approvals	
General Product Approval	EMC



[Confirmation](#)



Functional Safety/Safety of Machinery	Declaration of Conformity	Test Certificates	Marine / Shipping
---------------------------------------	---------------------------	-------------------	-------------------

[Type Examination Certificate](#)



[Type Test Certificates/Test Report](#)



Marine / Shipping	other	Railway
-------------------	-------	---------



[Confirmation](#)

[Confirmation](#)

Further information

Information- and Downloadcenter (Catalogs, Brochures,...)

<https://www.siemens.com/ic10>

Industry Mall (Online ordering system)

<https://mall.industry.siemens.com/mall/en/en/Catalog/product?mlfb=3SK1111-2AB30>

Cax online generator

<http://support.automation.siemens.com/WW/CAXorder/default.aspx?lang=en&mlfb=3SK1111-2AB30>

Service&Support (Manuals, Certificates, Characteristics, FAQs,...)

<https://support.industry.siemens.com/cs/ww/en/ps/3SK1111-2AB30>

Image database (product images, 2D dimension drawings, 3D models, device circuit diagrams, EPLAN macros, ...)

http://www.automation.siemens.com/bilddb/cax_de.aspx?mlfb=3SK1111-2AB30&lang=en

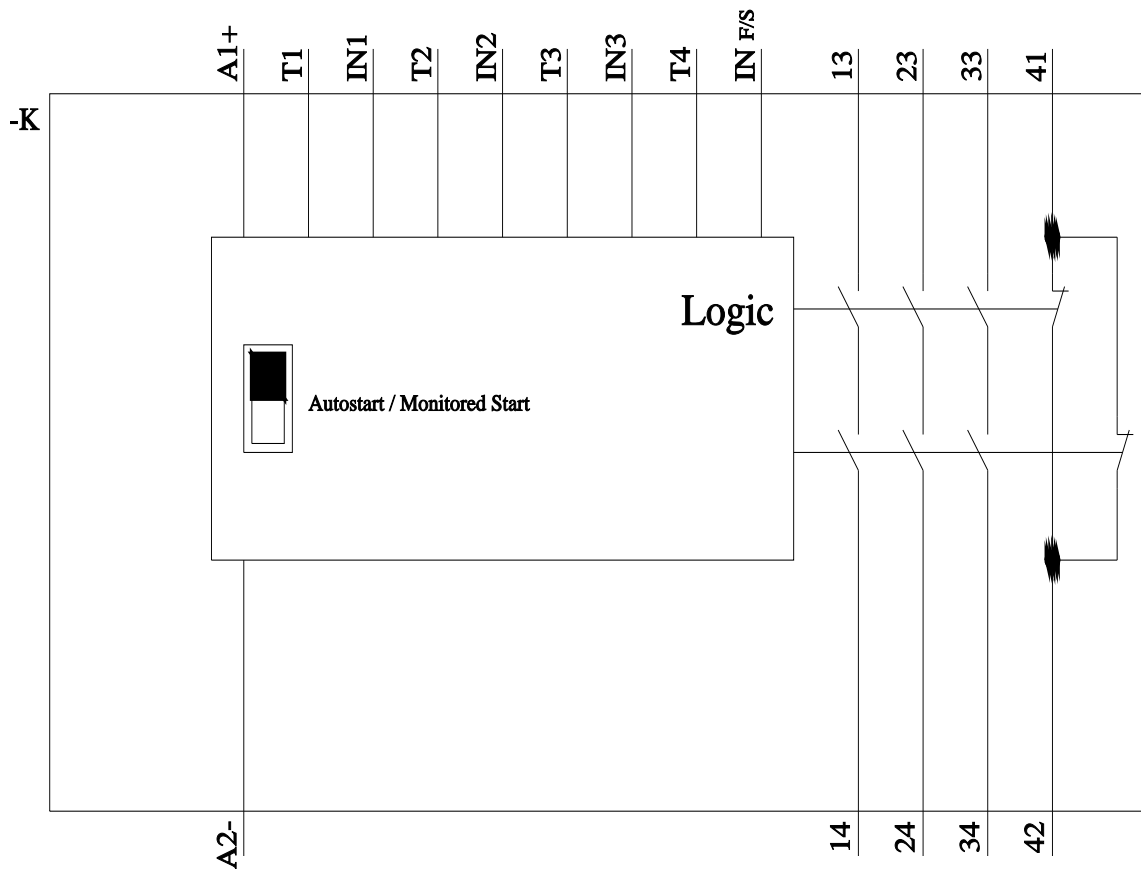

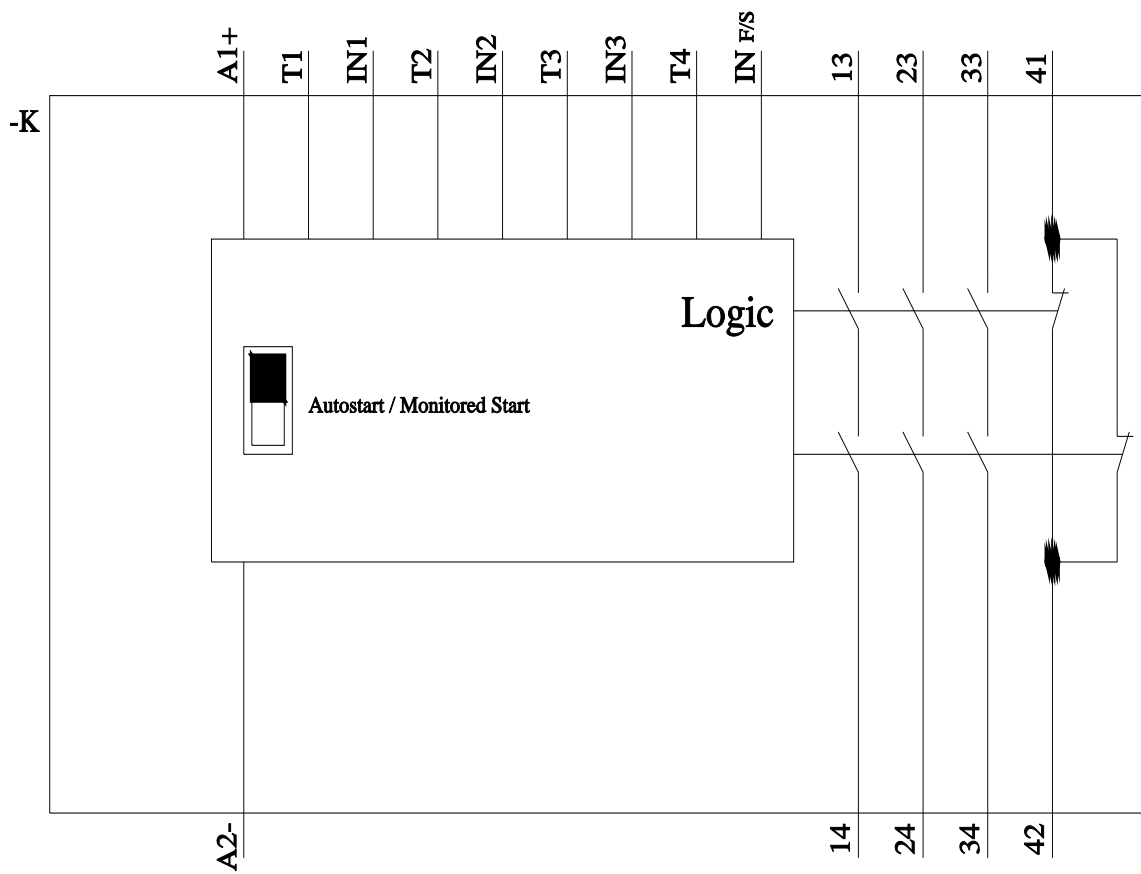

last modified:

6/15/2022 