

Newlec®

EMERGENCY SUSPENDED EXIT SIGN INSTRUCTIONS Issue 02 1st December 2016

THANK YOU for buying this product. To help ensure it gives complete satisfaction please install it according to these instructions and then pass the instructions to the appropriate person for retention and future reference.

SAFETY. This is a mains powered product. It is designed to be installed by suitably qualified personnel only and in accordance with the applicable building and electrical regulations. Before installation or maintenance the electrical supply to the product must be isolated.

WARRANTY This product is warranted to be free of defects in materials, design and workmanship for 5 years from the date of purchase. If a suspected fault should develop in this time, please call our helpline on +44 (0)800 783 6909. This warranty does not include batteries or consumable items such as fuses.

INSTALLATION SUPPORT If installation advice or accessories are required please also contact us on the number above. We will do our best to help. When reporting a suspected fault or seeking installation support the problem is likely to be resolved most quickly if you have full product details to-hand, as well as details of when and where it was purchased.

LUMINAIRE INSTALLATION

1. Remove the cover of surface mounting box by undoing the two screws. Undo the 3-pole connector to free up the fixing base plate c/w terminal block.
2. Prepare the fixing surface & provide a mains supply cable.
3. Pass the mains supply cable through the cable entry hole in the fixing base plate, offer the base plate up to the ceiling & secure. Ensure the fixing method is capable of holding the weight of the luminaire.
4. Route the mains supply cable to the terminal block & terminate, ensuring correct polarity is observed.
NOTE! THIS LUMINAIRE MUST BE EARTHED
NOTE! THIS LUMINAIRE NEEDS A PERMANENT LIVE SUPPLY
5. Offer the main luminaire up to the fixing base plate, reconnect the 3-pole connector, then fit the cover of the surface mounting box back on to the fixing base plate. Secure using the two screws.
6. Adjust the height of the chains as required.
7. Reconnect the power supply & check the green (batteries) & red (mains) LED charge indicators illuminate.
8. The batteries should be allowed to charge for at least 24 hours before carrying out a full discharge test to check they are charging correctly & the maintained duration is being achieved.

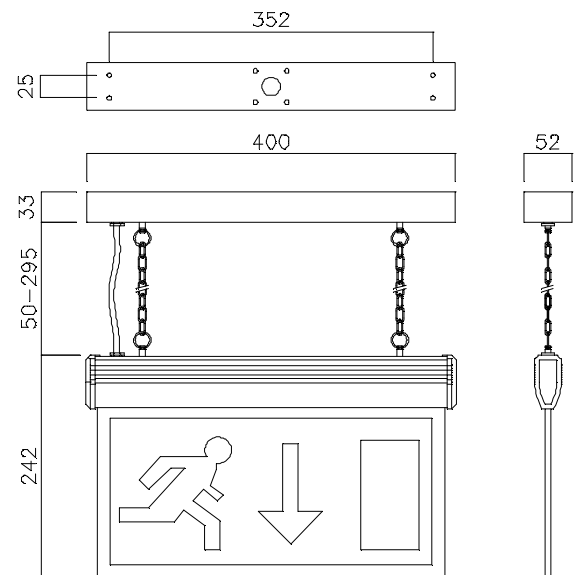

ALTERNATIVE LEGEND PANELS (OPTIONAL EXTRA)

This product comes as standard with the Euro Legend with the DOWN arrow. Alternative direction Euro legends & ISO 7010 format legends are also available.

To change:

1. Remove the end cap (without the LED indicators) from blade trim.
2. Slide the legend panel out.
3. Locate the pins on the new legend panel into the slot in the trim & slide along into position.
4. Replace the plastic end cap.

OPERATION / MAINTENANCE

1. Nominal battery life is 4 years, after which time they should be replaced with a suitable equivalent.
2. This luminaire **MUST** be disconnected before the circuit it is installed on is subjected to any high voltage or insulation resistance testing, otherwise irreparable damage will occur to luminaire components.
3. Ensure cleanliness of luminaires is maintained so as not to affect performance.

TESTING FOR EMERGENCY LUMINAIRES

Recommended routine test procedures in line with BS 5266 & BS EN 50172:

Monthly Functional Test

- Simulate a mains supply failure by isolating the circuit (ensuring if it is safe to do so) or by way of a test key switch if fitted into the circuit.
- Do this for a period of time sufficient to check that the light source illuminates from the battery supply.
- Once complete, ensure the normal supply is restored & that the green LED charge indicator illuminates.
- Log result/comments in the Testing Log Book (see page 2).

Annual Discharge Test

- Simulate a mains supply failure by isolating the circuit (ensuring if it is safe to do so) or by way of a test key switch if fitted into the circuit.
- This should be for the full 3-hour rated duration.
- Check that the light source illuminates & remains illuminated for the full rated duration period.
- Once complete, ensure the normal supply is restored & that the green LED charge indicator illuminates.
- Log result/comments in the Testing Log Book (see page 2).

TESTING LOG BOOK

Luminaire Type: Luminaire Location/No.:

MONTH	TEST	FIRST YEAR		SECOND YEAR		THIRD YEAR		FORTH YEAR		FIFTH YEAR	
		Signed	Date	Signed	Date	Signed	Date	Signed	Date	Signed	Date
1	FUNCTIONAL										
2	FUNCTIONAL										
3	FUNCTIONAL										
4	FUNCTIONAL										
5	FUNCTIONAL										
6	FUNCTIONAL										
7	FUNCTIONAL										
8	FUNCTIONAL										
9	FUNCTIONAL										
10	FUNCTIONAL										
11	FUNCTIONAL										
12	DISCHARGE										

Installed By: Installed Date:
 Contact Details:
