



Technical Hotline
+44 (0)1268 563720

Premier Technical

CABLE MANAGEMENT
PERIMETER AND
DISTRIBUTION

Integrated Trunking

TECHNICAL SPECIFICATION

MATERIALS

PVCu materials used in the manufacture of MK products are self extinguishing non-flame propagating in accordance with BS 4678: Part 4:1982.

Extrusion material has been tested by a UKAS accredited laboratory in accordance with the requirements of BS 476 Part 7 and has achieved a Class 1Y.

Moulding material has been tested by a UKAS accredited laboratory and conforms with IEC 695-2-1 at a severity of 650°C

IET WIRING REGULATIONS

Designed and manufactured to comply in all respects with BS 7671:2018 (IET Wiring Regulations 18th Edition: 2018)

QUALITY ASSURANCE

The system is manufactured to BS EN ISO 9001

Classifications to BS EN 50085-1:2005+A1:2013 and BS EN 50085-2-1:2006+A1:2011 available on request

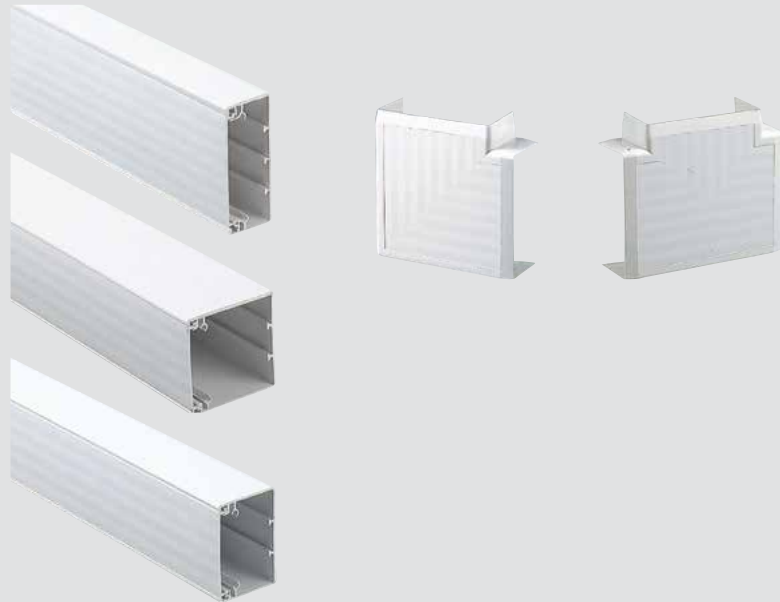

FEATURES

- Wide range of integrated components maximise versatility in application
- Simple, clean lines
- Easy to assemble and install
- Data bend option 32mm radius
- High impact resistance and durability
- Tapered joints provide complete protection at junctions masking cut ends
- Clip on covers provide continuous access for wiring modifications
- All extrusions manufactured from 100% recycled material*

Description

Premier is an integrated PVCu trunking system for general cable distribution. A comprehensive range of tees, angles and junctions make a very wide range of configurations possible and the system can be wall or ceiling mounted.

6 trunking sizes are available (see dimensions overleaf) offering the user distribution solutions, from incoming mains to the most remote power, telecom or data outlet.

Cable segregation (see figure 1) Each trunking profile incorporates a series of preformed locators which accept clip-in dividers for cable segregation. Clip-in components are provided for retaining cables within each compartment prior to trunking lids being fitted.

FINISH

Premier lid components are decoratively textured in contrasting linear patterns giving a subtle 'striped' effect.

All other components are in white with a semi matt finish.

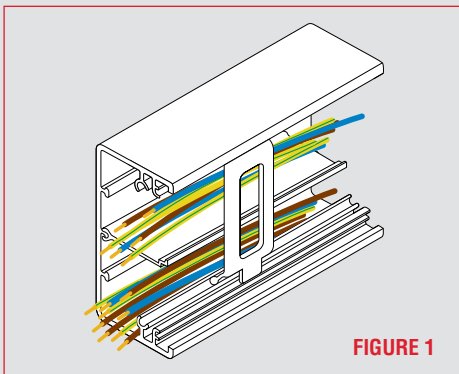

FIGURE 1

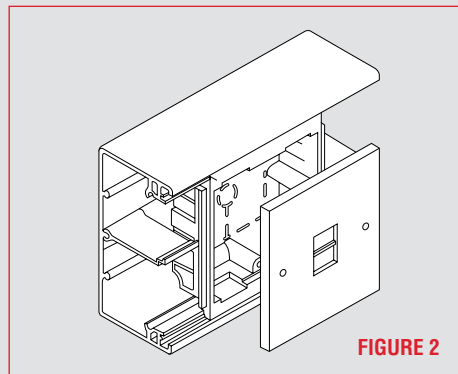

FIGURE 2

* Based on 2014 consumption

For a full range of corresponding products,
see pages 338-343 in the product selector.

Integrated Trunking

Dimensions (mm)

TRUNKING SYSTEMS

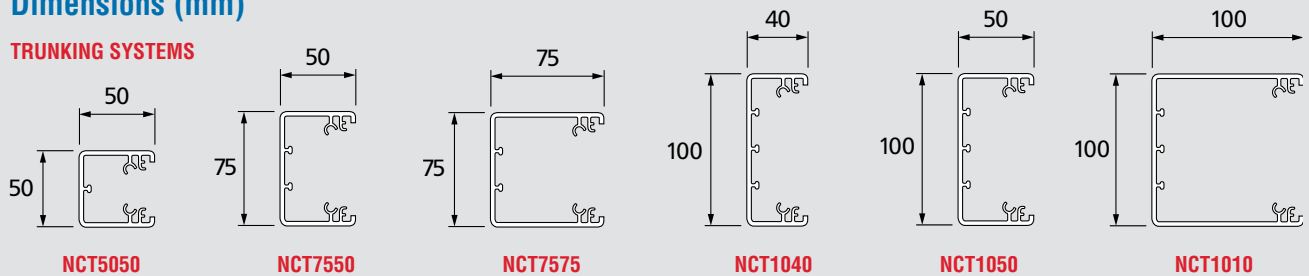

PREMIER CABLE CAPACITY																								
TYPE OF CONDUCTOR	SIZE	CABLE FACTOR	NCT5050	NCT7550	NCT7575	NCT1040	NCT1050	NCT1010	NCT1040 WITH 25MM BACKBOX	NCT1050 WITH 25MM BACKBOX	NCT1050 WITH 35MM BACKBOX	NCT1010 WITH 25MM BACKBOX	NCT1010 WITH 35MM BACKBOX											
			Full Term CSA 100% Fill (MM ²)																					
			1881	3039	4754	3091	4041	8725	1081	1866	1224	6550	5908											
TERM AT 45% FILL (MM ²)																								
			846	1367	2139	1390	1818	3926	486	839	550	2947	2658											
POWER CABLES			NUMBER OF CABLES AT 45% FILL																					
PVC stranded	1.5mm ²	8.6	98	158	248	161	211	456	56	97	63	342	309											
	2.5mm ²	12.6	67	108	169	110	144	311	38	66	43	233	210											
	4mm ²	16.6	50	82	128	83	109	236	29	50	33	177	160											
	6mm ²	21.2	39	64	100	65	85	185	22	39	25	139	125											
DATA CABLES			NUMBER OF CABLES AT 45% FILL (A) AND FULL CAPACITY (B)																					
			A	B	A	B	A	B	A	B	A	B	A	B	A	B	A	B	A	B	A	B		
Cat 5E UTP	5.5mm dia.	30.2	28	62	45	100	70	157	46	102	60	133	130	288	16	35	27	61	18	40	97	216	88	195
Cat 5E STP	6.0mm dia.	36.0	23	52	37	84	59	132	38	85	50	112	109	242	13	30	23	51	15	34	81	181	73	164
Cat 6 UTP	6.5mm dia.	42.2	20	44	32	72	50	112	32	73	43	95	93	206	11	25	19	44	13	29	69	155	62	140
Cat 6 STP	7.0mm dia.	49.0	17	38	27	62	43	97	28	63	37	82	80	178	9	22	17	38	11	24	60	133	54	120

Applications

The Premier system is ideal for use in factories, workshops, schools, portable accommodation and general commercial buildings where integration of cable distribution with accessory mounting facility is desirable.

Generally systems can be used as follows:

50 x 50, 75 x 50 and 75 x 75mm – general cable distribution.

100 x 40 and 100 x 50mm – where mounting accessories are also required.

100 x 100mm – where mounting accessories and/or generous cable distribution is required.

ACCESSORIES		
	FOR USE WITH	LIST NO.
ONE GANG ACCESSORY BOX AND FRAME	NCT1040, NCT1050, NCT1010 for power and ELV outlets requiring 25mm deep box NCT1050/NCT1010 for power and ELV outlets requiring 35mm deep box	VTS6025
	NCT1040, NCT1050, NCT1010 for power and ELV outlets requiring extra deep accessory space	VTS6035
		VTS6000
TWO GANG ACCESSORY BOX AND FRAME	NCT1040, NCT1050, NCT1010 for power and ELV outlets requiring 25mm deep box NCT1050/NCT1010 for power and ELV outlets requiring 35mm deep box	VTS7025
	NCT1040, NCT1050, NCT1010 for power and ELV outlets requiring extra deep accessory space	VTS7035
		VTS7000
THREE GANG ACCESSORY BOX	NCT1040, NCT1050, NCT1010 for power and ELV outlets requiring 28mm deep box	VTS8028
MINI TRUNKING ADAPTOR	Integrates Premier with YEA1, YEA2, YEA3 CMA1, CMA3, CMA4 Mini trunking fittings	NYT100



Technical Hotline
+44 (0)1268 563720

Premier Technical

CABLE MANAGEMENT
PERIMETER AND
DISTRIBUTION

Integrated Trunking

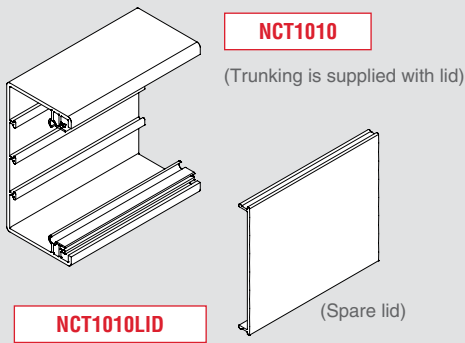

PROFILE	END CAP
50 x 50	NEP5050
75 x 50	NEP7550
75 x 75	NEP7575
100 x 40	NEP1040
100 x 50	NEP1050
100 x 100	NEP1010

PROFILE	INT CORNER	WITH DATA CORNER
50 x 50	NAI5050	
75 x 50	NAI7550	
75 x 75	NAI7575	
100 x 40	NAI1040	
100 x 50	NAI1050	NDAI1050
100 x 100	NAI1010	

PROFILE	FLAT TEE	WITH DATA CORNER
50 x 50	NTF5050	
75 x 50	NTF7550	
75 x 75	NTF7575	
100 x 40	NTF1040	
100 x 50	NTF1050	NDTF1050
100 x 100	NTF1010	

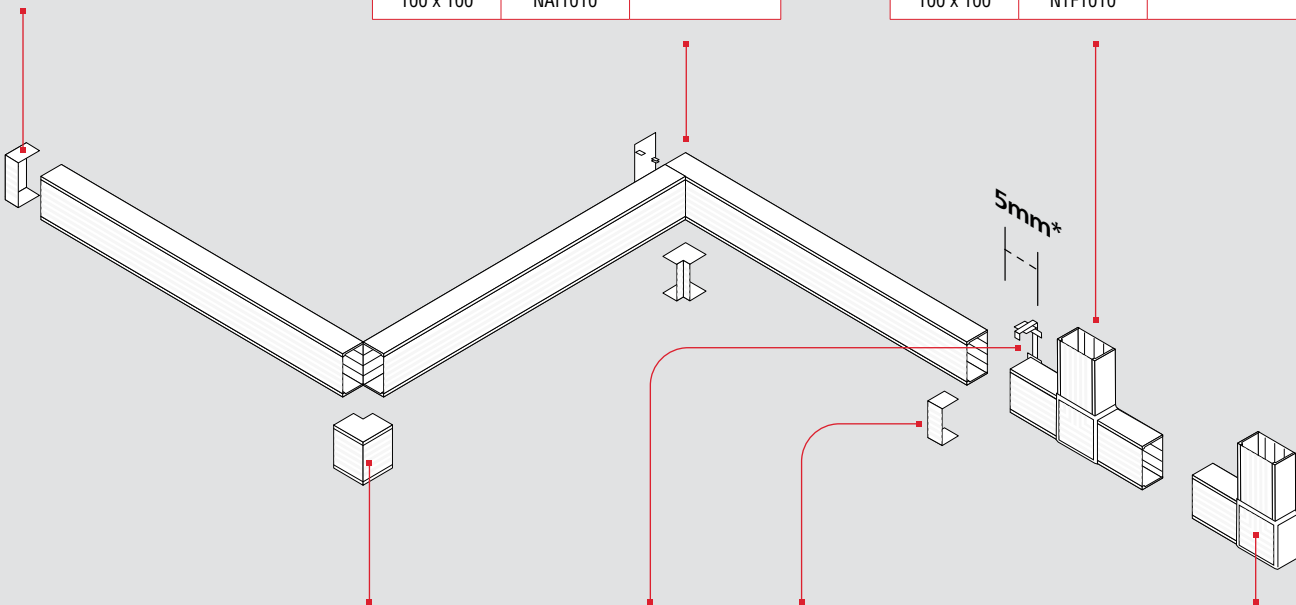

PROFILE	EXT CORNER	WITH DATA CORNER
50 x 50	NAE5050	
75 x 50	NAE7550	
75 x 75	NAE7575	
100 x 40	NAE1040	
100 x 50	NAE1050	NDAE1050
100 x 100	NAE1010	

PROFILE	INT COUPLER	JOINT COVER
50 x 50	NCI5050	NJC5050
75 x 50	NCI7550	NJC7550
75 x 75	NCI7575	NJC7575
100 x 40	NCI1040	NJC1040
100 x 50	NCI1050	NJC1050
100 x 100	NCI1010	NJC1010

PROFILE	FLAT ANGLE	WITH DATA CORNER
50 x 50	NAF5050	
75 x 50	NAF7550	
75 x 75	NAF7575	
100 x 40	NAF1040	
100 x 50	NAF1050	NDAF1050
100 x 100	NAF1010	

Note: Diagram shows profile 1050

* Minimum distance

Integrated Trunking

Installation Guide

GENERAL NOTES

Prior to installation strike a line of trunking using a plumb and chalk line for vertical, and spirit levels for horizontal runs.

- 1 It may be advantageous to fit stop ends to trunking prior to installation. Where stop end could be subjected to lateral force the mounting clip should be solvent welded to the rail.
- 2 Drill Trunking with oversized holes in positions and at maximum centre shown.
- 3 Fix with dome head screws and fibre or rubber washers. Allow for expansion movement when tightening screws and between joints.

- 4 Internal coupler should be used to ensure correct alignment. Clip the coupler to the end of the free trunking length, offer up to the fixed trunking and slide home.

- 5 Minimum dimensions:

Trunking size mm	Dimension A (mm)
50 x 50	100
75 x 50	100
75 x 75	130
100 x 40	90
100 x 50	100
100 x 100	210

Fixing Centres (2)

For 50mm wide trunking use hole A.

For 100mm wide trunking use holes A and B.

For 75mm wide trunking drill single fixing on the centre line.

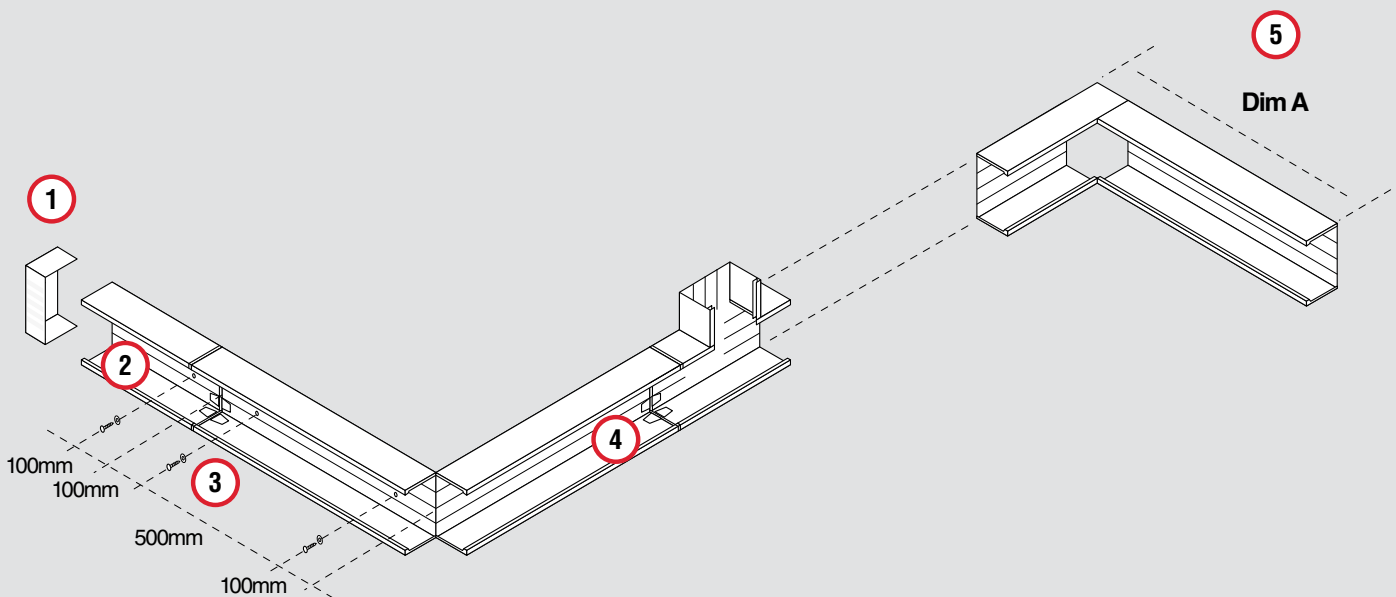
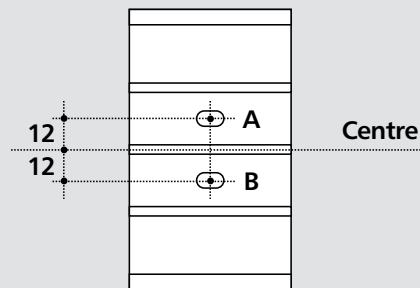



Technical Hotline
+44 (0)1268 563720

Premier Technical

Integrated Trunking

Installation Guide Continued

- 8 Clip in cable dividers prior to cabling. Divider clip fits to the tee bar mounting rail extruded on the trunking base. To correctly fit divider, the extension foot of the female clip profile is mounted below the tee bar for horizontal runs, and to the right hand side of vertical runs.
- 9 Cable retainers clip into the semi-circular grooves extruded within the trunking profile. Retainers should be installed at 750mm maximum centres on straight runs or within 100mm of each end, corner or change of plane.
- 10 Internal corners – measure distance into corner and cut trunking length 2mm short.
- 11 Wall plates should be used to maintain enclosure function of trunking.
- 12 Leave a gap of 20mm to allow fitting of joint cover moulding.

AT INTERNAL CORNERS, EXTERNAL CORNERS, FLAT ANGLES AND FLAT TEES, LEAVE GAPS BETWEEN LIDS AND THE END TRUNKING BODY AS SHOWN BELOW:

		50X50	75X50	75X75	100X40	100X50	100X100
EXTERNAL CORNER	A	62	62	87	52	62	140
FLAT TEE	B	74	99	99	124	124	124
	C	65	90	90	115	115	115
INTERNAL CORNER	D	62	62	87	52	62	140
FLAT ANGLE	E	66	90	90	115	115	140

