

Lo-Carbon Sentinel Kinetic Cooker Hood

- Acoustic Top Box option for reduced in-duct noise
- Recognised in SAP PCDB
- Includes Cooker Hood Canopy
- Horizontal duct option for space-saving installations
- Fits within a 600mm wide aperture (300mm deep)
- Integrated digital controller for simple and accurate commissioning
- Plug and play controls; Humidistat, Wireless Remote
- BMS connectivity
- LS inputs (Light Switch)
- Volt-free inputs
- Self diagnosis for simplified fault finding
- Adjustable delay On/delay Off timer



Easy Installation

Ducting can be attached to the unit horizontally, vertically or both. Minimum internal depth of kitchen cupboard: 300mm.

Horizontal and Vertical Spigots: The combination of spigot options allows installation in confined locations. If vertical and horizontal connection are required on the same outlet/inlet, additional spigots can be supplied.

The condensate connection can be taken through the rear of the unit or through the side of the unit into an adjacent cupboard prior to connection into pre-installed domestic waste water system.

Cooker Hood Unit

The Sentinel Kinetic Cooker Hood is designed to fit in a 600mm wide aperture above a hob. The telescopic hood incorporates two flat removable metal grease filters, low energy light bulbs and is available with a White or Brushed Aluminium front trim.

The hood contains an integral fire damper in accordance with BRE Digest 398 and is connected to the heat recovery unit by a galvanised steel duct with access for cleaning. When the hood is opened, the heat recovery unit goes to boost speed and the summer bypass automatically opens to prevent cooking by-products entering the heat recovery cell. As an additional safety feature, the duct also contains a thermal cut-out fuse which turns off the MVHR unit in the event of excessive temperature in the airway. Cooker Hood units cannot be handed on-site and must be purchased as left hand (L) or right hand (R) models.

SELV Models

SELV cooker hoods allow the distance between the hood and an electric hob to be reduced from 650mm to 550mm.

Integral Humidity Sensor

The integral humidity (models with H suffix) sensor increases speed in proportion to relative humidity levels, saving energy and reducing noise. The sensor also reacts to small but rapid increases in humidity, even if

the normal trigger threshold is not reached. This unique feature ensures adequate ventilation, even for the smallest wet room. The night time relative humidity setback feature suppresses nuisance tripping as humidity gradually increases with falling temperature.

Models

Lo-Carbon Sentinel Kinetic with summer bypass and humidity sensor.

Model	Stock Ref
Kinetic CWH L (White Left)	446756
Kinetic CSH L (Brushed Aluminium Left)	446757
Kinetic CWH R (White Right)	446758
Kinetic CSH R (Brushed Aluminium Right)	446759
Kinetic CWH L SELV (White Left)	477003
Kinetic CSH L SELV (Brushed Aluminium Left)	477004
Kinetic CWH R SELV (White Right)	477005
Kinetic CSH R SELV (Brushed Aluminium Right)	477006

Accessories

Model	Stock Ref
Wired Remote Controller	443283
LED Alarm with 15m cable	448356
Opto-coupler for volt-free bms connection	447340
ISO 45% Coarse (G3) 2x Filter	442356
ISO ePM10 50% Pollen (M5) 1x Filter	444199
Grease 2x Filter	372774
Acoustic Purge Fan	477988
Acoustic Purge Fan XL	479829

SAP PCDB Test Results

	SAP 2009		SAP 2012	
	Thermal Efficiency %	SFP (W/l/s)	Thermal Efficiency %	SFP (W/l/s)
K+1	85	0.72	85	0.78
K+2	85	0.74	85	0.89
K+3	84	0.83	82	1.03
K+4	83	0.92		

SEC Class

Model	SEC Class
Kinetic CWH/CSH	A

Performance

Fan speeds are fully adjustable within the performance range.

Horizontal Spigots

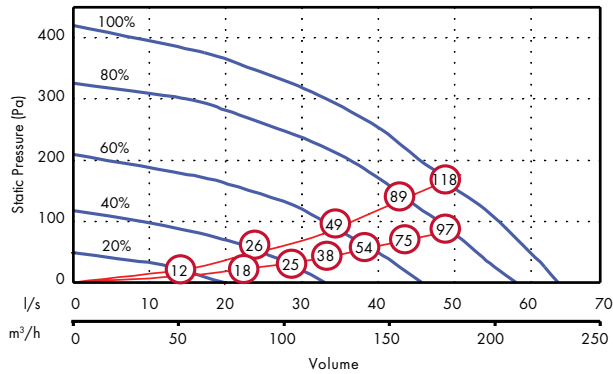

Vertical Spigots

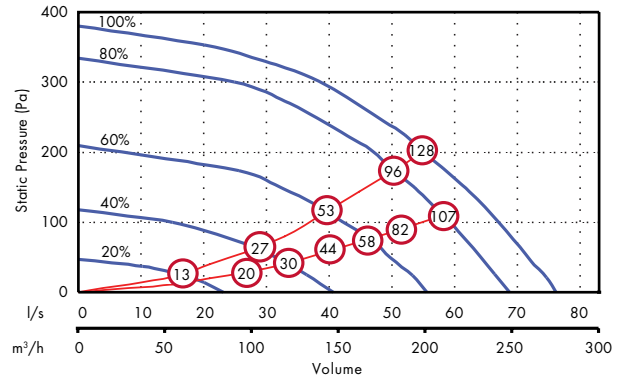

x figure relates to Wattage (both motors)

Dimensions (mm)

Unit

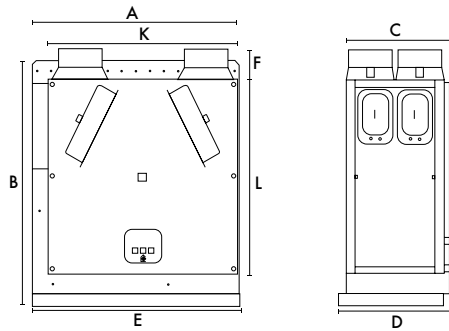

Minimum clearance from the bottom of this unit to the top of the hob must be:
 Gas: 750mm
 Electric: 650mm/ 550mm (SELV)

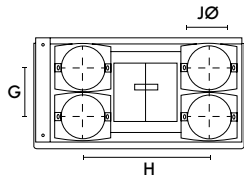

A	B	C	D	E	F	G	H	JØ	K	L	kg
590	710	295	316	598	90	140	360	125	550	550	27

Sound Data

Flow l/s	Test mode	Octave band, Hz, dB SWL								SPL dB(A) @ 3m
		63	125	250	500	1K	2k	4K	8K	
10	Supply	47.8	40.2	38	31.1	28.2	22.1	23.6	30.9	21.4
	Extract	47	38.7	36	29.9	25	22.4	23.3	30.8	20.6
	Breakout	43.6	36.2	37.4	30.9	27.4	23.3	24.2	31.4	18.6
20	Supply	54	46.6	50.2	44.5	44.4	38.3	28.8	31.9	31.2
	Extract	46.8	40.5	34.6	34.2	34.6	25.9	23.7	30.3	22.9
	Breakout	45.9	39.9	40.6	35.7	33.5	28.4	25.3	31.2	21.3
30	Supply	58.1	54.5	57.6	52.2	51.7	47.6	38.6	35.8	38.5
	Extract	47.6	46.2	38.7	41.3	42.8	33.9	26.4	30.5	28.4
	Breakout	45.2	42.4	48.2	40.8	37.7	35.2	30	31.1	25.2
40	Supply	65.2	58.4	62.3	58	56.5	52.5	44.1	41.4	43.6
	Extract	53.5	53	44	47.7	48.1	39.7	31.5	31.5	33.5
	Breakout	50.9	47.6	47.4	48.1	42.5	40.8	36.3	34.4	29.3
50	Supply	66.4	63.2	66.3	62.5	61.7	57.4	50	47.8	48.3
	Extract	64.2	55.2	48	50.9	52.1	44.5	35.9	35	37.2
	Breakout	55	51	51.3	51.6	46.9	46.0	42	38.3	33.2

Tested according to BS EN 13141-7:2010. Breakout quoted spherical. Supply and Extract quoted hemispherical. For in-duct data, end reflections are added based on the spigot size of the unit.

Consultant's Specification

Operation

The supply and extract ventilation unit shall be a Sentinel Kinetic as manufactured by Vent-Axia and shall be sized as indicated on the drawings and shall be in accordance with the particular specification.

Supply air to the room shall be pre-heated by the extract air via the integrated composite plastic counterflow heat recovery cell. The Sentinel Kinetic shall automatically vary the ventilation rate via EC/DC motors, as it receives signals from one of the optional interconnected sensors. When a signal is received, the fans shall either vary their speed proportionally or on a trickle and boost principle.

The unit shall have the facility to commission the supply and extract fans individually via in-built minimum and maximum speed adjustment, or alternative wired remote control unit. The fans themselves shall have independent, infinitely variable speed control.

Unit Specification

The unit shall be manufactured with an ABS outer case construction, and incorporate a metal duct to the cooker hood, intumescent fire damper and thermal switch, in accordance with BRE Digest 398.

The unit shall have a high efficiency composite plastic counterflow heat exchanger, supply and extract filters, automatic summer bypass, integral minimum and maximum infinitely variable speed controls with fascia mounted failure indication. The unit shall have low energy, high efficiency EC/DC fan/motor assemblies with sealed for life bearings. The impellers shall be high efficiency forward curved centrifugal type.

The unit shall have a heat exchanger cell with a thermal efficiency of up to 92% when tested to EN 308. This shall be protected by ISO 45% Coarse (G3) Filter 2pk grade synthetic filters on supply and extract. Complete with a condensate drip tray and drain connection.

The unit shall be constructed with a removable Core allowing full maintenance access. The removable Core shall provide access to the following:

- ✓ Supply and extract filter
- ✓ Heat exchanger
- ✓ Access to the electrical connections

Access shall be provided for wiring termination and setup/commissioning. The backlit LCD user interface therein shall be removable for remote mounting if required.

Units shall be as manufactured by Vent-Axia Ltd.

Sound tested to BS EN 13141-7:2010

Standard Controls

All Sentinel Kinetic units shall incorporate the following functions integrally mounted, pre-wired and factory fitted by the manufacturer:

- ✓ Integral infinitely variable fan speed control on supply and extract
- ✓ Integral min/max ventilation control/set point
- ✓ Integral BMS interfaces - control and status indication
- ✓ Heating interlocks
- ✓ 0-10V proportional speed adjustment
- ✓ Volt free contacts
- ✓ 24V sensor supply
- ✓ Integral on/off or trickle boost function from remote switch e.g. PIR occupancy detector
- ✓ The unit shall be controlled by the 'Sentinel' control devices (enablers and sensors) as detailed in the schedule or on the drawings
- ✓ Fully automatic summer bypass
- ✓ Switched Live input with adjustable 'Delay-On' feature

- ✓ Fan failure or component failure indicated via individual fault code display
- ✓ Running time counter
- ✓ Control panel PIN number lock
- ✓ Automatic frost protection effective to -20°C
- ✓ Tool free filter access
- ✓ The unit shall incorporate ('H' models) an integral humidity sensor with the following features:
 - Ambient Response; Raises the humidity trigger point as dwelling temperature reduces
 - Rapid Response; Monitors the rate of change in humidity and triggers increased airflow even if the humidity trigger threshold is not reached
 - Proportional Response; Incrementally increases the fan speed to reduce noise and reduce energy consumption

Integral Cooker Hood Specification

The Sentinel Kinetic Cooker Hood shall consist of a telescopic Hood and galvanised steel duct connection to the MVHR Unit.

The Hood construction shall be of grey powder coated steel with Brushed Aluminium or White painted fascia.

The Hood shall trigger the MVHR unit to a pre-defined boost speed and open the summer bypass when opened, and shall have two low-energy lamps illuminating the hob top.

Filter shall be a flat metal grease filter, removable for cleaning.

The galvanised steel ductwork shall provide a continuous fire barrier between the Hood and the MVHR unit. It shall contain an Intumescent fire damper, thermal cut-out and volume balancing damper. The thermal cut-out shall switch off the MVHR unit at a pre-defined safety temperature.

The duct shall have an access panel for cleaning by the end-user.

Mounting Option



Airflow Direction

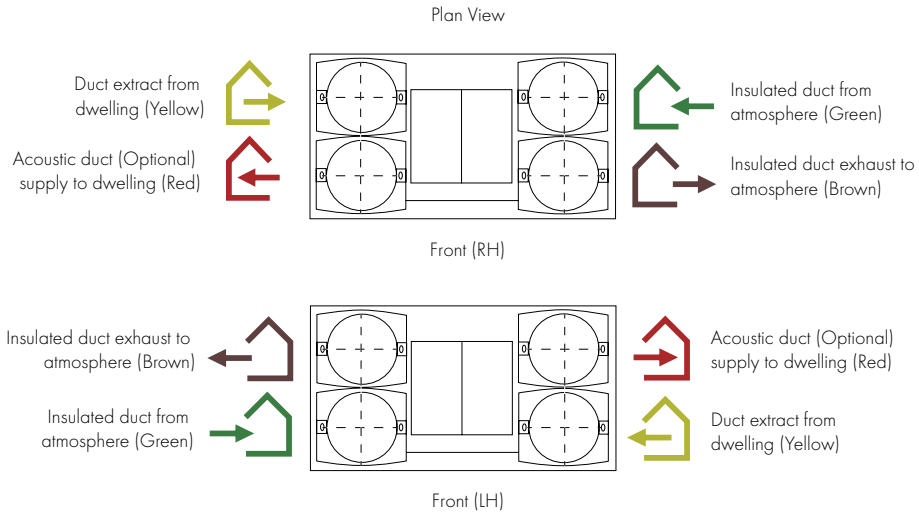

Electrical Connection

Please note: Electrical connection should be carried out by an appropriately qualified person and in accordance with current wiring regulations.

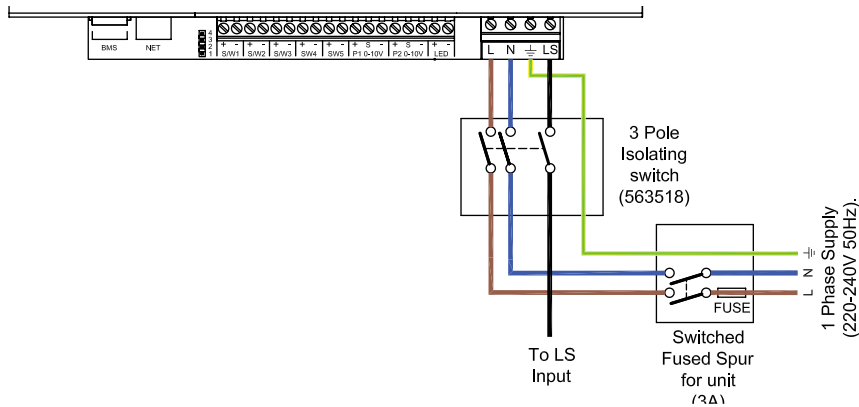

Trickle to Boost by a Light Circuit

