

Cable Ties

Standard Range

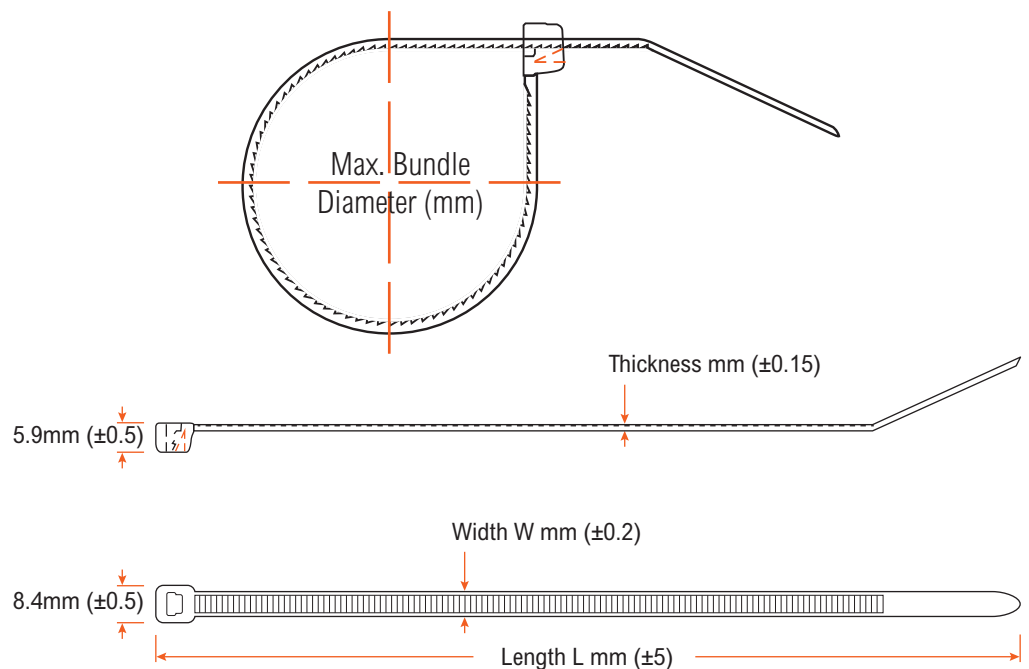

• Options:	Natural or Black.
• Material:	Nylon 66.
• Temperatures:	Operating Temperature: -40°C to +85°C. Tightening Temperature: -10°C to +60°C. Max. Admissible Point: +110°C (For Short Time). Fusion Temperature: +256°C.
• Limit Oxygen Index (LOI):	27%.
• Flammability Rating:	UL 94 Class V2.
• Dielectric Strength:	50,000 Volts/mm.
• Weather Resistance:	High resistance to bases, oils, greases, oil derivatives, chloride solvents; limited resistance to acids; not resistant to phenols; halogen-free resins.
• Comply With:	BS EN50146, BE EN 62275:2009, DIN EN 62275(VDE0604-201):2010-07, IEC 62275(2006-10).
• UL Approved:	E474504.
• Characteristics:	<ul style="list-style-type: none"> • Krimpterm Cable Ties are produced in UL Approved Nylon 6.6 giving excellent Flexibility and Mechanical Strength. • The Black Cable Ties have added Carbon Black enabling them to be UV Stable and suitable for Outdoor Use and giving excellent resistance to weathering and ageing. • High tensile strength with low insertion force.
• Example Applications:	Electrical installations, Industrial Wiring, Automotive, Panel building.



See product technical table on next page

Cable Ties

Standard Range

Item No.	Colour	Width W (mm)	Thickness (mm)	Length L (mm)	Max. Bundle Diameter (mm)	Min. Tensile Strength (kg)
CT25-B	Black	4.8	1.5	120	27	22
CT3-B	Black	4.8	1.6	160	39	22
CT49-B	Black	4.8	1.35	190	50	22
CT5-B	Black	4.8	1.5	203	52	22
CT26-B	Black	4.8	1.5	250	68	22
CT30-B	Black	4.8	1.5	280	77	22
CT8-B	Black	4.8	1.5	300	83	22
CT10-B	Black	4.8	1.5	368	105	22
CT31-B	Black	4.8	1.5	385	110	22
CT12-B	Black	4.8	1.5	432	125	22
CT54-B	Black	4.8	1.5	450	131	22
CT55-B	Black	4.8	1.6	500	147	22
CT32-B	Black	4.8	1.5	550	162	22
CT33-B	Black	4.8	1.8	635	189	22
CT51-B	Black	4.8	1.8	730	216	22
CT25-W	Natural	4.8	1.5	120	27	22
CT3-W	Natural	4.8	1.6	160	39	22
CT49-W	Natural	4.8	1.35	190	50	22
CT5-W	Natural	4.8	1.5	203	52	22
CT26-W	Natural	4.8	1.5	250	68	22
CT30-W	Natural	4.8	1.5	280	77	22
CT8-W	Natural	4.8	1.5	300	83	22
CT10-W	Natural	4.8	1.5	368	105	22
CT31-W	Natural	4.8	1.5	385	110	22
CT12-W	Natural	4.8	1.5	432	125	22
CT54-W	Natural	4.8	1.5	450	131	22
CT55-W	Natural	4.8	1.6	500	147	22
CT32-W	Natural	4.8	1.5	550	162	22
CT33-W	Natural	4.8	1.8	635	189	22

STORAGE AND USAGE OF NYLON CABLE TIES

Krimpterm cable ties are made from high quality Nylon 66 resin. Moisture absorption is an essential factor for this material to retain its strength and maintain optimal performance. To this end, it is important for the cable ties to be kept in a sealed package wherever possible.

Below are some helpful storage suggestions:

1. The ideal storage temperature is around 23°C with the humidity over 50%.
2. Do not open the bag before use. Please try to finish the whole package of cable ties shortly after opening or reseal the bag until you are ready to use again.
3. Do not expose directly under sunlight (except UV weather resistant cable ties).
4. Avoid storing cable ties close to warm objects (such as heaters).