

### Main

Range of product	Modicon ABE7
Product or component type	Electromechanical output relay sub-base
[Us] rated supply voltage	24 V DC for PLC end
Number of channels	16
Number of terminal per channel	2

### Complementary

Terminal block type	Removable
Polarity distribution	Volt-free
Fixing mode	By clips (35 mm symmetrical DIN rail) By screws (solid plate with fixing kit)
Maximum current per output common	10 A
Current per channel	5 A for preactuator end
Minimum switching current	10 mA at $\geq 5$ V
Drop-out voltage	2.4 V at 20 °C (PLC end)
Switching frequency	$\leq 0.5$ Hz $\leq 10$ Hz
Threshold tripping voltage	19.7 V at 40 °C
Drop-out current	1 mA at 20 °C
Maximum power dissipation per channel in W	0.36 W (PLC end)
Contacts type and composition	1 NO for preactuator end
Maximum switching voltage	250 V AC 50/60 Hz conforming to IEC 60947-5-1 30 V DC conforming to IEC 60947-5-1
Electrical durability	500000 Cycles, maximum switching current: 600 mA at 24 V DC-13 10 ms (preactuator end) 500000 Cycles, maximum switching current: 1500 mA at 230 V AC-12 (preactuator end) 500000 Cycles, maximum switching current: 1500 mA at 24 V DC-12 (preactuator end) 500000 cycles, maximum switching current: 900 mA at 230 V AC-15 (preactuator end)
Electrical reliability	1e-008
Operating time	$\leq 10$ ms coil energisation and NO closing $\leq 5$ ms coil de-energisation and NO opening
Contact bounce time	$\leq 5$ ms 1 NO
Operating rate in Hz	10 Hz no load 0.5 Hz at Ie
Mechanical durability	20000000 cycles
[Uimp] rated impulse withstand voltage	2.5 kV conforming to IEC 60947-1
[Ui] rated insulation voltage	2000 V
Installation category	II conforming to IEC 60664-1
Tightening torque	0.6 N.m with flat $\varnothing$ 3.5 mm screwdriver
Width	206 mm
Net weight	0.405 kg

## Environment

Max immunity to microbreaks	5 ms
Dielectric strength	2000 V conforming to IEC 60947-1
Product certifications	GL CSA DNV UL EAC
IP degree of protection	IP2X conforming to IEC 60529
Protective treatment	TC
Resistance to incandescent wire	750 °C, extinction time <30 s conforming to IEC 60695-2-11
Shock resistance	15 gn for 11 ms conforming to IEC 60068-2-27
Resistance to radiated fields	10 V/m (26000000...1000000000 Hz) conforming to IEC 61000-4-3 level 3
Resistance to fast transients	2 kV level 3 conforming to IEC 61000-4-4
Ambient air temperature for operation	-5...60 °C conforming to IEC 61131-2
Ambient air temperature for storage	-40...80 °C conforming to IEC 61131-2
Pollution degree	2 conforming to IEC 60664-1

## Packing Units

Unit Type of Package 1	PCE
Number of Units in Package 1	1
Package 1 Height	7.000 cm
Package 1 Width	8.200 cm
Package 1 Length	21.100 cm
Package 1 Weight	581.000 g
Unit Type of Package 2	S03
Number of Units in Package 2	15
Package 2 Height	30.000 cm
Package 2 Width	30.000 cm
Package 2 Length	40.000 cm
Package 2 Weight	9.103 kg

## Offer Sustainability

Sustainable offer status	Green Premium product
REACH Regulation	<a href="#">REACH Declaration</a>
EU RoHS Directive	Pro-active compliance (Product out of EU RoHS legal scope) <a href="#">EU RoHS Declaration</a>
Mercury free	Yes
China RoHS Regulation	<a href="#">China RoHS Declaration</a>
RoHS exemption information	<a href="#">Yes</a>
Environmental Disclosure	<a href="#">Product Environmental Profile</a>
Circularity Profile	<a href="#">End Of Life Information</a>
WEEE	The product must be disposed on European Union markets following specific waste collection and never end up in rubbish bins

## Contractual warranty

Warranty	18 months
----------	-----------

Dimensions

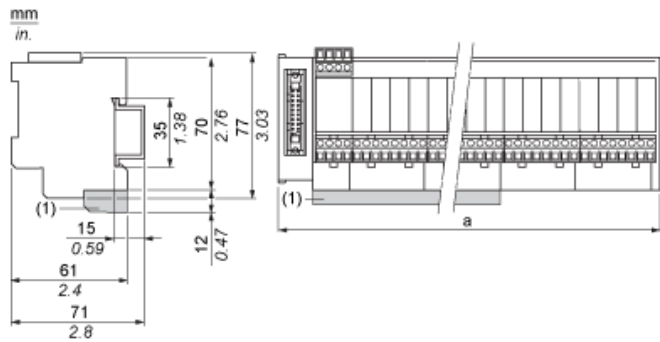

(1) ABE7BV20 / ABE7BV20E

ABE7	a in mm	a in in.
R16S111 / R16S111E	125	4.92
R16S21 / R16S21•E	206	8.11

---

Mounting

---

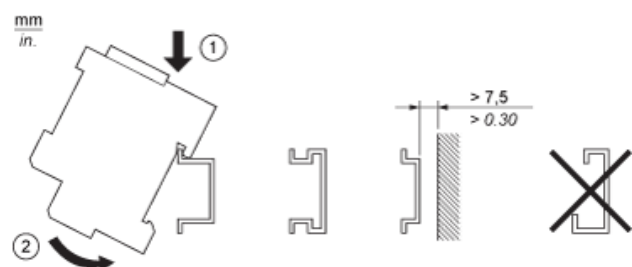

## HE10 16 Channels

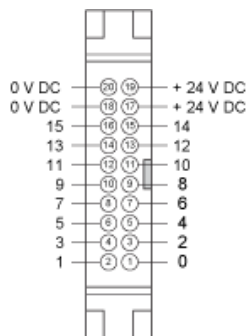

## Wiring Diagram

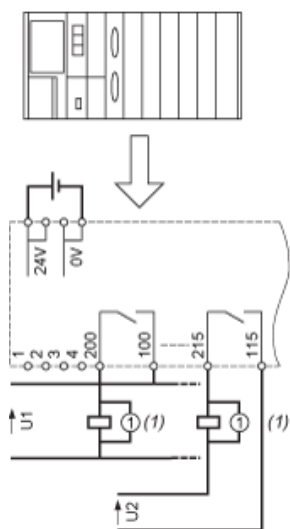

(1) Inductive load

Curves for Determining Cable Type and Length According to the Current

16-channel Sub-base

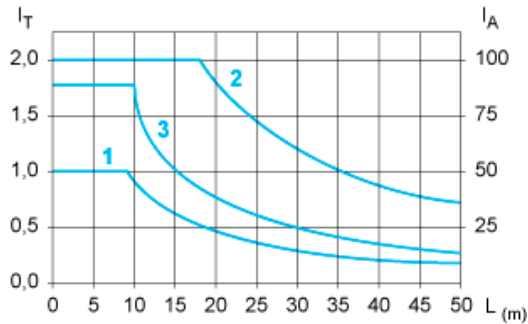

L Cable length

$I_T$  Total current per sub base (A)

$I_A$  Average current per channel (mA)

(1) TSXCDP••2 and ABFH20H••0 cables with c.s.a.  $0.08 \text{ mm}^2$  (AWG 28).

(2) TSXCDP••3 cables with c.s.a.  $0.34 \text{ mm}^2$  (AWG 22).

(3) Cables with c.s.a.  $0.13 \text{ mm}^2$  (AWG 26).

The curves are given for a voltage drop of 1 V in the cable. For n volts tolerance, multiply the length determined from the graph by n.

Electrical Durability (in Millions of Operating Cycles) Conforming to IEC 60947-5-1

DC Loads

DC12 curves

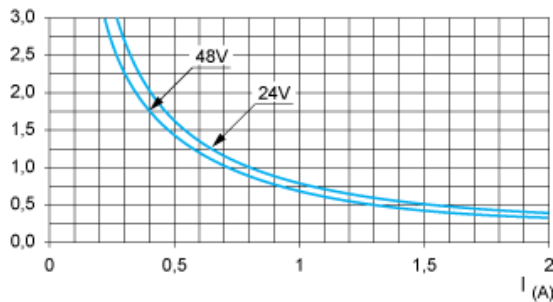

DC12control of resistive loads and of solid state loads isolated by optocoupler,  $I/R \leq 1 \text{ ms}$ .

DC13 curves

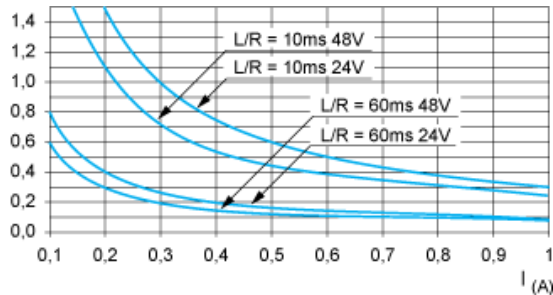

DC13switching electromagnets,  $L/R \leq 2 \times (U_e \times I_e)$  in ms,  $U_e$ : rated operational voltage,  $I_e$ : rated operational current (with a protective diode on the load, DC12 curves must be used with a coefficient of 0.9 applied to the number in millions of operating cycles)

## AC Loads

### AC12 curves

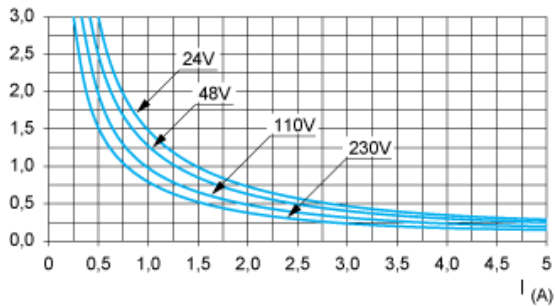

AC12 control of resistive loads and of solid state loads isolated by optocoupler,  $\cos \phi \geq 0.9$ .

### AC14 curves

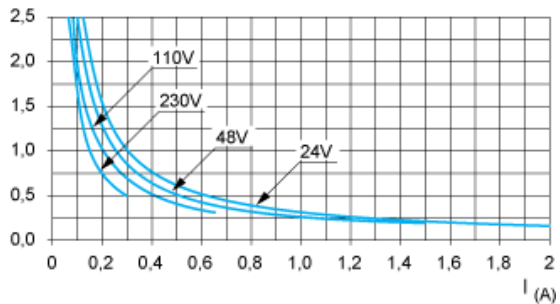

AC14 control of small electromagnetic loads  $\leq 72$  VA, make:  $\cos \phi = 0.3$ , break:  $\cos \phi = 0.3$ .

### AC15 curves

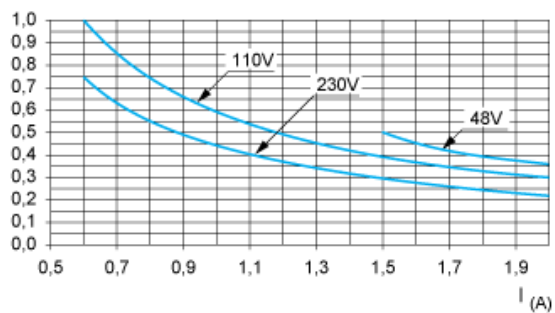

AC15 control of electromagnetic loads  $> 72$  VA, make:  $\cos \phi = 0.7$ , break:  $\cos \phi = 0.4$ .