

230 V~	1200 W	5,2 A	300 W	1,3 A	300 W	1,3 A

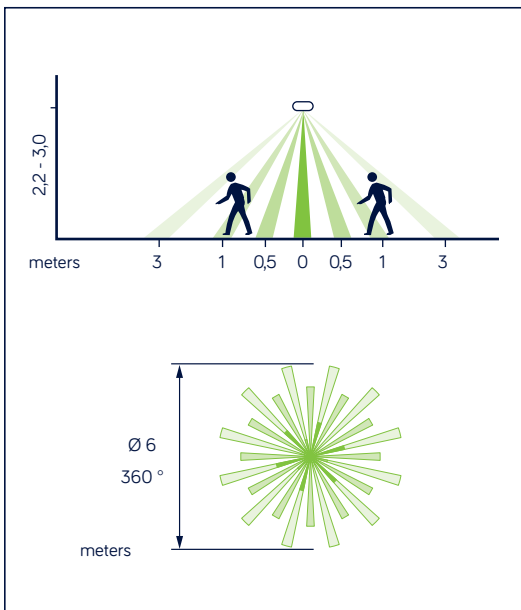

	220 - 240 V~
	50 / 60 Hz
	2 x 1,5 mm ² Recommended use of a soft wire
	-20°C / +40°C
	PIR
	2 000 LUX
	10 sec
	3 m x 3 m

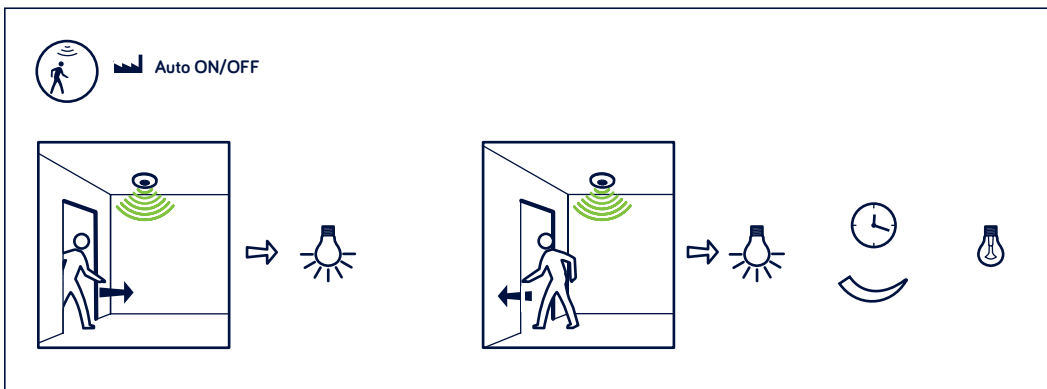

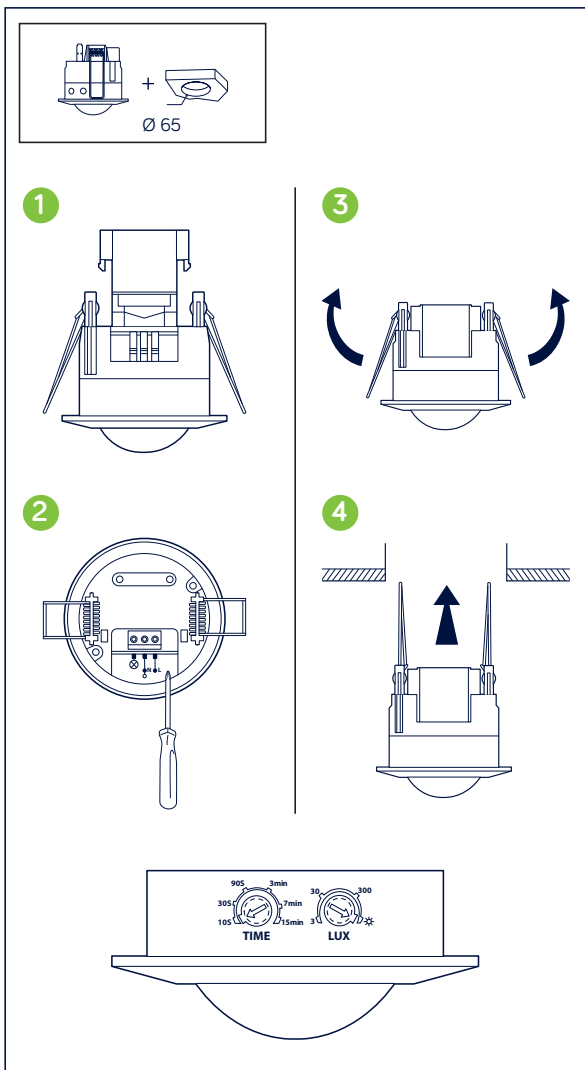
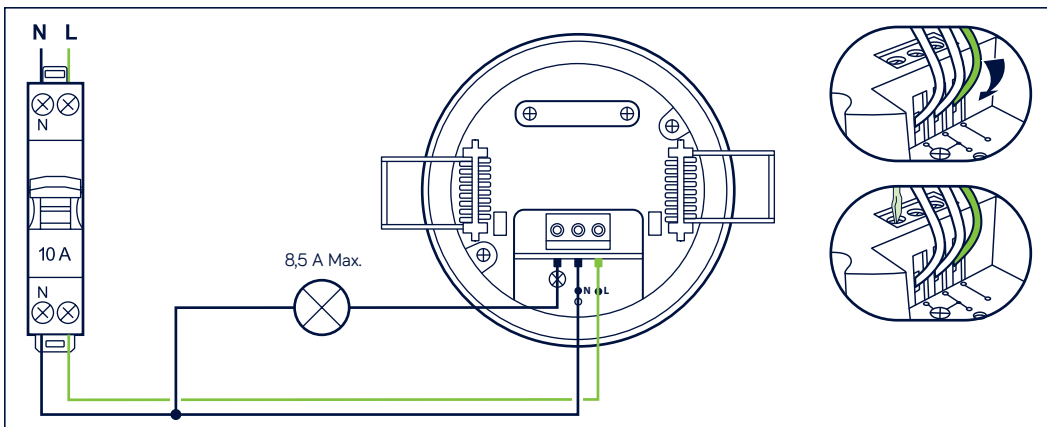

• **Installation and connection:**

Install the sensor in a suitable place where its performance will not be affected by direct hot air flow (e.g. from a heater), direct sunshine or other disturbing factors.

1. Select a suitable location, preferably across the monitored area, up to 3m in height.
2. Switch off the main power supply, connect the wires according to the diagram and then connect the sensor to the junction box.
3. Use the switch to set the desired parameters of the sensor.

• **Setting time (switch-off delay)**

The desired operating time (lighting) of a light can be continuously adjusted within the range of 10 seconds +/- 3 seconds to 15 minutes +/- 120 seconds. Every motion during this period will trigger a new cycle.

When adjusting the detection zone and testing the function, it is recommended to set the shortest time.

• **Twilight setting (light sensitivity)**

You can adjust the desired light sensitivity continuously within the range of approx. 3 LUX to 2 000 LUX.

Warning

This device should be installed by a qualified electrician in accordance with the latest edition of the IET wiring regulations.