

# LB PLUS busbar trunking systems

technical information

## ■ Hangers and cable channel

**60 kg suspension bracket for Type A busbar Cat. No. 75003000**

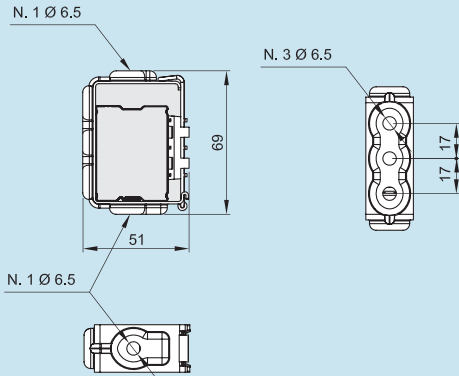

**60 kg suspension bracket for Type B busbar Cat. No. 75003004**

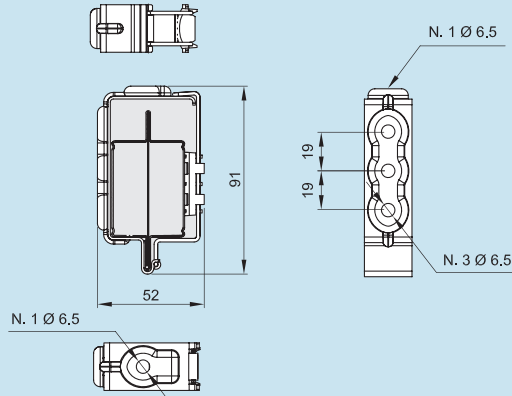

**Hook for lamp Cat. No. 75003001**

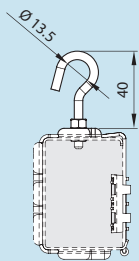

**Ring Cat. No. 75003002**

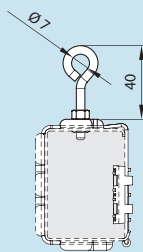

**Pig tail for chain Cat. No. 75003005**

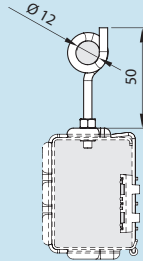

**Bracket with 3 m steel cable for Type A busbar Cat. No. 75003009**

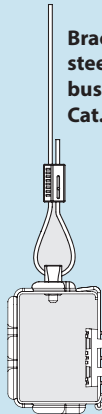

**5 m steel cable with self-locking clamp for Type B busbar Cat. No. 75003008**



### Bracket for cable channel

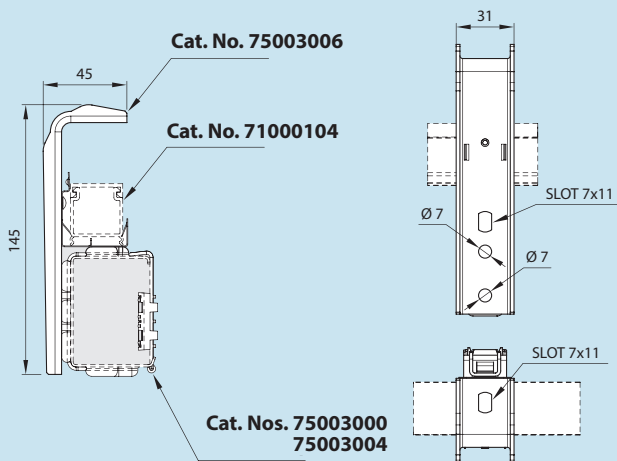

**PVC cable channel with cover Cat. No. 71000104**

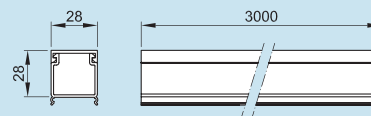

## LB PLUS busbar trunking systems

### installation methods

LB PLUS requires a fixing bracket Cat. No. 75003000 for Type A and a fixing bracket Cat. No. 75003004 for Type B  
Both brackets come with a 6.5 mm Ø hole and can be fixed to 6 mm<sup>2</sup> threaded rod

#### ■ Suspension

For suspension, the bracket must be fitted with a range of appropriate accessories, which must be added according to the installation requirements

#### Ceiling suspension of LB PLUS Type A

##### Pigtail for chain

This solution is possible by ordering suspension bracket item Cat. No. 75003000 and accessory Cat. No. 75003005, preset for the connection of a chain



##### Bracket with steel cable

This solution is already supplied as a kit Cat. No. 75003009, consisting of a suspension bracket and a 3 m steel cable



#### Ceiling suspension of LB PLUS Type B

##### 5 m cable with self locking clamp

This accessory Cat. No. 75003008 allows the suspension of the reinforced (Type B) straight lengths using the slots along the reinforcement plate at the top of the bar

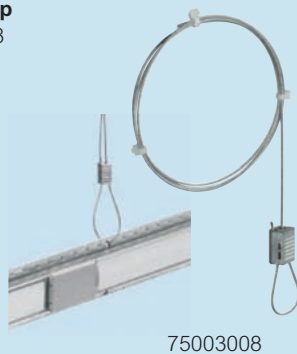

#### ■ Suspension of light fittings

##### LB PLUS - single and double sided

For the suspension of light fittings, use hook Cat. No. 75003001 or ring Cat. No. 75003002  
These accessories can be installed on the brackets used for the suspension of the busbar (Cat. Nos. 75003000 and 75003004).

