

VITM4-2CH-2S

Vitesse Modular 4 - 2 Ch / 2 supply Switching Modules

Overview

- The Vitesse modular system is a cost effective method of providing power and control for lighting installations in industrial, commercial and retail buildings. The system is designed for ease of installation: mains input is connected using the spacious wiring compartment; control inputs and outputs are pluggable using industry standard connectors. The modular approach allows for between 4 and 16 luminaires to be connected.
- The VITM4-2CH-2S is a two channel, non-dimming distribution box for use in applications that require two independent supplies for switching lighting or lighting and ventilation circuits. For example this product is ideal for installations that have essential and non-essential supplies for lighting circuits and require common switching using presence detectors. This product provides connections for separate Live, Neutral and Permanent Live inputs.

System Components

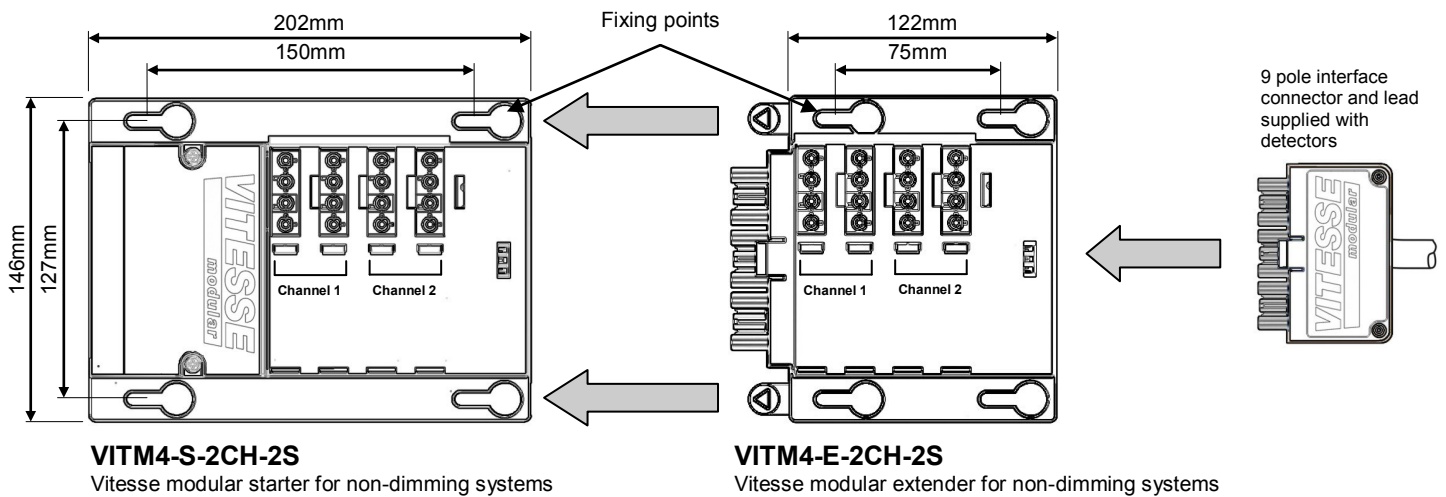

Height - allow 150mm for total height of unit (including connectors and cable)

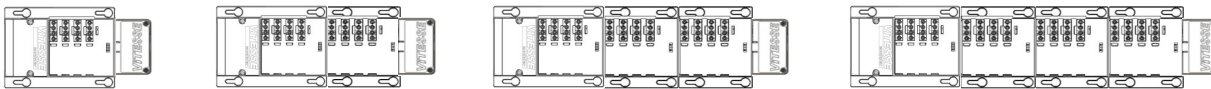

Installation

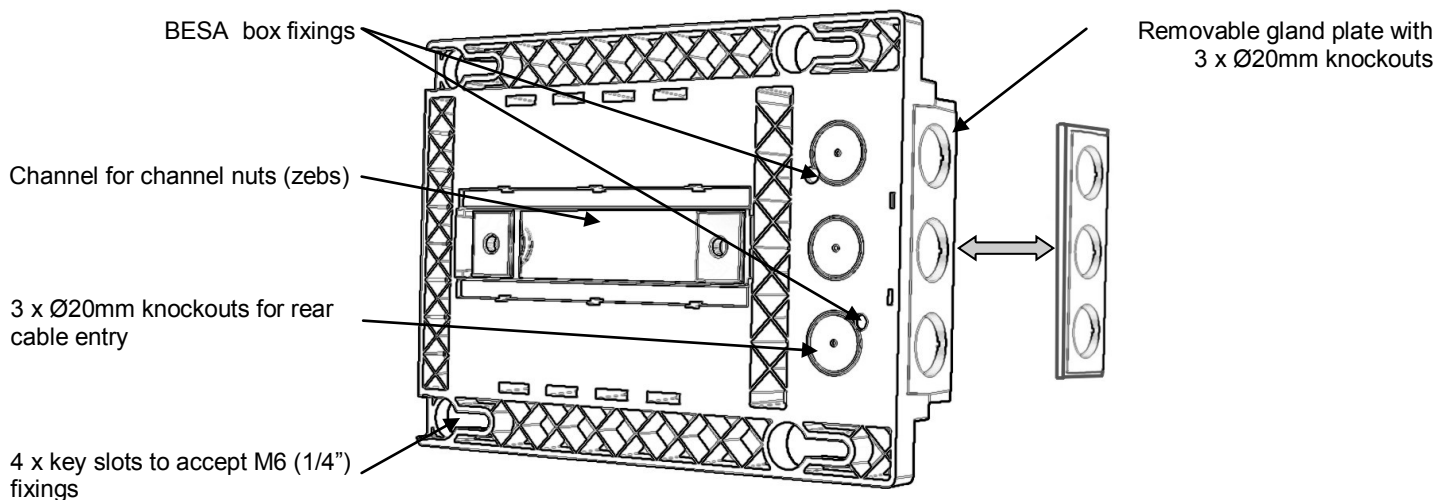

Warning. This device works at mains voltage. Be sure to take care when working with electricity.

- The box should be fixed on a smooth, flat surface or using drop rod fixings attached to channel nuts.
- Ensure that there is easy access to the wiring compartment and all connectors once the box is in-situ.

Wiring

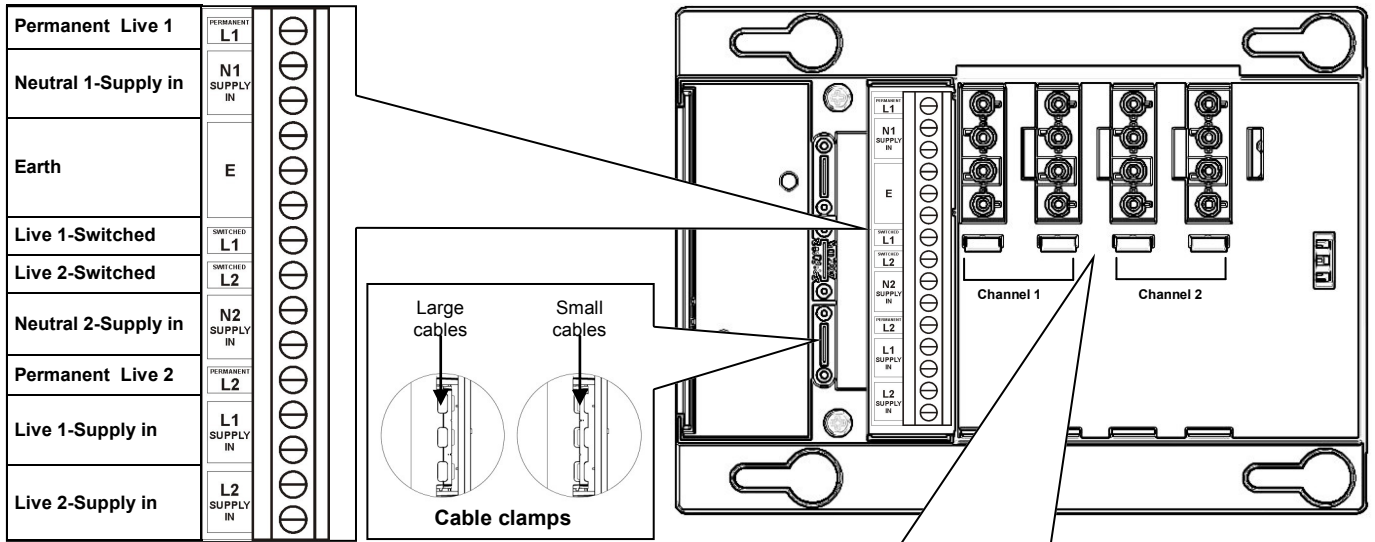

- All wiring should be mains rated.
- Remove wiring compartment cover.
- Wire the box using the diagrams below
Switched live turns the lights on and off
- Use the cable clamps to secure the wiring or use cable glands (not supplied). The clamps can be split, and flipped over to clamp different cable diameters.
- Replace wiring compartment cover.
- Plug in the luminaires ensuring that the connector latches to the box.

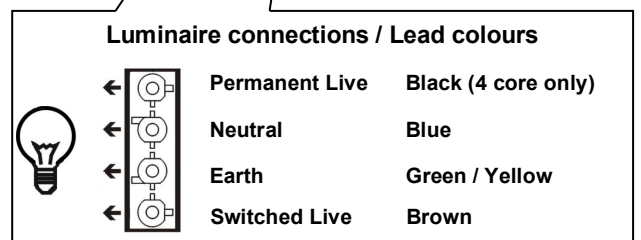

Connecting a detector

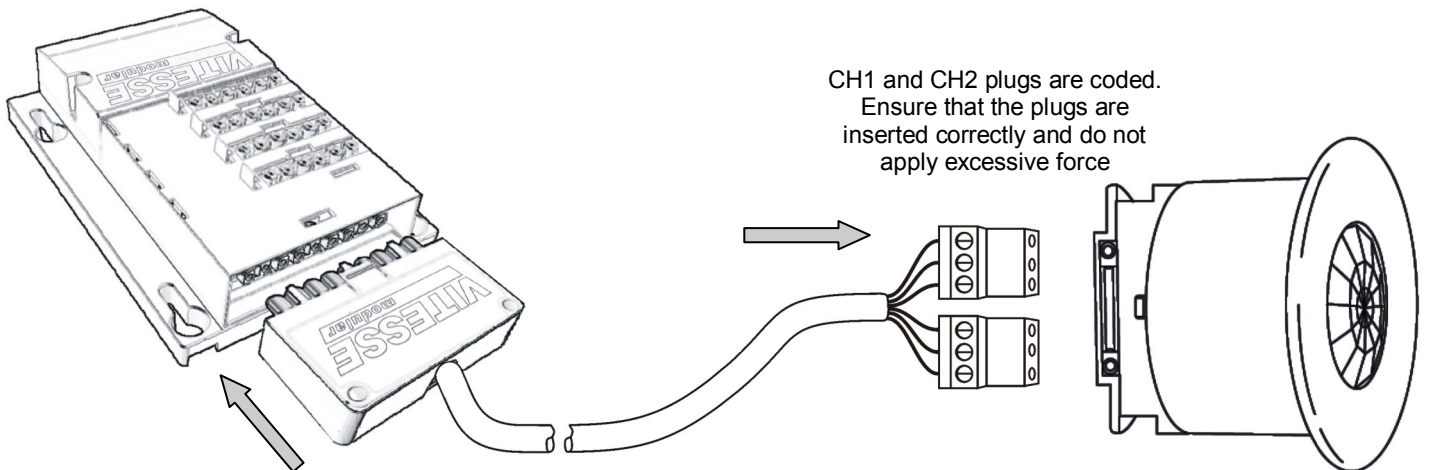

Detector lead needs to be ordered separately from the detector. Order code VITM4-L3-2CH-2S.
 Where two detectors connect to a single box a dual lead is available VITM4-LD3-2CH-2S.

Local emergency test switch

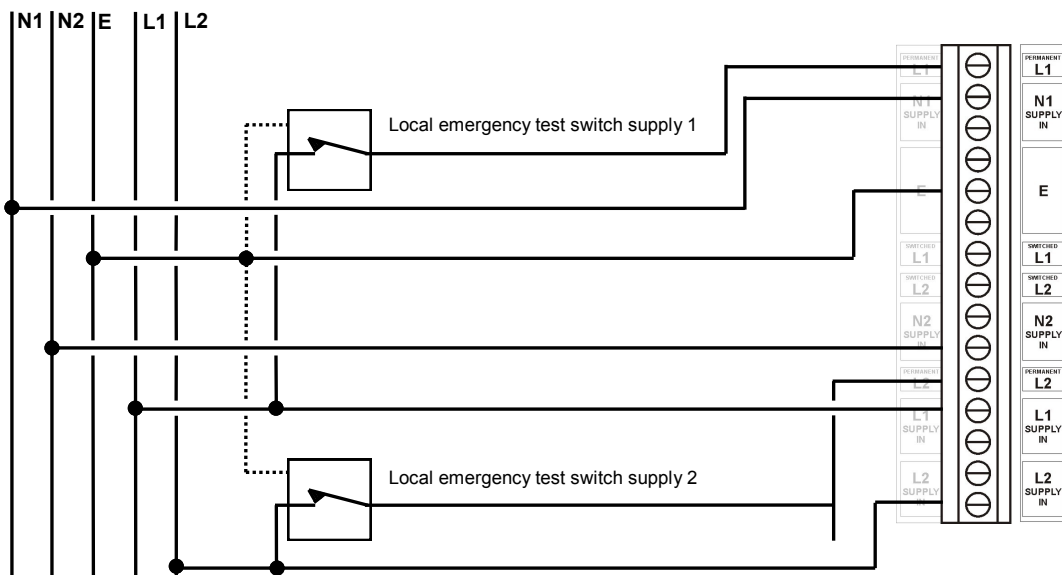

Emergency test using central switch

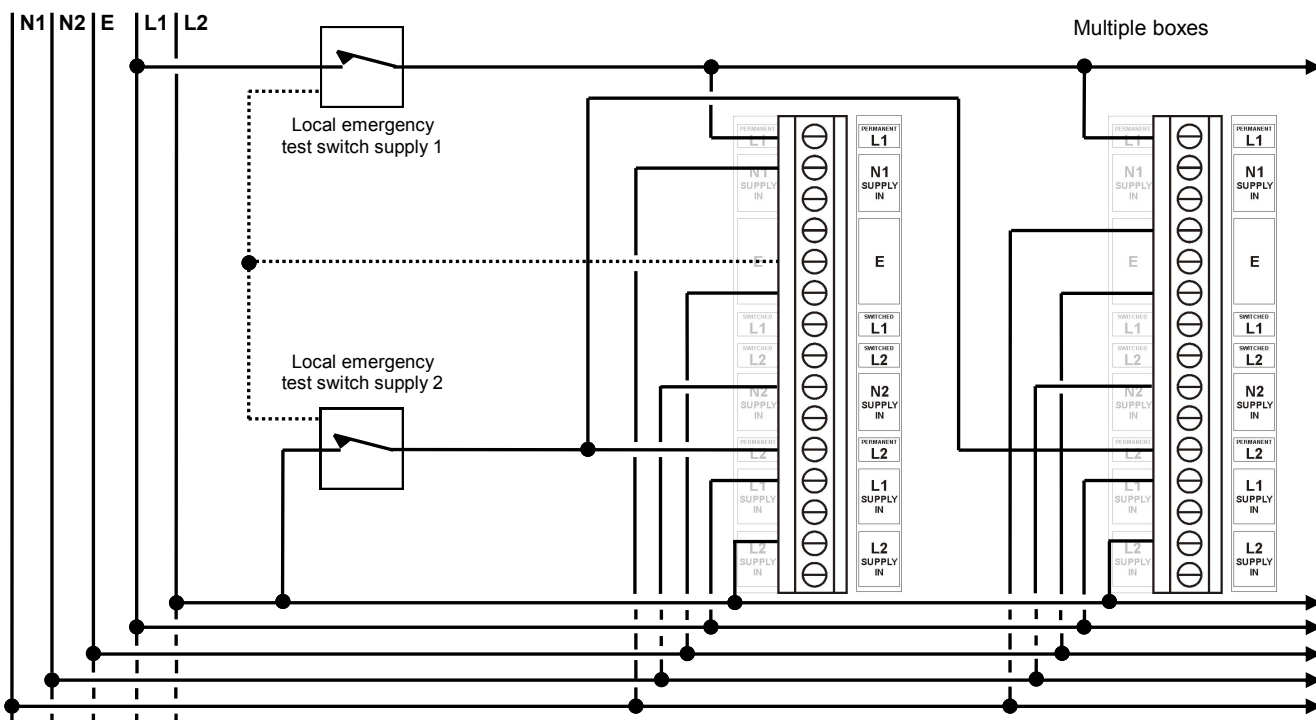

Emergency test using power interruption

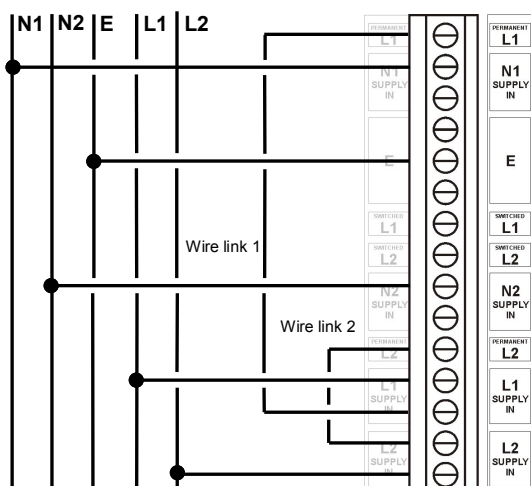

A local lighting switch may still be used when there is a central emergency test switch or when a circuit breaker is used to interrupt the power.



DO NOT WIRE ACROSS PHASES

Applications

2 Channel detectors

The flexibility of using two channels detectors allows the following scenario:

- Channel 1 - occupancy and lux
Channel 1 of the detector can be used to switch the Channel 1 luminaires at a preset lux level. These luminaires are typically situated nearest the windows. The luminaires will also switch with occupancy.
- Channel 2 - occupancy only
The inner luminaires, ie those furthest from the windows, are switched with occupancy only.

Presence detectors

- The unit can only be used in presence mode only, ie automatic on, automatic off.

The diagrams below illustrate a typical application.

Window / room switching

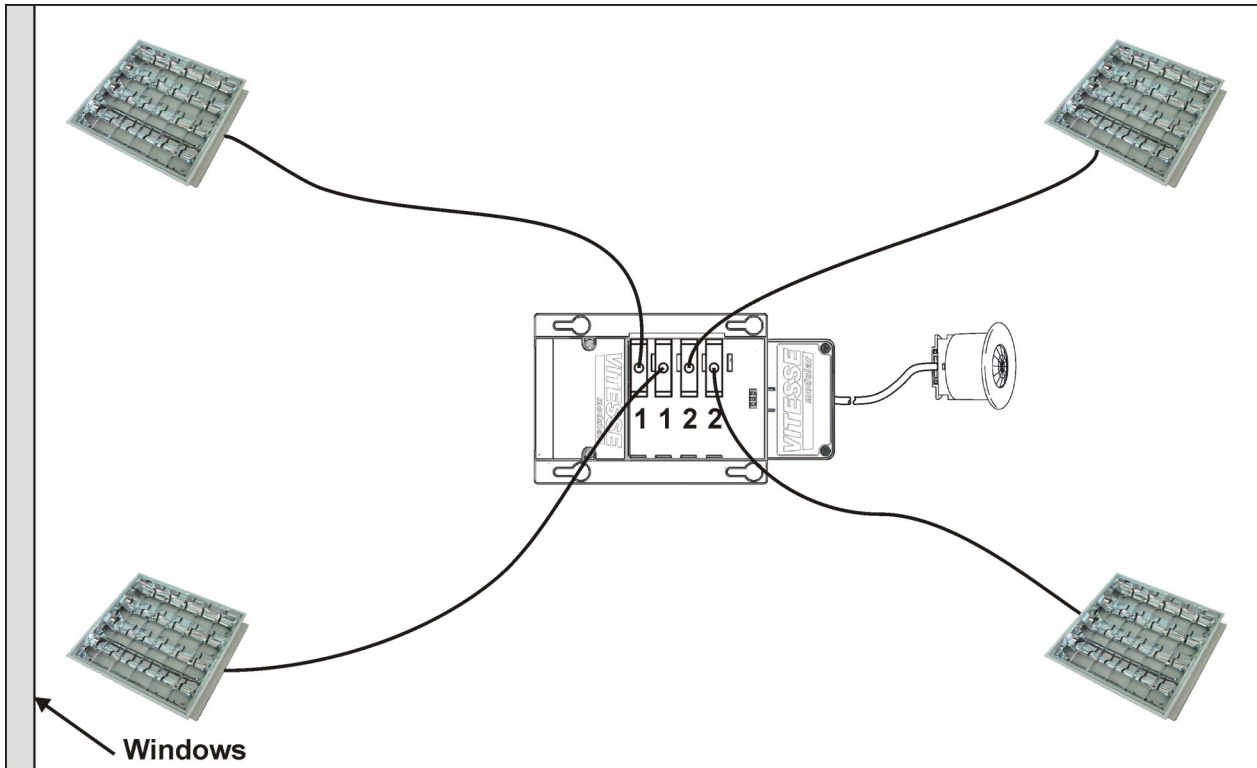

Window / room switching + Extender

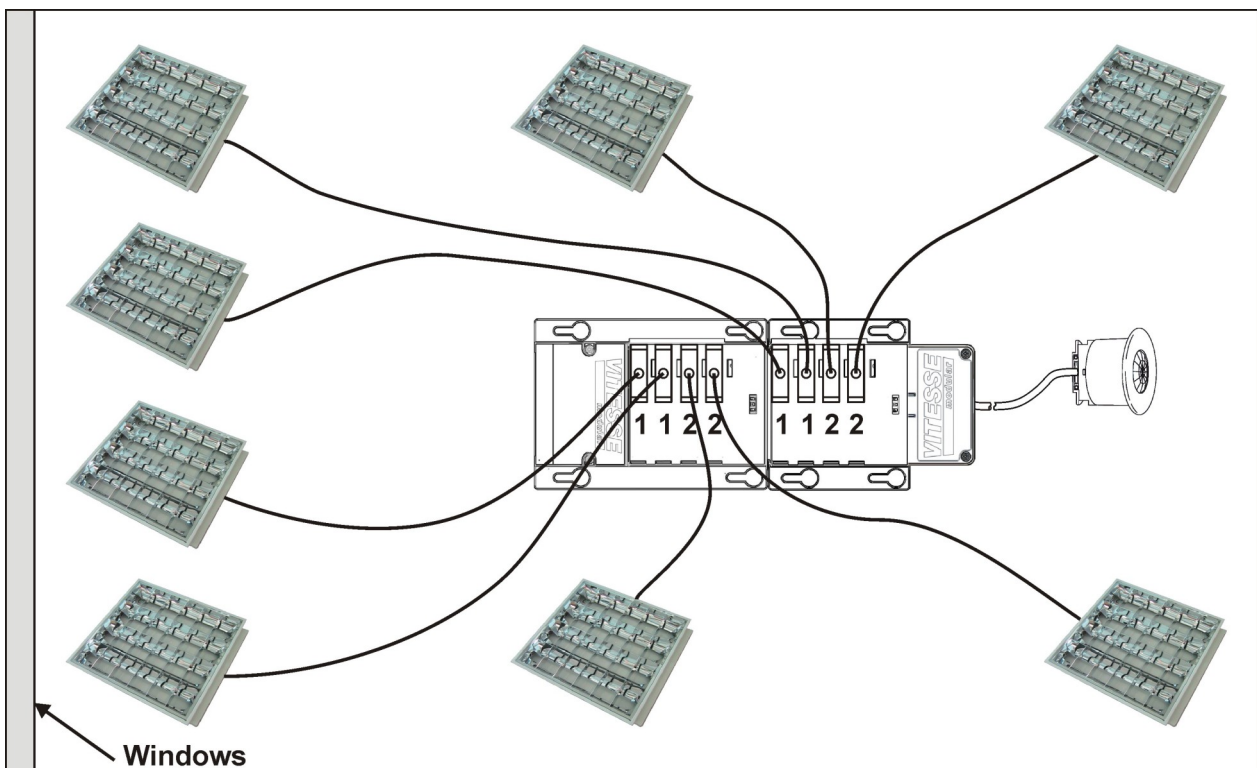

This page intentionally left blank

This page intentionally left blank

This page intentionally left blank

Part numbers

Presence / Absence Detectors

EBDSPIR-PRM-2CH	PIR 2-Channel presence detector
EBDSPIR-PRM-2CH-NC	PIR 2-Channel presence detector, normally closed fail safe contacts
MWS3A-PRM-2CH	Microwave 2-Channel presence detector
MWS3A-PRM-2CH-NC	Microwave 2-Channel presence detector, normally closed fail safe contacts
MWS6-PRM-2CH	Microwave 2-Channel presence detector
MWS6-PRM-2CH-NC	Microwave 2-Channel presence detector, normally closed fail safe contacts

Modules

VITM4-S-2CH-2S	4 pole starter box, 2 channel, 2 supplies
VITM4-E-2CH-2S	4 pole extender box, 2 channel, 2 supplies

Detector Leads (LSF)

VITM4-L3-2CH-2S	3m 2 channel sensor lead, 2 supplies
VITM4-LD3-2CH-2S	3m 2 channel dual detector sensor lead, 2 supplies

Luminaire Leads (LSF)

VITM4L303100W	3 core	3m	1.0mm ² White plug
VITM4L305100W	3 core	5m	1.0mm ² White plug
VITM4L403100R	4 core	3m	1.0mm ² Red plug
VITM4L405100R	4 core	5m	1.0mm ² Red plug

Other leads available to order.

Connectors

VITM4-LPW	4 pole luminaire plug white
-----------	-----------------------------

Ratings

Voltage	230VAC +/- 10%
Frequency	50Hz
Terminal capacity	4mm ² in wiring compartment
Temperature	0°C to 35°C
Power	Rating of system 16A. Rating of each output 10A Note: detector may have different rating, check datasheet
Compliance	BS 5733:1995



UK Patent no. GB2463063
EU patent pending
EU registered design no.
001587544-0001, 001587544-0002

For lighting purposes only with suitable circuit protection. For fixed wiring only

IMPORTANT NOTICE!

This device should be installed by a qualified electrician in accordance with the latest edition of the IEE wiring regulations.



C.P. Electronics Ltd
Brent Crescent
London
NW10 7XR
United Kingdom
Tel: + 44 (0) 333 900 0671
Fax: + 44 (0) 333 900 0674
www.cpelectronics.co.uk
enquiry@cpelectronics.co.uk