Wireless and batteryless limit switches XCMW range

Catalogue



Simply easy!™

Limit switches

XCMW range
Wireless and batteryless limit switches
Miniature format

- **Selection guide** pages 2 to 5

- **XCMW range, miniature format**
 - General presentation pages 6 and 7
 - Description of limit switches page 8
 - Characteristics of limit switches page 9
 - References of limit switches page 10
 - References of ready-to-use packs page 11
 - References of receivers page 11
 - References of network access points page 12
 - References of accessories page 13
 - Dimensions pages 14 and 15

- **Product reference index** page 16

Limit switches

XCMW range
Wireless and batteryless limit switches
Miniature format

Product type Transmitters: plunger head and rotary head limit switches



Actuator type	Metal end plunger	Steel roller plunger	Thermoplastic roller lever	Steel roller lever
---------------	-------------------	----------------------	----------------------------	--------------------

Radio transmission	Transmission protocol	ZigBee® Green Power at 2.405 GHz (Channel 11, IEEE 802.15.4)
Maximum range	100 m in free field 300 m with a relay antenna in free field	
Transmission power	3 mW	
Activation time	30 ms	
Transmission time	< 7 ms	

Certifications and directives	Product certifications	EN/IEC 60947-5, EMC directive 2004/108/EC, R&TTE directive 1999/5/EC, UKCA, CE
Radio approvals	FCC (USA), IC (Canada), ACMA and RSM (Australia and New Zealand), MIC (Japan), ANATEL (Brazil: pending)	

Mechanical characteristics	Mechanical life	400,000 operating cycles
Maximum operating rate	3,600 operating cycles per hour	
Maximum tripping force	13 N	
Materials	Plastic bodies, metal heads	

Environment	Ambient air temperature	Operation: -25...+55 °C Storage: -40...+70 °C
Degree of protection	IP65 conforming to EN/IEC 60529	
Degree of protection	IK04 conforming to EN/IEC 50102	

Electromagnetic compatibility (EMC)	Electrostatic discharge	8 kV (air) and 6 kV (contact) conforming to IEC 61000-4-2	
	Electromagnetic fields	Test condition: from 2,000 to 2,700 MHz, conforming to EN/IEC 61947-5-1 and IEC 61000-4-3	
		Test level: 1 V/m	Test condition: from 1,400 to 2,000 MHz, conforming to IEC 61000-4-3, EN 301-489-1, and EN 301-489-3
		Test level: 3 V/m	Test condition: from 80 to 1,000 MHz, conforming to IEC 61000-4-3, EN 301-489-1, and EN 301-489-3
	Radiated emissions	Conforming to standards EN 300-440-1 and EN 300-440-2	

References	XCMW110	XCMW102	XCMW115	XCMW116
------------	---------	---------	---------	---------

Page 10

(1) Adjustable throughout 360° in 5° steps, or in 90° steps by reversing the notched washer.
(2) Adjustable throughout 360° in 5° steps, or in 45° steps by reversing the lever mounting.
(3) Value taken with actuation by moving part at 100 mm from the fixing.

Product type Transmitters: plunger head and rotary head limit switches



Actuator type	Variable length thermoplastic roller lever (1)	Variable length steel roller lever (1)	Thermoplastic roller lever, Ø 50 mm (1)	Variable length thermoplastic roller lever, Ø 50 mm (1)	Round thermoplastic rod lever, Ø 6 mm (2) (3)
---------------	------------------------------------------------	----------------------------------------	-----------------------------------------	---------------------------------------------------------	-----------------------------------------------

Radio transmission	Transmission protocol	ZigBee® Green Power at 2.405 GHz (Channel 11, IEEE 802.15.4)
Maximum range	100 m in free field 300 m with a relay antenna in free field	
Transmission power	3 mW	
Activation time	30 ms	
Transmission time	< 7 ms	

Certifications and directives	Product certifications	EN/IEC 60947-5, EMC directive 2004/108/EC, R&TTE directive 1999/5/EC, UKCA, CE
Radio approvals	FCC (USA), IC (Canada), ACMA and RSM (Australia and New Zealand), MIC (Japan), ANATEL (Brazil: pending)	

Mechanical characteristics	Mechanical life	400,000 operating cycles
Maximum operating rate	3,600 operating cycles per hour	
Maximum tripping force	0.5 N.m	
Materials	Plastic bodies, metal heads	

Environment	Ambient air temperature	Operation: -25...+55 °C Storage: -40...+70 °C
Degree of protection	IP65 conforming to EN/IEC 60529	
Degree of protection	IK04 conforming to EN/IEC 50102	

Electromagnetic compatibility (EMC)	Electrostatic discharge	8 kV (air) and 6 kV (contact) conforming to IEC 61000-4-2	
	Electromagnetic fields	Test condition: from 2,000 to 2,700 MHz, conforming to EN/IEC 61947-5-1 and IEC 61000-4-3	
		Test level: 1 V/m	Test condition: from 1,400 to 2,000 MHz, conforming to IEC 61000-4-3, EN 301-489-1, and EN 301-489-3
		Test level: 3 V/m	Test condition: from 80 to 1,000 MHz, conforming to IEC 61000-4-3, EN 301-489-1, and EN 301-489-3
	Radiated emissions	Conforming to standards EN 300-440-1 and EN 300-440-2	

References	XCMW145	XCMW146	XCMW139	XCMW149	XCMW159
------------	---------	---------	---------	---------	---------

Page 10

Limit switches

XCMW range
Accessories for wireless and batteryless
limit switches

Product type		Receivers for wireless radio communication		
				
Maximum number of transmitters		2	32	32
Number and type of outputs		2 PNP outputs	4 PNP outputs	2 time delay relay outputs
Radio transmission	Transmission protocol	ZigBee® Green Power at 2.405 GHz (Channel 11, IEEE 802.15.4)		
	Maximum range	100 m in free field 300 m with a relay antenna in free field		
	Response time	< 30 ms		
Certifications and directives	Product certifications and radio approvals	EN/IEC 60947-5, UL 508, CSA C22.2 No. 14, CCC, EAC, EMC directive 2004/108/EC, R&TTE directive 1999/5/EC, FCC, RSS, C-Tick, ANATEL, SRRC, CE, UKCA	EN/IEC 60947-5, UL 508, CSA C22.2 No. 14, CCC, EAC, EMC directive 2004/108/EC, R&TTE directive 1999/5/EC, FCC, RSS, C-Tick, ANATEL, SRRC, CE, UKCA	
Power supply	Nominal supply voltage	24 V \pm (-15...+15%)	24...240 V \sim / \pm (-10...+10%)	
Output characteristics	Nominal current and voltage	0.2 A/24 V \pm	0.3 A/48 V \pm 3 A/120 V \sim conforming to IEC 60947-5-1 3 A/250 V \sim conforming to UL 508 and CSA C22.14	
Environment	Ambient air temperature	Operation: -25...+55 °C Storage: -40...+70 °C		
	Degree of protection	IP20 conforming to EN/IEC 60529		
References		XZBWR2STT24	ZBRRC (1)	ZBRRD (1)
Page		11		

(1) Schneider Electric products

Access points for wireless and batteryless limit switches		Accessories		
		Relay antenna	External antenna for ZBRN1 and ZBRN2	Communication module for ZBRN1
				
				
60	60	-	-	-
Ethernet Modbus/TCP communication protocol	Communication via Modbus serial link (2 RS485 ports)	-	-	-
ZigBee® Green Power at 2.405 GHz (Channel 11, IEEE 802.15.4)	ZigBee® Green Power at 2.405 GHz (Channel 11, IEEE 802.15.4)	ZigBee® Green Power at 2.405 GHz (Channel 11, IEEE 802.15.4)	-	-
100 m in free field 300 m with a relay antenna in free field	300 m maximum depending on environment	100 m in free field	-	-
< 30 ms	-	-	-	-
EN/IEC 60947-5, UL 508, CSA C22.2 No. 14, CCC, EAC, EMC directive 2004/108/EC, R&TTE directive 1999/5/EC, FCC, RSS, C-Tick, ANATEL, SRRC, CE	CCC, CSA, C-Tick, EAC, UL 508, LV 2006/95/EC, CE	-	-	CSA, UL 508, UL 873, UL 60730-1, BTL, CE
24...240 V \sim / \pm (-10...+10%)	24...240 V \sim / \pm	-	-	-
-	-	-	-	-
Operation: -25...+55 °C Storage: -40...+70 °C	Operation: -25...+55 °C Storage: -40...+70 °C	-	-	Operation: -20...+65 °C Storage: -25...+70 °C
IP20 conforming to EN/IEC 60529	IP65 conforming to EN/IEC 60529 IK05 conforming to EN/IEC 50102	-	-	IP20 conforming to EN/IEC 60529
ZBRN1 (1)	ZBRN2 (1)	ZBRA1 (1)	ZBRA2 (1)	ZBRCETH (1)
12	13			

Limit switches

XCMW range

Wireless and batteryless limit switches

Miniature format

XCMW range

Telemecanique Sensors has expanded its offer of wireless products with the XCMW range of limit switches based on an automatic radio wave generator system.

This range includes transmitters and receivers that communicate via 2.4 GHz radio transmission.

There is no need to use batteries, as the radio pulse is emitted while the actuator moves.

Operation is therefore one-way towards the receiver.

The XCMW offer can be used to determine the position of an item or part of a machine remotely, without a wired connection. The transmitter is equipped with a "dynamo" generator that converts the mechanical energy produced by the actuator movement to electrical energy.

A radio-encoded message (2.4 GHz ZigBee protocol) is then sent, by a single pulse, to one or more receivers located several dozen meters away.

The system is self-powered, which means no batteries are needed.

Each transmitter has a unique identification code, which enables optimal management of each one. To incorporate this code, a simple teach sequence must be performed on the receiver using the two buttons on the front face.

Thanks to this technology, the industrial applications field has diversified and now meets the requirements of machine manufacturers in terms of flexibility and modularity. It is the ideal product for confirming the position of a part remotely after a manual operation by an operator (1).

XCMW wireless limit switches are therefore particularly suitable (2) for:

- automatic doors
- expandable conveyors
- wheel chocks for trucks
- rotary machines
- turntables

Note: Receivers can be actuated by XCMW limit switches or ZB•RTA• Schneider Electric pushbuttons.

Simplified installation

- > Faster installation: no wiring between the limit switch and the receiver
- > No configuration necessary, thanks to the Plug and Play ready-to-use solution
- > Freedom of movement around the machine or process in order to detect parts that are moving or difficult to access

Reduced maintenance

- > No battery maintenance required
- > Optimum availability of control functions
- > Minimal post-installation maintenance (no need for periodic retightening of contact terminal connections, no cables to be replaced or repaired)



(1) An operating speed above 10 mm/s is recommended.

(2) XCMW wireless and batteryless limit switches are not suitable for hoisting applications or hazardous machinery.

For these applications and machines, the XC Standard range of cabled switches is ideal. Please contact our Customer Care Center.

Wave generated automatically without a battery



XCMW

Wireless offer:
one-way **pulsed** transmission

Multi-sensor transmitter

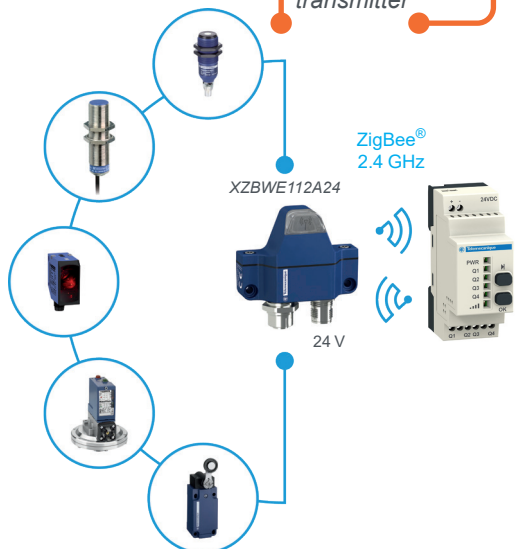

"Less-wire" offer:
Two-way **continuous** transmission
With the XZBWE112A24 multi-sensor transmitter, our "less-wire" offer allows continuous communication between the transmitter and the receiver (see page 13).

+ Wireless and batteryless switches for simplified installation

Limit switches

XCMW range

Wireless and batteryless limit switches

Miniature format

The miniature format of the XCMW limit switch allows easy integration in machines

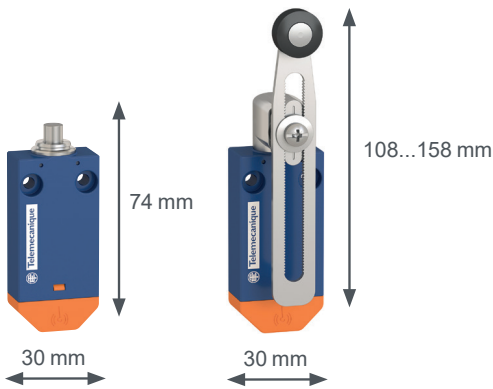

Miniature format

One of the smallest formats on the market

> Ideal for automatic doors, the limit switch can be easily installed in aluminum profiles.

Improved performance

A relay antenna increases the signal range

> Range of 300 meters, in free field, using an external relay antenna
> Range of 100 meters in free field

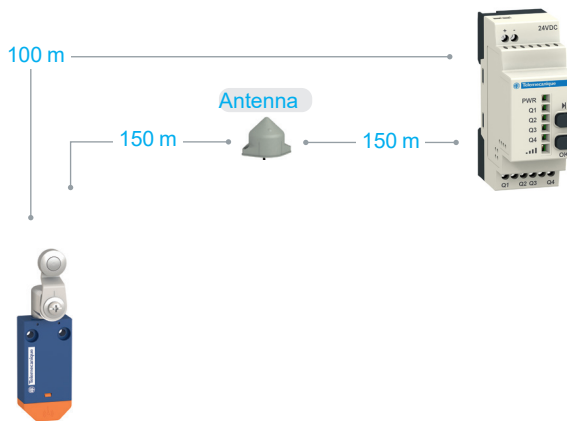

Open protocols for easy integration

Large I/O capacity

> The offer includes a receiver that can manage up to 60 transmitters.
The signals received are converted to communication protocols.
> The proposed access points can be connected to an automation platform by Modbus RS485 serial link or Modbus/TCP protocol.

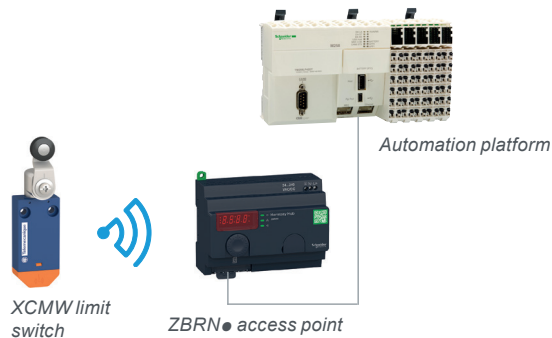

Limit switches

XCMW range

Wireless and batteryless limit switches

Miniature format



XCMW110



XCMW102



XCMW115



XCMW116



XCMW145

Description

“Components” offer

The XCMW range comprises:

- **9 wireless and batteryless limit switches** consisting of a plastic body and an actuator head taken from the existing **XCMN** and **XCMD** ranges.

- **3 receivers** that can be programmed using buttons on the front face:

- with 2 contact relay outputs, 24...240 V ~/---
- with 2 or 4 PNP transistor outputs, 24 V ---

- **2 access points** that provide open network connectivity by operating as an intermediate device between the transmitter and the PLC. The access point receives radio signals from the XCMW limit switches and converts them to communication protocols.

The access point is connected to the PLC using:

- an Ethernet Modbus/TCP communication protocol for **ZBRN1**
- Modbus RS485 serial link communication for **ZBRN2**

- **Accessories:**

- 1 active relay antenna to boost the signal when the receiver is in a metal enclosure or to get round obstacles in the case of a complex installation
- 1 external antenna for **ZBRN1** or **ZBRN2** access points to increase the range
- 1 communication module for Ethernet Modbus/TCP network

“Ready-to-use pack” offer

To make it easier to install XCMW limit switches, ready-to-use packs are also available. The transmitter (limit switch) and receiver are factory-paired.

Each pack contains:

- a limit switch
 - one version with metal end plunger
 - one version with plastic roller lever
 - one version with round plastic rod lever, Ø 6 mm
- a receiver with 2 time delay relay outputs

Limit switches

XCMW range

Wireless and batteryless limit switches

Miniature format

Transmission system for sensors

Characteristics of XCMW1●● limit switches

Environmental characteristics

Conformity to standards	Products	CE, EN/IEC 60947-5-1, UL 508, CSA C22-2 No. 14, CCC
	Machine assemblies	EN/IEC 60204-1
Product certifications		UL, CSA, CCC, UKCA
Protective treatment	Version	Standard: "TC"; Special: "TH"
Ambient air temperature	For operation	-25...+70 °C
	For storage	-40...+70 °C
Vibration resistance	Conforming to EN/IEC 60068-2-6	25 gn (10...500 Hz)
Shock resistance	Conforming to EN/IEC 60068-2-27	40 gn (11 ms)
Protection against electric shock	Conforming to EN/IEC 61140	Class II
Degree of protection	Conforming to EN/IEC 60529	IP65
	Conforming to EN 62262	IK04
Materials		Plastic body, metal head

Characteristics of XZBWR2STT24 receiver

Ambient air temperature	For operation	-20...+55 °C
	For storage	-40...+70 °C
Power supply		24 V \pm 100 mA max.
Outputs		2 + 2 PNP (200 mA each output)
Degree of protection	Conforming to EN/IEC 60529	IP20
Display		1 LED for each output, 1 LED for the power supply, 1 LED for the signal current

Characteristics of XZBWE112A24 radio transmitter

Radio range in free field		100 m
Typical radio range in industrial environment		25 m
Ambient air temperature	For operation	-25...+55 °C
	For storage	-40...+70 °C
Power supply (transmitter only)		24 V - 15%
Output power supply for sensor or limit switch		24 V - 15%/+20% - 100 mA max. (no overload protection)
Start-up time		< 0.4 s
Response time		30 ms
Input frequency		< 0.5 Hz
Degree of protection	Conforming to EN/IEC 60529	IP67
Display		1 green or orange LED depending on the mode

Limit switches

XCMW range
Wireless and batteryless limit switches
Miniature format

Type of head	Plunger (fixing by the body)	Rotary (fixing by the body)					
--------------	------------------------------	-----------------------------	--	--	--	--	--



Type of operator	Metal end plunger	Steel roller plunger	Steel or thermoplastic roller lever (1) (2)	Variable length steel or thermoplastic roller lever (1) (2)	Thermoplastic roller lever, Ø 50 mm (1) (2)	Variable length thermoplastic roller lever, Ø 50 mm (1) (2)	Round thermoplastic rod lever, Ø 6 mm (2) (3) (4)
------------------	-------------------	----------------------	---------------------------------------------	-------------------------------------------------------------	---------------------------------------------	-------------------------------------------------------------	---------------------------------------------------

References

	XCMW110	XCMW102	XCMW115 (thermoplastic) XCMW116 (steel)	XCMW145 (thermoplastic) XCMW146 (steel)	XCMW139	XCMW149	XCMW159

Weight (kg)	0.040	0.045	0.085 0.090	0.095 0.100	0.100	0.110	0.080
-------------	-------	-------	----------------	----------------	-------	-------	-------

Receiver output status	<input checked="" type="checkbox"/> Closed <input type="checkbox"/> Open		(A) = Cam displacement				
------------------------	-----------------------------------------------------------------------------	--	------------------------	--	--	--	--

Characteristics

Switch actuation	On end	By 30° cam					By any moving part
Type of actuation							
Maximum actuation speed	0.5 m/s	1.5 m/s					1 m/s
Mechanical durability (in millions of operating cycles)	25	15	20				
Minimum force or torque	For actuation	15 N	12 N	0.10 N.m			
	For positive opening	30 N	20 N	0.15 N.m	0.15 N.m	-	-

(1) Adjustable throughout 360° in 5° steps, or in 90° steps by reversing the notched washer.
 (2) A limit switch without a lever can be ordered: reference XCMW101.
 (3) Adjustable throughout 360° in 5° steps, or in 45° steps by reversing the lever mounting.
 (4) Value taken with actuation by moving part 100 mm from the fixing.

Limit switches

XCMW range

Wireless and batteryless limit switches

Miniature format

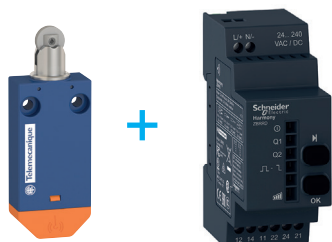

XCMWD02



XCMWD15



XCMWD59



ZBRRD



XZBWR2STT24

References (continued)

Ready-to-use packs

Composition	Reference	Weight kg
<ul style="list-style-type: none"> 1 limit switch with steel roller plunger XCMW102 1 receiver with 2 relay outputs ZBRRD (1) 	XCMWD02	0.176
<ul style="list-style-type: none"> 1 limit switch with thermoplastic roller lever XCMW115 1 receiver with 2 relay outputs ZBRRD (1) 	XCMWD15	0.212
<ul style="list-style-type: none"> 1 limit switch with round thermoplastic rod lever, Ø 6 mm XCMW159 1 receiver with 2 relay outputs ZBRRD (1) 	XCMWD59	0.170

Note: The transmitter (limit switch) and receiver are factory-paired.

Receivers

Configurable receivers are equipped with:

- 2 buttons (teach and parameter setting)
- 6 LED indicators (power ON, function modes, output status, and signal strength)

Number and type of outputs	Power supply	Number of transmitters	Reference	Weight kg
4 PNP outputs 200 mA/24 V	24 V ---	32	ZBRRC (1)	0.130
2 time delay relay outputs, 3A	24...240 V ~ / ---	32	ZBRRD (1)	0.130
2 PNP outputs 200 mA/24 V	24 V ---	2	XZBWR2STT24 (2)	0.130

(1) Schneider Electric product, also compatible with ZB•RTA• wireless pushbuttons (with software version V2.0 or above).

(2) Also compatible with ZB•RTA• wireless pushbuttons and the XZBWE112A24 wireless "multi-sensor" transmitter (with software version V1.0 or above).

Limit switches

XCMW range

Accessories for wireless and batteryless limit switches

Network access points

Description

Standard access point with communication module

The **ZBRN1** access point has an empty slot for the **ZBRCETH** communication module to support the Modbus/TCP protocol.

This communication module has two standard Ethernet RJ45 connectors that provide connectivity for daisy chain operation and daisy chain loop operation (when used with Schneider Electric ConneXium Ethernet switches) and thus avoids the use of an external hub or switch.

Access point for Modbus serial link protocol

The **ZBRN2** access point has two embedded RS485 connectors that avoid the use of an external hub for an RS485 serial link connection. The supported data rates are 1200, 2400, 4800, 9200, 9600, 38,400, and 115,200 bps.

References

Access points

Description	Data function	Output type	Receiver voltage	Reference	Weight
			V		kg
Configurable access points equipped with: - 7-segment display - jog dial - 8 LED indicators (power ON, function modes, communication status, signal strength)	Set/Reset	2 RS485 connectors that provide Modbus RS485 serial link connectivity	24...240 ~/-	ZBRN2 (1)	0.270
- external antenna connector and protective cap - for 60 transmitters max.	Set/Reset	1 slot for ZBRCETH communication module (to be ordered separately)	24...240 ~/-	ZBRN1 (1)	0.270

(1) Schneider Electric product, also compatible with **ZB•RTA•** wireless pushbuttons (with software version V1.5 or above).



ZBRN1



ZBRN2

Limit switches

XCMW range

Accessories



ZBRCETH



ZBRA2



ZBRA1



XZBWE112A24

References

Modbus/TCP network communication module

Description	Communication port	Reference	Weight kg
Communication module for ZBRN1 access point Modbus/TCP protocol with embedded web pages, available in 5 languages, for configuration, monitoring, and diagnostics	2 RJ45 connectors for daisy chain or daisy chain loop operation	ZBRCETH (1)	0.044

Relay antenna

Use	Description	Reference	Weight kg
Increases the distance between the limit switches and the receivers	24...240 V ~/- 5 m cable 1 power ON LED 2 reception/ transmission LEDs	ZBRA1 (2)	0.200

External antenna

Use	Description	Reference	Weight kg
Connected to ZBRN1 or ZBRN2 access point to increase transmission distance	2 m cable 1 RF connector	ZBRA2 (1)	0.040

Multi-sensor radio transmitter for "less-wire" solution

This remote connection system, compatible with any sensor or limit switch, is used to reduce costs by using less wiring for all kinds of application.

- For radio transmission to a 24 V sensor or limit switch
- Compatible with a PNP or NPN sensor or limit switch
- ZigBee Green Power 2.405 GHz communication protocol

Description	Reference	Weight kg
1x 5-pin M12 female connector (sensor) 1x 4-pin M12 male connector (power supply) 2 LED indicators (sensor output and data exchange)	XZBWE112A24	0.051

(1) Schneider Electric product.

(2) Schneider Electric product, also compatible with **ZB•RTA•** wireless pushbuttons.

Limit switches

XCMW range

Wireless and batteryless limit switches

Miniature format

Dimensions

XCMW110

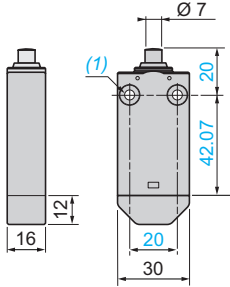

XCMW102

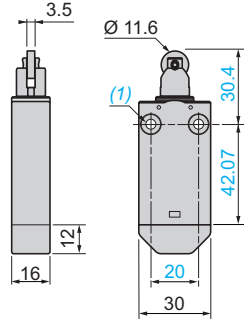

XCMW115, XCMW116

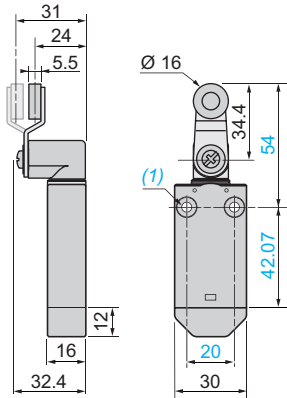

XCMW145, XCMW146

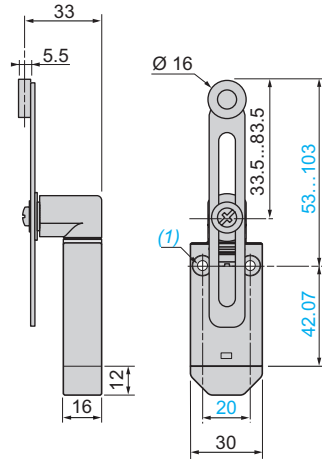

XCMW159

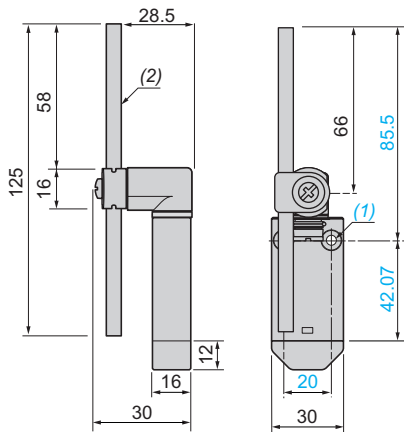

(1) 2 fixing holes Ø 4.2 mm

(2) Rod Ø 6 mm

Limit switches

XCMW range

Wireless and batteryless limit switches

Miniature format

Transmission system for sensors

Dimensions (continued)

XCMW139

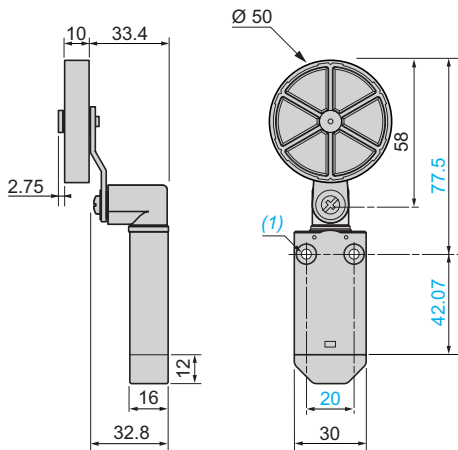

XCMW149

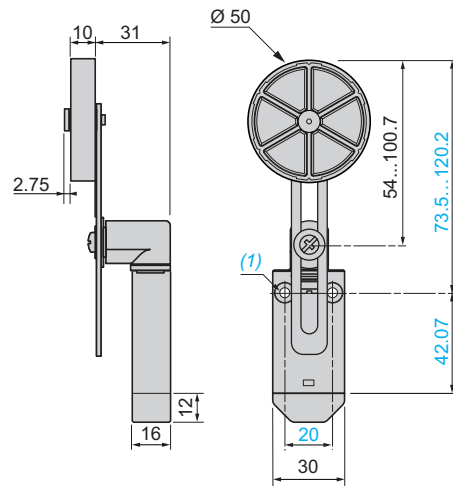

XZBWR2STT24

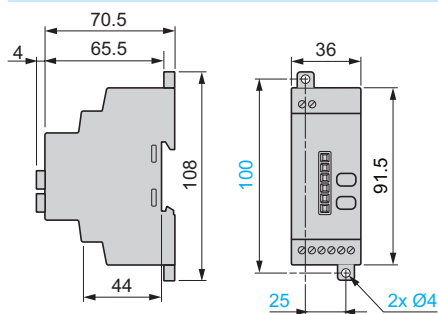

XZBWE112A24

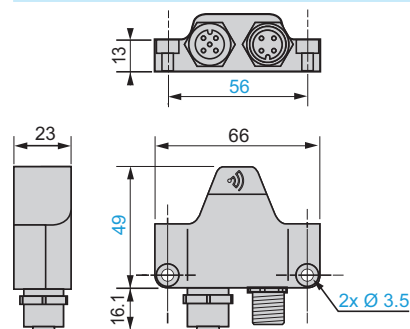

Connections

XZBWR2STT24

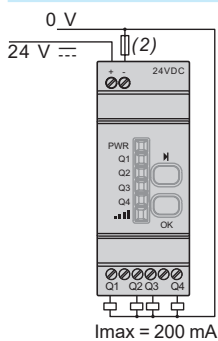

XZBWE112A24

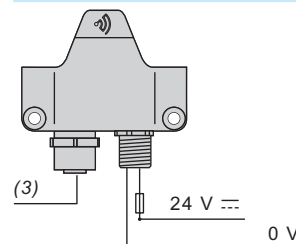

(1) 2 fixing holes Ø 4.2 mm

(2) 1A fast-acting Bussman® fuse, reference GMA - 1A, 250 V

(3) M12 connector for sensor

X	
XCMW102	10
XCMW110	10
XCMW115	10
XCMW116	10
XCMW139	10
XCMW145	10
XCMW146	10
XCMW149	10
XCMW159	10
XCMWD02	11
XCMWD15	11
XCMWD59	11
XZBWE112A24	13
XZBWR2STT24	11

N	
ZBRA1	13
ZBRA2	13
ZBRCETH	13
ZBRN1	12
ZBRN2	12
ZBRRC	11
ZBRRD	11

www.tesensors.com

The information provided in this catalogue contains description of products sold by TMSS France, its subsidiaries and other affiliated companies ("Offer") with technical specifications and technical characteristics of the performance of the corresponding Offer.

The content of this document is subject to revision at any time without notice due to continued progress in methodology, design and manufacturing.

To the extent permitted by applicable law, no responsibility or liability is assumed by TMSS France, its subsidiaries and other affiliated companies for any type of damage arising out of or in connexion with (a) informational content of this catalogue not conforming with or exceeding the technical specifications, or (b) any error contained in this catalogue, or (c) any use, decision, act or omission made or taken on the basis of or in reliance on any information contained or referred to in this catalogue.

NEITHER TMSS FRANCE, ITS SUBSIDIARIES, NOR ITS OTHER AFFILIATES, AS THE CASE MAYBE, MAKE NO WARRANTY OR REPRESENTATION OF ANY KIND, WHETHER EXPRESS OR IMPLIED, AS TO WHETHER THIS CATALOGUE OR ANY INFORMATION CONTAINED THEREIN SUCH AS PRODUCTS WILL MEET REQUIREMENTS, EXPECTATIONS OR PURPOSE OF ANY PERSON MAKING USE THEREOF.

Telemecanique™ Sensors is a trademark of Schneider Electric Industries SAS used under license by TMSS France. Any other brands or trademarks referred to in this catalogue are property of TMSS France or, as the case may be, of its subsidiaries or other affiliated companies. All other brands are trademarks of their respective owners. This catalogue and its content are protected under applicable copyright laws and provided for informative use only.

No part of this catalogue may be reproduced or transmitted in any form or by any means (electronic, mechanical, photocopying, recording, or otherwise), for any purpose, without the prior written permission of TMSS France. Copyright, intellectual, and all other proprietary rights in the content of this catalogue (including but not limited to audio, video, text, and photographs) rests with TMSS France, its subsidiaries, and other affiliated companies or its licensors. All rights in such content not expressly granted herein are reserved. No rights of any kind are licensed or assigned or shall otherwise pass to persons accessing this information.

As standards, specifications and design change from time to time, please ask for confirmation of the information given in this publication.

©2023, TMSS France, All Rights Reserved.

TMSS France
35 rue Joseph Monier 92500
Rueil-Malmaison – France

TES ELECTRIC US, LLC
70 Mechanic Street
Foxboro, MA 02035 - United States of America

September 2023 - V1.0

TESEBRO000036EN