

TeSys[®] U LULC032-033

Modbus

Communication Module

User's Manual

07/2019



Schneider Electric assumes no responsibility for any errors that may appear in this document. If you have any suggestions for improvements or amendments or have found errors in this publication, please notify us.

No part of this document may be reproduced in any form or by any means, electronic or mechanical, including photocopying, without express written permission of Schneider Electric.

All pertinent state, regional, and local safety regulations must be observed when installing and using this product. For reasons of safety and to help ensure compliance with documented system data, only the manufacturer should perform repairs to components.

When devices are used for applications with technical safety requirements, the relevant instructions must be followed.

Failure to use Schneider Electric software or approved software with our hardware products may result in injury, harm, or improper operating results.

Failure to observe this information can result in injury or equipment damage.

© 2019 Schneider Electric. All rights reserved.

Table of Contents



| | | |
|------------------|---|-----------|
| | Safety Information | 5 |
| | About the Book | 7 |
| Part I | Hardware Implementation | 9 |
| Chapter 1 | Installing the LULC032-033 Modbus Module | 11 |
| | Safety Instructions | 12 |
| | Presentation of the LULC032-033 Modbus Communication Module | 13 |
| | Description of the Module and Installation | 15 |
| | Electrical Connection | 18 |
| | Connection to the RS485 Bus | 22 |
| Chapter 2 | Technical Characteristics | 29 |
| | Conditions of Use and Technical Characteristics | 30 |
| | Replacing an LULC031 Module with an LULC032-033 Module | 32 |
| Part II | Software Implementation | 35 |
| Chapter 3 | Starting up the Module via the Registers | 37 |
| | General Information on Start-up via the Registers | 38 |
| | Data-Exchange Format | 39 |
| | Factory Configuration | 41 |
| | Customizing Your Configuration | 42 |
| | Modbus Requests and Programming Examples | 47 |
| | Use of the Main Registers for Simplified Management | 48 |
| Chapter 4 | Fault and Warning Management | 49 |
| | Displaying Faults | 50 |
| | Application Faults | 51 |
| | Warnings - Loss of Communication | 52 |
| | Internal Faults | 53 |
| Chapter 5 | Configuration of Predefined Functions | 55 |
| | Description of Reflex Stop Functions | 56 |
| | Use of Reflex1 and Reflex2 | 58 |
| Index | | 61 |



Important Information

NOTICE

Read these instructions carefully, and look at the equipment to become familiar with the device before trying to install, operate, or maintain it. The following special messages may appear throughout this documentation or on the equipment to warn of potential hazards or to call attention to information that clarifies or simplifies a procedure.



The addition of this symbol to a Danger or Warning safety label indicates that an electrical hazard exists, which will result in personal injury if the instructions are not followed.



This is the safety alert symbol. It is used to alert you to potential personal injury hazards. Obey all safety messages that follow this symbol to avoid possible injury or death.

DANGER

DANGER indicates an imminently hazardous situation which, if not avoided, **will result in** death or serious injury.

WARNING

WARNING indicates a potentially hazardous situation which, if not avoided, **can result in** death or serious injury.

CAUTION

CAUTION indicates a potentially hazardous situation which, if not avoided, **can result in** minor or moderate injury.

CAUTION

CAUTION, used without the safety alert symbol, indicates a potentially hazardous situation which, if not avoided, **can result in** equipment damage.

PLEASE NOTE

Electrical equipment should be installed, operated, serviced, and maintained only by qualified personnel. No responsibility is assumed by Schneider Electric for any consequences arising out of the use of this material.

A qualified person is one who has skills and knowledge related to the construction and operation of electrical equipment and the installation, and has received safety training to recognize and avoid the hazards involved.

About the Book



At a Glance

Document Scope

This Manual describes the implementation, functions and operation of the LULC032-033 Modbus communication module.

Area of application: mainly control system applications in the Industry and Building sectors.

Validity Note

Firmware version compatibility:

| Product versions | | | | |
|------------------|---------|-------|--------|--------|
| | LULC03• | LUTM | LUCM | LUCMT |
| LULC032 | V1.1 | V1.1 | --- | V2.06 |
| | V1.2 | V1.2* | --- | V2.10* |
| | V1.3 | V1.2* | --- | V2.11* |
| LULC033 | V2.2 | V1.2* | V1.10* | V2.11* |

* and later versions.

Related Documents

| Title of Documentation | Reference Number |
|---|----------------------------|
| LULC033 Modbus Module - Instruction Sheet | 1743239 |
| LU9GC3 Modbus Tap Module - Instruction Sheet | 1638860 |
| TeSys U Communication Variables - User's Manual | 1744082 |
| LU•B/LU•S• TeSys U Starters - Instruction Sheet | 1629984 |
| LUTM• TeSys U Controller - User's Manual | 1743233 |
| LUTM• TeSys U Controller - Instruction Sheet | 1743236 |
| LUCM/LUCMT Multifunction Control Units - User's Manual | 1743237 |
| LUCM/LUCMT/LUCBT/LUCDT Control Units - Instruction Sheet | AAV40504 |
| LUCA/LUCB/LUCC/LUCD Control Units - Instruction Sheet | AAV40503 |
| Electromagnetic Compatibility - Practical Installation Guidelines | DEG999 |
| Modbus Over Serial Line, Specification & Implementation Guide | Modbus_over_serial_line_V1 |

You can download these technical publications and other technical information from our website at <https://www.schneider-electric.com/en/download>

Part I

Hardware Implementation

Introduction

This section describes the LULC032-033 Modbus communication module installation and technical characteristics.

What Is in This Part?

This part contains the following chapters:

| Chapter | Chapter Name | Page |
|---------|--|------|
| 1 | Installing the LULC032-033 Modbus Module | 11 |
| 2 | Technical Characteristics | 29 |

Chapter 1

Installing the LULC032-033 Modbus Module

Introduction

This chapter introduces the LULC032-033 Modbus communication module and describes the various steps involved in the physical installation of the product.

What Is in This Chapter?

This chapter contains the following topics:

| Topic | Page |
|---|------|
| Safety Instructions | 12 |
| Presentation of the LULC032-033 Modbus Communication Module | 13 |
| Description of the Module and Installation | 15 |
| Electrical Connection | 18 |
| Connection to the RS485 Bus | 22 |

Safety Instructions

General Instructions

CAUTION

HAZARDOUS OPERATION

These devices must be installed, configured and used by qualified staff only.

Users must follow all current instructions, standards and regulations.

Check the function settings before starting the motor.

Do not downgrade or modify these devices.

Failure to follow these instructions can result in injury or equipment damage.

CAUTION

PRECAUTIONS WHEN USING COMMUNICATION VARIABLES

Only use the serial link for transmitting data that is not critical to the application.

There is some delay in the transmission of data relating to motor-starter states and load-current values.

This data must not therefore be used in the management of safety devices and emergency stops.

Data such as Forward, Reverse and Stop must not be used in safety and emergency-stop circuits.

Failure to follow these instructions can result in injury or equipment damage.

Presentation of the LULC032-033 Modbus Communication Module

Receiving the Product

On opening the box containing the LULC032-033 Modbus communication module, you should find the following items:

- An Instruction Sheet (IS), providing brief pictorial information about the standard installation of the module
- An LULC032-033 Modbus communication module with connectors.

NOTE: Check that you actually have all the items described above. Make sure that the Quick Reference Guide is included, along with the correctly inserted connectors.

Functions offered

The communication module is used to control a motor-starter remotely, via Modbus, from:

| | | LULC032 | LULC033 |
|----------------------------|--------------|---------|---------|
| TeSys U starter-controller | LUB**/LU2B** | | √ |
| TeSys U starter | LUS**/LU2S** | | √ |
| TeSys U controller | LUTM** | √ | √ |

NOTE: Modbus LULC032 communication modules should be used exclusively with LUTM10BL or LUTM20BL controllers.

Using the communication module, you can:

- Read the motor-starter states
- Control the motor-starter (reversing or non-reversing)
- Adjust the protection functions
- Read the data processed in the advanced and multifunction control units
- Read the state of the I/O (controller base)

⚠ DANGER

CONTROL VOLTAGE

The LULC032 Modbus communication module must only be used with 24 V control units (LUC***BL). ---.

Failure to follow these instructions will result in death or serious injury.

NOTE: For information on the Modbus protocol, please refer to the following website: www.Modbus.org.

Data Available

The available protection and control data depend on the control unit with which the Modbus communication module is used.

There are 3 types of control unit:

- Standard (reference LUCA)
- Advanced (references LUCB/C/D, LUCBT/DT)
- Multifunction (references LUCM/MT)

The table below can be used to check the data and commands you can access with each type of control unit:

| Data - Commands | Control unit | | |
|--|-----------------|-------------------------------|-------------------------|
| | Standard (LUCA) | Advanced (LUCB/C/D, LUCBT/DT) | Multifunction (LUCM/MT) |
| Start and stop commands | √ | √ | √ |
| Status (ready, running, fault condition) | √ | √ | √ |

| Data - Commands | Control unit | | |
|---|-----------------|-------------------------------|-------------------------|
| | Standard (LUCA) | Advanced (LUCB/C/D, LUCBT/DT) | Multifunction (LUCM/MT) |
| Warning | | √ | √ |
| Automatic reset and remote reset via the bus | | √ | √ |
| Indication of the motor load | | √ | √ |
| Differentiation of faults | | √ | √ |
| Remote parameter setting and viewing of all functions | | | √ |
| 'Log' function | | | √ |
| 'Monitoring' function | | | √ |

Description of the Module and Installation

Diagram of the Module

Connectors and indicator lights (LEDs) on the LULC032-033 Modbus communication module :

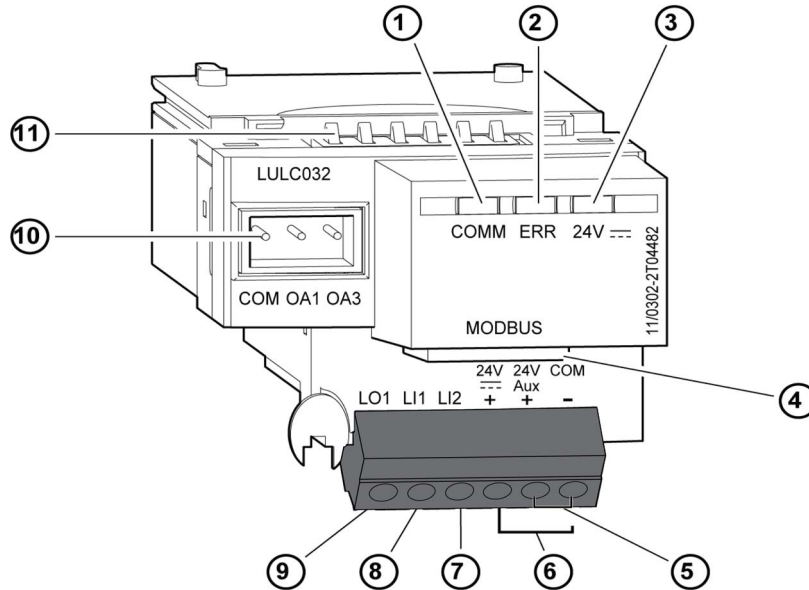

NOTE: The pinout differs from that on the LULC031 Modbus communication module.

- 1 Green "COMM" Modbus communication status LED.
- 2 Red "ERR" Modbus communication module fault indication LED.
- 3 Green "24V ---" LED indicating voltage presence at outputs OA1, OA3, LO1.
- 4 RJ45 connector for the Modbus RS485 link.
- 5 Connection of the module power supply.
- 6 Connection of the 24 V --- power supply for outputs OA1, OA3, LO1.
- 7 Discrete input 2.
- 8 Discrete input 1.
- 9 Discrete output 1, assignable depending on the configuration register (685 LSB).
- 10 24 V --- prewired coil connector for the power base.
 - The assignment of OA1 depends on the configuration register (686 LSB).
 - The assignment of OA3 depends on the configuration register (686 MSB).
- 11 Connector for communication with the advanced or multifunction control unit.

Description of Indicator Lights (LEDs)

Description of the various states of the indicator lights (light-emitting diodes, LEDs) on the LULC032-033 Modbus communication module.

| Light-emitting diodes (LEDs) | | | Meaning |
|---|--|---------------------|--|
| Green "COMM" LED | Red "ERR" LED | Green "24V ---" LED | |
| Flashing (alternately with the "ERR" LED) | Flashing (alternately with the "COMM" LED) | On | Bus parameter initialization in progress |
| Flashing during communication with the Module address | Off | On | Normal operation |
| Off | Off | Off | Faulty: 24 V DC voltage missing on the 24 V DC terminal. Check the connection between the power supply and the communication module. |
| | On | On | Internal fault on the LULC032-033 <i>Internal Faults</i> , page 53 |
| | Flashing | On | Loss of communication on the Modbus network |

NOTE: During startup, because the default fallback mode is "forced stop", if no communication has previously been established, the red "ERR" LED will flash after one minute (default timeout value).

Addressing Using Switches

The Modbus communication module address is defined by switches located on the underside of the module. Simply turn the module over to access them:

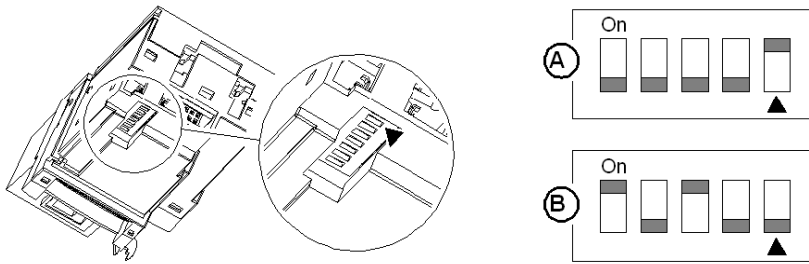

A) Le module est livré d'usine avec l'adresse 1.

B) Exemple de configuration pour l'adresse 20.

The range of accepted values is between 1 and 31.

The address coding is in binary format.

The **least significant bit** is on the right, indicated by ▲.

Address 0 is not taken into account by the module, since it is used by the Master for a broadcast request.

Caution: Address selection differs from that on the LULC031 Modbus communication module.

NOTE: Addressing is only taken into account when the communication module is powered up.

Order of Mounting on a Base

The LULC032 module is installed in a controller base, the LULC033 module is installed in a power base or a controller base (on the underside of the control unit which locks it in position).

To install the module in the power base or controller base:

| Step | Action |
|------|---|
| 1 | Choose the prewired coil connection terminals. |
| 2 | Insert the LULC032-033 Modbus communication module. |
| 3 | Insert the control unit which locks the module. |

The diagram below illustrates these steps. Installation of the LULC032-033 Modbus communication module corresponds to step (2). The numbers indicate both the order of mounting for the components and their location.

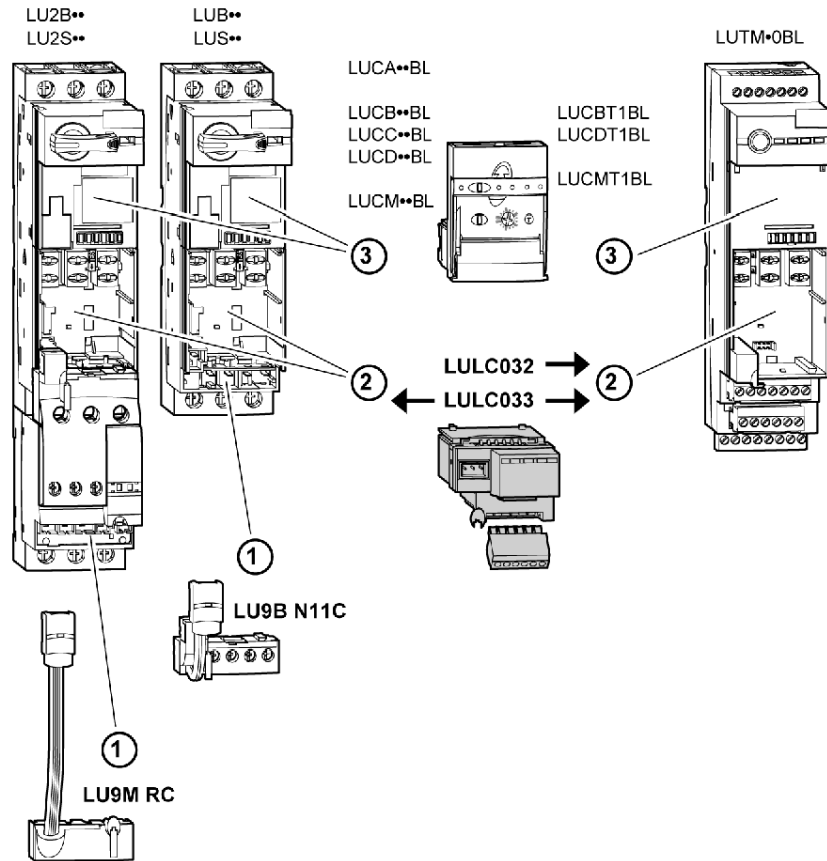

Electrical Connection

24 V $\overline{\text{---}}$ and 24 V Aux Power Supply

Diagram for 24 V $\overline{\text{---}}$ and 24 V Aux power supplies.

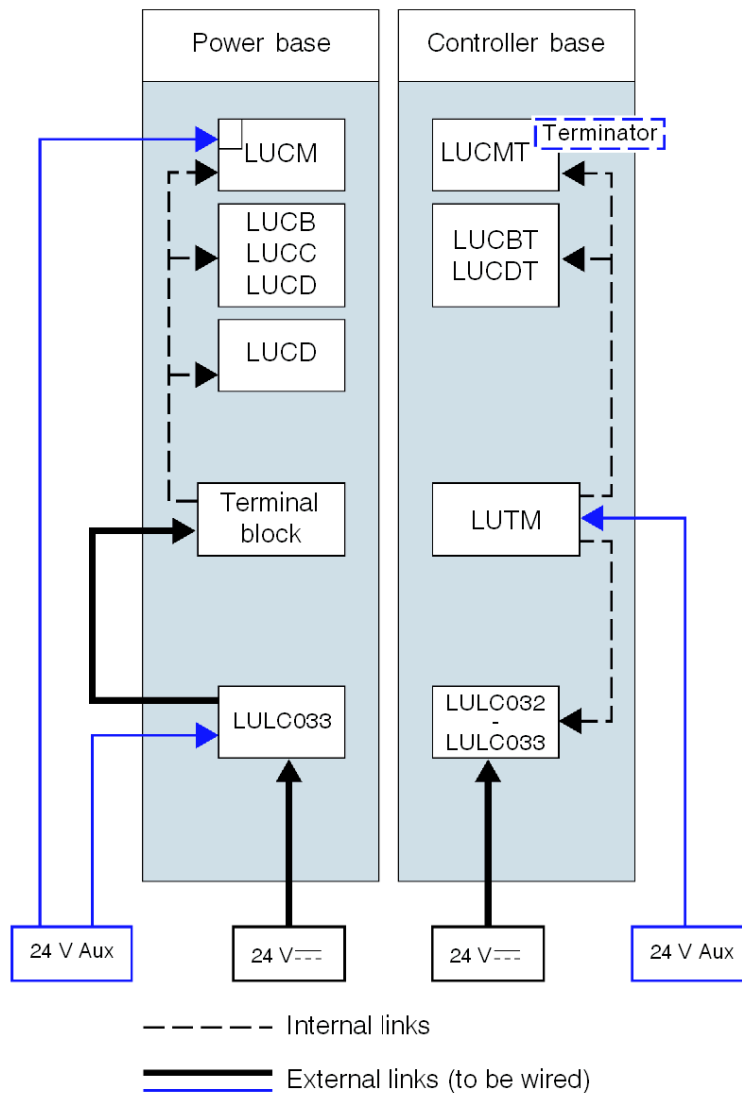

Power-up with an LUCM Multifunction Control Unit

LUCM and Power Base

The power-supply source must be the same for the LULC032-033 Modbus communication module and the LUCM multifunction control unit.

It is essential that the LUCM multifunction control unit and the LULC032-033 Modbus communication module are powered up simultaneously. Indeed, monitoring of the internal dialog between the LUCM and the LULC032-033 will produce two error messages depending on the order in which these objects were powered up.

When the A1-A2 terminals are not yet powered up (24V $\overline{\text{---}}$), there are 3 possible scenarios for powering up the **24V Aux**:

| Powering up the LUCM ... | Powering up the LULC032-033 ... | Comment |
|--------------------------|---------------------------------|--|
| Simultaneously | | Recommended |
| 1st | 2nd | The "M15" fault is displayed. This only occurs when the LULC032-033 Modbus communication module has already been used with the LUCM multifunction control unit. |

| Powering up the LUCM ... | Powering up the LULC032-033 ... | Comment |
|--------------------------|---------------------------------|---|
| 2nd | 1st | The LUCM control unit is identified by the LULC032-033 Modbus communication module when the 24 V Aux for the LULC032-033 Modbus communication module is switched on. If the 24 V Aux for the LUCM control unit is switched on for longer than twice the duration of the timeout (i.e., more than 1 s), the "M101" fault is displayed (register 451, communication module internal faults). |

NOTE: Both these faults are reset by powering down and then powering up the LULC032-033 Modbus communication module (power cycle) and the LUCM control unit.

LUCM and Controller Base

The 24 V \equiv module power supply is provided by the LUTM controller.

Power Supply for the LULC032 and Outputs OA1, OA3 and LO1

In order to operate, the LULC032-033 Modbus communication module must be powered by a 24 V \equiv source:

- With a power base, the LULC033 must be powered by an external source.
- With a controller base, the LULC032 or LULC033 is powered directly.

Power Supply for LUB••/LUS•• /LU2B••/LU2S•• Power Bases

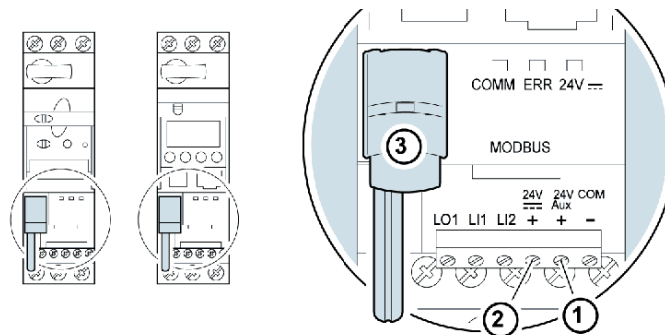

- 1 24 V Aux: Power-supply terminal for the LULC033 Modbus communication module.
- 2 24 V \equiv : Power-supply terminal for outputs OA1 OA3 and LO1.
- 3 Prewired link for connecting outputs OA1 and OA3 to terminals A1/A3/A2 on the starter.

Power Supply for an LUTM Controller Base

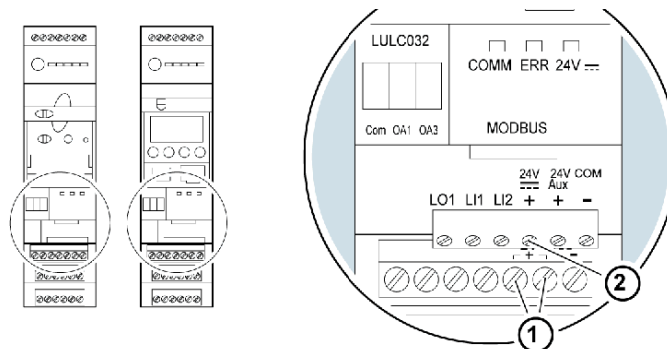

- 1 24 V \equiv : Power-supply terminals for the LUTM and the LULC032-033 Modbus communication module via an internal link.
- 2 The 24 V \equiv power supply for the LULC032-033 Modbus communication module is only required when using outputs OA1, OA3 and LO1.

Power Base: Terminal Power Supply

The user has two options for connecting the **power-base** terminals:

- Power supply via the LULC033 Modbus communication module with a prewired link
- Direct power supply with a wire-to-wire link

Prewired Link

Catalog numbers for the two prewired coils:

| Designation | With a power base | Catalog number |
|---------------|-------------------|----------------|
| Prewired coil | LUB••/LUS•• | LU9B N11C |
| | LU2B••/LU2S•• | LU9M RC |

Illustration for both types of power base:

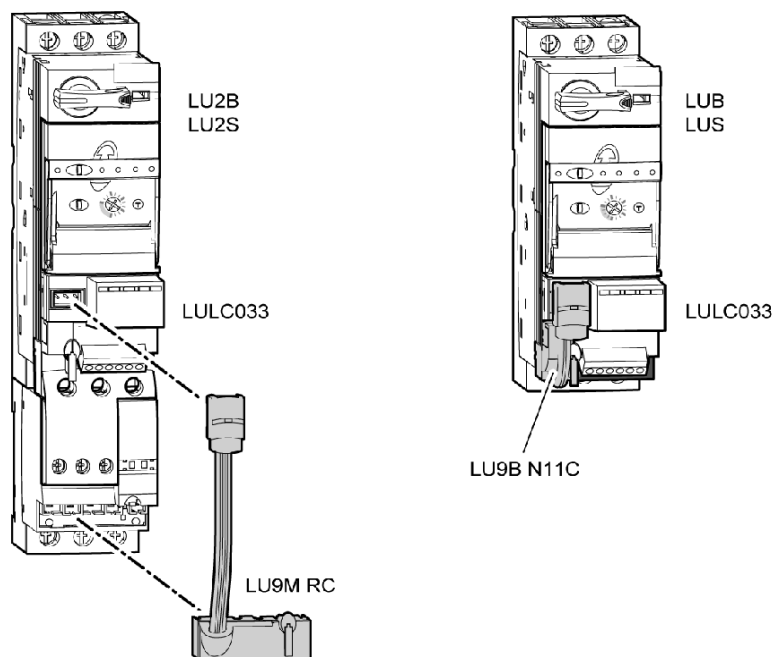

Wire-to-Wire Link (Power Supply to Outputs OA1, OA3 and LO1)

This type of link is compulsory in the case of a reversing starter-controller created from an LU6M reversing unit, for separate assembly.

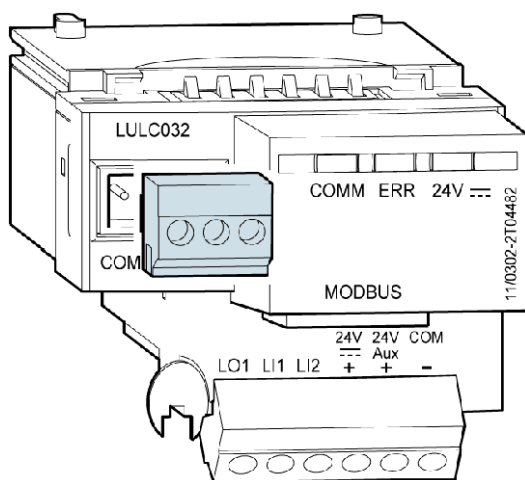

The wire-to-wire link can also be used to insert a local or external stop command, for example.

Connection Capacities of the LULC032-033 Terminals

The table below shows the conductor cross-sections to be used:

| Connection | Type of conductor | Cross-section (min. - max.) | |
|-----------------------------------|---|-------------------------------|-------------------|
| 1 conductor | Solid conductor | 0.14 ... 1 mm ² | AWG 26 ... AWG 18 |
| | Stranded conductor | 0.14 ... 1 mm ² | AWG 26 ... AWG 18 |
| | Stranded conductor with cable end: - Non-insulated - Insulated | 0.25 ... 1 mm ² | AWG 24 ... AWG 18 |
| | | 0.25 ... 0.5 mm ² | AWG 24 ... AWG 20 |
| 2 conductors (same cross-section) | 2 solid conductors | 0.14 ... 0.5 mm ² | AWG 26 ... AWG 20 |
| | 2 stranded conductors | 0.14 ... 0.75 mm ² | AWG 26 ... AWG 20 |
| | 2 stranded conductors with cable end: - Non-insulated - Insulated | 0.25 ... 0.34 mm ² | AWG 24 ... AWG 22 |
| | | 0.50 mm ² | AWG 20 |

| | | |
|--------------------------|---------------|------------------|
| Connectors | 3 and 6 pts | |
| Increment | 3.81 mm | 0.15 in. |
| Tightening torque | 0.2/0.25 N.m. | 28.3/35.4 lb-in. |
| Flat screwdriver | 2.5 mm | 0.10 in. |

Connection to the RS485 Bus

General

There are several ways in which the user can connect the communication module to the RS 485 bus:

- Direct connection to the bus via a VW3A8306TF** T-junction box
- Connection to the bus via a splitter box
- Connection to the bus via SCA type junction boxes

For Interference Protection:

Use the Schneider Electric cable with 2 pairs of shielded twisted conductors (references: TSXCSA100, TSXCSA200, TSXCSA500, VW3A8306TF**).

Keep the Modbus cable away from the power cables (at least 30 cm).

Create crossovers of the Modbus cable and the power cables at right-angles, if necessary.

NOTE: For more information, consult guide TSX DG KBL F: "Electromagnetic Compatibility of Industrial Networks and Fieldbuses".

The RS 485 standard allows variants of some characteristics:

- Polarization
- Line terminator
- Number of slaves
- Length of bus

The new Modbus specification, published in 2002 on the Modbus.org site, defines all these characteristics precisely. All new Schneider Electric devices conform to this specification.

Connection to the Bus via a Tee

The standard diagram corresponds to the Modbus specification published in 2002 on the Modbus.org site (Modbus_over_serial_line_V1.pdf, Nov 2002) and in particular to the 2-wire multidrop serial bus diagram.

The LULC032-033 Modbus communication module conforms to this specification.

The simplified diagram is as follows:

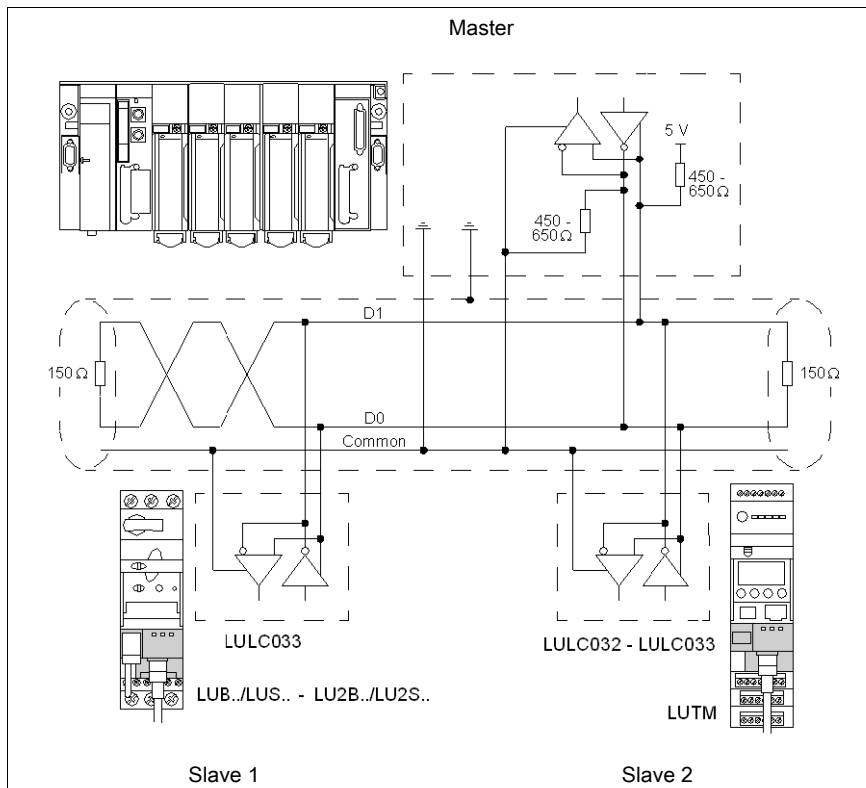

The characteristics for direct connection to the bus are as follows:

| Designation | Description |
|---|--|
| Type of trunk cable | Single shielded twisted pair cable and at least a 3rd conductor |
| Maximum length of bus | 1000 m at 19,200 bps with the Schneider Electric TSX CSA•• cable |
| Maximum number of stations (without repeater) | 32 stations, i.e., 31 slaves |
| Maximum length of tap-offs | <ul style="list-style-type: none"> • 20 m for one tap-off • 40 m divided by the number of tap-offs on the multiple junction box |
| Bus polarization | <ul style="list-style-type: none"> • A 450 to 650 ohm pulldown resistor at the 5 V • A 450 to 650 ohm pulldown resistor at the Common <p>This polarization is recommended for the master. There is no polarization at the RS 485 terminal on the communication module.</p> |
| Line terminator | A 150 ohm resistor +/- 5% |
| Common polarity | Yes (Common), connected to the protective ground in at least one point on the bus |

Connection to the Bus via a Splitter Box

The connection diagram for connection to the bus via a splitter box is as follows:

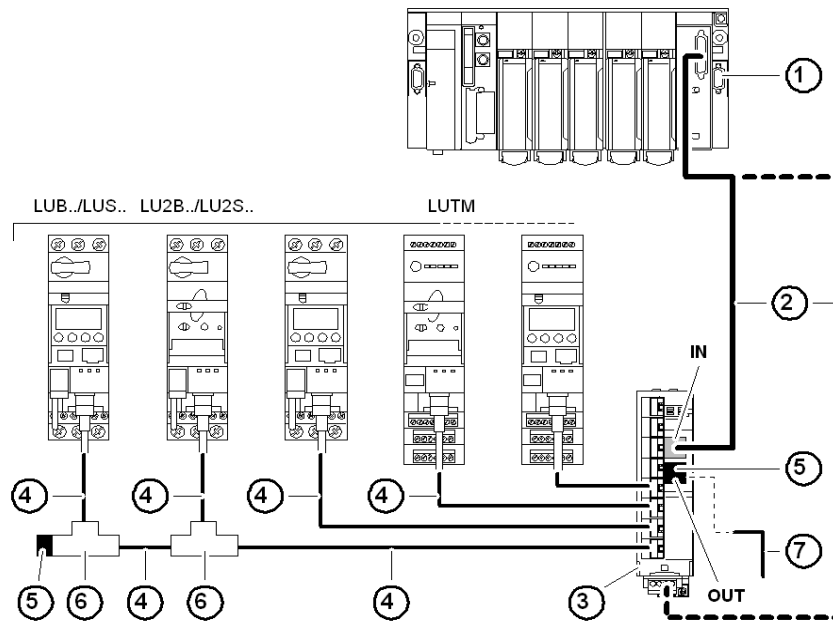

- 1 Master (PLC, PC or communication module)
- 2 Modbus cable depending on the type of master (with polarization integrated on the master side or on another part of the bus)
- 3 Modbus splitter box LU9 GC3
- 4 Modbus drop cables VW3 A8 306 R••
- 5 Line terminators VW3 A8 306 R
- 6 Modbus T-junction boxes VW3A8306TF•• (with cable)
- 7 Modbus cable (to another splitter box) TSX CSA•00 (replaces (5))

NOTE: It is advisable to place a line terminator at each end of the bus to avoid malfunctions on the communication bus. This means that a tee should not have a free connector. It is either connected to a slave or to the master, or there is a line terminator.

NOTE: It is important to connect the bus to the "IN" input (or the screw terminals on the bottom) of the splitter box. Connection to another splitter box is made via the "OUT" output.

Connection Diagrams (PLC <=> Splitter Box)

The two diagrams below describe the connection between:

- Channel 0 of the TSX CSY 21601 module and the LU9 GC3 splitter box using cable TSX SCY CM6030
- PCMCIA card TSX SCP 114 and the LU9 GC3 splitter box using cable TSX SCP CX4030

NOTE: Ensure that the 470 ohm resistors are connected to the 0 V and 5 V polarities correctly.
 Connection between TSX SCY 21601 module (channel 0) and splitter box LU9 GC3 using cable TSX SCY CM6030:

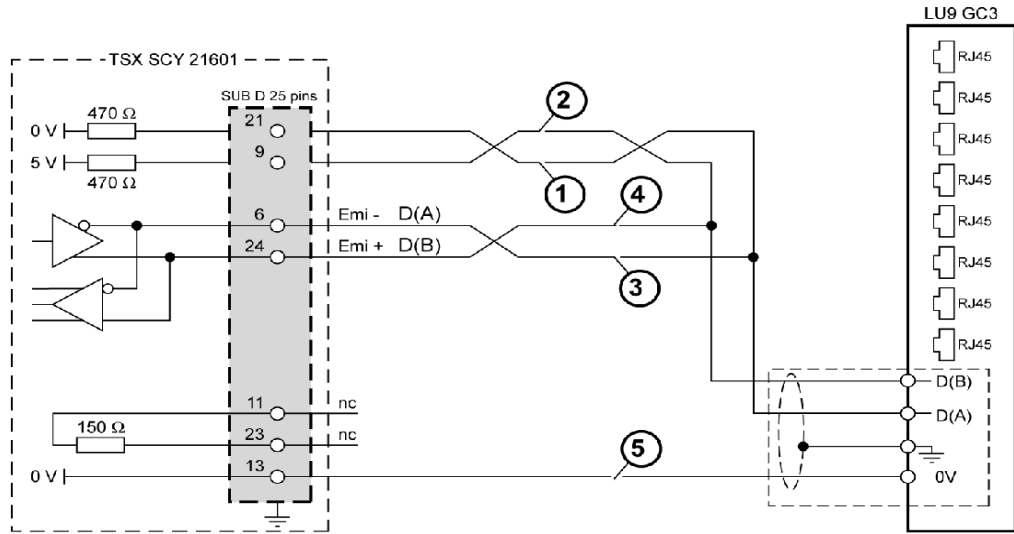

| | | |
|---------------|----------------|---------------|
| 1 Green/White | 3 Orange/White | 5 Brown/White |
| 2 White/Green | 4 White/Orange | |

Connection between PCMCIA/TSX SCP 114 card and LU9 GC3 splitter box using cable TSX SCP CX4030:

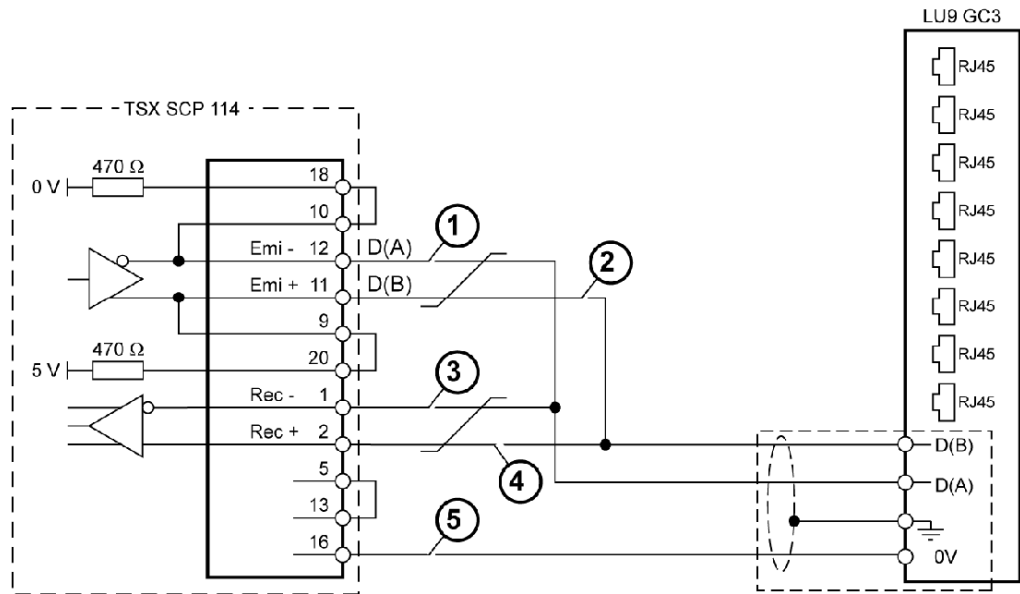

| | | |
|---------------|----------------|---------------|
| 1 Green/White | 3 White/Orange | 5 Brown/White |
| 2 White/Green | 4 Orange/White | |

List of connection accessories:

| Designation | | Catalog number |
|-------------------------|---|-----------------|
| Modbus splitter box | 10 RJ45 connectors and 1 screw terminal | LU9 GC3 |
| Modbus T-junction boxes | With 0.3 m integrated cable | VW3 A8 306 TF03 |
| | With 1 m integrated cable | VW3 A8 306 TF10 |
| Line terminators | For RJ45 connector R = 150 ohms | VW3 A8 306 R |

List of connection cables:

| Designation | Length (meters) | Connectors | Catalog number |
|--|-----------------|-------------------------------------|----------------|
| Cables for Modbus bus | 3 | 1 RJ45 connector and 1 stripped end | VW3 A8 306 D30 |
| | 0,3 | | VW3 A8 306 R03 |
| | 1 | 2 RJ45 connectors | VW3 A8 306 R10 |
| | 3 | | VW3 A8 306 R30 |
| RS 485 double shielded twisted pair cables | 100 | Supplied without connector | TSX CSA 100 |
| | 200 | | TSX CSA 200 |
| | 300 | | TSX CSA 500 |

List of Modbus connection accessories for RJ45 wiring system:

| Type of master | Interface with the master | Description | Catalog number |
|---|---|---|----------------|
| Twido PLC | Mini-DIN RS 485 adaptor or interface module | 3 m cable equipped with a mini-DIN connector and an RJ45 connector | TWD XCA RJ030 |
| | Screw terminal RS 485 adaptor or interface module | 3 m cable equipped with an RJ45 connector and stripped at the other end | VW3 A8 306 D30 |
| TSX Micro PLC | Mini-DIN RS 485 terminal port | 3 m cable equipped with a mini-DIN connector and an RJ45 connector | TWD XCA RJ030 |
| | PCMCIA card (TSX SCP114) | Stripped cable | TSX SCP CX4030 |
| TSX Premium PLC | TSX SCY 11601 or TSX SCY 21601 module (25-pin SUB-D port) | Cable equipped with a 25-pin SUB-D connector and stripped at the other end (for connection to the screw terminals on the LU9GC3 splitter box) | TSX SCY CM6030 |
| | PCMCIA card (TSX SCP114) | Stripped cable | TSX SCP CX4030 |
| Fipio (LUFP1) or Profibus DP (LUFP7) or DeviceNet (LUFP9) gateway | RS 485 RJ45 | Cable, equipped with 2 RJ45 connectors, of the following length: | |
| | | - 0.3 m | VW3 A8 306 R03 |
| | | - 1 m | VW3 A8 306 R10 |
| | | - 3 m | VW3 A8 306 R30 |
| Serial port PC | PC with 9-pin male SUB-D RS 232 serial port | - RS 232/RS 485 converter | TSX SCA 72 |
| | | - 3 m cable equipped with an RJ45 connector and stripped at the other end (for connection to the screw terminals on the LU9GC3 splitter box) | VW3 A8 306 D30 |

Connection to the Bus via SCA Junction Boxes

The connection diagram for connection to the bus via SCA junction boxes is as follows:

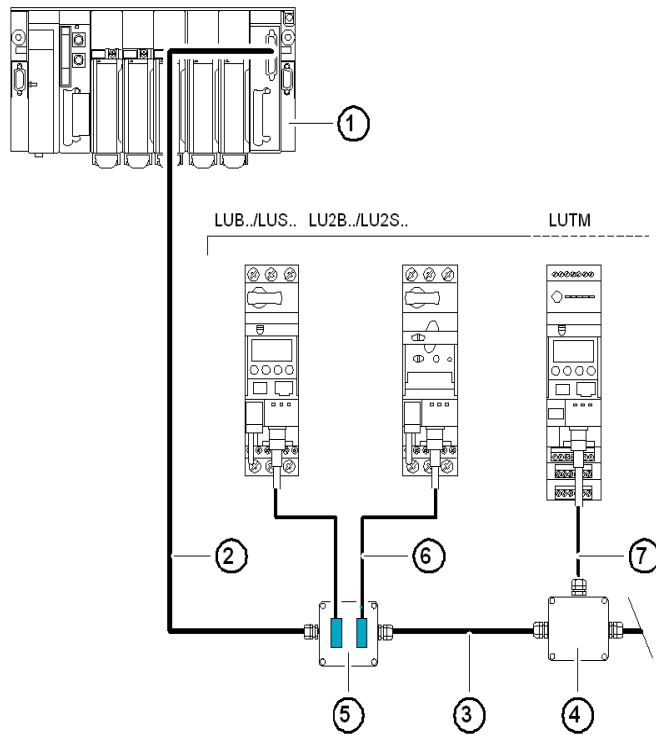

- 1 Master (PLC, PC or communication module).
- 2 Modbus cable depending on the type of master (with polarization integrated on the master side or on another part of the bus).
- 3 Modbus cable TSX CSA•00.
- 4 TSX SCA 50 junction box (without line polarization).
- 5 TSX SCA 62 subscriber port (without line polarization).
- 6 Modbus drop cable VW3 A8 306.
- 7 Modbus drop cable VW3 A8 306 D30.

List of connection accessories:

| Designation | Catalog number |
|---|----------------|
| Junction box 3 screw terminals and RC line terminator, connected with cable VW3 A8 306 D30 | TSX SCA 50 |
| Subscriber port 2 15-pin female SUB-D connectors, 2 screw terminals, and RC line terminator, connected with cable VW3 A8 306 or VW3 A8 306 D30 | TSX SCA 62 |

List of connection cables:

| Designation | Length (meters) | Connectors | Catalog number |
|--|-----------------|---|----------------|
| Cables for Modbus bus | 3 | 1 RJ45 connector and 1 stripped end | VW3 A8 306 D30 |
| | 5 | 1 RJ45 connector and 1 15-pin male SUB-D connector for TSX SCA 62 | VW3 A8 306 |
| RS 485 double shielded twisted pair cables | 100 | Supplied without connector | TSX CSA 100 |
| | 200 | | TSX CSA 200 |
| | 300 | | TSX CSA 300 |

List of Modbus connection accessories for junction box on screw terminals:

| Type of master | Interface with the master | Description | Catalog number |
|--|---|--|--|
| Twido PLC | Screw terminal RS 485 adaptor or interface module | Modbus cable | TSX CSA100 or TSX CSA200 or TSX CSA500 |
| TSX Micro PLC | Mini-DIN RS 485 terminal port | Junction box | TSX P ACC 01 |
| | PCMCIA card (TSX SCP114) | Cable equipped with a special connector and stripped at the other end | TSX SCP CX4030 |
| TSX Premium PLC | TSX SCY 11601 or TSX SCY 21601 module (25-pin SUB-D port) | Cable equipped with a 25-pin SUB-D connector and stripped at the other end | TSX SCY CM6030 |
| | PCMCIA card (TSX SCP114) | Cable equipped with a special connector and stripped at the other end | TSX SCP CX4030 |
| Profibus DP (LA9P307) gateway | RS 485 RJ45 | 3 m cable equipped with an RJ45 connector and stripped at the other end | VW3 A8 306 D30 |
| Fipio (LUF1) or Profibus DP (LUF7) or DeviceNet (LUF9) gateway | RS 485 RJ45 | 3 m cable equipped with an RJ45 connector and stripped at the other end | VW3 A8 306 D30 |
| Serial port PC | PC with 9-pin male SUB-D RS 232 serial port | RS 232/RS 485 converter and Modbus cable | TSX SCA 72 and TSX CSA100 or TSX CSA200 or TSX CSA500 |

RJ45 Connector Pinout

The communication module is connected to the Modbus network with an RJ45 connector in compliance with the following wiring:

| Pin no. | Signal |
|---------|----------------|
| 1 | Do not connect |
| 2 | Do not connect |
| 3 | Do not connect |
| 4 | D(B) or D1 |
| 5 | D(A) or D0 |
| 6 | Do not connect |
| 7 | Do not connect |
| 8 | 0 V.L |

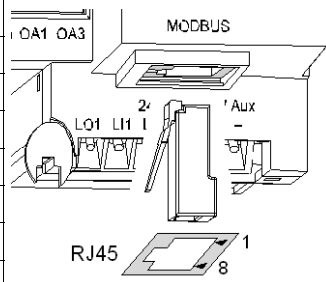

Chapter 2

Technical Characteristics

Introduction

In addition to information about the module's conditions of use and technical characteristics, this chapter provides instructions on how to replace an LULC031 module with an LULC032-033.

What Is in This Chapter?

This chapter contains the following topics:

| Topic | Page |
|--|------|
| Conditions of Use and Technical Characteristics | 30 |
| Replacing an LULC031 Module with an LULC032-033 Module | 32 |

Conditions of Use and Technical Characteristics

The characteristics of the LULC032-033 Modbus communication module are as follows:

- Conditions of Use
- Characteristics of the 24V $\overline{\text{---}}$ and 24V Aux power supply circuits
- Characteristics of the outputs (OA1, OA3 and LO1) and logic inputs (LI1 and LI2)

The communication characteristics (module Modbus port) are also described.

Conditions of Use

The conditions of use for the LULC032-033 Modbus communication module are as follows:

| | | | |
|---|--|----|---------------|
| Certification | UL, CSA | | |
| Conformity to standards | IEC/EN 255-6, UL 508, CSA C22-2 No. 14 | | |
| European Community Directives | CE marking. Satisfies the essential requirements of the low voltage (LV) machinery and electromagnetic compatibility (EMC) directives. | | |
| Temperature of the ambient air around the device | Storage | °C | - 40 ... + 85 |
| | Operation | °C | - 25 ... + 55 |

24V $\overline{\text{---}}$ Power Supply Circuit

The characteristics of the LULC032-033 Modbus communication module 24 V $\overline{\text{---}}$ power supply circuit are as follows:

| | | | |
|----------------------------------|----------------------|----|------------------------------|
| Supply voltage | U_{nominal} | V | 24 V $\overline{\text{---}}$ |
| | Operating range | V | 20 ... 28 |
| Maximum current drawn | | A | 1 |
| Resistance to microbreaks | | ms | 2 |

24 V Aux power-supply circuit

The characteristics of the LULC032-033 Modbus communication module 24 V Aux power supply circuit are as follows:

| | | | |
|----------------------------------|----------------------|----|------------------------------|
| Supply voltage | U_{nominal} | V | 24 V $\overline{\text{---}}$ |
| | Operating range | V | 20 ... 28 |
| Maximum current drawn | | mA | 30 |
| Resistance to microbreaks | | ms | 3 |

Logic Outputs OA1, OA3 and LO1

The characteristics of the LULC032-033 Modbus communication module outputs are as follows:

| | | | |
|---|--------------------------------------|----|---|
| Nominal output values | Voltage | V | 24 V $\overline{\text{---}}$ |
| | Current | mA | 500 |
| Output limit values | Voltage | V | 20 ... 28 |
| | Current | mA | 500 |
| Coincidence factor of the 3 outputs | | % | 66 |
| Output response time (register 704) (Time between the request start bit and the change in the output state) | | ms | 5 (LUCA/B/C/D) 15 (LUCM) 30 (LUCBT/DT) 45 (LUCMT) with stop bit |
| Protection | Against overvoltage | | Yes |
| | Against inversions | | Yes |
| | Against short-circuits and overloads | | Electronic circuit-breaker with automatic reset |
| Number of operating cycles | In millions of operating cycles | | 15 |
| Maximum rate | In operating cycles per hour | | 3600 |

Logic inputs LI1 and LI2

The characteristics of the LULC032-033 Modbus communication module inputs are as follows:

| | | | | |
|-----------------------------|-------------------|---------|----|----------------------------|
| Nominal input values | | Voltage | V | 20 ... 28 (positive logic) |
| | | Current | mA | 7 |
| Input limit values | At state 1 | Voltage | V | 16 |
| | | Current | mA | 6 |
| | At state 0 | Voltage | V | 5 |
| | | Current | mA | 2 |
| Response time | Change to state 1 | | ms | 10 +/- 30 % |
| | Change to state 0 | | ms | 10 +/- 30 % |
| Type of input | | | | Resistive |
| Protection | gl fuse | | A | 1 |

Communication (Modbus Port)

The technical characteristics of the LULC032-033 Modbus communication module Modbus port are as follows:

| Factory configuration | | | |
|---------------------------|--------------------|--|-------|
| Physical interface | 1 | Multidrop RS 485 | |
| Connections | | RJ45 on the front panel | |
| Connection pinout | Schneider standard | D1 (DB) <--> pin 4 D0 (DA) <--> pin 5 OVL <--> pin 8 | |
| Protocol | | Modbus RTU | |
| Physical address | Range | 1 to 31 (address 0 not permitted) | 1 |
| Logical address | Range | 1 to 31 (addresses 32 to 247 not accessible) | |
| Transmission speed | Bps | 1200, 2400, 4800, 9600, 19200 (automatic configuration up to this value) | 19200 |
| Parity | | Even, Odd (1 stop bit). No parity (1 or 2 stop bits) | Even* |
| Turnaround time | ms | 5 (LUCA/B/C/D) 130 (LUCM) 7 (LUCBT/DT) 140 (LUCMT) | |

* All versions (except LULC032 < V1.3: factory-configured with "No parity").

Replacing an LULC031 Module with an LULC032-033 Module

Mounting

The section below presents the LULC031, LULC032 and LULC033 module characteristics in the form of tables.

Mounting modules in different types of base:

| | LULC031 | LULC032 | LULC033 |
|------------------------------------|---------|---------|---------|
| Starter-controller LUB••/LU2B•• | Yes | No | Yes |
| Starter LUS••/LU2S•• | | | |
| Controller LUTM•0BL | No | Yes | Yes |

Combining modules with a control unit:

| LULC031 | LULC032-033 | |
|--------------|---|---|
| LUC••BL only | LUC•••BL only with code date > 0406 (Hardware locating device) | LUC•T1BL only (Hardware locating device) |

Controlling the I/O

Control of outputs OA1 and OA3on LULC031 and LULC032-033:

| LULC031 | LULC032-033 | |
|------------------------------------|------------------------------------|------------------------|
| Starter-controller LUB••/LU2B•• | Starter-controller LUB••/LU2B•• | Controller LUTM•0BL |
| Yes | Yes | Yes |

Control of output LO1 on LULC031 and LULC032-033:

| LULC031 | LULC032-033 | |
|---------|-------------|-----|
| Yes | Yes | Yes |

Reading inputs LI1 and LI2 on LULC031 and LULC032-033:

| LULC031 | LULC032-033 | |
|---------|-------------|-----|
| No | Yes | Yes |

Control of outputs 13 and 23 on LULC031 and LULC032-033:

| LULC031 | LULC032-033 | |
|---------|-------------|-----|
| No | Yes | Yes |

Electrical Connection

The LULC031 and LULC032-033 module terminals look like this:

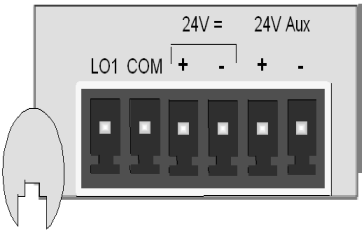
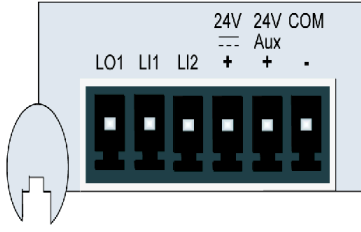
| | |
|----------------------------|---|
| <p>LULC031</p> |  |
| <p>LULC032 LULC033</p> |  <p>2 additional inputs, reduction in the number of commons</p> |

Communication Configuration

The address is selected using switches:

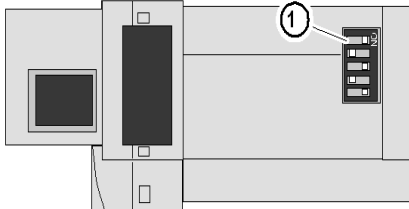
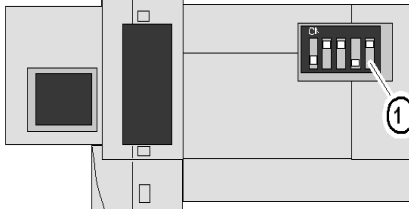
| | |
|----------------------------------|--|
| <p>LULC031</p> |  <p>Speed: 19200 baud - Parity: none/1 stop bit</p> |
| <p>(1) Least significant bit</p> | |
| <p>LULC032 LULC033</p> |  <p>Speed: 19200 baud - Parity: even*/1 stop bit</p> |

* All versions (except LULC032 < V1.3: factory-configured with "No parity").

NOTE: The speed and the parity are calculated automatically by the module. The speed indicated is a maximum value.

Software Configuration

Fallback mode on loss of communication (value of default register):

| | Starter-controller LUB**/LU2B** Starter LUS**/LU2S** | Controller LUTM*0BL |
|----------------|---|--|
| LULC031 | 682 = 0 No detection of loss of communication | - |
| LULC032 | - | 681 = 6000 (timeout = 60 seconds) 682 = 2 (fallback mode = forced stop) |
| LULC033 | 681 = 6000 (timeout = 60 seconds) 682 = 2 (fallback mode = forced stop) | |

Indication of communication losses according to the fallback modes:

| LULC031 | LULC032-033 |
|---|--|
| Forced stop mode: Fault indicated Other modes: Alarm indicated | Any mode: Alarm indicated Acknowledgment via register 703 bit 3 |

Firmware version number:

| LULC031 | LULC032-033 |
|---------------------------------|------------------------------------|
| Register 62 = version no. x 100 | Register 62 = version no. x 10,000 |

NOTE: If you are combining an LULC033 module with a multifunction control unit (LUCM) on a power base, you must reinitialize the LUCM on first use.

Part II

Software Implementation

Introduction

Once the LULC032-033 Modbus communication module hardware implementation phase is complete, the software implementation can begin. It focuses on configuration (the various operating modes), and the function parameters to be set (e.g., protection, current measurement, etc.).

What Is in This Part?

This part contains the following chapters:

| Chapter | Chapter Name | Page |
|---------|--|------|
| 3 | Starting up the Module via the Registers | 37 |
| 4 | Fault and Warning Management | 49 |
| 5 | Configuration of Predefined Functions | 55 |

Chapter 3

Starting up the Module via the Registers

Introduction

This chapter describes how to start up the LULC032-033 communication module by means of the Modbus registers. It provides general information, describes the data-exchange format, the product's factory configuration and how it can be customized, and also the Modbus read and write requests.

What Is in This Chapter?

This chapter contains the following topics:

| Topic | Page |
|---|------|
| General Information on Start-up via the Registers | 38 |
| Data-Exchange Format | 39 |
| Factory Configuration | 41 |
| Customizing Your Configuration | 42 |
| Modbus Requests and Programming Examples | 47 |
| Use of the Main Registers for Simplified Management | 48 |

General Information on Start-up via the Registers

All the LULC032-033 communication module settings are implemented - or simply displayed - via the Modbus registers.

Access to Parameters

The module I/O parameters are set by one of the following three methods:

- The Modbus RJ45 port, via the application PLC
- The LUCM multifunction control unit's terminal port
- Locally, via the LUCM multifunction control unit's keypad

Data-Exchange Format

Modbus Format

Communication is based on the slave Modbus RTU protocol.

The data format is as follows:

| | | | |
|-------------|-------------|--------------|------------|
| 1 start bit | 8 data bits | 1 parity bit | 1 stop bit |
|-------------|-------------|--------------|------------|

NOTE: The detailed format of these requests is explained on the www.Modbus.org site.

Initialization

Initialization consists of two phases:

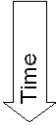
| | |
|---|--|
|  Time | <p>When the auxiliary 24 V is powered up, the LULC032-033 Modbus communication module is initialized:</p> <ul style="list-style-type: none"> • The addressing is taken into account. • The type of control unit is taken into account. |
| | <p>At the end of the initialization phase, the LULC032-033 Modbus communication module automatically identifies the configuration parameters (speed and parity) of the RS 485 link as soon as traffic is detected on the network. After analysis of up to 20 frames at a speed of 19,200 baud, initialization continues (at 1200 baud, the number of frames is higher):</p> <ul style="list-style-type: none"> • The default or configured speed is taken into account. • The Master parity is taken into account. |

Read-Write Zones

The memory zone from 0 to 19,999 can be accessed by the client.

- Reading the zone of a 'Reserved' register (or non-set) causes a correct response (value 0).

- Writing to the zone of a 'Reserved' register causes a correct response (value 0). The write operation is not taken into account and the contents remain equal to 0.

- Writing to the zone of a 'Read only' register causes a response with an exception code (code 03).

The memory zone 2000 is private and therefore reading/writing is not authorized. All accesses will be signaled by an exception code (code 02).

Exception Code

The presence of an exception code is indicated by the report from the PLC (refer to the Modbus master module documentation).

The Modbus exception codes supported are as follows:

| Value of the exception code | | Name | Comment |
|-----------------------------|---------|----------------------|---|
| Hexadecimal | Decimal | | |
| 0x01 | 1 | Illegal function | Unknown request code |
| 0x02 | 2 | Illegal data address | <ul style="list-style-type: none"> • Register address invalid • Access to the private memory zone (address \geq 20000) • Writing to a "read-only" register The memory zone is prohibited in both read and write modes |
| 0x03 | 3 | Illegal data value | <ul style="list-style-type: none"> • Invalid value The write command is interrupted |

Speed and Parity

The recognized values are as follows:

| | Possible values | Factory value |
|--------|--|---------------|
| Speed | 1200, 2400, 4800, 9600 and 19,200 baud. | 19,200 baud |
| Parity | Even, odd, no parity (parity bit deleted). | Even* |

* All versions (except LULC032 < V1.3: factory-configured with "No parity").

TSX Micro or Premium Platform

Applications for Micro and Premium PLCs are designed and implemented using PL7 software.

READ_VAR or WRITE_VAR requests (*see Modbus Requests and Programming Examples*) are used to read or write respectively the value of one or more consecutive objects of the same type (bit, word), in PL7 language.

NOTE: For more details concerning Modbus communication programming within a TSX platform, refer to the PL7 online help, Communication Volume 2/Modbus communication.

Factory Configuration

The communication module parameters are set in order to determine:

- The operating mode
- The reset mode for thermal overload faults
- The correspondence between the communication module outputs and the LUTM controller inputs

The parameter registers (Modbus protocol) are accessible in read/write mode. The factory-set values are as follows:

| Topic | Register | Factory value | Meaning |
|---|-------------------------------|---------------|---|
| Reset mode for thermal overload fault | 602.0 | 1 | "Manual" mode |
| Enable communication between LUCM/MT and LULC032 | 602.4 | 1 | Communication active |
| Fallback mode for control outputs on loss of communication | 682 | 2 | Forced stop Power base: OA1 and OA3 at 0 Controller base: 13 and 23 at 0 |
| Local operating mode or via the bus with the LUTM and LULC032 | 683 | 0 | Mode for controlling the LUTM controller outputs " remotely via the bus " |
| Inversion of the LULC032 outputs | 684 | 0 | The state of the outputs is the image of the control bits |
| On power base, assignment of: - Output LO1 - Output OA1 - Output OA3 | 685 LSB 686 LSB 686 MSB | 2 12 13 | LO1 is the state of control bit 700.0 OA1 is the state of control bit 704.0 OA3 is the state of control bit 704.1 |
| On controller base, assignment of: - Output 13 - Output 23 | 687 LSB 687 MSB | 12 13 | 13 is the state of control bit 704.0 23 is the state of control bit 704.1 |
| Recovery mode after stopping | 688 | 0 | The outputs revert to the state they were in before the power cut. |
| Control unit ID | 690 | 0 | The control unit is identified automatically |

NOTE: For more information, refer to the "TeSys U Communication Variables" User's Manual.

Customizing Your Configuration

You can use the factory settings (*see Factory Configuration*) or customize your configuration.

The following parameters can be set:

- Control unit configuration
- Control unit ID
- Timeout duration
- Fallback mode
- Control mode with a LUTM controller.
- Inversion of the output states
- Assignment of outputs LO1, OA1, OA3, 13 and 23
- Recovery after stopping
- Control unit forcing

 **WARNING**

UNEXPECTED OPERATION

A configuration can be loaded or edited via both Modbus ports (via the communication module or via the control unit LUCM). One configuration can then overwrite another, as the system does not prevent such an action. The result is not certain.

Failure to follow these instructions can result in death, serious injury, or equipment damage.

Control unit configuration (Reg 602)

Register **602** (accessible in read/write mode) is used to configure the control unit (reset mode 602.0-2, and communication 602.4).

| Reg• | Value | Comment |
|-------|-------|---|
| 602.0 | 1 | Resetting is manual (by default). Bits 1 and 2 are at 0. |
| | 0 | You have activated either bit 1 (remote reset) or bit 2 (automatic reset) |
| 602.4 | 1 | Communication with the LUCM/MT multifunction control unit has been activated. |
| | 0 | When forced to 0, this bit inhibits communication between the LUCM/MT multifunction control unit and the LULC032-033 Modbus communication module. |

Control unit configuration (Reg 680)

The control unit is identified each time the communication module is powered up.

However, the multifunction control unit memorizes the reference of the communication module assembled with it.

To use a multifunction control unit on its own, once it has been used with a communication module, identification register 680 is reinitialized locally via the keypad in the menu (Id = 0) or via the remote LUCM Modbus terminal port (value 0 written to register **680**).

Timeout Duration (Reg 681)

Register **681** (accessible in read/write mode) is used to set or read the value of the timeout on loss of communication with the PLC. Following loss of communication, the timeout corresponds to the time before switching to fallback mode. Loss of communication results in a warning, which is signaled by register 460 = 109.

| Reg• | Value | Range | Unit | Factory value | Comment |
|------|-------|-----------|-------|---------------|--|
| 681 | - | 0 - 65535 | 10 ms | 6000 | Value of timeout The value 0 represents a time of zero. |

Fallback mode (Reg 682)

Register **682** (accessible in read/write mode) is used to configure the fallback mode in the event of loss of communication with the PLC.

| Register 682 Value | Fallback Mode |
|--------------------|--------------------------|
| 0 | Ignored |
| 1 | Freeze outputs |
| 2 | Stop |
| 3 | Signal comm loss warning |
| 4 | Force run forward |
| 5 | Force run reverse |

WARNING

AUTOMATIC RESTART OF THE MOTOR

When communication stops, outputs OA1-OA3 take the status corresponding to the selected fallback mode (register 682), but command bits 704.0 and 704.1 are not modified.

During the loss of communication warning (register 703 or push button on the controller), the motor will restart automatically if command bits 704.0 or 704.1 have not been reset to zero first by the PLC application.

Failure to follow these instructions can result in death, serious injury, or equipment damage.

Description of the different fallback modes:

| Fallback Mode | Loss of Communication | Communication Recover | Loss of Communication Acknowledgement |
|---|---|---|--|
| Ignored (reg 682 = 0) | No detection of the loss of communication | No detection of the loss of communication | No acknowledgement of the loss of communication |
| | OA1 and OA3 keep their status | OA1 and OA3 keep their status | |
| Freeze outputs (reg 682 = 1) | OA1 and OA3 keep their status | OA1 and OA3 keep their status | On rising edge by bit 703.3 (do not leave set to 1) |
| | ERR LED blinking on the front face | ERR LED blinking on the front face | Once the acknowledgement is done, the last command stored in register 704 is enabled |
| | | Every new On/Off command is stored but with no impact on OA1 and OA3 | ERR LED switches off |
| Stop (reg 682 = 2) | OA1 and OA3 are forced to 0 | OA1 and OA3 are forced to 0 | On rising edge by bit 703.3 (do not leave set to 1) |
| | ERR LED blinking on the front face | ERR LED blinking on the front face | Once the acknowledgement is done, the last command stored in register 704 is enabled |
| | | Every new On/Off command is stored but with no impact on OA1 and OA3 | ERR LED switches off |
| Signal comm loss warning (reg 682 = 3) | OA1 and OA3 keep their status | OA1 and OA3 keep their status | On rising edge by bit 703.3 (do not leave set to 1) |
| | ERR LED blinking on the front face | ERR LED blinking on the front face | ERR LED switches off |
| | | Every new On/Off command is considered and has an impact on OA1 and OA3 | |
| Force run forward (reg 682 = 4) | OA1 is forced to 1 OA3 is forced to 0 | OA1 is forced to 1 OA3 is forced to 0 | On rising edge by bit 703.3 (do not leave set to 1) |
| | ERR LED blinking on the front face | ERR LED blinking on the front face | Once the acknowledgement is done, the last command stored in register 704 is enabled |
| | | Every new On/Off command is stored but with no impact on OA1 and OA3 | ERR LED switches off |

| Fallback Mode | Loss of Communication | Communication Recover | Loss of Communication Acknowledgement |
|------------------------------------|--|--|--|
| Force run reverse (reg 682 = 5) | OA1 is forced to 0 OA3 is forced to 1 | OA1 is forced to 0 OA3 is forced to 1 | On rising edge by bit 703.3 (do not leave set to 1) |
| | ERR LED blinking on the front face | ERR LED blinking on the front face | Once the acknowledgement is done, the last command stored in register 704 is enabled |
| | | Every new On/Off command is stored but with no impact on OA1 and OA3 | ERR LED switches off |

NOTE: The red 'ERR' LED flashes to indicate a loss of communication (fault on timeout).

Control Mode (Local/Bus) with an LUTM Controller (Reg 683)

Control of outputs 13 and 23 on the LUTM controller depends on the operating mode selected in register 683.

| Value | Operation | Comment |
|-------|--|---|
| 0 | 'Remote via the bus' mode | Outputs 13 and 23 are only controlled by the bus. <i>The state of inputs I.1 and I.2 does not affect outputs 13 and 23.</i> |
| 1 | 'Local' mode | Outputs 13 and 23 are only controlled by inputs I.1 and I.2. <i>Commands via the bus are not taken into account.</i> |
| 2 | 'Mixed' mode (input I.10 has priority) | |
| | 'Local' mode if I.10 = 1 | Outputs 13 and 23 are only controlled by inputs I.1 and I.2. <i>Commands via the bus are not taken into account.</i> |
| | 'Remote via the bus' mode if I.10 = 0 | Outputs 13 and 23 are only controlled via the bus, from the PLC. <i>The state of inputs I.1 and I.2 does not affect outputs 13 and 23.</i> |

NOTE: Commands transmitted during communication are passed directly to the output relays, without wiring between the communication module outputs and inputs I.1 and I.2.

Inversion of output states (Reg 684)

Depending on requirements (signaling, run, stop, etc.), it is possible to assign NO or NC behavior to outputs OA1, OA3 and LO1, by configuring register 684.

To do this, define the output concerned ==> register 684.

| Power base | Bit |
|-------------------|---------|
| Invert output OA1 | _.0 = 1 |
| Invert output OA3 | _.1 = 1 |
| Invert output LO1 | _.2 = 1 |

Modifying Output Assignments

The tables below show how the assignments of outputs LO1, OA1, OA3, 13, and 23 can be modified. To modify the assignments (factory values), write a different value (0 to 45), referring to the 'TeSys U Communication Variables' User's Manual.

| |
|---|
| ⚠ WARNING |
| UNEXPECTED OPERATION |
| Before modifying an output's assignment by means of parameterization, you must note the following information. Otherwise, you run the risk of unexpected operation. |
| Failure to follow these instructions can result in death, serious injury, or equipment damage. |

Register 704 is used for controlling the motor-starter. The following are associated with this register: functions for monitoring loss of communication, fallback mode (register 682), reflex functions or recovery mode after stopping (register 688). Only the outputs activated by bits 704.0 and 704.1 benefit from these functions.

In addition, command bits 704.0 and 704.1 are independent and can be activated simultaneously.

Using register 700 to activate outputs is comparable with unconditional forcing.

Setting the parameters of output LO1 (Reg 685 LSB)

Assignment/control (factory value) of output LO1 on the LULC032 Modbus communication module is as follows:

| Reg• | Bit | Value | Factory value | Comment |
|------|--------|---------|---------------|--------------------------------------|
| 685 | 0 to 7 | 0 to 45 | 2 | Output LO1 = state of register 700.0 |

Setting the Parameters of Output OA1 (Reg 686 LSB)

Assignment/control (factory value) of output OA1 on the LULC032-033 Modbus communication module is as follows:

| Reg• | Bit | Value | Factory value | Comment |
|------|--------|---------|---------------|--------------------------------------|
| 686 | 0 to 7 | 0 to 45 | 12 | Output OA1 = state of register 704.0 |

Setting the Parameters of Output OA3 (Reg 686 MSB)

Assignment/control (factory value) of output OA3 on the LULC032-033 Modbus communication module is as follows:

| Reg• | Bit | Value | Factory value | Comment |
|------|---------|---------|---------------|--------------------------------------|
| 686 | 8 to 15 | 0 to 45 | 13 | Output OA3 = state of register 704.1 |

Setting the Parameters of Output 13 (Reg 687 LSB)

Assignment/control (factory value) of output 13 on the LUTM controller is as follows:

| Reg• | Bit | Value | Factory value | Comment |
|------|--------|---------|---------------|-------------------------------------|
| 687 | 0 to 7 | 0 to 45 | 12 | Output 13 = state of register 704.0 |

Setting the Parameters of Output 23 (Reg 687 MSB)

Assignment/control (factory value) of output 23 on the LUTM controller is as follows:

| Reg• | Bit | Value | Factory value | Comment |
|------|---------|---------|---------------|-------------------------------------|
| 687 | 8 to 15 | 0 to 45 | 13 | Output 23 = state of register 704.1 |

Recovery mode (Reg 688)

If you use register 704 to control outputs OA1-OA3, writing the value 1 to register 688 allows you to lock the motor and prevent it restarting following the occurrence of certain events:

- Loss followed by restoration of 24V DC (outputs OA1-OA3)
- Change in position of rotary knob on power base followed by return to Ready position.

When one of these events occurs, command bits 704.0 and 704.1 (outputs OA1-OA3) are forced to 0 automatically. As long as one of these events remains pending, if values are written to register 704, the module will return exception code 02. Once these conditions have disappeared, control of the motor can be restored by sending a new run command.

⚠ WARNING**AUTOMATIC RESTART OF THE MOTOR**

In the case of cyclic writing to register 704 (e.g., an LUFFP• gateway in its predefined configuration), this monitoring function must be used with caution. The application program must take this state into account and request that bits 704.0 or 704.1 are written to 0. Otherwise, when this event disappears, the motor will restart automatically.

Failure to follow these instructions can result in death, serious injury, or equipment damage.

Forcing control unit (Reg 690)

The control unit is identified automatically, but identification can be forced.

| Value | Comment |
|-------|---|
| 0 | Default value. The system automatically identifies the type of control unit connected (standard, advanced, multifunction). |
| 1 | If the value is set to 1, this deactivates automatic identification and forces identification of a standard or advanced control unit. |
| 2 | If the value is set to 2, this deactivates automatic identification and forces identification of a multifunction control unit. |

NOTE: (Read/Write) registers 681 to 690 can also be accessed via the LUCM keypad.

Modbus Requests and Programming Examples

Modbus Requests

The recognized Modbus requests are as follows:

| Code value | | Name | Comment |
|-------------|---------|------------------------------|---|
| Hexadecimal | Decimal | | |
| 0x03 | 3 | Read multiple registers | Read mode |
| 0x06 | 6 | Write single register | Write mode |
| 0x10 | 16 | Write multiple registers | |
| 0x2B | 43 | Read register identification | Read mode for identifying the LULC032-033 Modbus communication module |

The maximum number of registers per request is limited to 100.

NOTE: The "Broadcast" function is supported. To use it, a write operation (code 6 or 16) to address 00 is necessary.

⚠ WARNING

UNEXPECTED OPERATION

Use of this device on a Modbus network that uses the broadcast function should be considered with caution.

This device has a large number of registers that must not be modified during normal operation.

Unintended writing of these registers by the broadcast function may cause unexpected and unwanted product operation.

For more information, refer to the "Internal Communication Variables" User's Manual.

Failure to follow these instructions can result in death, serious injury, or equipment damage.

Example of a Read Operation

The example below describes a READ_VAR request, within a TSX Micro or Premium platform, in order to read the motor-starter states at address 4 (slave no. 4) contained in internal word MW0:

```

If %M0 AND NOT %MW100:X0 THEN READ_VAR (ADR#3.0.4, '%MW', 455, 1, %MW0:1, %MW100:4) :RESET %M0;
EN_IF;

```

- 1 Address of the module with which you wish to communicate: 3 (module address), 0 (channel), 4 (module address on the bus)
- 2 Type of PL7 objects to be read: MW (internal word)
- 3 Address of the first register to be read: 455
- 4 Number of consecutive registers to be read: 1
- 5 Word table containing the value of the objects read: MW0:1
- 6 Read report: MW100:4

Example of a Write Operation

The example below describes a WRITE_VAR request, within a TSX Micro or Premium platform, in order to control a motor-starter by sending the content of internal word MW 502:

```

If %M0 AND NOT %MW200:X0 THEN WRITE_VAR (ADR#3.0.4, '%MW', 704, 1, %MW502:1, %MW200:4) :RESET %M10;
EN_IF;

```

- 1 Address of the module with which you wish to communicate: 3 (module address), 0 (channel), 4 (module address on the bus)
- 2 Type of PL7 objects to be written: MW (internal word)
- 3 Address of the first register to be written: 704
- 4 Number of consecutive registers to be written: 1
- 5 Word table containing the value of the objects to be sent: MW502:1
- 6 Write report: MW200:4

Use of the Main Registers for Simplified Management

Before implementing a motor-starter, it is useful to know which of the main registers are invoked, and in what order.

Diagram of Register Usage

The diagram below provides basic implementation information, using the following registers: configuration, control and monitoring (system state, measurements, faults and warnings, acknowledgment). Starting with the factory configuration (predefined), you will easily be able to follow or anticipate how your system behaves.

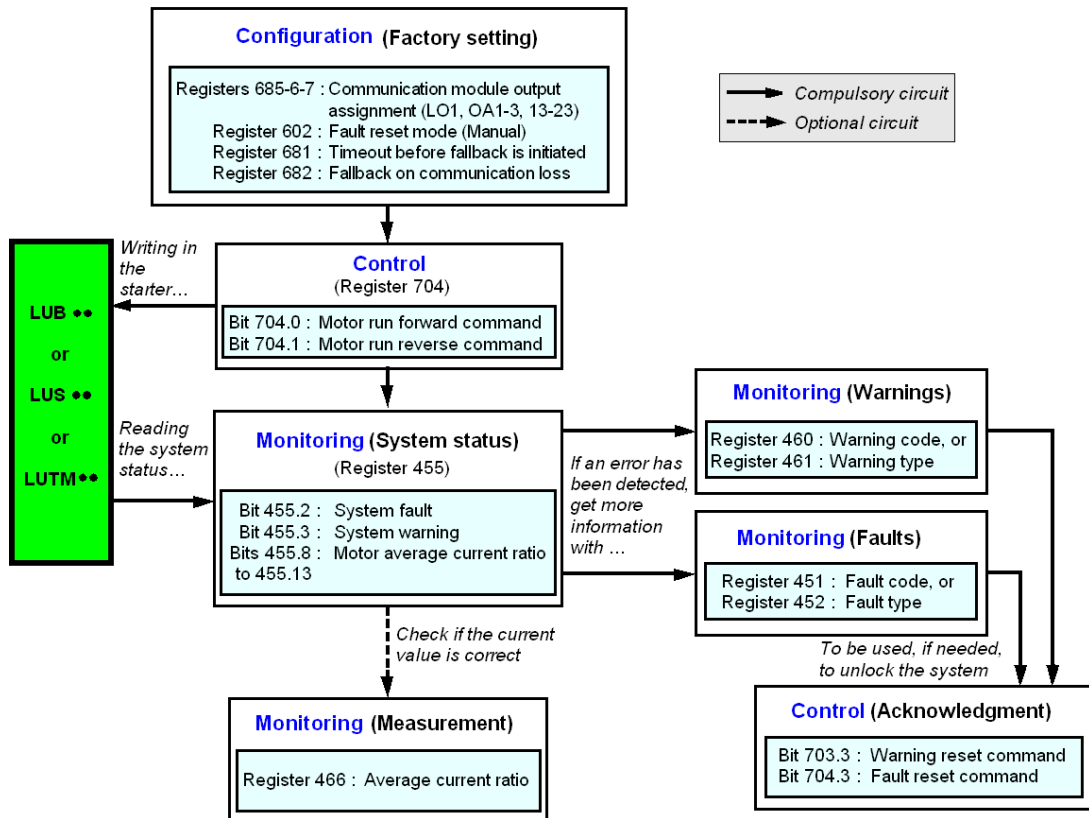

Chapter 4

Fault and Warning Management

This chapter shows how to manage the various types of fault and warning that may occur.

What Is in This Chapter?

This chapter contains the following topics:

| Topic | Page |
|----------------------------------|------|
| Displaying Faults | 50 |
| Application Faults | 51 |
| Warnings - Loss of Communication | 52 |
| Internal Faults | 53 |

Displaying Faults

The presence of a fault is signaled by various indicators:

- State of the LEDs on the LULC032-033 Modbus communication module

With a power base:

- State of the power base rotary knob (0 or "trip")
- State of the output relays

With a controller base:

- State of the LEDs on the controller base
- State of the output relays

With a standard or advanced control unit:

- Internal signals sent to the LULC032-033 Modbus communication module

With a multifunction control unit:



- Warning
- Message(s) displayed on-screen
- Internal dialog with the LULC032-033 Modbus communication module
- Presence of an exception code (report from the PLC). See *Exception Code*, [page 39](#).

NOTE: The warning and the fault are taken into account in the relevant registers. For more information, refer to the "TeSys U Communication Variables" User's Manual: fault monitoring registers (450 to 452) and warning monitoring registers (460 to 461).

Application Faults

Acknowledgement of Application Faults

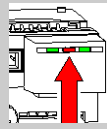
The possible application faults are listed below. Their reset (or acknowledgment) method can be: manual/automatic/remote.

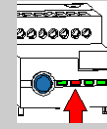
| Application faults | Registers | | LULC032 LULC033 | LUCM• | LUTM | Fault acknowledgment |
|---|---------------------|--|--|--|--|--|
| | 451 Fault number | 452 Fault bit |  "ERR" |  (line 2) |  "FAULT" | |
| Short-circuit fault | 1 | _.0 = 1 | Off | DC | - | Manual reset |
| Overcurrent fault | 2 | _.1 = 1 | | I>> | - | |
| Thermal overload fault | 4 | _.3 = 1 | | Overload | - | According to the reset mode configured in register 602 |
| Application fault in the LUCM• multifunction control unit | 3 and 5 to 12 | Refer to the User's Manual for the LUCM••BL or LUCMT1BL multifunction control unit | | | | |

Overload Fault with LU•B•/LU•S• Power Base

Following a thermal overload fault, either the rotary knob or the blue pushbutton on the front panel can be used, irrespective of which reset mode has been configured.

| Configuration register | Reset (acknowledgment) | Method |
|------------------------|------------------------|---|
| 602.0 = 1 | "Direct "manual" | With the rotary knob on LU•B• With the blue pushbutton on LU•S• |
| | "Remote "manual" | With the LU9 AP•• kit on LU•B• With the LU9 •• kit on LU•S• |
| 602.1 = 1 | "Remote" | Acknowledgment by bit 704.3 This bit is active on rising edge and must be reset to 0 by programming. |
| 602.2 = 1 | "Automatic" | Managed by the control unit |

Overload Fault with LUTM Controller Base

Following a thermal overload fault, either the blue pushbutton on the front panel or input I.5 can be used, irrespective of which reset mode has been configured.

| Configuration register | Reset (acknowledgment) | Method |
|------------------------|------------------------|---|
| 602.0 = 1 | "Local "manual" | With the blue pushbutton on the front panel |
| | "Remote "manual" | With the reset button on the front of the rack or control panel (via Input I.5) |
| 602.1 = 1 | "Remote" | Acknowledgment by bit 704.3 This bit is active on rising edge and must be reset to 0 by programming. |
| 602.2 = 1 | "Automatic" | Managed by the control unit |



NOTE: The reset mode must be configured.

Warnings - Loss of Communication

Warning Acknowledgment

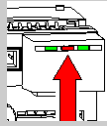
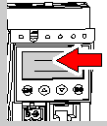
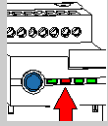
List of possible warnings.

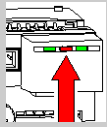
| Warnings | Registers | | LULC032 LULC033 | LUCM• | LUTM | Acknowledgment of a warning |
|---|-----------------------|---|--|--|--|--|
| | 460 Warning number | 461 Warning bit |  "ERR" |  (Line 1) |  "FAULT" | |
| Thermal overload warning | 4 | _.3 = 1 | - | Overload warning | - | Automatic when the overload is less than 85% |
| Loss of communication with the master warning | 109 | _.15 = 1 | Flashing | Comm Loss | - | Acknowledgement by bit 703.3 This bit is active on rising edge and must be reset to 0 by programming. |
| LUCM• multifunction control unit warning | 2 and 4 to 13 | Refer to the User's Manual for the LUCM••BL or LUCMT1BL multifunction control unit. | | | | |

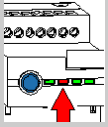
| Warnings | Registers | | LULC032 LULC033 | LUCM• | LUTM | Acknowledgment of a warning |
|--|-----------------------|--------------------|---|---|---|-----------------------------------|
| | 460 Warning number | 461 Warning bit |  "ERR" |  (Line 2) |  "FAULT" | |
| LUTM external warning indicated by I.6 changing to 0 | 201 | _.15 = 1 | - | Warn-M201 | Refer to the LUTM Controller User's Manual. | Automatic with I.6 returning to 1 |

Recovery After Loss of Communication

After acknowledgment by setting bit 703.3 to 1, recovery occurs according to the states of control bits 704.0 and 704.1.

Internal Faults

Acknowledgment of Internal Faults

List of possible internal faults.

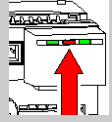
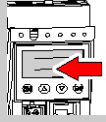
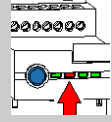
| Internal faults | Registers | | LULC032LU LC033 | LUCM• | LUTM | Fault acknowledgment |
|--|------------------------|---|--|--|--|--|
| | 451 Fault number | 452 Fault bit |  "ERR" |  (Line 2) |  "FAULT" | |
| Fault on the LULC032-033 Modbus communication module | 14 | - | Off | M14 | - | Power down and then power up the LULC032-033 and the LUCM• |
| LULC032-033 Modbus communication module not installed or not supplied with power, or loss of communication with the module | 15 | - | | M15 | - | |
| Internal fault in the LUC•• control unit | 54 | _.11 = 1 | | M54 | - | |
| Fault in the LUCM• multifunction control unit | 51 to 53, 55 to 63 | Refer to the User's Manual for the LUCM••BL or LUCMT1BL multifunction control unit. | | | | |
| Write-to-EEPROM fault | 100 | _.13 = 1 | On | M100 | - | Power down and then power up the LULC032-033 |
| Communication fault with the LUCM• multifunction control unit | 101 | _.12 = 1 | On | M101 | Flashing | Power down and then power up the LULC032-033 |
| Checksum fault in EEPROM | 102 | _.13 = 1 | On | M102 | | Rising edge on 704.3=1 |
| EEPROM configuration fault | 104 | _.13 = 1 | On | M104 | | Rising edge on 704.3=1 |
| Communication fault with the LUTM controller base | 105 | _.13 = 1 | On | M105 | Refer to the LUTM Controller User's Manual. | Power down and then power up the LULC032-033 |
| Communication fault with the LULC032-033 module | 205 | _.13 = 1 | On | - | | Power down and then power up the LUTM |
| No control unit | 206 | | | | | Power down and then power up the LUTM |

Chapter 5

Configuration of Predefined Functions

This chapter describes the predefined functions.

What Is in This Chapter?

This chapter contains the following topics:

| Topic | Page |
|--------------------------------------|------|
| Description of Reflex Stop Functions | 56 |
| Use of Reflex1 and Reflex2 | 58 |

Description of Reflex Stop Functions

The reflex stop ensures accurate repeated position control, unhindered by the bus and PLC scan times.

There are two types of reflex stop function:

- Reflex1: "Reflex stop 1" function
- Reflex2: "Reflex stop 2" function

Description of Reflex1

Sensor no. 1 (logic input LI1) directly controls motor stopping.

After a new run command (stop command then run command), the motor restarts even if something is still detected (LI1=1).

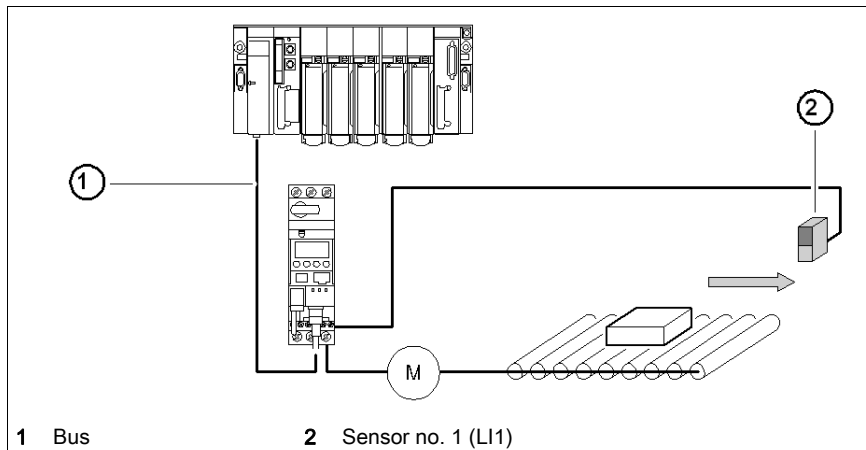

NOTE: In the case of a reversing starter, the reflex stop works in both directions.

Data sequence

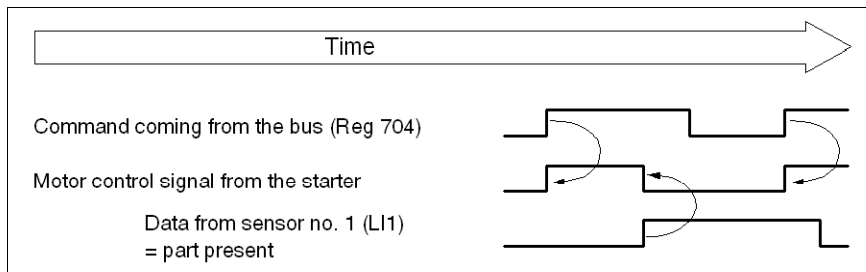

Description of Reflex2

Sensor no. 1 (logic input LI1) controls motor stopping in forward mode.

Sensor no. 2 (logic input LI2) controls motor stopping in reverse mode.

After a new run command (stop command then run command), the motor restarts even if something is still detected (LI1 or LI2 = 1).

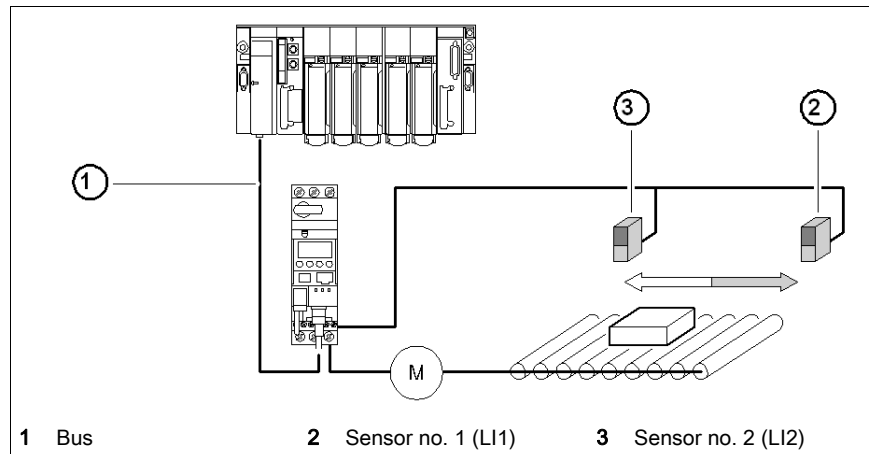

NOTE: Sensor no. 2 (LI2) does not affect forward mode and sensor no. 1 (LI1) does not affect reverse mode.

Use of Reflex1 and Reflex2

To use a "reflex stop" function, it must be selected in the register of the output to be monitored.

| Reflex function | Direction of motor rotation | Value of Reg• | LUB••/S•• - LU2B••/2S•• base | | LUTM•• base |
|-----------------|-----------------------------|---------------|------------------------------|--------------------|--------------------|
| | | | Output LO1 | Outputs OA1 OA3 | Outputs 13 23 |
| Reflex1 | Reflex1.Fw = forward | 8 | Reg685 (LSB) | Reg686 (LSB) (MSB) | Reg687 (LSB) (MSB) |
| | Reflex1.Rev = reverse | 9 | | | |
| Reflex2 | Reflex2.Fw = forward | 10 | | | |
| | Reflex2.Rev = reverse | 11 | | | |

NOTE: Before using the "reflex stop" functions, outputs OA1/OA3 must first be assigned to the forward/reverse directions. This selection is made in register **686**. By default, OA1 is assigned to forward and OA3 to reverse.

Reflex1.Fw

This function is active on a rising edge and not on the level.

| | |
|-----|--|
| .Fw | <p>L11 = 1 stops the motor, irrespective of the chosen direction of operation.</p> <p>After a new run command (stop command followed by a run command), even if logic input L11 = 1, the motor restarts in the chosen direction.</p> |
|-----|--|

NOTE: Logic input L12 is not used.

Reflex1.Rev

This function is active on a rising edge and not on the level.

| | |
|------|--|
| .Rev | <p>L11 = 1 stops the motor, irrespective of the chosen direction of operation.</p> <p>After a new run command (stop command followed by a run command), even if logic input L11 = 1, the motor restarts in the chosen direction.</p> |
|------|--|

NOTE: Logic input L12 is not used.

Reflex2.Fw

This function is active on a rising edge and not on the level.

| | |
|-----|---|
| .Fw | <p>Logic input L11 = 1 stops the motor in forward mode.</p> <p>Logic input L12 = 1 stops the motor in reverse mode.</p> <p>After a new run command (stop command followed by a run command), even if logic input L12 = 1, the motor restarts.</p> |
|-----|---|

NOTE: Logic input L12 does not affect forward mode and logic input L11 does not affect reverse mode.

Reflex2.Rev

This function is active on a rising edge and not on the level.

| | |
|------|--|
| .Rev | Logic input LI2 = 1 stops the motor in reverse mode. Logic input LI1 = 1 stops the motor in forward mode. After a new run command (stop command followed by a run command), even if logic input LI2 = 1, the motor restarts. |
|------|--|

NOTE: Logic input LI2 does not affect forward mode and logic input LI1 does not affect reverse mode.



A

Acknowledgement
 Application Fault, *51*
Acknowledgment
 Internal Fault, *53*
 Warning, *52*
Addressing, *16, 33*
Application Faults, *51*

C

Cables, *25, 26*
Conductor, *21*
Connection, *15*
 SCA Junction Box, *26*
 Splitter Box, *23*
 Tee (Direct), *22*
Connectors, *15*
Control Mode, *44*
Control unit
 configuration, *42*
 Forcing, *46*
 Identification, *42*
Control unit (LUC...), *13*
Controller Base, *16, 18*
Cords, *25, 26*

D

Data Exchange
 Exception Code, *39*
 Format, *39*
 Initialization, *39*
Diagram of the Module, *15*

E

Electrical Connection, *18*
Exception Code, *39*

F

Fallback mode, *43*
Faults, *50*
Forcing
 Control unit, *46*

I

Identification
 Control unit, *42*
Indicator Lights, *15, 15*
Input, *31*
Input (on Diagram), *15*
Internal Faults, *53*
Inversion
 Output State, *44*

J

Junction Box, *27*

L

LEDs, *15, 15*
Link
 Prewired, *19*
 Wire-to-Wire, *20*
Loss of communication, *43*
Loss of Communication, *52*
LUCA, *13*
LUCB/C/D, *13*
LUCM, *13, 18*
LULC031, *15, 32*

M

Modbus Format, *39*
Modbus Port, *31*
Modbus Request, *47*
 Read, *47*
 Write, *47*
Module, *23*
Module Functions, *13*

O

Order of Mounting, *16*
Output, *30*
 Setting, *44*
Output (on Diagram), *15*
Output State
 Inversion, *44*

P

Parameters, *38*
Parity, *39*
PCMCIA Card, *23*
Pinout (RJ45), *27*
PL7, *40*
Power Base, *16, 18*
Power Supply, *18, 19, 19, 30*
Power-up, *18*

R

Read-Write Zones, *39*
Receiving the Product, *13*
Recovery after stopping, *45*
Reflex Stop, *56*
Reflex1, *56, 58*
Reflex2, *57, 58*
Registers, *38, 41*
RJ45, *25, 25, 26, 27*
RJ45 Wiring, *25*
RS 485 Bus, *22*

S

Setting

output, *44*

Speed, *39*

Switches, *16, 33*

T

Timeout

Duration, *42*

W

Warning, *52*



1743234EN-06

Schneider Electric Industries SAS

35, rue Joseph Monier
CS30323
F - 92506 Rueil Malmaison Cedex

www.schneider-electric.com

As standards, specifications and designs change from time to time, please ask for confirmation of the information given in this publication.

07/2019