

TeSys[®] U LULC07 Profibus DP Communication Module

User's Manual

08/2019



Schneider Electric assumes no responsibility for any errors that may appear in this document. If you have any suggestions for improvements or amendments or have found errors in this publication, please notify us.

No part of this document may be reproduced in any form or by any means, electronic or mechanical, including photocopying, without express written permission of Schneider Electric.

All pertinent state, regional, and local safety regulations must be observed when installing and using this product. For reasons of safety and to help ensure compliance with documented system data, only the manufacturer should perform repairs to components.

When devices are used for applications with technical safety requirements, the relevant instructions must be followed.

Failure to use Schneider Electric software or approved software with our hardware products may result in injury, harm, or improper operating results.

Failure to observe this information can result in injury or equipment damage.

© 2019 Schneider Electric. All rights reserved.

Table of Contents



	Safety Information	5
	About the Book	7
Part I	Hardware Implementation	9
Chapter 1	Installation of the LULC07 Profibus DP Module	11
	Safety Instructions	12
	Presentation of the LULC07 Profibus DP Communication Module	13
	Description and Installation of the Module	14
	Addressing with DIP Switches	16
	Components Assembly on a Power Base	17
	Electrical Connection	18
	Connection to the Profibus DP	21
	Features of the Profibus DP	24
Chapter 2	Technical Characteristics	25
	Conditions of Use and Technical Characteristics	25
Part II	Software Implementation	27
Chapter 3	TeSys U Specific Profibus Information	29
	General Information on Implementation via Profibus DP	30
	Modules as Presented in the GS*-File	31
Chapter 4	Implementation via Profibus DP	33
	Initialization	34
	Profibus DP Application Parameter Settings	35
	Profibus DP Configuration via the SyCon Configuration Tool	37
	Factory Configuration	38
	Customizing your Configuration	39
Chapter 5	Functions to Set	43
	Functions in General	44
	Functions for Profibus DP Profiles	45
	Diagnostic Telegram for Profibus DP	57
Chapter 6	Managing Faults and Warnings	59
	Viewing a Fault	60
	Fault Reset	61
	Application Faults	62
	Warnings - Communication Loss	63
	Internal Faults	64
Chapter 7	Acyclic Data Read/Write via DP V1 and the PKW Feature	65
	Acyclic Data Read/Write via Profibus DP V1	66
	PKW: Encapsulated Acyclic Accesses in DP V0	68
	Registers Written by the Profibus Parameter Frame	71
Chapter 8	Configuration of Predefined Functions	73
	Overtravel Limit Switch (Reflex Functions)	73
Index	75



Important Information

NOTICE

Read these instructions carefully, and look at the equipment to become familiar with the device before trying to install, operate, or maintain it. The following special messages may appear throughout this documentation or on the equipment to warn of potential hazards or to call attention to information that clarifies or simplifies a procedure.



The addition of this symbol to a Danger or Warning safety label indicates that an electrical hazard exists, which will result in personal injury if the instructions are not followed.



This is the safety alert symbol. It is used to alert you to potential personal injury hazards. Obey all safety messages that follow this symbol to avoid possible injury or death.

DANGER

DANGER indicates an imminently hazardous situation which, if not avoided, **will result in** death or serious injury.

WARNING

WARNING indicates a potentially hazardous situation which, if not avoided, **can result in** death or serious injury.

CAUTION

CAUTION indicates a potentially hazardous situation which, if not avoided, **can result in** minor or moderate injury.

CAUTION

CAUTION, used without the safety alert symbol, indicates a potentially hazardous situation which, if not avoided, **can result in** equipment damage.

PLEASE NOTE

Electrical equipment should be installed, operated, serviced, and maintained only by qualified personnel. No responsibility is assumed by Schneider Electric for any consequences arising out of the use of this material.

A qualified person is one who has skills and knowledge related to the construction and operation of electrical equipment and the installation, and has received safety training to recognize and avoid the hazards involved.

About the Book



At a Glance

Document Scope

This documentation describes the installation, functions and operation of the LULC07 Profibus DP communication module.

The TeSys U system uses internal registers, that are mapped to Profibus DP parameters, Profibus DP cyclic data and Profibus DP acyclic data.

Thus, there will often be a reference to registers for detailed information about TeSys U specifics.

Area of application: mainly control system applications in the Industry and Building sectors.

Validity Note

This manual is valid for LULC07 V1.2 and later versions.

LULC07 can be used with TeSys U power bases (LUB/2B, LUS/2S) only.

LULC07 is not compatible with the TeSys U controller bases (LUTM).

Related Documents

Title of Documentation	Reference Number
LULC07 Profibus DP Module - Instruction Sheet	1639544
LU9GC7 Profibus DP Tap Module - Instruction Sheet	1639559
LU9AD7 Profibus DP Connector - Instruction Sheet	1639560
LULC07 Profibus DP Module - Beginner's Guide	1672611
LULC07 Profibus DP Module - Acyclic Data Read/Write with Siemens, Application Note	1672612
TeSys U Communication Variables - User's Manual	1744082
LU•B/LU•S• TeSys U Starters - Instruction Sheet	1629984
LUCM/LUCMT Multifunction Control Units - User's Manual	1743237
LUCM/LUCMT/LUCBT/LUCDT Control Units - Instruction Sheet	AAV40504
LUCA/LUCB/LUCC/LUCD Control Units - Instruction Sheet	AAV40503
Electromagnetic Compatibility - Practical Installation Guidelines	DEG999

You can download these technical publications and other technical information from our website at <https://www.schneider-electric.com/en/download>

Product Related Information

Up-to-date information about Profibus DP is available from the Profibus Website <http://www.profibus.com> as well as from the Profibus user organization: Profibus Nutzerorganisation e.V., Haid- und Neu-Straße 7, D-76131 Karlsruhe, Germany, or from the Profibus user organisation in your country.

Part I

Hardware Implementation

Overview

This chapter comprises information concerning the hardware implementation of the LULC07 Profibus DP communication module.

What Is in This Part?

This part contains the following chapters:

Chapter	Chapter Name	Page
1	Installation of the LULC07 Profibus DP Module	11
2	Technical Characteristics	25

Chapter 1

Installation of the LULC07 Profibus DP Module

Foreword

This chapter introduces the LULC07 Profibus DP communication module and describes the various steps involved in the hardware installation of the product.

What Is in This Chapter?

This chapter contains the following topics:

Topic	Page
Safety Instructions	12
Presentation of the LULC07 Profibus DP Communication Module	13
Description and Installation of the Module	14
Addressing with DIP Switches	16
Components Assembly on a Power Base	17
Electrical Connection	18
Connection to the Profibus DP	21
Features of the Profibus DP	24

Safety Instructions

General Instructions

WARNING

UNINTENDED EQUIPMENT OPERATION

Do not modify the GS*-file in any way.

Modifying the GS*-file can cause unpredictable behavior of the devices.

Failure to follow these instructions can result in death, serious injury, or equipment damage.

NOTE: If the GS*-file is modified in any way, the warranty of Schneider Electric will expire immediately.

WARNING

UNINTENDED EQUIPMENT OPERATION

Do not use communication variables in the management of safety devices and emergency stops.

Only use the serial link for transmitting data that is not critical to the application as there is some delay in the transmission of data relating to motor-starter states and load-current values. Data such as Forward, Reverse and Stop must not be used in safety and emergency-stop circuits.

Failure to follow these instructions can result in death, serious injury, or equipment damage.

WARNING

UNINTENDED EQUIPMENT OPERATION

- These devices must be installed, configured and used by qualified staff only.
- You must follow all current instructions, standards and regulations.
- Check the function settings before starting the motor.
- Do not downgrade or modify these devices.

Incorrect configuration can cause unpredictable behavior of the devices.

Failure to follow these instructions can result in death, serious injury, or equipment damage.

Presentation of the LULC07 Profibus DP Communication Module

Receiving the Product

On opening the box containing the LULC07 Profibus DP communication module, you should find the following items:

- An Instruction Sheet (IS), providing brief pictorial information on standard installation of the module.
- A LULC07 Profibus DP communication module equipped with connectors, except Sub-D9 Profibus DP connector.

NOTE: Check that you actually have all the items described above. Make sure that the Instruction Sheet (IS) is included, along with the correctly inserted connectors.

Functions Offered

The communication module is used to control a motor-starter remotely, via Profibus DP, from

TeSys U Starter	LUS**/LU2S**
-----------------	--------------

The control offered by the LULC07 Profibus DP communication module is used to

- read the motor-starter states
- control the motor-starter (reversing or not reversing)
- adjust the protection functions
- read the data processed in the advanced and multifunction control units
- read the input and output states of the I/O (power base)

 DANGER
IMPROPER CONTROL VOLTAGE
Do not connect voltage in excess of 24 VDC.
Only use 24 VDC to power the LULC07 Profibus DP communication module.
Failure to follow these instructions will result in death or serious injury.

Data Available

The available protection and control data depend on the control unit with which the LULC07 Profibus DP communication module is used.

There are 3 types of control unit:

- standard (reference LUCA)
- advanced (reference LUCB/C/D)
- multifunction (reference LUCM)

The table below can be used to check the data and commands you can access with each type of control unit:

Data - Commands	Control Unit		
	Standard (LUCA)	Advanced (LUCB/C/D)	Multifunction (LUCM)
Start and Stop Commands	X	X	X
Status (Ready, Running, Faulty)	X	X	X
Warning		X	X
Automatic Reset and Remote Reset via the Bus		X	X
Indication of the Motor Load		X	X
Differentiation of Faults		X	X
Remote Parameter Setting and Viewing of all Functions			X
"Log" Function			X
"Monitoring" Function			X

Description and Installation of the Module

Description of the LULC07

Connectors and LEDs on the LULC07 Profibus DP communication module.

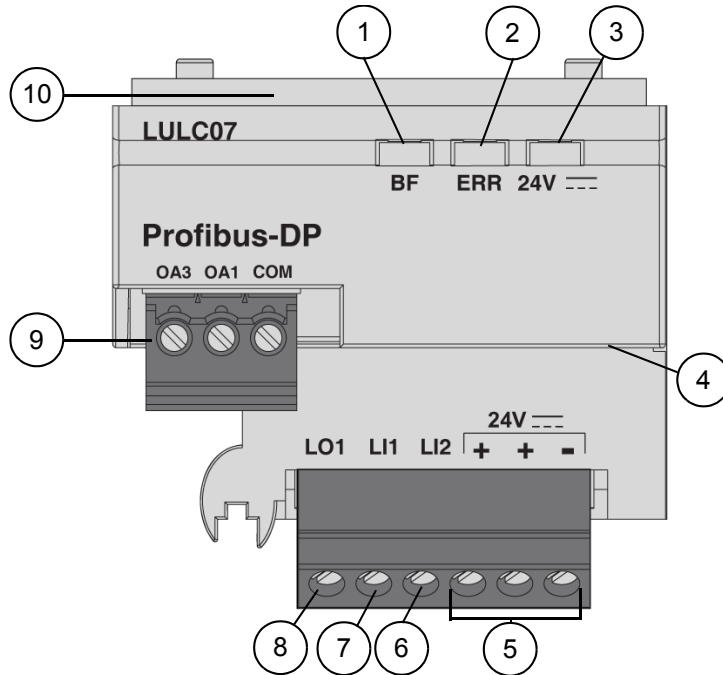

- 1 Red "BF" Profibus DP communication status LED
- 2 Red "ERR" Profibus DP communication module fault indication LED
- 3 Green "24 V ---" LED indicating voltage presence at outputs OA1, OA3, LO1
- 4 Sub-D9 connector for the Profibus DP RS485 link and the 24V Aux
- 5 Connection of the 24 V --- power supply for outputs OA1, OA3, LO1
- 6 Discrete input 2
- 7 Discrete input 1
- 8 Discrete output 1, assignable depending on the configuration register (685)
- 9 24 V --- pre-wired coil connector for the power base
 - The assignment of OA1 depends on the configuration register (686 LSB).
 - The assignment of OA3 depends on the configuration register (686 MSB).
- 10 Connector for communication with the advanced or multifunction control unit.

BF LED

The red (**BF**) LED has 3 different states:

On	communication fault
Off	communication OK
LED Blinks ● On = 2500 ms, ● Off = 500 ms	invalid Profibus DP address

Error (ERR) LED

The red error (**ERR**) LED has 3 different states:

On	internal fault
Off	OK
LED Blinks Repeatedly ● On = 500 ms ● Off = 500 ms.	Profibus DP bus connection is faulty.

24V LED

The green 24 V LED has 2 different states:

On	outputs are supplied
Off	outputs are not supplied

Addressing with DIP Switches

Addressing

The Profibus DP communication module address is defined by the DIP switches which can be accessed on the underside of the module.

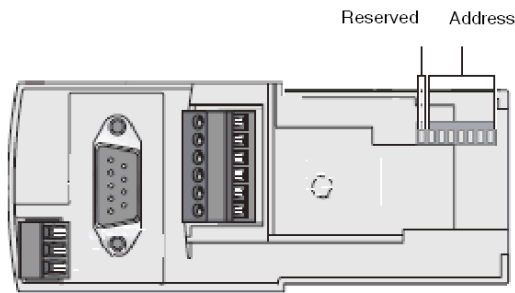

- The address code is in binary.
- **The least significant bit is on the right.**, indicated by ▲.
- Values from 1 to 125 are accepted.
- The module is factory-supplied with address 1.

Address 1:

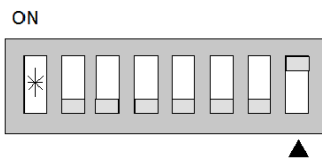

$$0000001 = 01_H = 1_{dec}$$

Invalid addresses are not taken into account by the module. The module remains in state of error.

NOTE: Addressing is only taken into account when the communication module is powered up.

Example

Example of configuration for address 48.

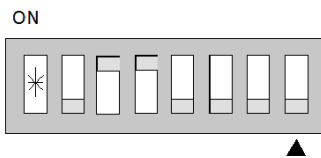

$$0110000 = 30_H = 48_{dec}$$

Components Assembly on a Power Base

Order of Mounting on a Base

The LULC07 Profibus DP communication module is installed in a power base on the underside of the control unit which locks it in position.

To install the module in the power base

Step	Action
1	Choose the prewired coil connection terminals.
2	Insert the LULC07 Profibus DP communication module.
3	Insert the control unit which locks the module.

Location of the LULC07

Location of the LULC07 Profibus DP communication module

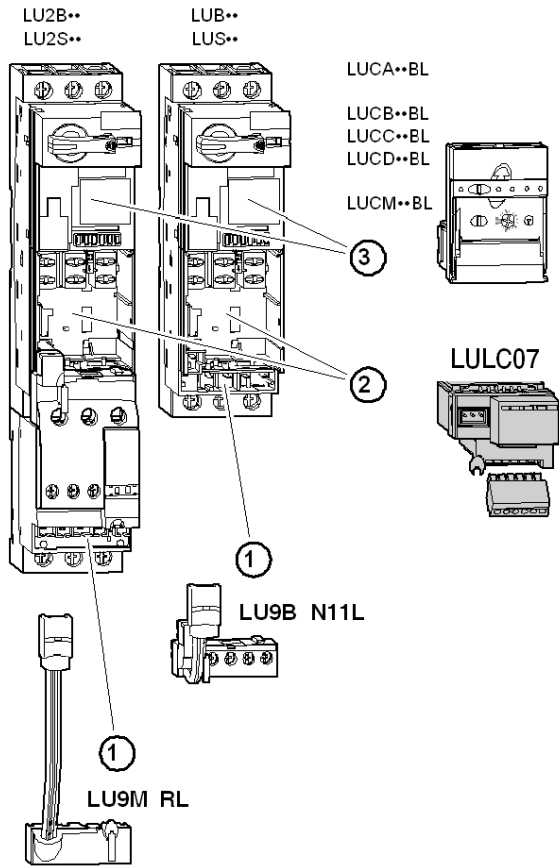

Electrical Connection

Power Supplies

Schematic of the 24 V \equiv and the 24 V Aux power supplies

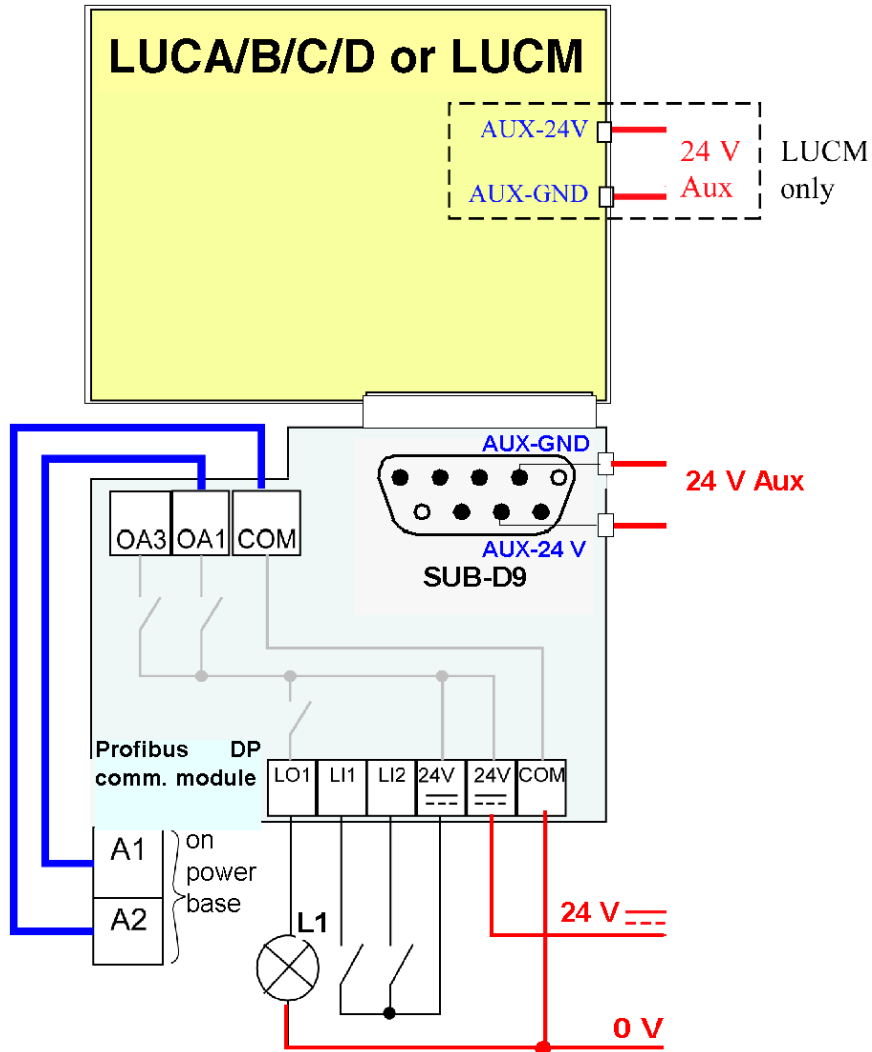

Power Up with an LUCM Multifunction Control Unit

The power supply source must be the same for the LULC07 Profibus DP communication module and the LUCM multifunction control unit.

Power Supply for the LULC07 and Outputs OA1, OA3 and LO1

In order to operate, the LULC07 Profibus DP communication module must be powered by a 24 VDC source.

24 V \equiv supply of the LULC07 communication module is provided via the Profibus DP network cable.

LUB•/LUS•/LU2B•/LU2S• power bases

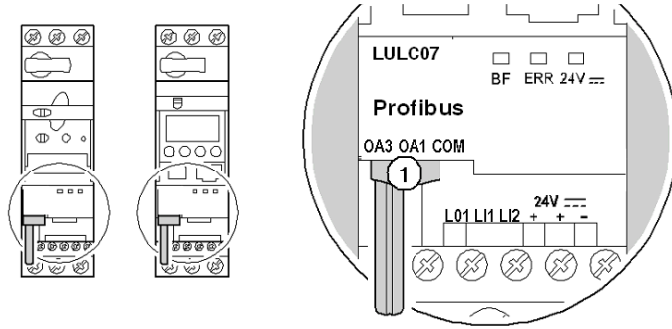

1 Link for connecting outputs OA1 and OA3 to terminals A1/A3/A2 on the starter.

Power Base Connection of Terminals A1, A2

You have 2 options for connecting the power base terminals A1, A2:

- with a pre-wired link
- with a wire-to-wire link

Wire-to-wire Link

The wire-to-wire link is a connection between outputs OA1, OA3 and Power base terminals A1 and A2. This type of link is compulsory in the case of a reversing starter-controller created from an **LU6M** reversing unit for separate assembly.

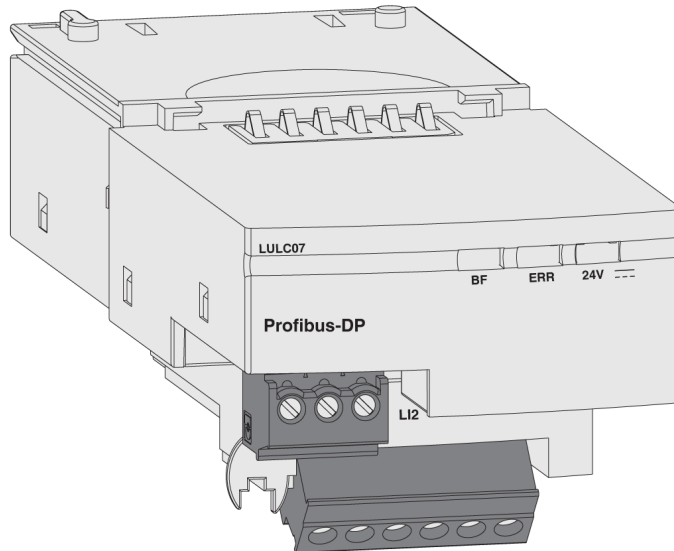

The wire-to-wire link is also used to insert for example a local control or an external stop command.

Connection Capacities of the LULC07 Terminals

The table below shows the conductor cross-sections to be used:

Connection	Type of Conductor	Cross-Section (min. - max.)	
1 conductor	<ul style="list-style-type: none"> ● solid conductor ● stranded conductor 	<ul style="list-style-type: none"> ● 0.14 ... 1 mm² ● 0.14 ... 1 mm² 	<ul style="list-style-type: none"> ● AWG 26 ... AWG 18 ● AWG 26 ... AWG 18
	Stranded conductor with cable end <ul style="list-style-type: none"> ● not insulated ● insulated 	<ul style="list-style-type: none"> ● 0.25 ... 1 mm² ● 0.25 ... 0.5 mm² 	<ul style="list-style-type: none"> ● AWG 24 ... AWG 18 ● AWG 24 ... AWG 20
2 conductors (same cross-section)	<ul style="list-style-type: none"> ● 2 solid conductors ● 2 stranded conductors 	<ul style="list-style-type: none"> ● 0.14 ... 0.5 mm² ● 0.14 ... 0.75 mm² 	<ul style="list-style-type: none"> ● AWG 26 ... AWG 20 ● AWG 26 ... AWG 18
	2 stranded conductors with cable end <ul style="list-style-type: none"> ● not insulated ● insulated 	<ul style="list-style-type: none"> ● 0.25 ... 0.34 mm² ● 0.75 mm² 	<ul style="list-style-type: none"> ● AWG 24 ... AWG 22 ● AWG 18

Connectors	3 and 6 pts	
Pitch	3.81 mm	0.15 in
Tightening Torque	0.2/0.25 N.m.	1.77/2.21 in-lb
Flat Screwdriver	2.5 mm	0.10 in

Connection to the Profibus DP

At a Glance

Profibus DP is a linear bus, designed for transfers of high speed data. The PLC communicates with its peripheral devices via a high-speed serial link.

Data exchange is mainly cyclic.

Hints and Recommendation

NOTE: Hints and recommendations need to be followed for

- wiring (Bus segment installation, wiring in and outside of buildings)
- constructing the Profibus DP cable (LU9RBnnn)
- constructing the Profibus DP connectors (LU9AD7)
- EMC measures, grounding and shielding

For more details please refer to the *Profibus DP for TeSys U Beginner's Guide*.

<h2 style="margin: 0;">⚠ WARNING</h2>
<p>UNINTENDED EQUIPMENT OPERATION</p> <ul style="list-style-type: none"> • These devices must be installed, configured and used by qualified staff only. • You must follow all current instructions, standards and regulations. • Check the function settings before starting the motor. • Do not downgrade or modify these devices. <p>Incorrect configuration can cause unpredictable behavior of the devices.</p> <p>Failure to follow these instructions can result in death, serious injury, or equipment damage.</p>

Types of Connection to the Bus

You need to connect the LULC07 communication module to the Profibus DP via a power TAP.

It is possible to connect several TeSys U modules (belonging to e.g. the same electrical cabinet) via 1 single power TAP.

The number of TeSys U modules that can be supplied by a single power TAP is only limited by the maximum current that can be delivered by 1 power TAP.

The maximum current is 1.5 A.

General Architecture with TeSys U

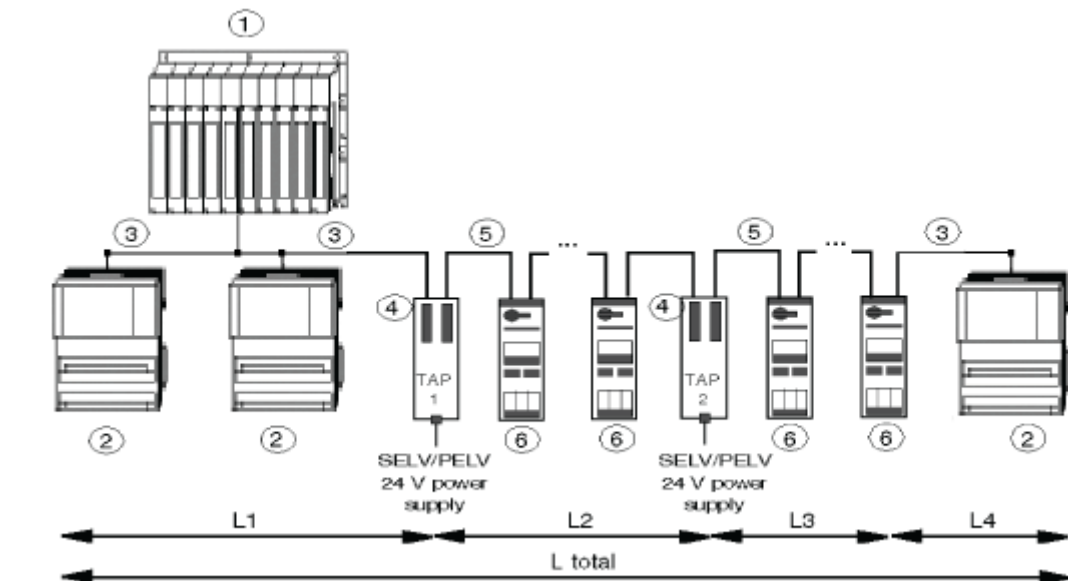

- 1 Master PLC
- 2 DP slave not powered via the bus
- 3 Profibus DP cable 2 wires (TSX PBS CA100 = 100 m, TSX PBS CA400 = 400 m)
- 4 TeSys U power TAP (LU9GC7)

- 5 Profibus DP cable 4 wires (LU9 RPB100 = 100 m, LU9 RPB400 = 400 m)
- 6 TeSys U with Profibus DP communication module (communication module: LULC07, dedicated bus connector LU9AD7)

NOTE: For detailed informations on installing the connector please refer to the respectice connector 's instruction sheet.

Use of the LU9GC7 TeSys U Power TAP

The minimum distance between 2 TeSys U Profibus DP is 0,30 m.

NOTE: Profibus connector connected to the LU9GC7 TeSys U power TAP must not support line termination.

The maximum length between the LU9GC7 where is applied the 24V SELV/PELV voltage and the last TeSys U supplied by this voltage is given in the tables below.(L2 and L3 sub-segment in the example of architecture).

Number of the TeSys U	Maximum Length Between LU9GC7 and the Last TeSys U Supplied
1	800 m (2,624 ft)
2	444m (1,456 ft)
3	278m (912 ft)
4	202m (662 ft)
5	158m (518 ft)
6	130m (426 ft)
7	110 m (360 ft)
8	96m (315 ft)
9	85m (278 ft)
10	76m (249 ft)
11	68m (ft)
12	62m (223 ft)
13	57m (187 ft)
14	53m (173 ft)
15	49m (160 ft)
16	46m (150 ft)
17	43m (141 ft)
18	40m (131 ft)
19	38m (124 ft)
20	35m (114 ft)
21	34m (111 ft)
22	32m (105 ft)
23	30m (98 ft)
24	29m (95 ft)
25	27m (88 ft)
26	26m (85 ft)
27	25m (82 ft)
28	24m (78 ft)
29	23m (75 ft)
30	22m (72 ft)
31	21m (68 ft)

NOTE: Baudrate limitations depend on the total length of the bus (L total = L1+L2+L3+L4).

Transmission Features

This table describes the transmission features of the Profibus DP bus:

Topology	Linear bus with line terminations
Transmission Mode	half duplex
Transmission Rate	9.6 / 19.2 / 45.5 / 93.75 / 187.5 / 500 / 1500 Kbits/s, 3 / 6 / 12 Mbit/s
Possible Transmission Media	twisted pair line (standard version, type RS 485) fiber optic link waveguide
Connector	Sub-D9

Max. bus length without / with 3 repeaters	Baud Rates
800 / 3200 m (2,624 / 10,498 ft)	9.6/19.2/45.5/93.75 kbit/sec
650 / 2,600 m (2,132 / 8,530 ft)	187.5 kbit/sec
300 / 1,200 m (984 / 3,936 ft)	500 kbit/sec
160 / 640 m (524 / 2,099 ft)	1.5 Mbit/sec
80 / 320 m (262 / 1,049 ft)	3/6/12 Mbit/sec

Without repeater, maximum baudrate applies to the total length of a segment (L total = L1+L2+L3+L4 in the example of general architecture above.)

Connecting the Profibus DP Bus

Female 9 point SUB-D9 connector RS 485

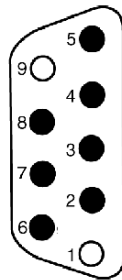

Description

Number	Signal	Description
1	(Shield):	not used
2	M24	24 V output voltage ground
3	RxD/TxD-P	positive data transmission (RD+ / TD+)
4	CNTR-P	positive repeater monitoring signal (direction monitoring)
5	DGND	data transmission ground
6	VP	line termination bias voltage
7	P24	input voltage 24 V, power supply circuit of the communication module
8	RxD/TxD-N	negative data transmission (RD- / TD-)
9	CNTR-N	(negative repeater monitoring signal, direction monitoring) not used

Features of the Profibus DP

Introduction

Profibus DP is an open industrial standard for integrated communication. It is a serial fieldbus, which provides a decentralized connection between sensors, actuators and I/O modules produced by various manufacturers, and connects them to the superset control level.

Profibus DP

Profibus DP (**D**istributed **P**eriphery - Master/Slave Network) is a Profibus communication profile which is optimized for performance. It is optimized for speed, efficiency and inexpensive hook-up cost and is designed especially for communication between automation systems and distributed peripheral equipment.

The Profibus DP network supports multiple master systems with several slaves.

Profibus DP Features

The following table contains the most important features of Profibus DP:

Standard	EN 501 70 DIN 19245
Transmission Equipment (Physical Profile)	EIA RS-485
Transfer Procedure	half-duplex
Bus Topology	linear bus with active bus termination
Bus Cable Type	shielded twisted pair conductors
Connector	9-pin D-Sub
Number of Nodes on the Bus	max. 32 with no repeaters max. 125 with 3 repeaters in 4 segments

Chapter 2

Technical Characteristics

Conditions of Use and Technical Characteristics

Characteristics

The characteristics of the LULC07 Profibus DP communication module are as follows:

- conditions of use
- 24 V $\overline{\text{---}}$ power supply for the outputs of the communication module
- 24 V Aux power supply for the internal logic of the communication module
- logic outputs OA1, OA3 and LO1
- logic inputs LI1 and LI2

Conditions of Use

The conditions of use for the LULC07 Profibus DP communication module are as follows:

Certification	UL, CSA
Conformity to Standards	IEC/EN 255-6, UL 508, CSA C22-2 No. 14
European Community Directives	CE marking. In conformity with the essential requirements of low voltage (LV) equipment and electromagnetic compatibility (EMC) directives.
Ambient Air Temperature Around the Device	storage - 40 + 85 °C (-40 +185 °F)
	operation - 25 + 55 °C (-13 +131 °F)

This is a class A product. In a residential environment this product may cause radio interference in which case you may be required to take adequate measures.

24 V $\overline{\text{---}}$ Power Supply Circuit, Outputs

Technical characteristics of the LULC07 Profibus DP communication module

Supply Voltage	U_n	24 V $\overline{\text{---}}$
	operating range	20 ... 28 V
Maximum Current Drawn	-	1.5 A
Resistance to Microbreaks	compatible with Phaseo power supply	3 ms
Protection	against overvoltage	yes
	against reverse polarity	yes

24 V Aux Power Supply Circuit, Logic

Technical characteristics of the LULC07 Profibus DP communication module

Supply Voltage	U_n	24 V $\overline{\text{---}}$ Note: To keep a SELV Profibus connector, all the Profibus participants connected on the Profibus network must have a SELV Profibus connector.
	operating range	20 ... 28 V
Maximum Current Drawn	recorded	0.08 A
Resistance to Microbreaks	compatible with Phaseo power supply	3 ms

NOTE: It is recommended to use Schneider Electric power supplies from the Phaseo product family such as e.g. ABL-7RE2402 or ABL-7CEM24.

24V power supplies must be equipped with a surge suppressor, in order to limit the transitory spreading. Keep the 24V cables away from the power cables, at least 30 cm (11.8 in.) and create crossovers at right-angles, if necessary.

Logic Outputs OA1, OA3 and LO1

Technical characteristics of the LULC07 Profibus DP communication module

Nominal Output Values	voltage	24 V $\overline{\text{---}}$
	current	500 mA
Maximum Output Values	voltage	20 ... 28 V
	current	500 mA
Coincidence Factor of the 3 Outputs	-	100%
Output Response Time (Register 704) (Time between the request start bit and the change in the output state)		<33,5 ms (OA1, OA3) for LUCA/B/C/D <35 ms (OA1, OA3) for LUCM
Protection	against overvoltage	yes
	against reverse polarity	yes
	against short-circuits and overloads	electronic circuit-breaker with automatic reset
Number of Operating Cycles	in millions of operating cycles	15
Maximum Rate	in operating cycles per hour	3600

Logic Inputs LI1 and LI2

Technical characteristics of the LULC07 Profibus DP communication module

Nominal Input Values	voltage	20 ... 28 V (positive logic)	
	current	5.8 mA	
Maximum Input Values	at state 1	voltage	>15 V
		current	>2 mA
	at state 0	voltage	<5 V
		current	<0.5 mA
Response Time	change to state 1	10 ms +/-30%	
	change to state 0	10 ms +/-30%	
Type of Input		resistive	
Protection	gl fuse	1 A	

Reaction Time

The following measurements were made with Profibus running at 1.5 MBd

Time/ms	Action	Comment
0	Output command RUN FWD	Output_0.2 = internal register 704.2
<35	Output OA1 switching	
42.6	Feedback on AO1 switching	Input_5.0 = internal register 458.0
114	Feedback on poles closed	Input_3.2 = internal register 457.2
762.7	Feedback on poles closed+Ready	Input_0.0 and 0.1 = internal register 455.0 and 455.1

NOTE: If you need fast feedback do not use Input 0.1 (455.1) but Input 3.2 (457.2) which provides basically the same information.

Part II

Software Implementation

Overview

This chapter comprises information concerning the Software implementation of the LULC07 Profibus DP communication module.

What Is in This Part?

This part contains the following chapters:

Chapter	Chapter Name	Page
3	TeSys U Specific Profibus Information	29
4	Implementation via Profibus DP	33
5	Functions to Set	43
6	Managing Faults and Warnings	59
7	Acyclic Data Read/Write via DP V1 and the PKW Feature	65
8	Configuration of Predefined Functions	73

Chapter 3

TeSys U Specific Profibus Information

Foreword

This chapter comprises general information concerning the implementation via Profibus DP.

What Is in This Chapter?

This chapter contains the following topics:

Topic	Page
General Information on Implementation via Profibus DP	30
Modules as Presented in the GS*-File	31

General Information on Implementation via Profibus DP

Overview

The TeSys U communication module supports 2 Profibus application profiles based on DP V0 and DP V1 services:

- motor starter (MS)
- motor management starter (MMS)

Cyclic/ Acyclic Services

In general, data is exchanged via cyclic services and via acyclic services.

The application profiles define for the cyclic data

- manufacturer independent data
- manufacturer specific data

The fixed set and defined use of manufacturer independent data shall allow to replace a module from vendor A by a module from vendor B.

DP V1 Read/ Write Services

DP V1 read and write services allow to access all data that cannot be accessed by cyclic data exchange.

PKW Feature

In order to make this data accessible also for DP V0 masters, a special feature, called PKW (**P**eriodically **K**ept in acyclic **W**ords), is implemented.

In cyclically exchanged data, there are encapsulated request and response frames. It will then be possible to access TeSys U system's internal registers.

See *PKW: Encapsulated Acyclic Accesses in DP V0*, [page 68](#).

NOTE: This feature can be selected/ deselected by picking the according item (module) from the list of offered choices during configuration with any Profibus configuration tool.

Modules as Presented in the GS*-File

Overview

The TeSys U system is presented as a "modular device" on Profibus DP.

The TeSys U system is described by a GS*-file. This file will be used by any Profibus configuration tool to get information about the device.

There are several possible TeSys U variants depending on:

- Control Units: advanced, multifunction, standard
- configuration mode: remote or local (only for multifunction Control Unit)
- and communication profile: motor starter or motor management starter
- and support of PKW

You have to pick one out of the following tables during the configuration.

GSD Download Procedure

The following table describes the steps to follow to download the GSD and icon files associated to Tesys U from the www.schneider-electric.com website:

Step	Action
1	Open the Schneider Electric website: www.schneider-electric.com .
2	Click Products and Services and then click Automation and Control .
3	In the Downloads section of the left menu bar, click Current offers .
4	<ul style="list-style-type: none"> • In the Choose a function drop-down list, select Motor Control. • In the Choose a range drop-down list, select TeSys U. • In the Choose a type of document drop-down list, select Software/Firmware. Click >Find .
5	Select Communication Module Tesys U PROFIBUS LULC07 and download LULC07_GSD_DIB_FILES_V100.exe file.
6	Double-click LULC07_GSD_DIB_FILES_V100.exe on your hard disk. Click Accept in the 'Licence for software downloaded from Schneider-Electric web sites' window which opens, then browse for a destination folder and click Install .

⚠ DANGER

UNINTENDED EQUIPMENT OPERATION

Do not modify the GS*-.file in any way.

Modifying the GS*-file can cause unpredictable behavior of the devices.

Failure to follow these instructions will result in death or serious injury.

NOTE: If the GS*-file is modified in any way, the Schneider Electric guarantee is immediately voided.

TeSys U Variants

Short and long description of TeSys U variants without PKW

Short Description as Shown in the GSD	Long Description (Control Unit, Local/Remote Configuration, Profibus application profile)
Sc Ad R MS V1.X	<ul style="list-style-type: none"> • advanced control unit • remote configuration via Profibus application parameters • motor starter
Sc Mu L MS V1.X	<ul style="list-style-type: none"> • multifunction control unit • local configuration • motor starter
Sc Mu L MMS V1.X	<ul style="list-style-type: none"> • multifunction control unit • local configuration • motor management starter
Sc Mu R MS V1.X	<ul style="list-style-type: none"> • multifunction control unit • remote configuration via Profibus application parameters • motor starter

Short Description as Shown in the GSD	Long Description (Control Unit, Local/Remote Configuration, Profibus application profile)
Sc Mu R MMS V1.X	<ul style="list-style-type: none"> ● multifunction control unit ● remote configuration via Profibus application parameters ● motor management starter
Sc St R MS V1.X	<ul style="list-style-type: none"> ● standard control unit ● remote configuration via Profibus application parameters ● motor starter

Short and long description of TeSys U variants with PKW

Short Description as Shown in the GSD	Long Description (Control Unit, Local/Remote Configuration, Profibus application profile)
Sc Ad R MS PKW V1.X	<ul style="list-style-type: none"> ● advanced control unit ● remote configuration via Profibus application parameters ● motor starter
Sc Mu L MS PKW V1.X	<ul style="list-style-type: none"> ● multifunction control unit ● local configuration ● motor starter
Sc Mu L MMS PKW V1.X	<ul style="list-style-type: none"> ● multifunction control unit ● local configuration ● motor management starter
Sc Mu R MS PKW V1.X	<ul style="list-style-type: none"> ● multifunction control unit ● remote configuration via Profibus application parameters ● motor starter
Sc Mu R MMS PKW V1.X	<ul style="list-style-type: none"> ● multifunction control unit ● remote configuration via Profibus application parameters ● motor management starter
Sc St R MS PKW V1.X	<ul style="list-style-type: none"> ● standard control unit ● remote configuration via Profibus application parameters ● motor starter

Local (L)/ Remote (R) configuration modes refer to configuration register 601 (read/ write with motor off), supported by Multifunction Control Unit \geq V3.x.

If in a local configuration mode...	<p>it means that 601.7 = 1. this mode preserves the local configuration made with the embedded HMI of the Multifunction Control Unit. it forbids any configuration management by PLC application through the network, thus preserving your local configuration.</p>
-------------------------------------	---

Therefore it is mandatory to select one of those TeSys U variants with the L for local configuration. If not the LULC07 will not enter data exchange!

If in a remote configuration mode...	<p>it means that 601.7 = 0 this mode enables the PLC application to remotely configure the TeSys U device. Note: The parameters overwritten by the PLC application will be lost. this mode is useful in case of faulty device replacement.</p>
--------------------------------------	--

By default, the TeSys U device equipped with a Multifunction Control Unit \geq V3.x is in remote configuration mode.

Chapter 4

Implementation via Profibus DP

Overview

This chapter comprises information concerning the implementation of the LULC07 Profibus DP communication module via Profibus DP.

What Is in This Chapter?

This chapter contains the following topics:

Topic	Page
Initialization	34
Profibus DP Application Parameter Settings	35
Profibus DP Configuration via the SyCon Configuration Tool	37
Factory Configuration	38
Customizing your Configuration	39

Initialization

Details of Initialization

	When the 24 VDC supply is powered up, the LULC07 Profibus DP communication module is initialized. <ul style="list-style-type: none">● Addressing is taken into account.● The type of control unit and base is taken into account.
	During the initialization of the Profibus DP communication link the LULC07 Profibus DP communication module automatically activates the configuration parameters for TeSys U system as received via the Profibus DP parameter frame.

NOTE: For more details about Profibus DP communication programming refer to the documentation of the PLC or Profibus DP master used.

Profibus DP Application Parameter Settings

General

You must configure the TeSys U system, via Profibus application parameters, before you can use it. You can use the factory settings (*Factory Configuration, page 38*) or customize your configuration (*Customizing your Configuration, page 39*).

List of Parameters

Depending of TeSys U variants you have access to the following list of parameters.

List of parameters for ScAd:

Parameter	Description
682	comm loss fallback strategy
684.0	invert output OA1
684.1	invert output OA3
684.2	invert output LO1
685.0 - 685.7	Output LO1 assignment
686.8 - 686.15	Output OA3 assignment
688.0	recovery mode after a stop
602.0 - 602.2	reset mode

List of parameters for ScMu:

Parameter	Description
682	comm loss fallback strategy
684.0	invert output OA1
684.1	invert output OA3
684.2	invert output LO1
685.0 - 685.7	Output LO1 assignment
686.0 - 686.7	Output OA1 assignment
686.8 - 686.15	Output OA3 assignment
688.0	recovery mode after a stop
650.0 - 650.4	control unit language
651.0	display of average current
651.1	display of thermal level
651.2	display of L1 current
651.3	display of L2 current
651.4	display of L3 current
651.5	display of ground current
651.6	display of last trip
651.7	display of phase imbalance
651.8	display of operating time
652	full load Amps setting
602.0 - 602.2	reset mode
602.3	control Unit comm. parity
602.4	comm control enable/disable
603	CU comm. on LUCM port address
604	CU comm. on LUCM port bd rate
605	overcurrent trip threshold
606	load class
607	thermal reset time (s)
608	thermal reset threshold
609	thermal warning threshold

Parameter	Description
610	ground fault trip timeout
611	ground fault trip threshold
612	ground fault warning threshold
613	phase imb. trip time starting
614	phase imb. trip time running
615	phase imb. trip threshold
616	phase imb. warning threshold
617	jam trip timeout (s)
618	jam trip threshold (%FLA)
619	jam warning threshold (%FLA)
620	undercurrent trip timeout
621	undercurrent trip threshold
622	undercurrent warn. threshold
623	long start trip timeout (s)
624	long start trip threshold
625	long start warning threshold

List of parameters for ScSt:

Parameter	Description
682	comm loss fallback strategy
684.0	invert output OA1
684.1	invert output OA3
684.2	invert output LO1
685.0 - 685.7	Output LO1 assignment
686.0 - 686.7	Output OA1 assignment
686.8 - 686.15	Output OA3 assignment
688.0	recovery mode after a stop

NOTE: For more details refer to the *TeSys U Communication Variables User's Manual*.

Profibus DP Configuration via the SyCon Configuration Tool

Introduction

With SyCon you can configure the Profibus DP network and generate an ASCII file to import into the PLC configuration in Unity Pro (or PL7 or Concept).

The following chapter illustrates the configuration with a Premium PLC.

The starting point for this example is an existing configuration with a Premium TSX PBY 100 as the Profibus DP master and a slave in a Profibus DP network.

Configuration of TeSys U System

Example of how to add a TeSys U with a Multifunction Control Unit in remote configuration mode in the network at node address 35 as "Motorstarter 17" with the Motor Starter profile (MS) as DP V0 slave.

Step	Action
1	Click Insert → Slave to open the Insert Slave window.
2	Select TeSys U Profibus as a new slave out of the Available Slaves list, press the Add>> button and confirm with OK .
3	Select slave x (TeSys U Profibus) and double click to open the Slave Configuration window.
4	Set Station address to e.g. 35.
5	Change the default Description slave x to e.g. Motorstarter 17 .
6	Select the correct combination of base and control unit (profile: motor starter SC Mu R MS V1.x). Note: Refer to <i>Functions for Profibus DP Profiles</i> , page 45.
7	Click the Common button to open the tab for the common parameters and deselect DP V1.
8	Click the Parameter Data... button to open the All Parameter Data in hex description window.
9	Click the Module button to open the Index Parameter Data window to set the application parameter values (= TeSys U remote configuration).
10	Double click on a single parameter to open an additional selection table. Here you can pick one of the offered values for e.g. the Fallback strategy .
11	Confirm the selected values with OK and close all dialog windows via their OK buttons.

Save and Export the Network Configuration

Save and export the configuration for import into the PLC configuration (PL7, Concept or Unity Pro).

Step	Action
1	Click File → Save as to open the Save as window.
2	Choose the project path and a file name and press the Save button.
3	Export, via File → Export → ASCII , the configuration as an ASCII file.
4	Now you can import the Profibus DP configuration into PLC configuration (PL7, Concept or Unity Pro.)

Factory Configuration

Setting communication module parameters allows you to determine

- the operating mode
- the reset mode on thermal overload fault

The configuration registers (600-630) and setting registers (650-688) are in a read/write access. Factory default values are

Subject	Register	Factory value	Meaning
Reset Mode After Thermal Overload Fault	602.0	1	Manual mode
Validate the Communication Between LUCM and LULC07	602.4	1	Forced to 0 (zero), this bit forbids any communication between LUCM multifunction control unit and LULC07 communication module.
Fallback Mode of Control Outputs on Communication Loss	682	2	Forced stop power base: OA1 and OA3 to 0
LULC07 Outputs Inversion	684	0	outputs status reflects control bits
Assignment of: - output LO1 - output OA1 - output OA3	685 LSB 686 LSB 686 MSB	2 12 13	LO1 reflects control bit 700.0 OA1 reflects control bit 704.0 OA3 reflects control bit 704.1
Recovery Mode After Power-Off	688	0	The outputs recover the status they had before power-off.
Identification of the Control Unit	690	0	The control unit is identified automatically.

NOTE: For more details refer to the *"TeSys U Communication Variables User's Manual"*.

Customizing your Configuration

General

You can use the factory settings (see *Factory Configuration, page 38*) or customize your configuration.

The following parameters can be set

- control unit configuration
- control unit ID
- fallback mode
- inversion of the output states
- assignment of outputs LO1, OA1, OA3.
- restart after a power cut
- control unit forcing

Access to Parameters

The communication module I/O parameters are set by

- the module Profibus DP port via the application PLC
- the multifunction control unit terminal port

Fallback Mode (Reg. 682)

Register **682** (read/write access) is used to adjust the fallback mode in case of a communication loss with the PLC. Register 682 is part of the Profibus DP module parameter frame.

Register 682 Value	Fallback Mode
0	Ignored
1	Freeze outputs
2	Stop
3	Signal comm loss warning
4	Force run forward
5	Force run reverse

⚠ WARNING

AUTOMATIC RESTART OF THE MOTOR

If communication is stopped, the outputs OA1-OA3 take the status corresponding to the selected fallback mode (register 682), but the control bits 704.0 and 704.1 are not modified.

When a loss of communication warning is acknowledged (register 703 or pushbutton on the controller), if profile MS (Motor Starter) is selected, the motor will automatically restart if the control bits 704.0 or 704.1 were not previously overwritten to zero by the PLC application.

Failure to follow these instructions can result in death, serious injury, or equipment damage.

Description of the different fallback modes:

Fallback Mode	Loss of Communication	Communication Recover	Loss of Communication Acknowledgement
Ignored (reg 682 = 0)	No detection of the loss of communication	No detection of the loss of communication	No acknowledgement of the loss of communication
	OA1 and OA3 keep their status	OA1 and OA3 keep their status	
Freeze outputs (reg 682 = 1)	OA1 and OA3 keep their status	OA1 and OA3 keep their status	On rising edge by bit 703.3 (do not leave set to 1) (703.3 = output MS 1.6 and output MMS 1.6)
	ERR LED blinking on the front face	ERR LED blinking on the front face	Once the acknowledgement is done, the last command stored in register 704 is enabled
		Every new On/Off command is stored but with no impact on OA1 and OA3	ERR LED switches off

Fallback Mode	Loss of Communication	Communication Recover	Loss of Communication Acknowledgement
Stop (reg 682 = 2)	OA1 and OA3 are forced to 0	OA1 and OA3 are forced to 0	On rising edge by bit 703.3 (do not leave set to 1) (703.3 = output MS 1.6 and output MMS 1.6)
	ERR LED blinking on the front face	ERR LED blinking on the front face	Once the acknowledgement is done, the last command stored in register 704 is enabled
		Every new On/Off command is stored but with no impact on OA1 and OA3	ERR LED switches off
Signal comm loss warning (reg 682 = 3)	OA1 and OA3 keep their status	OA1 and OA3 keep their status	On rising edge by bit 703.3 (do not leave set to 1) (703.3 = output MS 1.6 and output MMS 1.6)
	ERR LED blinking on the front face	ERR LED blinking on the front face	ERR LED switches off
		Every new On/Off command is considered and has an impact on OA1 and OA3	
Force run forward (reg 682 = 4)	OA1 is forced to 1 OA3 is forced to 0	OA1 is forced to 1 OA3 is forced to 0	On rising edge by bit 703.3 (do not leave set to 1) (703.3 = output MS 1.6 and output MMS 1.6)
	ERR LED blinking on the front face	ERR LED blinking on the front face	Once the acknowledgement is done, the last command stored in register 704 is enabled
		Every new On/Off command is stored but with no impact on OA1 and OA3	ERR LED switches off
Force run reverse (reg 682 = 5)	OA1 is forced to 0 OA3 is forced to 1	OA1 is forced to 0 OA3 is forced to 1	On rising edge by bit 703.3 (do not leave set to 1) (703.3 = output MS 1.6 and output MMS 1.6)
	ERR LED blinking on the front face	ERR LED blinking on the front face	Once the acknowledgement is done, the last command stored in register 704 is enabled
		Every new On/Off command is stored but with no impact on OA1 and OA3	ERR LED switches off

NOTE: The red **ERR** LED flashes to indicate a loss of communication (fault on Time Out).

NOTE: You can configure a fallback behavior via Reg. 682 only for the outputs controlled via Run Forward or Run Reverse (OA1 and OA3 via Reg. 704). The application parameter settings are Result of Forward direction and Result of Reverse direction. Any output controlled via reg. 700 (application parameter setting output forced by 700.x) will be driven to 0 (zero) as fallback value. This is always the case for LO1.

Inverting the Output Relays (NO <==> NC) (Reg 684)

Depending on requirements (signaling, run, stop, etc.), it is possible to assign NO or NC behavior to outputs OA1, OA3 and LO1 by configuring register **684**. Register 684 is part of the Profibus DP module parameter frame.

To do this, follow the procedure below

Action	Comment	
1	Define the output concerned ==> register 684 Output inverter: <ul style="list-style-type: none"> ● power base ○ invert output OA1 ----- ○ invert output OA3 ----- ○ invert output LO1 ----- 	bit _0 - 1 _1 - 1 _2 - 1

Action	Comment	
2	Define the assignment or control for the output concerned <ul style="list-style-type: none"> ● power base <ul style="list-style-type: none"> ○ output LO1 (Reg 685 LSB \equiv Profibus DP parameter byte 13) ○ output OA1 (Reg 686 LSB \equiv Profibus DP parameter byte 16) ○ output OA3 (Reg 686 MSB \equiv Profibus DP parameter byte 15) 	value 0 - 45

NOTE: To modify the assignment (factory value), write another value (0 to 45), referring to the list of registers.

Configuring Output LO1 (Reg 685 LSB)

Assignment/control (factory value) of output LO1 of the LULC07 Profibus DP communication module

Reg•	Bit	Value	Factory Setting	Comment
685	0 - 7	0 - 45	2	output LO1 = image of register 700.0 (control of output LO1)

Reg. 685 LSB is part of the Profibus DP module parameter frame.

Configuring Output OA1 (Reg 686 LSB)

Assignment/control (factory value) of output OA1 of the LULC07 Profibus DP communication module

Reg•	Bit	Value	Factory Setting	Comment
686	0 - 7	0 - 45	12	output OA1 = image of register 704.0 (control of output OA1)

Reg. 686 LSB is part of the Profibus DP module parameter frame.

Configuring Output OA3 (Reg 686 MSB)

Assignment/control (factory value) of output OA3 of the LULC07 Profibus DP communication module

Reg•	Bit	Value	Factory Setting	Comment
686	8 - 15	0 - 45	13	Output OA3 = image of register 704.1 (control of output OA3)

Reg. 686 MSB is part of the Profibus DP module parameter frame

Recovery Mode After Stopping (Reg 688)

If you use register 704 to control outputs OA1-OA3, writing value 1 to register 688 locks the motor and prevents it from restarting after the occurrence of certain events:

- Loss followed by restoration of 24 VDC (outputs OA1-OA3).
- Change in position of rotary knob on power base followed by return to Ready position.

When one of these events occurs, the control bits 704.0 and 704.1 (outputs OA1-OA3) are forced to 0 automatically. Once these conditions have disappeared, control of the motor can be restored by sending a new run command.

WARNING

AUTOMATIC RESTART OF THE MOTOR

In case of a cyclic writing to register 704 (e.g., an LUFPP• gateway in its predefined configuration), this monitoring function must be used with caution. The application program must take this state into account and request that bits 704.0 or 704.1 are written to 0. Otherwise, when this event disappears, the motor will restart automatically.

Failure to follow these instructions can result in death, serious injury, or equipment damage.

Control Unit Forcing (Reg 690)

The control unit is identified automatically, but identification can be forced.

Value	Comment
0	Default value. The system automatically identifies the type of control unit connected (standard, advanced, multifunction).
1	If the value is set to 1, this deactivates automatic identification and forces identification of a standard or advanced control unit. This value can be set when replacing temporary standard or advanced control unit by a multifunction in spy mode, displaying faults, currents etc.
2	If the value is set to 2, this deactivates automatic identification and forces identification of a multifunction control unit. When this value is set, standard and advanced control units are not accepted.

NOTE: This change in value is only taken into account after the communication module has been powered down and then powered up again.

NOTE: The register 690 is not included in the Profibus DP module parameter frame. The value can be changed remotely by PKW or acyclic mechanism, but this value is not updated automatically when Profibus network starts.

Chapter 5

Functions to Set

Overview

This chapter comprises information concerning the functions of the LULC07 Profibus DP communication module.

What Is in This Chapter?

This chapter contains the following topics:

Topic	Page
Functions in General	44
Functions for Profibus DP Profiles	45
Diagnostic Telegram for Profibus DP	57

Functions in General

Customizing Control

1 output LO1 which is configured by register 685.

2 free inputs LI1 and LI2.

Status Display

All the I/O managed by this module are read via the Profibus DP port.

The logic inputs (LI1 and LI2) can be used with a power base.

For details, refer to the tables in chapter *Functions for Profibus DP Profiles*, [page 45](#).

Functions for Profibus DP Profiles

General

The modes of operation depend on the used Profibus DP Application Profile. The following 2 device classes according to the Profibus DP **Low Voltage Switch Gear** profile are supported:

- motor starter (MS)
- motor management starter (MMS)

The usual motor starter uses level triggered signal.

The motor management starter uses for the cyclic data edge triggered signals.

Not every combination of a control unit with a base supports both profiles. For more information on the required combinations refer to *Modules as Presented in the GS*-File, page 31*.

Operational States (MS)

Operational states of a motor starter

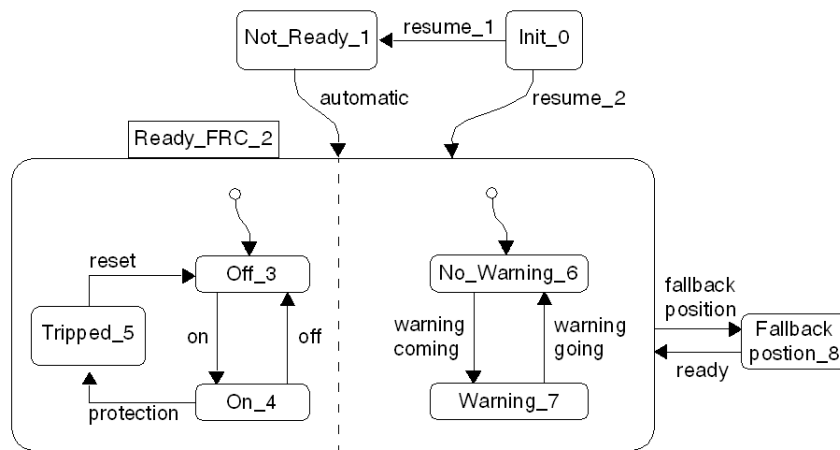

Operational States (MMS)

Example of operational states of a motor management starter (normal operation)

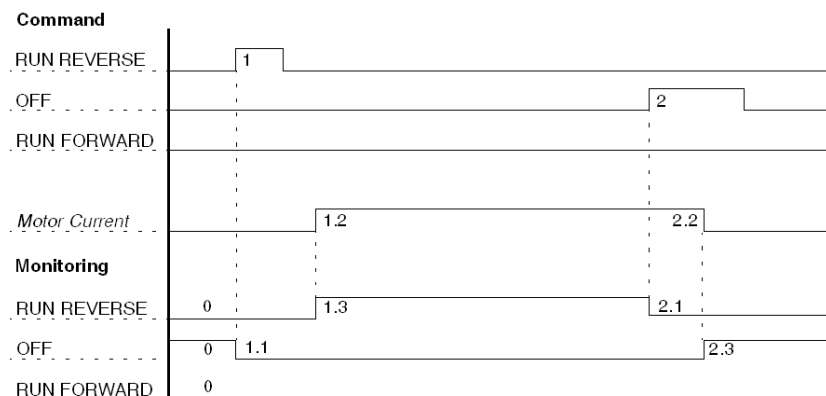

NOTE: The pulse width has to be more than 1 sec.

Sequence	Description
0	device switched off (no current, no internal stored switch-on command)
1	user: button REVERSE/FORWARD activated
1.1	- actual or internal stored switch-on command activated
1.2	- after a delay time (e.g. relay,...) current will be measured

Sequence	Description
1.3	- a measured current together with an actual or internal stored switch-on command (RUN REVERSE/FORWARD) effects the confirmation signal RUN FORWARD/REVERSE
2	user: button OFF activated
2.1	- the confirmation signal RUN FORWARD/REVERSE will be set back
2.2	- after stop of the motor no current will be measured
2.3	- no current and no (internal) stored switch-on command effects the OFF signal

Motor Starter - Data in Byte Format

Input data in byte format: Input 0 to Input 7

Position	Description	LUCA	LUCB LUCC LUCD	LUCM
Input 0.0 Ready	All the conditions that will permit the operation of a switching device by the remote host controller have been fulfilled. (455.0)	+	+	+
Input 0.1 On	The main circuit contacts are closed. (455.1)	+	+	+
Input 0.2 Fault	A fault condition exists. (455.2)	+	+	+
Input 0.3 Warning	A warning condition exists. (455.3)	+	+	+
Input 0.4 Manufacturer Specific	status register (455.4) TeSys U trip status 0 = not tripped 1 = tripped	+	+	+
Input 0.5 Manufacturer Specific	status register (455.5) reset authorized 0 = no fault or fault with reset inhibited 1 = reset is authorized now	-	+	+
Input 0.6 Manufacturer Specific	status register (455.6) control unit supplied by A1-A2 0 = control unit not supplied by A1-A2 1 = control unit supplied by A1-A2	-	-	+
Input 0.7 Manufacturer Specific	status register (455.7) motor running 0 = motor not running 1 = motor running	-	+	+
Input 1.0 - 1.5 Motor Current	The motor current expressed as a percentage of the motor rated current, ie. (455.8 - 455.13)	-	+	+
Input 1.6 Reserved	reserved for future extensions	+	+	+
Input 1.7 Ramping	start in progress (455.15): 1 = ascending current is greater than 10% FLA 0 = descending current is lower than 150% FLA	-	+	+
Input 2 Mechanical and power status MSB	mechanical and power status high byte (457.8 - 457.15) not significant	+	+	+
Input 3 Mechanical and power status LSB	mechanical and power status low byte (457.0 - 457.7) significant bits (0 - 3) of register 457: bit 0 = button position On (0 = Off) bit 1 = button position Trip (0 = Not tripped) bit 2 = contactor state On bit 3 = 24Vdc power supply present on outputs bits 4 to 7 not significant	+	+	+

Position	Description	LUCA	LUCB LUCC LUCD	LUCM
Input 4 I/O module status MSB	I/O module status high byte (458.8 - 458.15) significant bits (8 - 9) of register 458: bit 8 = LI1 status bit 9 = LI2 status bits 10 to 15 not significant	+	+	+
Input 5 I/O module status LSB	I/O module status low byte (458.0 - 458.7) significant bits (0 - 2) of register 458: bit 0 = OA1 status bit 1 = OA3 status bit 2 = LO1 status bits 3 to 7 not significant	+	+	+
Input 6 Reserved	reserved for future extensions	-	-	-
Input 7 Reserved	reserved for future extensions	-	-	-

- + available
- not available

⚠ WARNING
AUTOMATIC RESTART OF THE MOTOR
The motor will automatically restart if the Run forward (Output 0.0) and Run backward (Output 0.1) control bits were not previously overwritten to zero by the PLC application on the occurrence of one of the following events:
<ul style="list-style-type: none"> ● Loss followed by restoration of the outputs power supply 24 VDC ● Change in position of rotary knob on power base followed by return to Ready position. ● Communication break followed by restoration.
Failure to follow these instructions can result in death, serious injury, or equipment damage.

Output data in byte format: Output 0 to Output 3

Position	Description	LUCA	LUCB LUCC LUCD	LUCM
Output 0.0 Run Forward	Instructs the starter to energize the motor in the forward direction. (704.0)	+	+	+
Output 0.1 Run Reverse	Instructs the starter to energize the motor in the reverse direction. (704.1)	+	+	+
Output 0.2 Reserved	(reserved, must be 0)	-	-	-
Output 0.3 Trip Reset	Instructs the starter to reset all re-settable trips (one of the precondition for READY). (704.3)	+	+	+
Output 0.4 Emergency Start	Instructs the starter to override any fault condition and allows starting. (reset thermal memory) (705.2)	-	-	+
Output 0.5 Reserved	(reserved, must be 0)	-	-	-
Output 0.6 Reserved	(reserved, must be 0)	-	-	-
Output 0.7 Reserved	(reserved, must be 0)	-	-	-

Position	Description	LUCA	LUCB LUCC LUCD	LUCM
Output 1.0 Reserved	(reserved, must be 0)	-	-	-
Output 1.1 Reserved	(reserved, must be 0)	-	-	-
Output 1.2 Manufacturer Specific 1	(reserved, must be 0)	-	-	-
Output 1.3 Manufacturer Specific 2	(reserved, must be 0)	-	-	-
Output 1.4 Manufacturer Specific 3	initiate shunt trip (704.12)	-	-	+
Output 1.5 Manufacturer Specific 4	(reserved, must be 0)	-	-	-
Output 1.6 Manufacturer Specific 5	reset warning (703.3)	+	+	+
Output 1.7 Manufacturer Specific 6	(reserved, must be 0)	-	-	-
Output 2 Output control MSB	output control high byte (700.8 - 700.15) reserved	-	-	-
Output 3 Output control LSB	output control low byte (700.0 - 700.7) significant bits (0 - 2) of register 700: bit 0 = control of output LO1 (if 685=2) bit 1 = control of output OA1 (if 686 LSB=2) bit 2 = control of output OA3 (if 686 MSB=2) bit 3 to 7 reserved	+	+	+

- + available
- not available

Profile Motor Starter - Data in Word Little Endian Format

These tables give a description of words arrangement when the motor starter TeSys U is connected to a PLC using little endian format (example: Premium PLC).

Input data in word little endian format: Word m to Word m+3

Word Arrangement				Byte N°		
Word m	MSB	bit 15	ramping = start in progress	MS standard byte 1 Manufacturer specific (455.8 - 455.15)	Input 1	
		bit 14	not significant			
		bit 8 - 13	average motor current % FLA			
	LSB	bit 7	motor running	MS standard byte 0 (455.0 - 455.7)		Input 0
		bit 6	A1/A2 terminals powered up			
		bit 5	fault reset authorized			
		bit 4	tripped			
		bit 3	warning			
		bit 2	fault			
bit 1	on					
bit 0	ready					
Word m+1	MSB	bit 12 - 15	not significant	mechanical & power status LSB (457.0 - 457.7)	Input 3	
		bit 11	24Vdc power supply present on outputs			
		bit 10	contactor state On			
		bit 9	button position Trip (0 = Not tripped)			
	bit 8	button position On (0 = Off)				
LSB	bit 0 - 7	not significant	mechanical & power status MSB (457.8 - 457.15)	Input 2		

Word Arrangement				Byte N°	
Word m+2	MSB	bit 11 - 15	not significant	I/O Module status LSB (458.0 - 458.7)	Input 5
		bit 10	LO1 status		
		bit 9	OA3 status		
		bit 8	OA1 status		
	LSB	bit 2 - 7	not significant	I/O Module status MSB (458.8 - 458.15)	
		bit 1	LI2 status		
bit 0		LI1 status			
Word m+3	MSB		not significant (reserved for future extension)	Input 7	
	LSB		not significant (reserved for future extension)	Input 6	

Output data in word little endian format: Word n to Word n+1

Word Arrangement				Byte N°		
Word n	MSB	bit 15	reserved	MS standard byte 1 Manufacturer specific	Output 1	
		bit 14	reset warning			
		bit 13	reserved			
		bit 12	shunt trip			
		bit 8 - 11	reserved			
	LSB	bit 7	reserved	MS standard byte 0		Output 0
		bit 6	reserved			
		bit 5	reserved			
		bit 4	emergency start (705.2)			
		bit 3	trip reset			
		bit 2	reserved			
		bit 1	run reverse (704.1)			
		bit 0	run forward (704.0)			
Word n+1	MSB	bit 11 - 15	reserved	outputs control LSB (700.0 - 700.7)	Output 3	
		bit 10	control of output OA3 (if 686 MSB=2)			
		bit 9	control of output OA1 (if 686 LSB=2)			
		bit 8	control of output LO1 (if 685=2)			
	LSB	bit 0 - 7	reserved	outputs control MSB (700.8 - 700.15)		Output 2

Profile Motor Starter - Data in Word Big Endian Format

These tables give a description of words arrangement when the motor starter TeSys U is connected to a PLC using big endian format (Example: Siemens PLC)

Input data in word big endian format: Word m to Word m+6

Word Arrangement				Byte N°	
Word m	MSB	bit 15	motor running	MS standard byte 0 (455.0 - 455.7)	Input 0
		bit 14	A1/A2 terminals powered up		
		bit 13	fault reset authorized		
		bit 12	tripped		
		bit 11	warning		
		bit 10	fault		
		bit 9	on		
		bit 8	ready		
	LSB	bit 7	ramping = start in progress	MS standard byte 1 manufacturer specific (455.8 - 455.15)	Input 1
		bit 6	not significant		
bit 0 - 5		average motor current % FLA			
Word m+2	MSB	bit 8 - 15	not significant	mechanical & power status MSB (457.8 - 457.15)	Input 2
	LSB	bit 4 - 7	not significant	mechanical & power status LSB (457.0 - 457.7)	Input 3
		bit 3	24Vdc power supply present on outputs		
		bit 2	contactor state On		
		bit 1	button position Trip (0 = Not tripped)		
		bit 0	button position On (0 = Off)		
Word m+4	MSB	bit 10 - 15	not significant	I/O Module status MSB (458.8 - 458.15)	Input 4
		bit 9	LI2 status		
		bit 8	LI1 status		
	LSB	bit 3 - 7	not significant	I/O Module status LSB (458.0 - 458.7)	Input 5
		bit 2	LO1 status		
		bit 1	OA3 status		
		bit 0	OA1 status		
Word m+6	MSB	bit 8 - 15		not significant (reserved for future extension)	Input 6
	LSB	bit 0 - 7		not significant (reserved for future extension)	Input 7

Output data in word big endian format: Word n to Word n+2

Word Arrangement				Byte N°	
Word n	MSB	bit 15	reserved	MS standard byte 0	Output 0
		bit 14	reserved		
		bit 13	reserved		
		bit 12	emergency start		
		bit 11	trip reserved		
		bit 10	reserved		
		bit 9	run reverse		
		bit 8	run forward		
	LSB	bit 7	reserved	MS standard byte 1 Manufacturer specific	Output 1
		bit 6	reset warning		
		bit 5	reserved		
		bit 4	initiate shunt trip		
		bit 3	reserved		
		bit 2	reserved		
bit 1		reserved			
bit 0		reserved			
Word n+2	MSB	bit 8 - 15	reserved	outputs control MSB (700.8 - 700.15)	Output 2
	LSB	bit 3 - 7	reserved	outputs control LSB (700.0 - 700.7)	Output 3
		bit 2	control of output OA3 (if 686 MSB=2)		
		bit 1	control of output OA1 (if 686 LSB=2)		
		bit 0	control of output LO1 (if 685=2)		

Motor Management Starter - Cyclic Data in Byte Format

These tables give a description of Profile motor management starter cyclic input and output data.

Input data in byte format (only supported with multifunction Control Unit LUCM••BL): Input 0 to Input 9

Position	Description	LUCA	LUCB LUCC LUCD	LUCM
Input 0.0 Run Reverse	The main circuit contacts are closed.	-	+	+
Input 0.1 Off	Indication that the device is in the OFF-State.	-	+	+
Input 0.2 Run Forward	The main circuit contacts are closed.	-	+	+
Input 0.3 Overload Warning	A overload warning condition exists. (461.3)	-	+	+
Input 0.4 Lockout Time	not significant	-	-	-
Input 0.5 Auto Mode	Indication to a remote host controller that the commands RUN FORWARD, RUN REVERSE and STOP will / will not be accepted. 0 = LOCAL CONTROL 1 = AUTO MODE	+	+	+
Input 0.6 Fault	A fault condition exists. (455.2)	+	+	+
Input 0.7 Warning	A warning condition exists. (455.3)	+	+	+
Input 1.0	not significant	-	-	-
Input 1.1	not significant	-	-	-
Input 1.2	not significant	-	-	-
Input 1.3	not significant	-	-	-

Position	Description	LUCA	LUCB LUCC LUCD	LUCM
Input 1.4 Manufacturer Specific	ready (455.0)	+	+	+
Input 1.5 Manufacturer Specific	motor ramping start in progress (455.15): 1 = ascending current is greater than 10% FLA 0 = descending current is lower than 150% FLA	-	+	+
Input 1.6 Manufacturer Specific	motor running (455.7)	-	+	+
Input 1.7 Manufacturer Specific	tripped (455.4)	+	+	+
Input 2 IAV average current %FLA MSB	IAV average current %FLA (466.8 - 466.15)	-	+	+
Input 3 IAV average current %FLA LSB	IAV average current %FLA (466.0 - 466.7)	-	+	+
Input 4 Mechanical and power status MSB	mechanical and power status high byte (457.8 - 457.15) not significant	+	+	+
Input 5 Mechanic and power status LSB	mechanical and power status low byte (457.0 - 457.7) significant bits (0 - 3) of register 457: bit 0 = button position On (0 = Off) bit 1 = button position Trip (0 = Not tripped) bit 2 = contactor state On bit 3 = 24Vdc power supply present on outputs bits 4 to 7 not significant	+	+	+
Input 6 I/O module status MSB	I/O module status high byte (458.8 - 458.15) significant bits (8 and 9) of register 458: bit 8 = LI1 status bit 9 = LI2 status bits 10 to 15 not significant	+	+	+
Input 7 I/O module status LSB	I/O module status low byte (458.0 - 458.7) significant bits (0 - 2) of register 458: bit 0 = OA1 status bit 1 = OA3 status bit 2 = LO1 status bits 3 to 7 not significant	+	+	+
Input 8 Reserved	reserved for future extensions	-	-	-
Input 9 Reserved	reserved for future extensions	-	-	-

Output data in byte format (LUCM••BL): Output 0 to Output 5

Position	Description	LUCA	LUCB LUCC LUCD	LUCM
Output 0.0 Run Reverse	Instructs the starter to energize the motor in the reverse direction.	+	+	+
Output 0.1 Off	Instructs the device to go to the OFF-State. 0 = ENABLE RUN FORWARD/ RUN REVERSE 1 = OFF	+	+	+
Output 0.2 Run Forward	Instructs the starter to energize the motor in the forward direction.	+	+	+
Output 0.3 Self Test	Launch automatic thermal overload fault test (704.5)	-	-	+
Output 0.4 Emergency Start	reset thermal memory Instructs the starter to override any fault condition and allows starting. (705.2) Note: This command is required in process and other industries where sacrificial demands can be made on motors and associated equipment in order to achieve an orderly outcome in emergency circumstances. By setting this bit to 1, the thermal state of the motor is lost: The thermal protection will no longer protect an already warm motor.	-	-	+
Output 0.5 Auto Mode	Instructs the starter not to accept the commands Run reverse, Run Forward and Off received from the remote host. 0 = LOCAL CONTROL 1 = AUTO MODE	+	+	+
Output 0.6 Trip Reset	trip reset Instructs the starter to reset all re-settable trips (one of the precondition for READY). (704.3)	+	+	+
Output 0.7 Reserved	reserved, must be 0	-	-	-
Output 1.0 to 1.5 Reserved	reserved, must be 0	-	-	-
Output 1.6 Manufacturer Specific	reset warning (703.3)	+	+	+
Output 1.7 Manufacturer Specific	reserved, must be 0	-	-	-
Output 2 Manufacturer Specific	reserved, must be 0	-	-	-
Output 3 Manufacturer Specific	reserved, must be 0	-	-	-
Output 4 Reserved	reserved, must be 0	-	-	-
Output 5 Output control LSB	output control low byte (700.0 - 700.7) significant bits (0 - 2) of register 700: bit 0 = control of output LO1 (if 685=2) bit 1 = control of output OA1 (if 686 LSB=2) bit 2 = control of output OA3 (if 686 MSB=2) bit 3 to 7 reserved	+	+	+

- + available
- not available

Profile Motor Management Starter - Data in Word Little Endian Format

These tables give a description of words arrangement when the motor starter TeSys U is connected to a PLC using little endian format (example: Premium PLC).

Input data in word little endian format: Word m to Word m+4

Word Arrangement				Byte N°		
Word m	MSB	bit 15	tripped (455.4)	MMS standard byte 1 Manufacturer specific	Input 1	
		bit 14	motor running (455.7)			
		bit 13	motor ramping (455.15)			
		bit 12	ready (455.0)			
		bit 8 - 11	not significant			
	LSB	bit 7	warning (455.3)	MMS standard byte 0	Input 0	
		bit 6	fault			
		bit 5	auto mode			
		bit 4	not significant			
		bit 3	overload warning			
		bit 2	run forward			
		bit 1	off			
		bit 0	run reverse			
	Word m+1	MSB	bit 8 - 15	IAV average current % FLA LSB (466.0 - 466.7)	IAV average current % FLA LSB	Input 3
LSB		bit 0 - 7	IAV average current % FLA MSB (466.8 - 466.15)	IAV average current % FLA MSB	Input2	
Word m+2	MSB	bit 12 - 15	not significant	mechanical & power status LSB (457.0 - 457.7)	Input 5	
		bit 11	24Vdc power supply present on outputs			
		bit 10	contactor state On			
		bit 9	button position Trip (0 = Not tripped)			
		bit 8	button position On (0 = Off)			
	LSB	bit 0 - 7	not significant	mechanical & power status MSB (457.8 - 457.15)	Input 4	
	Word m+3	MSB	bit 11 - 15	not significant	I/O Module status LSB (458.0 - 458. 7)	Input 7
			bit 10	LO1 status		
			bit 9	OA3 status		
bit 8			OA1 status			
LSB		bit 2 - 7	not significant	I/O Module status MSB (458.8 - 458.15)	Input6	
		bit 1	LI2 status			
		bit 0	LI1 status			
Word m+4	MSB	not significant (reserved for future extension)		not significant	Input 9	
	LSB			not significant	Input 8	

Output data in word little endian format: Word n to Word n+2

Word Arrangement				Byte N°	
Word n	MSB	bit 15	reserved	MMS standard byte 1 Manufacturer specific	Output 1
		bit 14	reset warning (703.3)		
		bit 8 - 13	reserved		
	LSB	bit 7	reserved	MMS standard byte 0	Output 0
		bit 6	trip reset		
		bit 5	auto mode		
		bit 4	emergency start (705.2)		
		bit 3	self test		
		bit 2	run forward		
		bit 1	off		
bit 0		run reverse			
Word n+1	MSB	Reserved		reserved	Output 3
	LSB			reserved	Output 2
Word n+2	MSB	bit 11 - 15	reserved	outputs control LSB (700.0 - 700.7)	Output 5
		bit 10	control of output OA3 (if 686 MSB=2)		
		bit 9	control of output OA1 (if 686 LSB=2)		
		bit 8	control of output LO1 (if 685=2)		
	LSB	bit 0 - 7	reserved	outputs control MSB (700.8 - 700.15)	Output 4

Profile Motor Management Starter - Data in Big Endian Format

These tables give a description of words arrangement when the motor starter TeSys U is connected to a PLC using big endian format (Example: Siemens PLC).

Input data in word big endian format: Word m to Word m+8

Word arrangement				Byte N°	
Word m	MSB	bit 15	warning	MMS standard byte 0	Input 0
		bit 14	fault		
		bit 13	auto mode		
		bit 12	not significant		
		bit 11	overload warning		
		bit 10	run forward		
		bit 9	off		
		bit 8	run reverse		
	LSB	bit 7	tripped	MMS standard byte 1 manufacturer specific	Input 1
		bit 6	motor running		
		bit 5	motor ramping		
		bit 4	ready		
		bit 0 - 3	not significant		
Word m+2	MSB	bit 8 - 15	IAV average current % FLA MSB (466.8 - 466.15)	IAV average current % FLA MSB	Input 2
	LSB	bit 0 - 7	IAV average current % FLA LSB (466.0 - 466.7)	IAV average current % FLA LSB	Input 3

Word arrangement				Byte N°	
Word m+4	MSB	bit 8 - 15	not significant	mechanical and power status MSB (457.8 - 457.15)	Input 4
	LSB	bit 4 - 7	not significant	mechanical and power status LSB (457.0 - 457.7)	Input 5
		bit 3	24Vdc power supply present on outputs		
		bit 2	contactor state On		
		bit 1	button position Trip (0 = Not tripped)		
bit 0	button position On (0 = Off)				
Word m+6	MSB	bit 10 - 15	not significant	I/O Module status MSB (458.8 - 458.15)	Input 6
		bit 9	LI2 status		
		bit 8	LI1 status		
	LSB	bit 3 - 7	not significant	I/O Module status LSB (458.0 - 458.7)	Input 7
		bit 2	LO1 status		
		bit 1	OA3 status		
		bit 0	OA1 status		
Word m+8	MSB	bit 8 - 15	not significant (reserved for future extension)		Input 8
	LSB	bit 0 - 7	not significant (reserved for future extension)		Input 9

Output data in word big endian format: Word n to Word n+4

Word arrangement				Byte N°	
Word n	MSB	bit 15	reserved	MMS standard byte 0	Output 0
		bit 14	trip reset		
		bit 13	auto mode		
		bit 12	emergency start (705.2)		
		bit 11	self test		
		bit 10	run forward		
		bit 9	off		
	bit 8	run reverse			
	LSB	bit 7	reserved	MMS standard byte 1 Manufacturer specific	Output 1
		bit 6	reset warning		
bit 0 - 5		reserved			
Word n+2	MSB	bit 8 - 15		reserved	Output 2
	LSB	bit 0 - 7		reserved	Output 3
Word n+4	MSB	bit 8 - 15	reserved	outputs control MSB (700.8 - 700.15)	Output 4
	LSB	bit 3 - 7	reserved	outputs control LSB (700.0 - 700.7)	Output 5
		bit 2	control of output OA3 (if 686 MSB=2)		
		bit 1	control of output OA1 (if 686 LSB=2)		
bit 0	control of output LO1 (if 685=2)				

Diagnostic Telegram for Profibus DP

Diagnostic Telegram for Profibus DP

Structure of the diagnostic telegram for Profibus DP

Byte 0-9

DP V1 Byte	Byte Name	Description
0	stations_status_1	Profibus DP standard diagnostic data. Mandatory for each Profibus DP slave. This data gives an overview of the Profibus DP communication.
1	stations_status_2	
2	stations_status_3	
3	diag.master_add	
4	ident number high	
5	ident number low	
6	Header Byte	Device related diagnostic which length includes the header
7	-	DPV1: 0x81 = status, type: diagnostic Warning
8	-	DPV1: slot number e.g. 0x01
9	-	DPV1: warning specifier e.g. 0x00 = not specified

Byte 10-13

DP V0/V1 Byte	Byte Name	Description	
10	Manufacture Specific ID	identifier control unit, base	
		10.0 - 10.3	Control unit: 1 = LUCA**BL 2 = LUCB**BL, LUCC**BL, LUCD**BL 3 = LUCM**BL
		10.4 - 10.7	Base: 1 = LU2B**, LU2S*S, LUB**, LUS**
11	Profibus DP Device Status	state of the Profibus DP fieldbus handler	
		11.0	Local/ remote: 0 = Profibus DP parameters have priority 1 = Parameters set locally are not overwritten by Profibus DP parameter frame.
		11.1 - 11.6	are reserved for further use
		11.7	Profibus DP application profile: 0 = motor starter 1 = motor management starter
12	Internal info HB	used only for development internal use (call back return value)	
13	Internal info LB	Report errors with internal communication handler.	
		13.0	1, if setting registers have tried to be written from a Profibus parameter frame received when the motor was running
		13.1	1, if writing values from the Profibus parameter frame failed even when the motor was not running]
		13.2 - 13.7 for development internal use only	
		13.2	1, if an internal error occurred during generation of the Profibus diagnostic frame
		13.3	1, if the internal cyclic data exchange (callback) failed

Byte 14-15

DP V0/V1 Byte	Byte Name	Description
14	(455.8 - 455.15)	TeSys U status register
15	(455.0 - 455.7)	TeSys U status register

Byte 16-19

DP V0/V1 Byte	Byte Name	Description	
16	(456.8 - 456.15)	spare	
17	(456.0 - 456.7)	17.0 - 17.1	not significant
		17.3 - 17.7	spare
18	(457.8 - 457.15)	spare	
19	(457.0 - 457.7)	19.0 - 19.7	not significant

Byte 20-35

DP V0/V1 Byte	Byte Name	Description
20	(460.8 - 460.15)	warning number
21	(460.0 - 460.7)	warning number
22	(461.8 - 15)	warning register (bit = 1 when warning)
23	(461.0 - 461.7)	warning register (bit = 1 when warning)
24	(462.8 - 462.15)	2nd warning register, always 0
25	(462.0 - 462.7)	2nd warning register, always 0
26	(463.8 - 463.15)	3rd warning register, always 0
27	(463.0 - 463.7)	3rd warning register, always 0
28	(451.8 - 451.15)	fault number register
29	(451.0 - 451.7)	fault number register
30	(452.8 - 452.15)	fault register 1
31	(452.0 - 452.7)	fault register 1
32	(453.8 - 453.15)	fault register 2, always 0
33	(453.0 - 453.7)	fault register 2, always 0
34	(454.8 - 454.15)	3rd fault register, always 0
35	(454.0 - 454.7)	3rd fault register, always 0

NOTE: The transmission of the diagnostic frame is caused only by changes in the registers 451 and 460. Nevertheless more information is provided by the diagnostic frame. Attention: Changes in registers other than 451 or 460 do not cause the transmission of the diagnostic frame!

Chapter 6

Managing Faults and Warnings

Overview

This chapter explains how to manage the different types of faults and warnings that may occur.

What Is in This Chapter?

This chapter contains the following topics:

Topic	Page
Viewing a Fault	60
Fault Reset	61
Application Faults	62
Warnings - Communication Loss	63
Internal Faults	64

Viewing a Fault

Fault Indicators

A fault is being signalled by different indicators:

- status of LULC07 Profibus DP communication module's LEDs,
- with a power base:
 - status of rotary button on the power base (0 or "trip"),
 - status of outputs,
- with a standard or advanced control unit:
 - internal signals sent to LULC07 Profibus DP communication module,
- with a multifunction control unit:
 - warning,
 - message(s) displayed on screen,
 - internal communication with the LULC07 Profibus DP communication module,
 - presence of an exception code (PLC report).

NOTE: Warnings and faults are being considered in specific registers. Refer to *TeSys U Communication Variables User's Manual*: fault monitoring registers (450 - 452) and warning monitoring registers (460 - 461).

Fault Reset

Fault Resets with an LU•B•/LU•S• Power Base



After a thermal overload fault, the rotary switch on the front can be used, whatever reset mode was set.

Modbus Configuration Register	Reset (Acknowledgment)	Method
602.0 = 1	local "manual"	with the rotary switch on LU•B• with the blue push-button on LU•S•
	remote "manual"	with the LU9 AP•• kit on LU•B• with the LU9 •• kit on LU•S•
602.1 = 1	"remote"	acknowledged by bit 704.3 (bit 704.3 = Profibus DP output MS 0.3 or MMS 0.6) This bit is active on rising edge and must be reset to 0 by programming
602.2 = 1	"automatic"	managed by the control unit

Application Faults

Acknowledgment of Application Faults

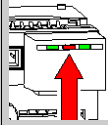
Possible application faults are listed hereunder. They can be reset (acknowledged): manually / automatically / remotely.

Application Faults	Registers		LULC07	LUCM•	Fault Acknowledgment
	451 Fault Number (Profibus DP Diagnostic Byte 28+29)	452 Fault Bit (Profibus DP Diagnostic Byte 30+31)	 "ERR"	 (Line 2)	
Short-circuit Fault	1	31.0 = 1	off	SC	manual reset
Over-current Fault	2	31.1 = 1		I>>	
Thermal Overload Fault	4	31.3 = 1		overload	depending on reset mode set in register 602 (Reg 602 ≡ Profibus DP parameter byte 52)
Application Fault in the LUCM• Multifunction Control Unit	3, and 5 - 12	<i>See LUCM Multifunction Control Unit User's Manual.</i>			

Warnings - Communication Loss

Warning Acknowledgment

Possible warnings are listed hereunder:

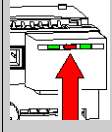
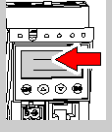
Warnings	Registers		LULC07	LUCM•	Fault Acknowledgment
	460 Warning Number	461 Warning Bit	 "ERR"	 (Line 1)	
Thermal Overload Warning	4	452.3 = 1	-	overload warning	automatic when the overload is less than 85%
Loss of Communication with the LULC07 Profibus DP Communication Module Warning	109	(not applicable)	Flashing	comm loss	acknowledged by bit 703.3 (bit 703.3 = Profibus DP output MS 1.6 or MMS 1.6) This bit is active on rising edge and must be reset to 0 by programming
LUCM• Multifunction Control Unit Warning	1 - 3, 5 - 13	<i>See LUCM Multifunction Control Unit User's Manual.</i>			



Recovery After Loss of Communication

With MS profile, after acknowledgment by rising edge on bit 703.3, recovery occurs depending on the status of control bits 704.0 and 704.1 (bit 704.0 - 704.3 = Profibus DP output MS 0.0 to MS 0.3).

Internal Faults

Acknowledgment of internal Faults

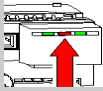
Possible internal faults are listed hereunder:

Internal Faults	Registers		LULC07	LUCM•	Fault Acknowledgment
	451 Fault Number (Profibus DP Diagnostic Byte 28+29)	452 Fault Bit (Profibus DP Diagnostic Byte 30+31)	 "ERR"	 (line 2)	
LULC07 Profibus DP Communication Module Fault	14	-	off	M14	power the LULC07 and the LUCM• off and then on
LULC07 Profibus DP Communication Module Not Installed or Not Supplied With Power	15	-			
LUC•• control Unit Internal Fault	54	452.11 = 1		M54	
LUCM• Multifunction Control Unit Fault	51 - 53, 55 - 63	<i>See LUCM Multifunction Control Unit User's Manual.</i>			
Write to EEPROM Fault	100	452.13 = 1	on	M100	power the LULC07 off and then on
Communication Fault with the LUCM• Multifunction Control Unit	101	30.2 = 1	on	M101	power the LULC07 off and then on
Checksum-on-EEPROM Fault	102	452.13 = 1	on	M102	acknowledged by bit 704.3 (bit 704.3 = Profibus DP output MS 0.3 or MMS 0.6)
EEPROM Configuration Fault	104	452.13 = 1	on	M104	This bit is active on rising edge and must be reset to 0 by programming

Remark: "MSm.n." stands for "Motorstarter, byte m, bit n".

Chapter 7

Acyclic Data Read/Write via DP V1 and the PKW Feature

Overview

The TeSys U system provides much more data than is exchanged cyclically. Only data, that is necessary and defined in the application profiles, is exchanged.

All other data is provided on demand via acyclic DP V1 (Profibus Decentral Periphery Version 1) read and write services.

Using slot/index and length addressing, blocks of TeSys U system internal registers can be mapped into acyclic frames on Profibus DP. These services are available only via Profibus DP masters providing those DP V1 services.

As there are Profibus DP masters that do not provide DP V1 services the PKW feature is implemented to allow acyclic read or write accesses being encapsulated through DP V0.

Any register setting that had been modified via not cyclic DP V1 or PKW write accesses might be overwritten by the Profibus parameter frame during node initialization. Please find a list of registers written by the Profibus parameter frame at the end of this chapter (*see page 71*).

Do not use acyclic write via DP V1 or the PKW feature to write registers which are written cyclically (see *Functions to Set, page 43* to have the list of registers exchanged cyclically), they will be overwritten immediately.

What Is in This Chapter?

This chapter contains the following topics:

Topic	Page
Acyclic Data Read/Write via Profibus DP V1	66
PKW: Encapsulated Acyclic Accesses in DP V0	68
Registers Written by the Profibus Parameter Frame	71

Acyclic Data Read/Write via Profibus DP V1

Overview

For acyclic DP V1 accesses a mechanism, based on slot/index and length-addressing, is implemented in LULC07.

Please note that the data exchanged via acyclic DP V1 read or write accesses are word oriented, even if the length is counted in bytes.

Calculation Rule

Calculation of slot/index and length

Address	Calculation
Slot	constant value (always 1)
Index	register / 10
Length	(number of registers) x 2 [bytes]

Index

The index is always a rounded down integer.

The highest supported index is 223.

Length

The maximum length is 20 registers (40 bytes).

NOTE: Basically the internal registers can be accessed in steps of 10 registers. The length, matching to this stepping, will be 10 registers (20 bytes). Nevertheless any length between 2 and 40 bytes is possible, but should be chosen according to the TeSys U internal registers.

Examples

Reading the communication Modbus identification (Reg. 050-063)

Address	Calculation	Value
Slot	constant value (always 1)	1
Index	050 / 10	5
Length	[14 Reg. (050-063)] x 2	28 bytes

Reading the Reg. 060-063)

Address	Calculation	Value
Slot	constant value (always 1)	1
Index	060 / 10	6
Length	[4 Reg. (060-063)] x 2	8 bytes

Reading Acyclic Data (DS_Read)

With the function `DS_Read` the Profibus DP master can read data from the slave.

The data is addressed via slot/index and length.

Byte	Name	Meaning
0	function number = 0x5F	DS_Read function
1	slot number (1)	
2	index (2..223)	
3	length ≤ 20 registers (40 bytes)	
4.. length +3	data read	data bytes

Sending Acyclic Data (DS_Write)

With the function `DS_Write` the Profibus DP master can send data to the slave.

The data is addressed via slot/index and length.

Byte	Name	Meaning
0	function number = 0x5F	DS_Write function
1	slot number (1)	
2	index (2..223)	
3	length ≤ 20 registers (40 bytes)	
4.. length +3	data to be written	data bytes

Feedback in Case Of Error

If the access is not possible, none register is accessed and an error value will be returned via DP V1.

The four first bytes of the response on DP in the case of an error are as follows:

Byte	Value	Meaning
0	0xDE/ 0xDF	for DS_Read/ DS_Write
1	0x80	indicating DP V1
2	0xB6	error class + error code1 = access denied
3	0x??	error code 2, LULC07 specific (see following table)

Error Code2, LULC07 Specific

Error Code 2	Meaning
01	internal stack request full
03	register not managed or super user access rights needed
06	register defined but not written
07	not all registers found
08	registers not authorized to be written
10	written value not in the range of the register, word value too big (too high)
11	written value not in the range of the register, word value too small (too low)
12	written value not in the range of the register, (MSB value too big)
13	written value not in the range of the register, (MSB value too small)
14	written value not in the range of the register, (LSB value too big)
15	written value not in the range of the register, (LSB value too small)
16	written value not a valid value
20	multifunction Control Unit rejects, sends back an error frame
255	internal error

Presentation of error code and error class to the user logic depends on the master implementation (for example the PLC).

As the mechanism can access only blocks of parameters starting at a dedicated parameter (MB address) also not existing parameters (MB addresses) will be accessed. The data value read will be 0x00, but in case of writing it is necessary to write the value 0x00. If not, the complete write access will be rejected.

Updating the Display of a Multifunction Control unit

In case the modification of a register should affect the display at the multifunction control unit, take care that the change will be effective only after a user inter action at the display.

(For example select another line by the up/down arrow).

TeSys U Internal Registers

NOTE: For more details about the TeSys U internal registers please refer to the *TeSys U Communication Variables User's Manual*.

PKW: Encapsulated Acyclic Accesses in DP V0

Overview

Some Profibus DP masters do not provide DP V1 services. The PKW feature is implemented to allow acyclic read or write accesses to be encapsulated in DP V0.

This feature is enabled in the Profibus DP configuration tool by selecting the appropriate module. For each module, a second entry with PKW exists.

The PKW data is added to the cyclic data.

Read/Write Registers

With the PKW data, you can read or write any register. The 8 bytes are interpreted as a request telegram or a response telegram encapsulated in IN data and OUT data.

PKW OUT Data

PKW OUT Data request (Profibus DP Master → LULC07) are mapped in modules supporting PKW.

To access a register, you must select 1 of the following function codes:

- R_REG_16 = 0x25 to read 1 register
- R_REG_32 = 0x26 to read 2 registers
- W_REG_16 = 0x2A to write 1 register
- W_REG_32 = 0x2B to write 2 registers.

Register numbers are given in TeSys U Communication Variables User's Manual.

Word 1	Word 2			Word 3	Word 4
Register address	Toggle bit (bit 15)	Function bits (bits 8 - 14)	Not used (bits 0 - 7)	Data to write	
Register number	0/1	R_REG_16 Code 0x25	0x00	–	–
		R_REG_32 Code 0x26		–	–
		W_REG_16 Code 0x2A		Data to write in register	–
		W_REG_32 Code 0x2B		Data to write in register 1	Data to write in register 2

Depending on the PLC platform used, refer to the PKW OUT description in Little and Big endian formats to know the positioning of each field inside each word.

Any changes in the function field will trigger the handling of the request (except if Function code = 0x00).

Toggle bit must change at each consecutive request. This mechanism allows the request initiator to detect that a response is ready by polling the toggle bit in response. When this bit in the OUT data becomes equal to the response emitted toggle bit in the IN data, then the response is ready.

PKW IN Data

PKW IN Data Response (LULC07 → Profibus DP Master) are mapped in modules supporting PKW. The LULC07 communication module echoes the same register address and function code or eventually an error code:

Word 1	Word 2			Word 3	Word 4
Register address	Toggle bit (bit 15)	Function bits (bits 8 - 14)	Not used (bits 0 - 7)	Data to write	
Same register number as in request	Same as request	ERROR Code 0x4E	0x00	Error code	
		R_REG_16 Code 0x25		Data read in register	_
		R_REG_32 Code 0x26		Data read in register 1	Data read in register 2
		W_REG_16 Code 0x2A		-	-
		W_REG_32 Code 0x2B		-	-

Depending on the PLC platform used, refer to the PKW IN description in Little and Big endian formats to know the positioning of each field inside each word.

If the initiator tries to write a TeSys U object or register to an unauthorized value, or tries to access an inaccessible register, an error code is answered (Function code = toggle bit + 0x4E). The exact error code can be found in words 3 and 4. The request is not accepted and the object or register remains at the old value.

If you want to re-trigger exactly the same command, you must:

- reset the Function code to 0x00,
- wait for the response frame with the function code equal to 0x00, then
- set it again to its previous value.

This is useful for a limited master like an HMI.

Another way of re-triggering exactly the same command is to:

- invert the toggle bit in the function code byte.

The response is valid when the toggle bit of the response is equal to the toggle bit written in the answer (this is a more efficient method, but it requires higher programming capabilities).

PKW Error Codes

Case of a write error:

Error Code	Error Name	Explanation
1	FGP_ERR_REQ_STACK_FULL	external request: sends back an error frame
3	FGP_ERR_REGISTER_NOT_FOUND	register not managed (or the request needs super user access rights)
4	FGP_ERR_ANSWER_DELAYED	external request: answer postponed
7	FGP_ERR_NOT_ALL_REGISTER_FOUND	one or both registers cannot be found
8	FGP_ERR_READ_ONLY	register not authorized to be written
10	FGP_ERR_VAL_1WORD_TOOHIGH	written value not in the range of the register (word value is too high)
11	FGP_ERR_VAL_1WORD_TOLOW	written value not in the range of the register (word value is too low)
12	FGP_ERR_VAL_2BYTES_INF_TOOHIGH	written value not in the range of the register (MSB value is too high)
13	FGP_ERR_VAL_2BYTES_INF_TOLOW	written value not in the range of the register (MSB value is too low)
16	FGP_ERR_VAL_INVALID	written value not a valid value
20	FGP_ERR_BAD_ANSWER	external request: sends back an error frame

Case of a read error:

Error Code	Error Name	Explanation
1	FGP_ERR_REQ_STACK_FULL	external request: sends back an error frame
3	FGP_ERR_REGISTER_NOT_FOUND	register not managed (or the request needs super user access rights)
4	FGP_ERR_ANSWER_DELAYED	external request: answer postponed
7	FGP_ERR_NOT_ALL_REGISTER_FOUND	one or both registers cannot be found

Registers Written by the Profibus Parameter Frame

Register List

Following registers are written by the Profibus parameter frame during the establishing of the cyclic data exchange in case a module with **R** for remote parameterization has been chosen:

TeSysU registers written during Profibus DP startup per TeSysU Variant	SCMu R MS	ScMu RMS PKW	ScMu R MMS	ScMu R MMS PKW	ScAD R MS	SCAD R MS PKW	ScSt R MS	ScSt R MS PKW
Control unit configuration	602	602	602	602	602	602	602	602
Control Unit communication on LUCM port address	603	603	603	603	-	-	-	-
Control Unit communication on LUCM baud rate	604	604	604	604	-	-	-	-
Overcurrent trip threshold	605	605	605	605	-	-	-	-
Loas class	606	606	606	606	-	-	-	-
Thermal reset time	607	607	607	607	-	-	-	-
Thermal reset threshold	608	608	608	608	-	-	-	-
Thermal warniong threshold	609	609	609	609	-	-	-	-
Ground fault trip timeout	610	610	610	610	-	-	-	-
Ground fault trip threshold	611	611	611	611	-	-	-	-
Ground fault warning threshold	612	612	612	612	-	-	-	-
Phase imbalance trip timeout at start-up	613	613	613	613	-	-	-	-
Phase imbalance trip timeoutwhile running	614	614	614	614	-	-	-	-
Phase imbalance trip threshold	615	615	615	615	-	-	-	-
Phase imbalance warning threshold	616	616	616	616	-	-	-	-
Jam trip timeout	617	617	617	617	-	-	-	-
Jam trip threshold	618	618	618	618	-	-	-	-
Jam warning threshold	619	619	619	619	-	-	-	-
Undercurrent trip timeout	620	620	620	620	-	-	-	-
Undercurrent trip threshold	621	621	621	621	-	-	-	-
Undercurrent warning threshold	622	622	622	622	-	-	-	-
Long start trip timeout	623	623	623	623	-	-	-	-
Long start trip threshold	624	624	624	624	-	-	-	-
Long start warning threshold	625	625	625	625	-	-	-	-
Control Unit display language	650	650	650	650	-	-	-	-
Control Unit display of running items	651	651	651	651	-	-	-	-
Control Unit full load amps setting	652	652	652	652	-	-	-	-
Communication loss fallback strategy	682	682	682	682	682	682	682	682
Inversion of output configuration	684	684	684	684	684	684	684	684
Output LO1 configuration	685	685	685	685	685	685	685	685
Output OA1 and OA3 configuration	686	686	686	686	686	686	686	686
Recovery Mode	688	688	688	688	688	688	688	688

NOTE: In case a module with "L" for local parameterization had been chosen the parameter frame on Profibus does not contain any application parameter at all.

Chapter 8

Configuration of Predefined Functions

Overtravel Limit Switch (Reflex Functions)

Introduction

Overtravel limit switch allows you to perform precise and iterative positionings, without any interaction of bus or PLC cycle time. It is a Profibus DP function initiated at LULC07 communication module level.

There are 2 types of functions:

- reflex1: "reflex stop no. 1" function
- reflex2: "reflex stop no. 2" function

Description of the "Reflex Stop No. 1" Function (Reflex1)

Sensor no. 1 (logic input LI1) directly controls motor stopping.

After a new run command (stop command then run command), the motor restarts even if something is still detected (LI1=1).

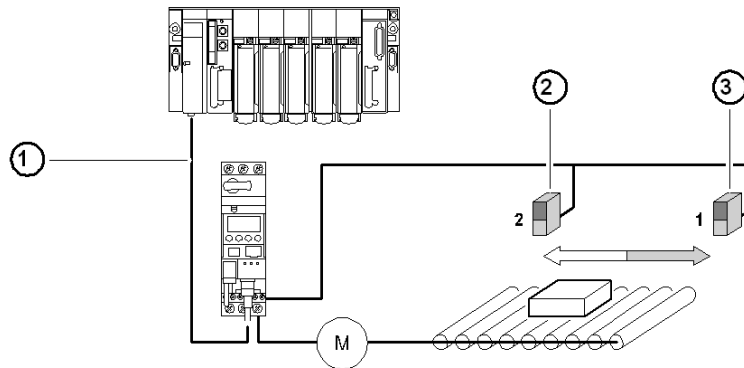

- 1 Bus
- 2 Sensor no. 2 (LI2)
- 3 Sensor no. 1 (LI1)

NOTE: In the case of a reversing starter, the reflex stop works in both directions. Sensor no. 2 (logic input LI2) has no effect on reflex operation.

Data sequence

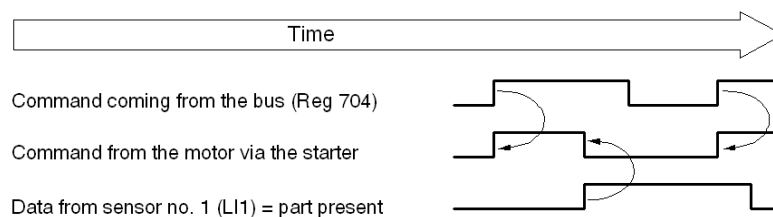

Description of the "Reflex Stop No. 2" Function (Reflex2)

Sensor no. 1 (logic input LI1) controls motor stopping in forward mode.

Sensor no. 2 (logic input LI2) controls motor stopping in reverse mode.

After a new run command (stop command then run command), the motor restarts even if something is still detected (LI1 or LI2 = 1).

NOTE: Sensor no. 2 (LI2) does not impact forward mode and sensor no. 1 (LI1) does not impact reverse mode.

Using a "Reflex Stop" Function

To use a "reflex stop" function, it must be selected in the register of the output to be monitored.

Reflex Function	Direction of Motor Rotation	LUB**/S** - LU2B**/2S** Base		Value of Reg•
		Output LO1	Outputs OA1 OA3	
Reflex1	Reflex1.Fw = forward	Reg685 (LSB) is part of the Profibus module parameter frame	Reg686 (LSB) (MSB) is part of the Profibus module parameter frame	8
	Reflex1.Rev = reverse			9
Reflex2	Reflex2.Fw = forward			10
	Reflex2.Rev = reverse			11

NOTE: Before using the "reflex stop" functions, outputs OA1/OA3 must first be assigned to the forward/reverse directions. This selection is made in register **686** (Register 686 is part of the Profibus DP module parameter frame). By default, OA1 is assigned to forward and OA3 to reverse.

Reflex1.Fw

This function is active on a rising edge (register 689.0 = 1) and not on the level.

- LI1 = 1, stops the motor irrespective of the chosen direction of operation
- After a new run command (stop command followed by a run command) even if logic input LI1 = 1 the motor restarts in the chosen direction

Register 689 is part of the Profibus DP module parameter frame.

NOTE: Logic input LI2 is not used.

Reflex1.Rev

This function is active on a rising edge (register 689.0 = 1) and not on the level.

- LI1 = 1, stops the motor irrespective of the chosen direction of operation
- after a new run command (stop command followed by a run command even if logic input LI1 = 1 the motor restarts in the chosen direction

Register 689 is part of the Profibus DP module parameter frame.

NOTE: Logic input LI2 is not used.

Reflex2.Fw

This function is active on a rising edge (register 689.0 = 1) and not on the level.

- logic input LI1 = 1, stops the motor in forward mode
logic input LI2 = 1, stops the motor in reverse mode
- after a new run command (stop command followed by a run command) even if logic input LI1 = 1 the motor restarts

Register 689 is part of the Profibus DP module parameter frame.

NOTE: Logic input LI2 does not impact forward mode and logic input LI1 does not impact reverse mode.

Reflex2.Rev

This function is active on a rising edge (register 689.0 = 1) and not on the level.

- logic input LI2 = 1, stops the motor in reverse mode
Logic input LI1 = 1, stops the motor in forward mode
- After a new run command (stop command followed by a run command) even if logic input LI2 = 1 the motor restarts

Register 689 is part of the Profibus DP module parameter frame.

NOTE: Logic input LI2 does not impact forward mode and logic input LI1 does not impact reverse mode.

Usability of Reflex with Profibus DP

The values described are transmitted only once via parameter frame at module startup. To use this functionality use acyclic services to access these registers when the slave is in data exchange mode. For details about acyclic services, see *Acyclic Data Read/Write via DP V1 and the PKW Feature*, [page 65](#).



A

- access to parameters, 39
- acknowledgment, 62
- acyclic accesses DP V0
 - PKW encapsulated, 68
- acyclic data read/write via DP V1, 65
- addressing, 16
- addressing with dip switches, 16
- application faults, 62
- application parameter settings, 35

B

- BF LED, 14

C

- characteristics, 25
- combinations of bases and control units, 31
- communication loss, 39
 - restart, 63
 - warnings, 63
- components assembly on a power base, 17
- conditions of use, 25, 25
- conductor, 20
- configuration
 - customizing, 39
 - factory, 38
- configuration via SyCon, 37
- configuring
 - output LO1, 41
 - output OA1, 41
 - output OA3, 41
- connecting the bus, 23
- connection, 18
- connection to the Profibus DP, 21, 21
- connector, 20
- connectors, 14
- control Unit
 - forcing, 42
- customizing control, 44
- customizing your configuration, 39
- cyclic/acyclic services, 30

D

- description and installation of the module, 14
- diagnostic telegram, 57
- dip switches addressing, 16
- DP V1
 - acyclic data read/write, 65
- DP V1 services, 30

E

- electrical connection, 18
- ERR LED, 14
- error codes
 - PKW, 69

F

- factory configuration, 38
- fallback mode, 39
- fault indicators, 60
- fault reset, 61
- faults
 - application, 62
 - internal, 64
 - reset, 61
 - viewing, 60
- faults and warnings
 - managing, 59
- features of Profibus DP, 24
- forcing
 - control unit, 42
- functions
 - reflex stop function, 73
- functions in general, 44
- functions offered, 13
- functions to set, 43

G

- general information
 - implementation via Profibus DP, 30
- GS*-file
 - modules presented, 31

H

- hardware implementation, 9

I

- implementation via Profibus DP, 33
 - general information, 30
- information
 - TeSys U specific Profibus, 29
- initialization, 34
- input, 14
- inputs, 26
- installation and description of the module, 14
- installation of the module, 11
- internal faults, 64
- invert output relays, 40

L

- LED, 14, 14
- LED 24V, 15
- light emitting diodes, 14
- limit switch
 - overtravel, 73
- link wire-to-wire, 19
- loss of communication, 39

M

- managing faults and warnings, 59

mode
 fallback, 39
module functions, 13

O

order of mounting, 17
output, 14
output LO1
 configuring, 41
output OA1
 configuring, 41
output OA3
 configuring, 41
outputs, 26
overtravel limit switch, 73

P

parameter settings
 application, 35, 39
parameters
 access to, 39
PKW data, 68
PKW error codes, 69
PKW feature, 30, 68
power base, 17
power base connection of terminals A1, A2, 19
power supplies, 18
power supply, 18, 25
power up, 18
presentation of the module, 13
Profibus DB, 21
Profibus DP
 application parameter settings, 35
Profibus DP
 general information on implementation, 29
Profibus DP
 implementation via, 33
Profibus DP configuration via the SyCon tool, 37
Profibus DP features, 24
Profibus DP implementation
 general information, 30
Profibus information
 TeSys U specific, 29
profiles
 functions for Profibus DP, 45
 motor management starter, 45
 motor starter, 45

R

read/write via DP V1
 acyclic data, 65
receiving the product, 13
recovery
 after loss of communication, 63
reflex stop function, 73
registers
 written by the Profibus parameter frame, 71
reset faults, 61

S

services
 cyclic/acyclic, 30
 DP V1, 30
software implementation, 27
specific information
 TeSys U Profibus, 29
status display, 44
SyCon configuration tool, 37

T

technical characteristics, 25
TeSys U specific Profibus information, 29
transmission features, 23

V

viewing a fault, 60

W

warning acknowledgment, 63
warnings
 communication loss, 63
warnings and faults
 managing, 59
wire-to-wire link, 19
write/read via DP V1
 acyclic data, 65



1672610EN-03

Schneider Electric Industries SAS

35, rue Joseph Monier
CS30323
F - 92506 Rueil Malmaison Cedex

www.schneider-electric.com

As standards, specifications and designs change from time to time, please ask for confirmation of the information given in this publication.

08/2019