

ComPacT NSX100-250

VigiPacT Add-on

VigiPacT Add-on Alarm

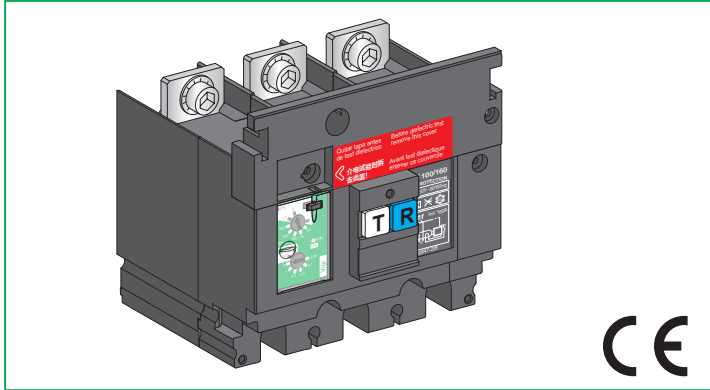

PHA60738

<p>PLEASE NOTE</p> <ul style="list-style-type: none"> ● Electrical equipment should be installed, operated, serviced, and maintained only by qualified personnel. ● No responsibility is assumed by Schneider Electric for any consequences arising out of the use of this material. 	<p>BITTE BEACHTEN</p> <ul style="list-style-type: none"> ● Elektrische Geräte dürfen nur von Fachpersonal installiert, betrieben, bedient und gewartet werden. ● Schneider Electric haftet nicht für Schäden, die durch die Verwendung dieses Materials entstehen.
<p>REMARQUE IMPORTANTE</p> <ul style="list-style-type: none"> ● L'installation, l'utilisation, la réparation et la maintenance des équipements électriques doivent être assurées uniquement par du personnel qualifié. ● Schneider Electric décline toute responsabilité quant aux conséquences de l'utilisation de ce matériel. 	<p>NOTA</p> <ul style="list-style-type: none"> ● Manutenzione, riparazione, installazione e uso delle apparecchiature elettriche si devono affidare solo a personale qualificato. ● Schneider Electric non si assume alcuna responsabilità per qualsiasi conseguenza derivante dall'uso di questo materiale.
<p>TENGA EN CUENTA</p> <ul style="list-style-type: none"> ● La instalación, manejo, puesta en servicio y mantenimiento de equipos eléctricos deberán ser realizados sólo por personal cualificado. ● Schneider Electric no se hace responsable de ninguna de las consecuencias del uso de este material. 	<p>NOTA</p> <ul style="list-style-type: none"> ● A instalação, utilização e manutenção do equipamento eléctrico devem ser efectuadas exclusivamente por pessoal qualificado. ● A Schneider Electric não assume qualquer responsabilidade pelas consequências resultantes da utilização deste material.
<p>请注意</p> <ul style="list-style-type: none"> ● 电气设备的安装、操作、维修和维护工作仅限于合格人员执行。 ● Schneider Electric 不承担由于使用本资料所引起的任何后果。 	<p>ОБРАТИТЕ ВНИМАНИЕ</p> <ul style="list-style-type: none"> ● Установка, эксплуатация, ремонт и обслуживание электрического оборудования может выполняться только квалифицированными электриками. ● Компания Schneider Electric не несет никакой ответственности за любые возможные последствия использования данной документации.

⚠️ DANGER / DANGER / PELIGRO / 危險 / GEFAHR / PERICOLO / PERIGO / ОПАСНОСТЬ

<p>HAZARD OF ELECTRIC SHOCK, EXPLOSION OR ARC FLASH</p> <ul style="list-style-type: none"> ● Apply appropriate personal protective equipment (PPE) and follow safe electrical work practices. See NFPA 70E, CSA Z462, NOM-029-STPS or local equivalent. ● This equipment must only be installed and serviced by qualified electrical personnel. ● Turn off all power supplying this equipment before working on or inside equipment. ● Always use a properly rated voltage sensing device to confirm power is off. ● Put back all devices, doors, and covers before turning on power to this equipment. ● Beware of potential hazards, and carefully inspect the work area for tools and objects that may have been left inside the equipment. <p>Failure to follow these instructions will result in death or serious injury.</p>	<p>RISQUE D'ÉLECTROCUTION, D'EXPLOSION OU D'ÉCLAIR D'ARC ÉLECTRIQUE</p> <ul style="list-style-type: none"> ● Portez un équipement de protection individuel (EPI) adapté et respectez les consignes de sécurité électrique courantes. Reportez-vous aux normes NFPA 70E, CSA Z462, NOM-029-STPS ou aux codes locaux en vigueur. ● Seul un personnel qualifié doit effectuer l'installation et l'entretien de cet équipement. ● Débranchez toutes les sources d'alimentation de cet équipement avant d'effectuer toute opération interne ou externe sur celui-ci. ● Utilisez toujours un dispositif de détection de tension ayant une valeur nominale appropriée pour vous assurer que l'alimentation est coupée. ● Remplacez tous les dispositifs, les portes et les capots avant de mettre l'équipement sous tension. ● Faites attention aux dangers potentiels et inspectez attentivement la zone de travail pour vous assurer qu'aucun outil ou objet n'est resté à l'intérieur de l'équipement. <p>Si ces directives ne sont pas respectées, cela entraînera la mort ou des blessures graves.</p>	<p>PELIGRO DE DESCARGA ELÉCTRICA, EXPLOSIÓN O DESTELLO POR ARQUEO</p> <ul style="list-style-type: none"> ● Utilice equipo de protección personal (EPP) apropiado y siga las prácticas de seguridad eléctricos establecidas. Consulte las normas NFPA 70E, CSA Z462, NOM-029-STPS u otros códigos locales correspondientes. ● Solamente el personal eléctrico calificado deberá instalar y prestar servicio de mantenimiento a este equipo. ● Desconecte todas las fuentes de alimentación del equipo antes de realizar cualquier trabajo en él. ● Siempre utilice un dispositivo detector de tensión nominal adecuado para confirmar la desenergización del equipo. ● Vuelva a colocar todos los dispositivos, las puertas y las cubiertas antes de volver a energizar el equipo. ● Tenga cuidado con los riesgos potenciales, e inspeccione cuidadosamente la zona de trabajo para comprobar si han quedado herramientas y objetos dentro del equipo. <p>El incumplimiento de estas instrucciones provocará lesiones graves o incluso la muerte.</p>	<p>电击、爆炸或弧闪的危险</p> <ul style="list-style-type: none"> ● 采用适当的个人防护设备 (PPE) 并遵循电气作业安全守则。请参阅 NFPA 70E, CSA Z462, NOM-029-STPS 或当地对应的标准。 ● 只有具备相应资质的电气人员才能安装和维修该设备。 ● 在该设备表面或内部工作之前, 请关闭设备的全部电源。 ● 确保使用合适的额定电压传感器确认电源已关闭。 ● 装回所有设备、门和盖, 然后再打开该设备的电源。 ● 注意潜在危险, 仔细检查作业区, 以免将工具和物件遗忘在设备内部。 <p>不遵循上述说明将导致人员伤亡。</p>
<p>GEFAHR VON ELEKTRISCHEM SCHLAG, EXPLOSION ODER LICHTBOGEN</p> <ul style="list-style-type: none"> ● Tragen Sie persönliche Schutzausrüstung (PSA) und befolgen Sie sichere Verfahren im Umgang mit Elektrogeräten. Siehe NFPA 70E, CSA Z462, NOM-029-STPS oder lokale Entsprechung. ● Diese Geräte dürfen nur von qualifizierten Elektrikern installiert und gewartet werden. ● Schalten Sie vor Arbeiten am bzw. im Innern des Geräts die gesamte Spannungsversorgung ab. ● Verwenden Sie für die Prüfung vorhandener Spannung stets einen Spannungsfühler mit zutreffender Bemessungsspannung. ● Bringen Sie alle Vorrichtungen, Türen und Abdeckungen wieder an, bevor Sie das Gerät einschalten. ● Beachten Sie potenzielle Gefahren, und überprüfen Sie den Arbeitsbereich auf Werkzeuge und andere Gegenstände, die sich möglicherweise noch in der Anlage befinden. <p>Die Nichtbeachtung dieser Anweisungen führt zu Tod oder schweren Verletzungen.</p>	<p>RISCHIO DI FOLGORAZIONE, ESPLOSIONI O ARCO ELETTRICO</p> <ul style="list-style-type: none"> ● Utilizzare dispositivi di protezione individuale (DPI) idonei e adottare misure di sicurezza adeguate per lavori elettrici. Vedere le normative NFPA 70E, CSA Z462, NOM-029-STPS o le norme equivalenti nel paese di installazione. ● Installazione e manutenzione di questa apparecchiatura si devono affidare solo ad elettricisti qualificati. ● Prima di lavorare con l'apparecchiatura o al suo interno isolare completamente l'alimentazione elettrica. ● Per verificare che l'alimentazione sia isolata usare sempre un rivelatore di tensione correttamente tarato. ● Sostituire dispositivi, sportelli e coperture prima di riaccendere l'alimentazione dell'apparecchiatura. ● Prestare attenzione a potenziali pericoli e ispezionare con attenzione l'area di lavoro per assicurarsi di non aver dimenticato utensili o altri oggetti all'interno dell'apparecchiatura. <p>Il mancato rispetto di queste istruzioni provocherà morte o gravi infortuni.</p>	<p>RISCO DE ELECTROCUSSÃO, DE EXPLOSIÃO, OU DE ARCO ELÉCTRICO</p> <ul style="list-style-type: none"> ● Utilize equipamento de protecção pessoal (PPE) e siga os métodos de segurança eléctrica. Consulte NFPA 70E, CSA Z462, NOM-029-STPS ou o equivalente local. ● A instalação e manutenção deste equipamento só devem ser efectuadas por electricistas qualificados. ● Desligue todas as fontes de alimentação deste equipamento antes de trabalhar no equipamento ou no seu interior. ● Utilize sempre um dispositivo de detecção da tensão nominal adequada para confirmar se a alimentação está desligada. ● Substitua todos os dispositivos, portas e tampas antes de ligar a alimentação deste equipamento. ● Esteja atento a potenciais perigos e inspeccione cuidadosamente a área de trabalho para se assegurar que não foram deixadas ferramentas e objects no interior do equipamento. <p>A não observância destas instruções resultará em morte, ou ferimentos graves.</p>	<p>Опасность поражения электрическим током, взрыва или возникновения дуги</p> <ul style="list-style-type: none"> ● Используйте подходящие средства индивидуальной защиты (СИЗ) и соблюдайте технику безопасности при электротехнических работах. См. NFPA 70E, CSA Z462, NOM-029-STPS или местный эквивалентный стандарт. ● Данное оборудование могут устанавливать и обслуживать только квалифицированные электрики. ● Отключите питание до начала работы снаружи или внутри оборудования. ● Всегда пользуйтесь надлежащим датчиком номинального напряжения для определения отсутствия питания. ● Установите обратно все устройства, дверцы и крышки перед включением питания данного оборудования. ● Избегайте потенциальных опасностей, внимательно осмотрите рабочую область на наличие инструментов и предметов, которые могли остаться внутри оборудования. <p>Несоблюдение этих инструкций приведет к смерти или серьезной травме.</p>

PHA6073803-00



**▲ WARNING / AVERTISSEMENT / ADVERTENCIA / 警告 /
WARNUNG / AVVERTIMENTO / ATENÇÃO / ПРЕДУПРЕЖДЕНИЕ**

<p>ABSENCE OF EARTH-LEAKAGE PROTECTION Do not use VigiPacT Add-on Alarm to protect your equipment against earth-leakage faults. These trip units only indicate the presence of an earth-leakage fault. Failure to follow these instructions can result in death, serious injury, or equipment damage.</p>	<p>ABSENCE DE PROTECTION DIFFERENTIELLE N'utilisez pas les VigiPacT Add-on Alarm pour protéger votre équipement en cas de courant de fuite à la terre. Ils signalent uniquement la présence de courant de fuite à la terre. Si ces directives ne sont pas respectées, cela peut entraîner la mort ou des blessures graves ou des dommages matériels.</p>	<p>FALTA DE PROTECCIÓN DIFERENCIAL No use VigiPacT add-on Alarm para proteger su equipo contra fallos de protección diferencial. Estas unidades de control solo indican la presencia de un fallo de protección diferencial. El incumplimiento de estas instrucciones puede causar la muerte, lesiones serias o daño al equipo.</p>	<p>缺失接地泄漏保护 不得使用 VigiPacT add-on Alarm 来为您的设备提供接地漏电故障保护。这些脱扣单元仅指示接地漏电故障的存在。 不遵循上述说明可能导致人员伤亡或设备损坏。</p>
<p>KEINE FEHLERSTROMSCHUTZVORRICHTUNG VORHANDEN Der VigiPacT add-on Alarm darf keinesfalls als Fehlerstromschutzvorrichtung für Ihre Anlage eingesetzt werden. Diese Auslöseeinheiten dienen lediglich der Signalisierung eines Erdschlussfehlers. Die Nichtbeachtung dieser Anweisungen kann Tod, schwere Verletzungen oder Sachschäden zur Folge haben.</p>	<p>ASSENZA DI PROTEZIONE DA DISPERSIONE DI TERRA Non utilizzare VigiPacT Add-on Alarm per proteggere l'apparecchiatura da guasti di dispersione a terra. Tali unità di sgancio indicano solo la presenza di un guasto di dispersione a terra. Il mancato rispetto di queste istruzioni può provocare morte, gravi infortuni o danni alle apparecchiature.</p>	<p>AUSÊNCIA DE PROTEÇÃO DIFERENCIAL Não use o VigiPacT add-on Alarm para proteger seu equipamento contra falhas de aterramento. Essas unidades de disparo indicam somente a presença de falha de vazamento de aterramento. A não observância destas instruções pode provocar a morte, ferimentos graves, ou danos no equipamento.</p>	<p>ОТСУТСТВИЕ ЗАЩИТЫ ОТ УТЕЧКИ НА ЗЕМЛЮ Не используйте VigiPacT add-on Alarm для защиты оборудования от отказов по утечке на землю. Данные размыкатели только указывают на отказ по утечке на землю. Несоблюдение этих инструкций может привести к смерти, серьезной травме или повреждению оборудования.</p>

NOTICE / AVIS / AVISO / 注意 / HINWEIS / AVVISO / AVISO / УВЕДОМЛЕНИЕ

<p>HAZARD OF DEVICE DETERIORATION ● Do not mount VigiPacT Add-on if the network voltage is greater than 550 V~ 50/60 Hz. ● Do not mount VigiPacT Add-on Alarm if the network voltage is greater than 440 V~ 50/60 Hz. Failure to follow these instructions can result in equipment damage.</p>	<p>RISQUE DE DÉTERIORATION DE L'APPAREIL ● Ne montez pas le VigiPacT Add-on si la tension du réseau est supérieure à 550 V~ 50/60 Hz. ● Ne montez pas le VigiPacT Add-on Alarm si la tension du réseau est supérieure à 440 V~ 50/60 Hz. Si ces directives ne sont pas respectées, cela peut entraîner des dommages matériels.</p>	<p>RIESGO DE DETERIORO DEL DISPOSITIVO ● No monte VigiPacT Add-on si la tensión de red es mayor que 550 V~, 50/60 Hz. ● No monte VigiPacT Add-on Alarm si la tensión de red es mayor que 440 V~, 50/60 Hz. El incumplimiento de estas instrucciones puede causar daño al equipo.</p>	<p>设备性能退化风险 ● 如果网络电压大于 550 V~ 50/60 Hz, 不得安装 VigiPacT Add-on。 ● 如果网络电压大于 440 V~ 50/60 Hz, 不得安装 VigiPacT Add-on Alarm。 不遵循上述说明可能导致设备损坏。</p>
<p>GEFAHR EINER BESCHÄDIGUNG DES GERÄTS ● Montieren Sie das VigiPacT Add-on nicht, wenn die Netzwerkspannung mehr als 550 V~ 50/60 Hz beträgt. ● Montieren Sie den VigiPacT Add-on Alarm nicht, wenn die Netzwerkspannung mehr als 440 V~ 50/60 Hz beträgt. Die Nichtbeachtung dieser Anweisungen kann Sachschäden zur Folge haben.</p>	<p>PERICOLO DI DETERIORAMENTO DEL DISPOSITIVO ● Non montare VigiPacT Add-on se la tensione di rete è maggiore di 550 V~ 50/60 Hz. ● Non montare VigiPacT Add-on Alarm se la tensione di rete è maggiore di 440 V~ 50/60 Hz. Il mancato rispetto di queste istruzioni può provocare danni alle apparecchiature.</p>	<p>PERIGO DE DETERIOÇÃO DO DISPOSITIVO ● Não monte o VigiPacT Add-on se a tensão da rede for superior a 550 V~ 50/60 Hz. ● Não monte o VigiPacT Add-on Alarm se a tensão da rede for superior a 440 V~ 50/60 Hz. A não observância destas instruções pode provocar danos no equipamento.</p>	<p>ОПАСНОСТЬ УХУДШЕНИЯ ХАРАКТЕРИСТИК УСТРОЙСТВА ● Не устанавливайте VigiPacT Add-on, если напряжение в сети превышает 550 В пер. тока, 50/60 Гц. ● Не устанавливайте VigiPacT Add-on Alarm, если напряжение в сети превышает 440 В пер. тока, 50/60 Гц. Несоблюдение этих инструкций может привести к повреждению оборудования.</p>

PHA6073801

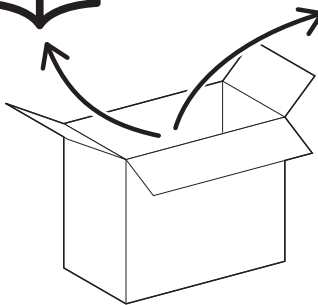

3P

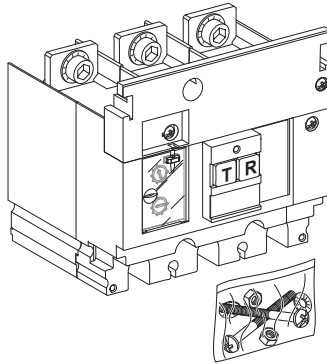

4P

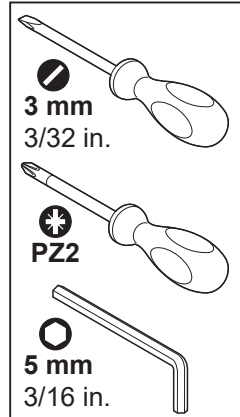
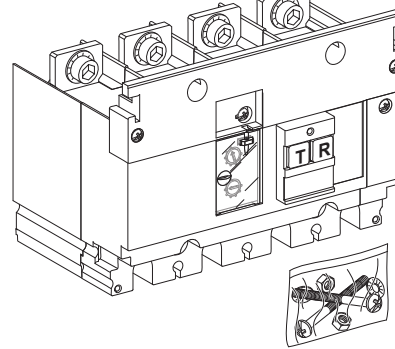

VigiPacT Add-on	3P	4P
200–440 V~ (NSX100/160)	LV429488	LV429489
440–550 V~ (NSX100/160)	LV429490	LV429491
200–440 V~ (NSX250)	LV429492	LV429493
440–550 V~ (NSX250)	LV429494	LV429495
550 V~ RSA (NSX250)	LV429496	–

VigiPacT Add-on Alarm	3P	4P
200–440 V~ (NSX100/160/250)	LV429498	LV429499

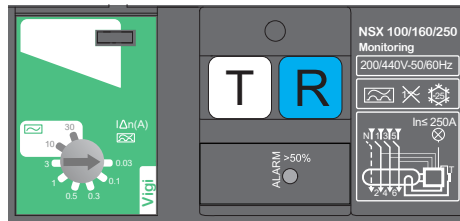
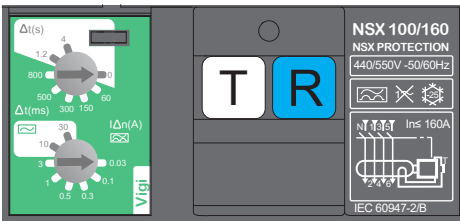

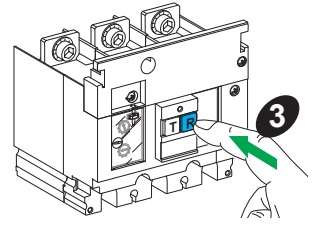
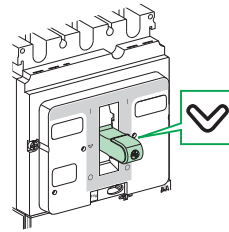
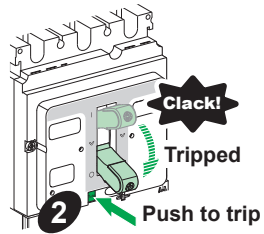
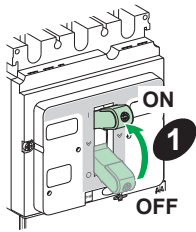

mm
in.

3P

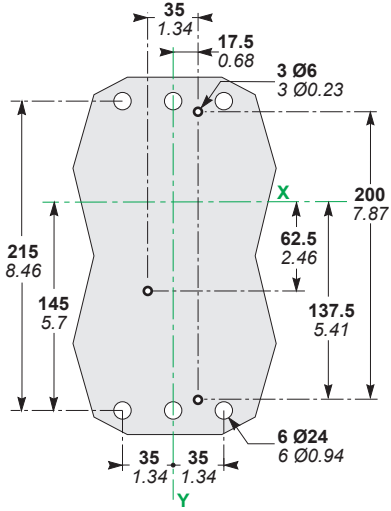
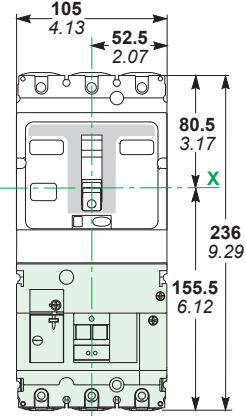

3P/4P

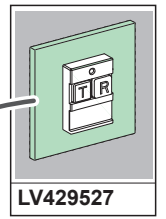
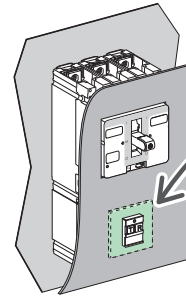

4P

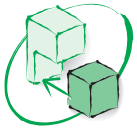
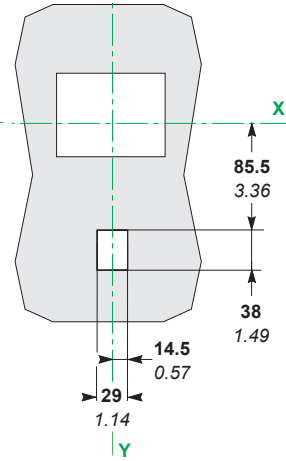
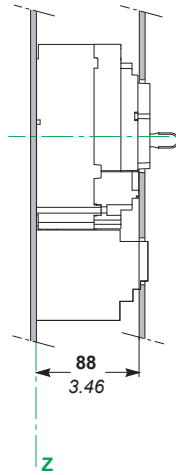
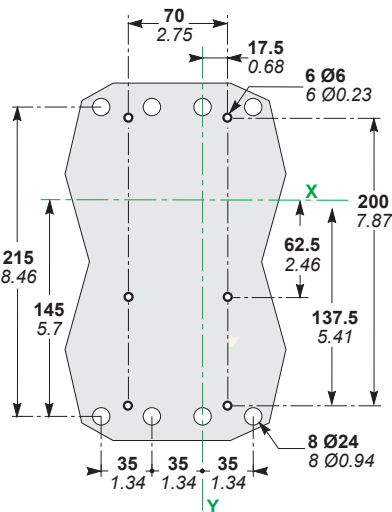
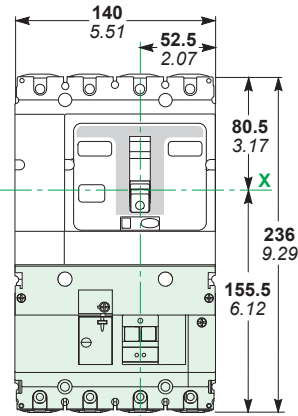

NSX160/250

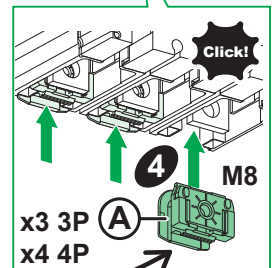
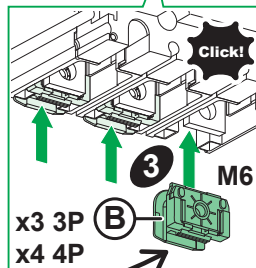
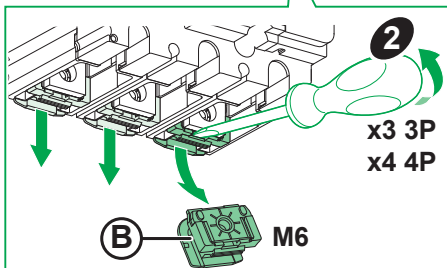
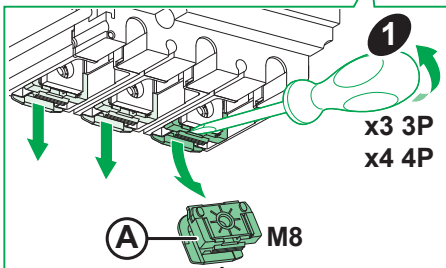
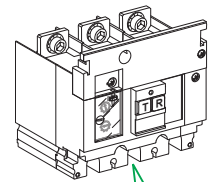
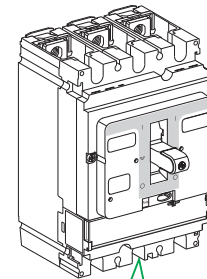
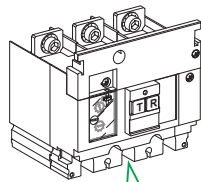
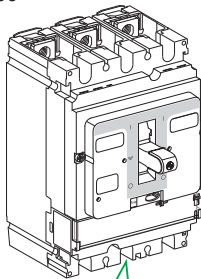

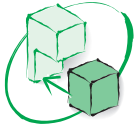

⚠️ ⚠️ DANGER / DANGER / PELIGRO / 危險 / GEFAHR / PERICOLO / PERIGO / ОПАСНОСТЬ

<p>HAZARD OF ELECTRIC SHOCK, EXPLOSION OR ARC FLASH If the network voltage is greater than 440 V~, it is mandatory to install an insulation accessory. Failure to follow these instructions will result in death or serious injury.</p>	<p>RISQUE D'ÉLECTROCUTION, D'EXPLOSION OU D'ÉCLAIR D'ARC ÉLECTRIQUE Si la tension du réseau est supérieure à 440 V~, il est obligatoire de monter un accessoire d'isolement. Si ces directives ne sont pas respectées, cela entraînera la mort ou des blessures graves.</p>	<p>PELIGRO DE DESCARGA ELÉCTRICA, EXPLOSIÓN O DESTELLO POR ARQUEO Si la tensión de red es de más de 440 V~, es obligatorio instalar un accesorio de aislamiento. El incumplimiento de estas instrucciones provocará lesiones graves o incluso la muerte.</p>	<p>电击、爆炸或弧闪的危险 如果电网电压大于 440 V~, 必须安装绝缘附件。 不遵循上述说明将导致人员伤亡。</p>
<p>GEFAHR VON ELEKTRISCHEM SCHLAG, EXPLOSION ODER LICHTBOGEN Bei Netzwerkspannungen über 440 V~ ist es zwingend erforderlich, Isolationszubehör zu installieren. Die Nichtbeachtung dieser Anweisungen führt zu Tod oder schweren Verletzungen.</p>	<p>RISCHIO DI FOLGORAZIONE, ESPLOSIONI O ARCO ELETTRICO Se la tensione di rete è superiore a 440 V~, è obbligatorio installare un accessorio di isolamento. Il mancato rispetto di queste istruzioni provocherà morte o gravi infortuni.</p>	<p>RISCO DE ELECTROCUSÃO, DE EXPLOSIÃO, OU DE ARCO ELÉTRICO Se a tensão da rede for superior a 440 V~, é obrigatório instalar um acessório de isolamento. A não observância destas instruções resultará em morte, ou ferimentos graves.</p>	<p>ОПАСНОСТЬ ПОРАЖЕНИЯ ЭЛЕКТРИЧЕСКИМ ТОКОМ, ВЗРЫВА ИЛИ ВОЗНИКНОВЕНИЯ ДУГИ Если сетевое напряжение превышает 440 В~, обязательно установите изоляционную принадлежность. Несоблюдение этих инструкций приведет к смерти или серьезной травме.</p>

⚠️ WARNING / AVERTISSEMENT / ADVERTENCIA / 警告 / WARNUNG / AVVERTIMENTO / ATENÇÃO / ПРЕДУПРЕЖДЕНИЕ

<p>HAZARD OF NON-TRIPPING Do not install VigiPacT Add-on and VigiPacT Add-on Alarm in the following configurations: ● upstream of the circuit breaker ● downstream of PowerTag M250 ● downstream of an LV429358 or LV429359 coupling accessory. Failure to follow these instructions can result in death, serious injury, or equipment damage.</p>	<p>RISQUE DE NON-DECLenchEMENT N'installez pas les VigiPacT Add-on et VigiPacT Add-on Alarm dans les configurations suivantes : ● en amont du disjoncteur ● en aval du PowerTag M250 ● en aval d'un accessoire de couplage LV429358 ou LV429359. Si ces directives ne sont pas respectées, cela peut entraîner la mort ou des blessures graves ou des dommages matériels.</p>	<p>RIESGO DE AUSENCIA DE DISPARO No instale VigiPacT Add-on y VigiPacT Add-on Alarm en las siguientes configuraciones: ● Aguas arriba del interruptor automático. ● Aguas abajo del PowerTag M250. ● Aguas abajo de un accesorio de acoplamiento LV429358 o LV429359. El incumplimiento de estas instrucciones puede causar la muerte, lesiones serias o daño al equipo.</p>	<p>不脱扣的风险 不得在以下位置安装 VigiPacT Add-on 和 VigiPacT Add-on Alarm: ● 断路器上游 ● PowerTag M250 下游 ● LV429358 或 LV429359 连接附件的下游。 不遵循上述说明可能导致人员伤亡或设备损坏。</p>
<p>GEFAHR DES NICHTAUSLÖSENS Der VigiPacT Add-on und der VigiPacT Add-on Alarm dürfen nicht in folgenden Konfigurationen installiert werden: ● vor dem Leistungsschalter ● hinter dem PowerTag M250 ● hinter dem Kopplungszubehör LV429358 oder LV429359. Die Nichtbeachtung dieser Anweisungen kann Tod, schwere Verletzungen oder Sachschäden zur Folge haben.</p>	<p>PERICOLO DI MANCATO SGANCIO Non installare VigiPacT Add-on e VigiPacT Add-on Alarm nelle configurazioni seguenti: ● a monte dell'interruttore ● a valle di PowerTag M250 ● a valle di un accessorio di accoppiamento LV429358 o LV429359. Il mancato rispetto di queste istruzioni può provocare morte, gravi infortuni o danni alle apparecchiature.</p>	<p>PERIGO DE NÃO DISPARO Não instale VigiPacT Add-on e VigiPacT Add-on Alarm nas seguintes configurações: ● a montante do disjuntor ● a jusante do PowerTag M250 ● a jusante de um acessório de acoplamento LV429358 ou LV429359. A não observância destas instruções pode provocar a morte, ferimentos graves, ou danos no equipamento.</p>	<p>ОПАСНОСТЬ НЕСРАБАТЫВАНИЯ Не устанавливайте VigiPacT Add-on и VigiPacT Add-on Alarm в следующих конфигурациях: ● перед автоматическим выключателем; ● после PowerTag M250; ● после соединительной принадлежности LV429358 или LV429359. Несоблюдение этих инструкций может привести к смерти, серьезной травме или повреждению оборудования.</p>



VigiPacT Add-on
VigiPacT Add-on Alarm

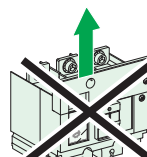
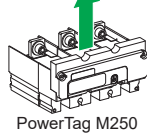
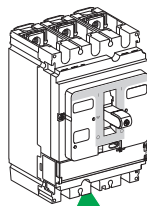
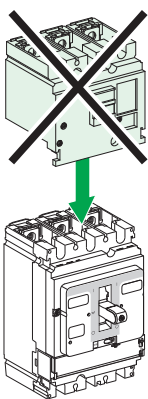

VigiPacT Add-on
VigiPacT Add-on Alarm

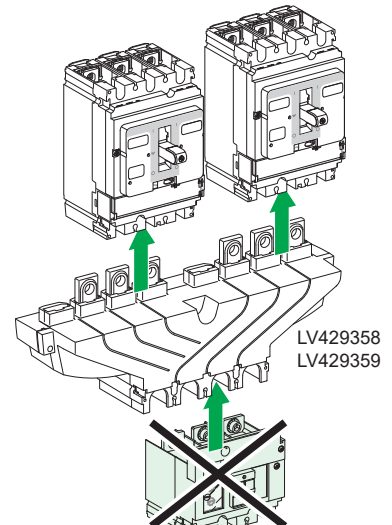

VigiPacT Add-on
VigiPacT Add-on Alarm

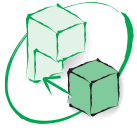

**⚠ WARNING / AVERTISSEMENT / ADVERTENCIA / 警告 /
WARNUNG / AVVERTIMENTO / ATENÇÃO / ПРЕДУПРЕЖДЕНИЕ**

<p>HAZARD OF FIRE Do not install VigiPacT Add-on and VigiPacT Add-on Alarm in the following configurations:</p> <ul style="list-style-type: none"> ● upstream of an LV429358 or LV429359 coupling accessory ● downstream of a ComPacT NSX circuit breaker associated with a ComPacT INS/INV switch-disconnector. <p>Failure to follow these instructions can result in death, serious injury, or equipment damage.</p>	<p>RISQUE D'INCENDIE N'installez pas les VigiPacT Add-on et VigiPacT Add-on Alarm dans les configurations suivantes :</p> <ul style="list-style-type: none"> ● en amont d'un accessoire de couplage LV429358 ou LV429359 ● en aval d'un disjoncteur ComPacT NSX associé à un interrupteur-sectionneur ComPacT INS/INV. <p>Si ces directives ne sont pas respectées, cela peut entraîner la mort ou des blessures graves ou des dommages matériels.</p>	<p>RIESGO DE INCENDIO No instale VigiPacT Add-on y VigiPacT Add-on Alarm en las siguientes configuraciones:</p> <ul style="list-style-type: none"> ● Aguas arriba de un accesorio de acoplamiento LV429358 o LV429359. ● Aguas abajo de un interruptor automático ComPacT NSX asociado a un interruptor en carga ComPacT INS/INV. <p>El incumplimiento de estas instrucciones puede causar la muerte, lesiones serias o daño al equipo.</p>	<p>火灾危险 不得在以下位置安装 VigiPacT Add-on 和 VigiPacT Add-on Alarm:</p> <ul style="list-style-type: none"> ● LV429358 或 LV429359 连接附件的上游 ● 与 ComPacT INS/INV 隔离开关配套的 ComPacT NSX 断路器的下游。 <p>不遵循上述说明可能导致人员伤亡或设备损坏。</p>
<p>BRANDGEFAHR Der VigiPacT Add-on und der VigiPacT Add-on Alarm dürfen nicht in folgenden Konfigurationen installiert werden:</p> <ul style="list-style-type: none"> ● vor dem Kopplungszubehör LV429358 oder LV429359 ● hinter einem mit einem Lasttrennschalter ComPacT INS/INV verbundenen Leistungsschalter ComPacT NSX <p>Die Nichtbeachtung dieser Anweisungen kann Tod, schwere Verletzungen oder Sachschäden zur Folge haben.</p>	<p>RISCHIO DI INCENDIO Non installare VigiPacT Add-on e VigiPacT Add-on Alarm nelle configurazioni seguenti:</p> <ul style="list-style-type: none"> ● a monte di un accessorio di accoppiamento LV429358 o LV429359 ● a valle di un interruttore ComPacT NSX associato a un interruttore di manovra-sezionatore ComPacT INS/INV. <p>Il mancato rispetto di queste istruzioni può provocare morte, gravi infortuni o danni alle apparecchiature.</p>	<p>PERIGO DE INCÊNDIO Não instale VigiPacT Add-on e VigiPacT Add-on Alarm nas seguintes configurações:</p> <ul style="list-style-type: none"> ● a montante de um acessório de acoplamento LV429358 ou LV429359 ● a jusante do disjuntor ComPacT NSX associado a um interruptor-seccionador ComPacT INS/INV. <p>A não observância destas instruções pode provocar a morte, ferimentos graves, ou danos no equipamento.</p>	<p>РИСК ВОЗНИКНОВЕНИЯ ПОЖАРА Не устанавливайте VigiPacT Add-on и VigiPacT Add-on Alarm в следующих конфигурациях:</p> <ul style="list-style-type: none"> ● перед соединительной принадлежностью LV429358 или LV429359; ● после автоматического выключателя ComPacT NSX, связанного с выключателем-разъединителем ComPacT INS/INV. <p>Несоблюдение этих инструкций может привести к смерти, серьезной травме или повреждению оборудования.</p>

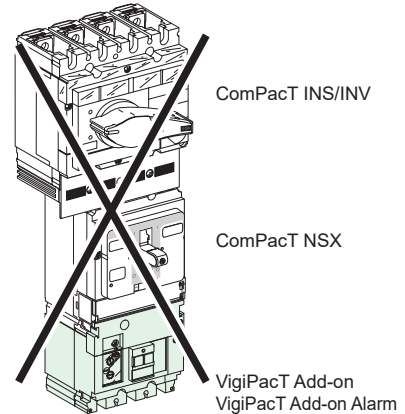
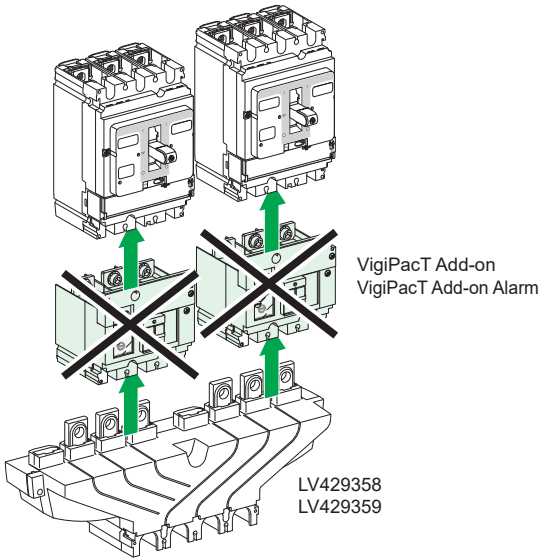



**▲ WARNING / AVERTISSEMENT / ADVERTENCIA / 警告 /
WARNUNG / AVVERTIMENTO / ATENÇÃO / ПРЕДУПРЕЖДЕНИЕ**

<p>HAZARD OF NON-TRIPPING Reset VigiPacT before installation. Failure to follow these instructions can result in death, serious injury, or equipment damage.</p>	<p>RISQUE DE NON-DECLenchEMENT Réarmez le VigiPacT avant son installation. Si ces directives ne sont pas respectées, cela peut entraîner la mort ou des blessures graves ou des dommages matériels.</p>	<p>RIESGO DE AUSENCIA DE DISPARO Restablezca VigiPacT antes de la instalación. El incumplimiento de estas instrucciones puede causar la muerte, lesiones serias o daño al equipo.</p>	<p>不脱扣的风险 安装前, 先复位 VigiPacT。 不遵循上述说明可能导致人员伤亡或设备损坏。</p>
<p>GEFAHR DES NICHTAUSLÖSENS Der VigiPacT muss vor der Installation zurückgesetzt werden. Die Nichtbeachtung dieser Anweisungen kann Tod, schwere Verletzungen oder Sachschäden zur Folge haben.</p>	<p>PERICOLO DI MANCATO SGANCIO Azzerare VigiPacT prima dell'installazione. Il mancato rispetto di queste istruzioni può provocare morte, gravi infortuni o danni alle apparecchiature.</p>	<p>PERIGO DE NÃO DISPARO Reinicie o VigiPacT antes da instalação. A não observância destas instruções pode provocar a morte, ferimentos graves, ou danos no equipamento.</p>	<p>ОПАСНОСТЬ НЕСРАБАТЫВАНИЯ Произведите сброс VigiPacT перед установкой. Несоблюдение этих инструкций может привести к смерти, серьезной травме или повреждению оборудования.</p>

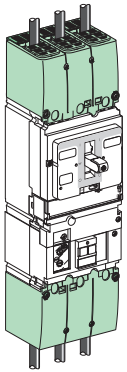

<p>en To connect and insulate the device, consult the instruction sheet NNZ4765407.</p>	<p>fr Pour raccorder et isoler l'appareil, consultez la notice de montage NNZ4765407.</p>	<p>es Para conectar y aislar el dispositivo, consulte la hoja de instrucciones NNZ4765407.</p>	<p>zh 如要连接和隔离设备, 请参阅说明书 NNZ4765407。</p>
<p>de Informationen zu Anschluss und Isolierung des Geräts finden Sie in der Kurzanleitung NNZ4765407.</p>	<p>it Per collegare e isolare il dispositivo, consultare la scheda di istruzioni NNZ4765407.</p>	<p>pt Para ligar e isolar o dispositivo, consulte a ficha de instruções NNZ4765407.</p>	<p>ru Порядок подключения и изоляции устройства см. в буклете с инструкциями NNZ4765407.</p>

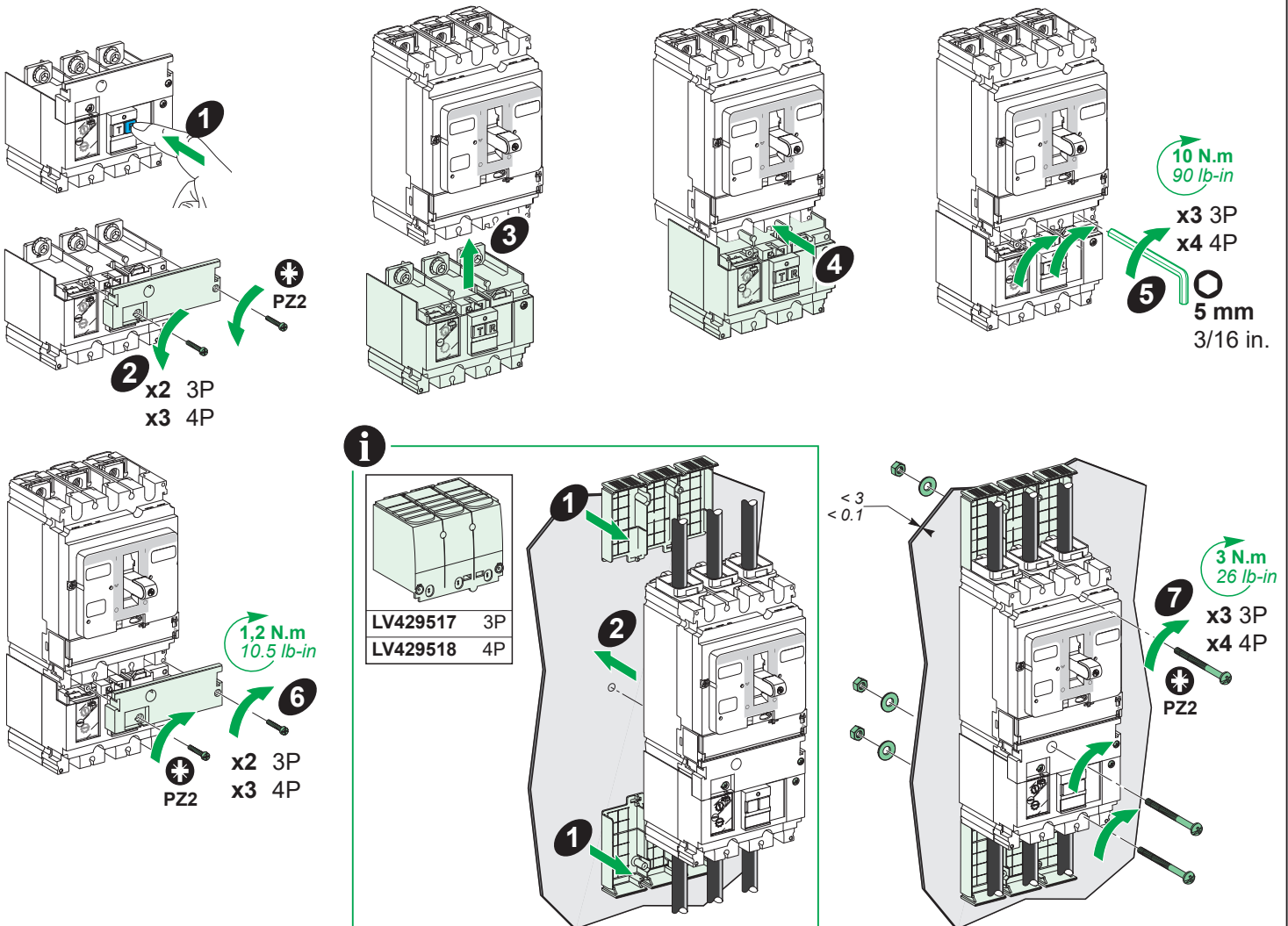

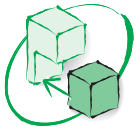

⚠️ ⚠️ DANGER / DANGER / PELIGRO / 危險 / GEFAHR / PERICOLO / PERIGO / ОПАСНОСТЬ

<p>HAZARD OF ELECTRIC SHOCK, EXPLOSION OR ARC FLASH For the plug-in base version, it is mandatory to mount short terminal shields LV429515 or LV429516 on the circuit breaker and the VigiPacT. Failure to follow these instructions will result in death or serious injury.</p>	<p>RISQUE D'ÉLECTROCUTION, D'EXPLOSION OU D'ÉCLAIR D'ARC ÉLECTRIQUE Pour la version débrochable sur socle, il est obligatoire de monter les cache-bornes courts LV429515 ou LV429516 sur le disjoncteur et le VigiPacT. Si ces directives ne sont pas respectées, cela entraînera la mort ou des blessures graves.</p>	<p>PELIGRO DE DESCARGA ELÉCTRICA, EXPLOSIÓN O ARCO ELÉCTRICO En la versión de zócalo de desconexión, es obligatorio montar los cubrebornes cortos LV429515 o LV429516 en el interruptor automático y VigiPacT. El incumplimiento de estas instrucciones provocará lesiones graves o incluso la muerte.</p>	<p>存在触电、爆炸或者电弧灼伤的危险 对于插入式底座版本，必须在断路器和 VigiPacT 上安装短端子屏罩 LV429515 或 LV429516。 不遵循上述说明将导致人员伤亡。</p>
<p>GEFAHR VON ELEKTRISCHEM SCHLAG, EXPLOSION ODER LICHTBOGEN Bei der Plug-In-Basis-Version müssen die kurzen Anschlussklemmen LV429515 oder LV429516 am Leistungsschalter und am VigiPacT montiert werden. Die Nichtbeachtung dieser Anweisungen führt zu Tod oder schweren Verletzungen.</p>	<p>RISCHIO DI FOLGORAZIONE, ESPLOSIONI O ARCO ELETTRICO Per la versione a base plug-in, è obbligatorio montare gli schermi di protezione morsetti corti LV429515 o LV429516 sull'interruttore e VigiPacT. Il mancato rispetto di queste istruzioni provocherà morte o gravi infortuni.</p>	<p>RISCO DE ELECTROCUSSÃO, DE EXPLOSÃO, OU DE ARCO ELÉCTRICO Para a versão básica do plug-in, é obrigatório montar blindagens terminais curtas LV429515 ou LV429516 no disjuntor e no VigiPacT. A não observância destas instruções resultará em morte, ou ferimentos graves.</p>	<p>ОПАСНОСТЬ ПОРАЖЕНИЯ ЭЛЕКТРИЧЕСКИМ ТОКОМ, ВЗРЫВА ИЛИ ВОЗНИКНОВЕНИЯ ДУГИ Для версии со штепсельным основанием обязательно необходимо установить короткие изоляторы клемм LV429515 или LV429516 на автоматический выключатель и VigiPacT. Несоблюдение этих инструкций приведет к смерти или серьезной травме.</p>

<p>en To install, connect and insulate the device, consult the relevant instruction sheet.</p>	<p>fr Pour installer, raccorder et isoler l'appareil, consultez la notice de montage correspondante.</p>	<p>es Para instalar, conectar y aislar el dispositivo, consulte la hoja de instrucciones pertinente.</p>	<p>zh 如要安装、连接和隔离设备，请参阅相关说明书。</p>
<p>de Informationen zu Installation, Anschluss und Isolierung des Geräts finden Sie in der zugehörigen Kurzanleitung.</p>	<p>it Per installare, collegare e isolare il dispositivo, consultare la scheda di istruzioni pertinente.</p>	<p>pt Para instalar, ligar e isolar o dispositivo, consulte a ficha de instruções relevante.</p>	<p>ru Порядок установки, подключения и изоляции устройства см. в соответствующем буклете с инструкциями.</p>

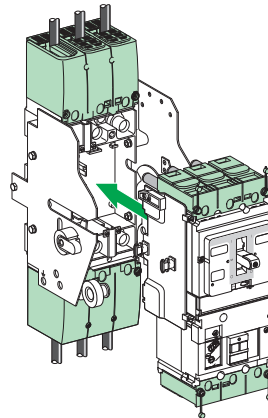
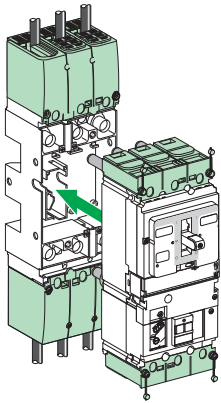

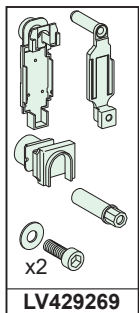
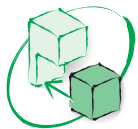

- en Plug-in base
- fr Débrochable sur socle
- es Zócalo de desconexión
- zh 插入式底座
- de Plug-In-Basis
- it Base plug-in
- pt Base de plug-in
- ru Штепсельное основание

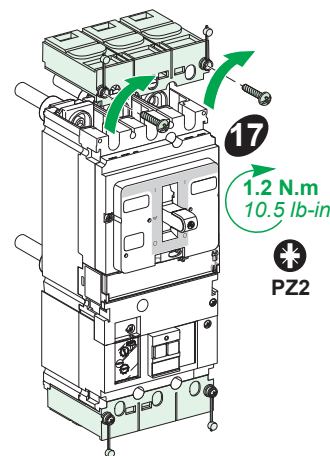
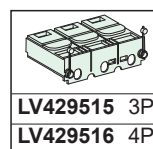
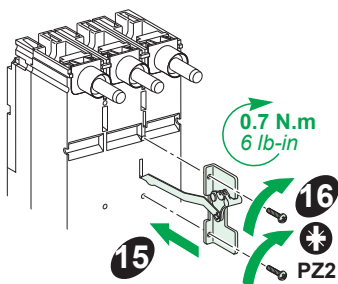
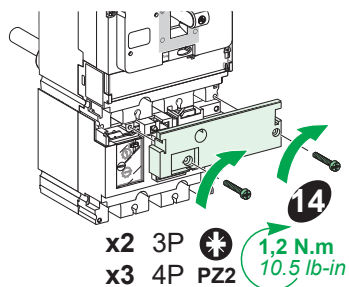
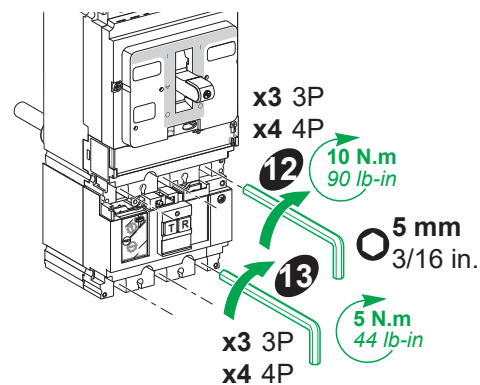
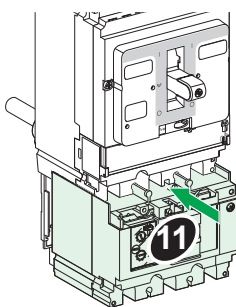
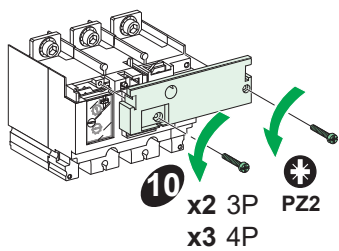
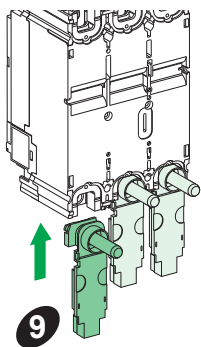
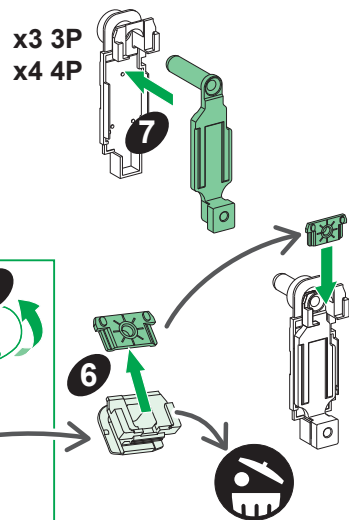
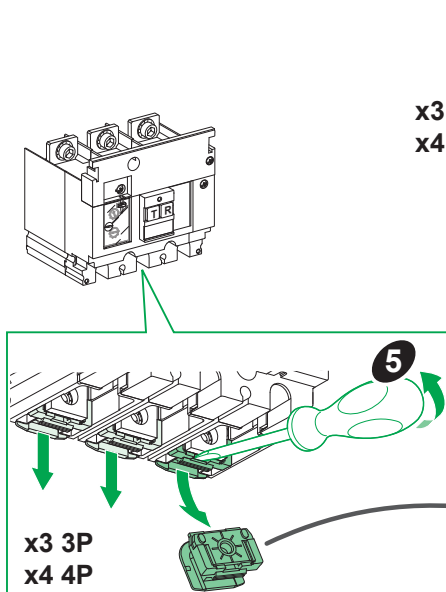
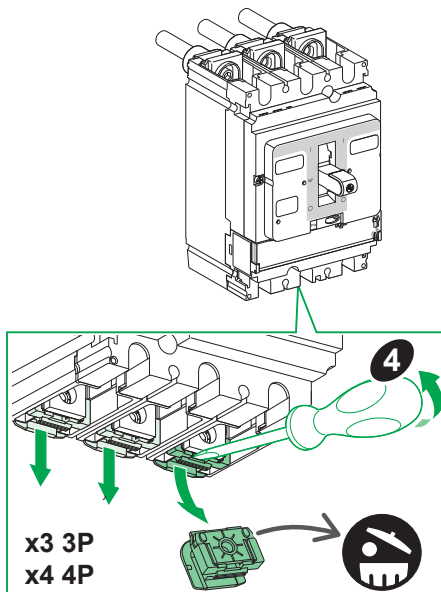
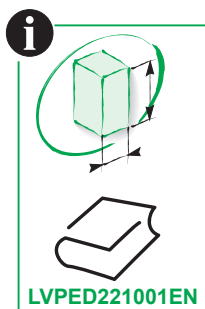
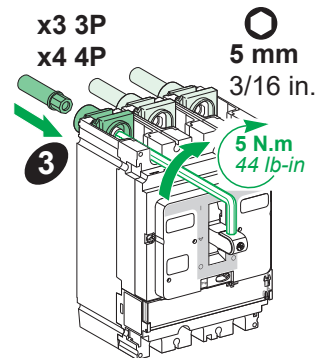
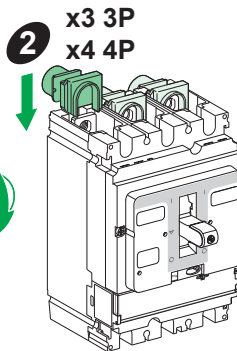
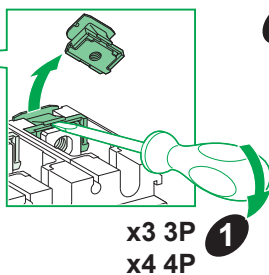
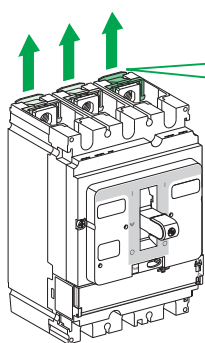

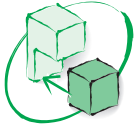

⚠️ DANGER / DANGER / PELIGRO / 危險 / GEFAHR / PERICOLO / PERIGO / ОПАСНОСТЬ

<p>HAZARD OF ELECTRIC SHOCK, EXPLOSION OR ARC FLASH For the plug-in base version, it is mandatory to mount short terminal shields LV429515 or LV429516 on the circuit breaker. Failure to follow these instructions will result in death or serious injury.</p>	<p>RISQUE D'ÉLECTROCUTION, D'EXPLOSION OU D'ÉCLAIR D'ARC ÉLECTRIQUE Pour la version débrochable sur socle, il est obligatoire de monter les cache-bornes courts LV429515 ou LV429516 sur le disjoncteur. Si ces directives ne sont pas respectées, cela entraînera la mort ou des blessures graves.</p>	<p>PELIGRO DE DESCARGA ELÉCTRICA, EXPLOSIÓN O ARCO ELÉCTRICO En la versión de zócalo de desconexión, es obligatorio montar los cubrebornes cortos LV429515 o LV429516 en el interruptor automático. El incumplimiento de estas instrucciones provocará lesiones graves o incluso la muerte.</p>	<p>存在触电、爆炸或者电弧灼伤的危险 对于插入式底座版本，必须在断路器上安装短端子屏障 LV429515 或 LV429516。 不遵循上述说明将导致人员伤亡。</p>
<p>GEFAHR VON ELEKTRISCHEM SCHLAG, EXPLOSION ODER LICHTBOGEN Für die Plug-In-Basisversion müssen kurze Klemmschirme vom Typ LV429515 oder LV429516 am Leistungsschalter montiert werden. Die Nichtbeachtung dieser Anweisungen führt zu Tod oder schweren Verletzungen.</p>	<p>RISCHIO DI FOLGORAZIONE, ESPLOSIONI O ARCO ELETTRICO Per la versione a base plug-in, è obbligatorio montare gli schermi di protezione morsettiere corti LV429515 o LV429516 sull'interruttore. Il mancato rispetto di queste istruzioni provocherà morte o gravi infortuni.</p>	<p>RISCO DE ELECTROCUSÃO, DE EXPLOSIÃO, OU DE ARCO ELÉCTRICO Para a versão de base de ligação, é obrigatório montar as blindagens de terminais curtos LV429515 ou LV429516 no disjuntor. A não observância destas instruções resultará em morte, ou ferimentos graves.</p>	<p>ОПАСНОСТЬ ПОРАЖЕНИЯ ЭЛЕКТРИЧЕСКИМ ТОКОМ, ВЗРЫВА ИЛИ ВОЗНИКНОВЕНИЯ ДУГИ Для версии со штепсельным основанием обязательно необходимо установить короткие изоляторы клемм LV429515 или LV429516 на автоматический выключатель. Несоблюдение этих инструкций приведет к смерти или серьезной травме.</p>

⚠️ WARNING / AVERTISSEMENT / ADVERTENCIA / 警告 / WARNUNG / AVVERTIMENTO / ATENÇÃO / ПРЕДУПРЕЖДЕНИЕ

<p>HAZARD OF NON-TRIPPING ● Reset VigiPacT before installation. ● For the plug-in base version, only the VigiPacT Add-on Alarm can be mounted under the plug-in base. Do not mount a VigiPacT Add-on under the plug-in base. Failure to follow these instructions can result in death, serious injury, or equipment damage.</p>	<p>RISQUE DE NON-DECLenchement ● Réarmez le VigiPacT avant son installation. ● Pour la version débrochable sur socle, seul le VigiPacT Add-on Alarm peut être monté sous le socle débrochable. Ne montez pas le VigiPacT Add-on sous le socle débrochable. Si ces directives ne sont pas respectées, cela peut entraîner la mort ou des blessures graves ou des dommages matériels.</p>	<p>RIESGO DE AUSENCIA DE DISPARO ● Restablezca VigiPacT antes de la instalación. ● En la versión de zócalo de desconexión, solo se puede montar VigiPacT Add-on Alarm bajo el zócalo de desconexión. No monte VigiPacT Add-on bajo el zócalo de desconexión. El incumplimiento de estas instrucciones puede causar la muerte, lesiones serias o daño al equipo.</p>	<p>不脱扣的风险 ● 安装前，先复位 VigiPacT。 ● 对于插入式底座版本，在插入式底座下方只能安装 VigiPacT Add-on Alarm。不得将 VigiPacT Add-on 安装在插入式底座下方。 不遵循上述说明可能导致人员伤亡或设备损坏。</p>
<p>GEFAHR DES NICHTAUSLÖSENS ● Der VigiPacT muss vor der Installation zurückgesetzt werden. ● Bei der Plug-In-Basis-Version kann nur der VigiPacT Add-on Alarm unter der Plug-In-Basis montiert werden. Ein VigiPacT Add-on darf nicht unter der Plug-In-Basis montiert werden. Die Nichtbeachtung dieser Anweisungen kann Tod, schwere Verletzungen oder Sachschäden zur Folge haben.</p>	<p>PERICOLO DI MANCATO SGANCIO ● Azzerare VigiPacT prima dell'installazione. ● Per la versione a base plug-in, sotto la base plug-in è possibile montare solo VigiPacT Add-on Alarm. Non montare VigiPacT Add-on sotto la base plug-in. Il mancato rispetto di queste istruzioni può provocare morte, gravi infortuni o danni alle apparecchiature.</p>	<p>PERIGO DE NÃO DISPARO ● Reinicie o VigiPacT antes da instalação. ● Para a versão base do plug-in, apenas o VigiPacT Add-on Alarm pode ser montado sob a base do plug-in. Não monte um VigiPacT Add-on sob a base do plug-in. A não observância destas instruções pode provocar a morte, ferimentos graves, ou danos no equipamento.</p>	<p>ОПАСНОСТЬ НЕСРАБАТЫВАНИЯ ● Произведите сброс VigiPacT перед установкой. ● Для версии со штепсельным основанием под штепсельным основанием можно устанавливать только VigiPacT Add-on Alarm. Устанавливать VigiPacT Add-on под штепсельным основанием нельзя. Несоблюдение этих инструкций может привести к смерти, серьезной травме или повреждению оборудования.</p>

<p>en To install, connect and insulate the device, consult the instruction sheet GHD16276AA.</p>	<p>fr Pour installer, raccorder et isoler l'appareil, consultez la notice de montage GHD16276AA.</p>	<p>es Para instalar, conectar y aislar el dispositivo, consulte la hoja de instrucciones GHD16276AA.</p>	<p>zh 如要安装、连接和隔离设备，请参阅说明书 GHD16276AA。</p>
<p>de Informationen zu Installation, Anschluss und Isolierung des Geräts finden Sie in der Kurzanleitung GHD16276AA.</p>	<p>it Per installare, collegare e isolare il dispositivo, consultare la scheda di istruzioni GHD16276AA.</p>	<p>pt Para instalar, ligar e isolar o dispositivo, consulte a ficha de instruções GHD16276AA.</p>	<p>ru Порядок установки, подключения и изоляции устройства см. в буклете с инструкциями GHD16276AA.</p>

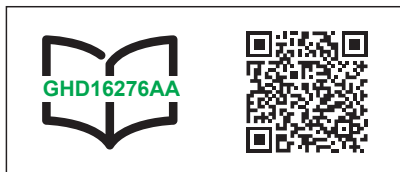
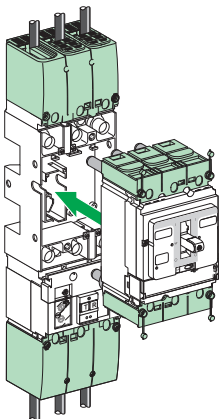

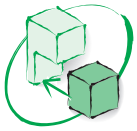

i

VigiPacT Add-on Alarm

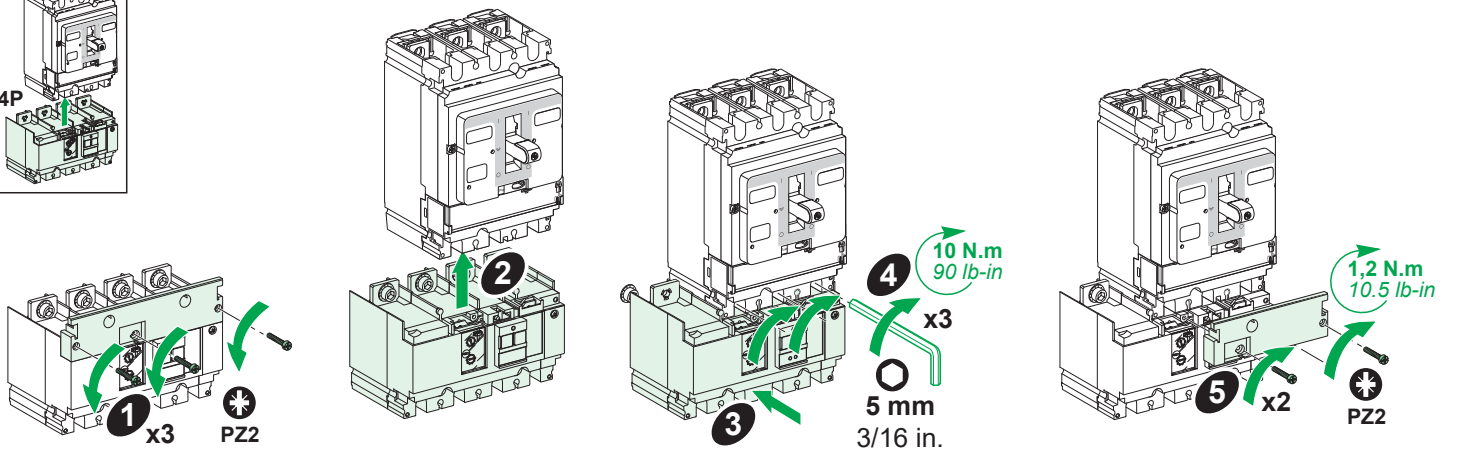
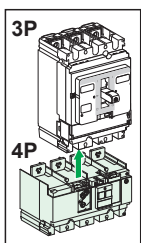
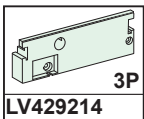
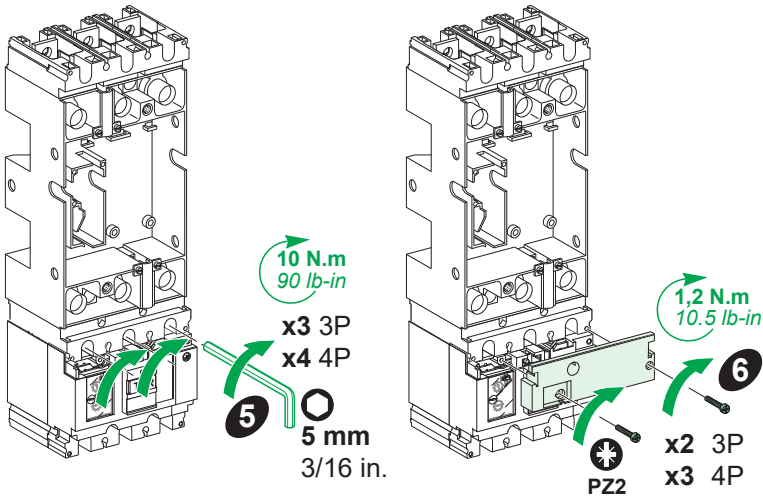
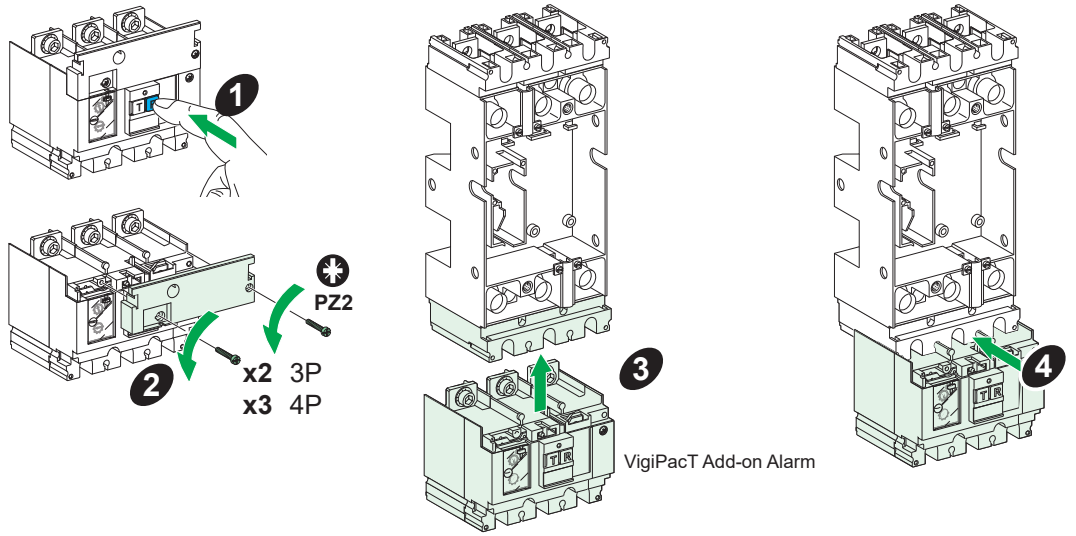
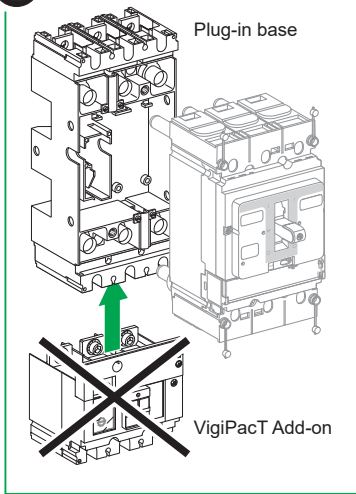

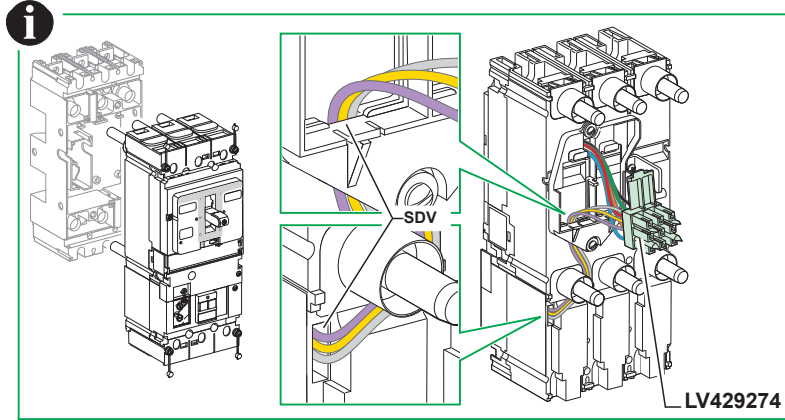
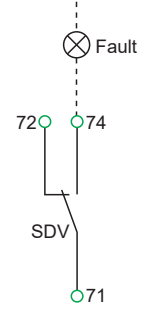
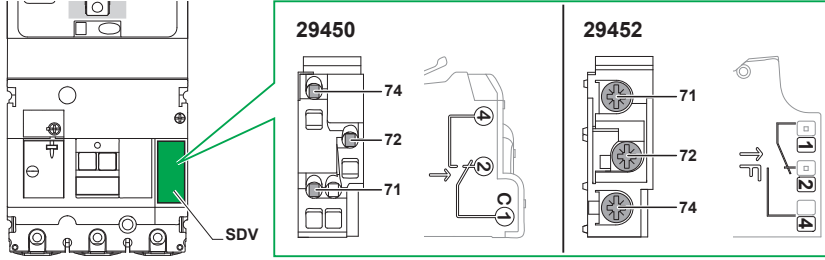
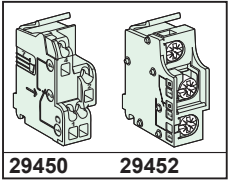

<p>en To install the SDV wired auxiliary signaling contact, consult the instruction sheet NNZ4314501.</p>	<p>fr Pour installer un contact auxiliaire de signalisation câblé SDV, consultez la notice de montage NNZ4314501.</p>	<p>es Para instalar el conector de señalización auxiliar con cable SDV, consulte la hoja de instrucciones NNZ4314501.</p>	<p>zh 如要安装与 SDV 相连的辅助指示触点, 请参阅说明书 NNZ4314501.</p>
<p>de Informationen zur Installation des Hilfssignalkontakts mit SDV-Verdrahtung finden Sie in der Kurzanleitung NNZ4314501.</p>	<p>it Per installare il contatto ausiliario di segnalazione cablato SDV, consultare la scheda di istruzioni NNZ4314501.</p>	<p>pt Para instalar o contacto de sinalização auxiliar com cabos SDV, consulte a ficha de instruções NNZ4314501.</p>	<p>ru Порядок установки проводного вспомогательного сигнального контакта SDV см. в буклете с инструкциями NNZ4314501.</p>

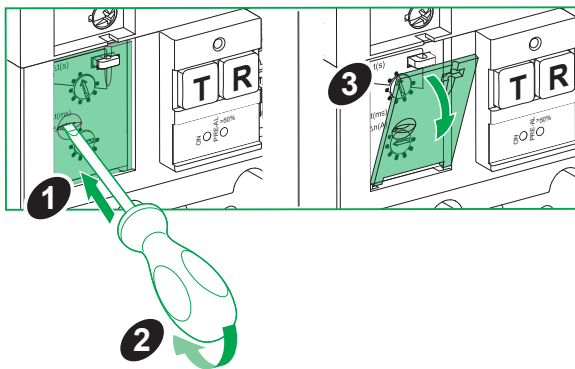

DOCA0187EN
DOCA0187FR
DOCA0187ES
DOCA0187ZH

ComPacT NSX
User Guide

VigiPacT Add-on

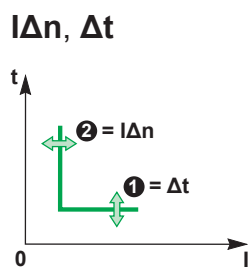
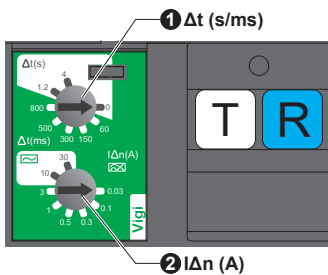

VigiPacT Add-on Alarm

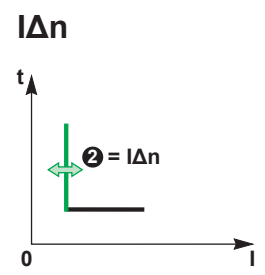
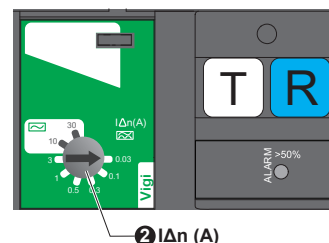



⚠ ⚠ DANGER / DANGER / PELIGRO / 危險 / GEFAHR / PERICOLO / PERIGO / ОПАСНОСТЬ

<p>HAZARD OF ELECTRIC SHOCK, EXPLOSION OR ARC FLASH Take all measures necessary to avoid the risk of electrocution when removing and installing the cover A. The dielectric test is made under voltage. Failure to follow these instructions will result in death or serious injury.</p>	<p>RISQUE D'ÉLECTROCUTION, D'EXPLOSION OU D'ÉCLAIR D'ARC ÉLECTRIQUE Prenez toutes les mesures nécessaires pour éviter les risques d'électrocution lors du démontage et remise en place du couvercle A. Le test diélectrique est effectué sous tension. Si ces directives ne sont pas respectées, cela entraînera la mort ou des blessures graves.</p>	<p>PELIGRO DE DESCARGA ELÉCTRICA, EXPLOSIÓN O ARCO ELÉCTRICO Tome todas las medidas necesarias para evitar el riesgo de electrocución al quitar e instalar la tapa A. La prueba dieléctrica se realiza con tensión. El incumplimiento de estas instrucciones provocará lesiones graves o incluso la muerte.</p>	<p>存在触电、爆炸或者电弧灼伤的危險 移除和安装护盖 A 时，应采取一切必要措施，避免触电风险。介电测试在施加电压的条件下进行。 不遵循上述说明将导致人员伤亡。</p>
<p>GEFAHR VON ELEKTRISCHEM SCHLAG, EXPLOSION ODER LICHTBOGEN Ergreifen Sie alle erforderlichen Sicherheitsvorkehrungen, um die Gefahr eines elektrischen Schlags beim Entfernen und Installieren der Abdeckung A zu vermeiden. Die dielektrische Prüfung wird unter Spannung durchgeführt. Die Nichtbeachtung dieser Anweisungen führt zu Tod oder schweren Verletzungen.</p>	<p>RISCHIO DI FOLGORAZIONE, ESPLOSIONI O ARCO ELETTRICO Prendere tutte le misure necessarie per evitare il rischio di folgorazione quando si rimuove e installa il coperchio A. Il test dielettrico viene eseguito sotto tensione. Il mancato rispetto di queste istruzioni provocherà morte o gravi infortuni.</p>	<p>RISCO DE ELECTROCUSSÃO, DE EXPLOSIÃO, OU DE ARCO ELÉCTRICO Tome todas as medidas necessárias para evitar o risco de eletrocussão ao remover e instalar a tampa A. O teste dielétrico é feito sob tensão. A não observância destas instruções resultará em morte, ou ferimentos graves.</p>	<p>Опасность поражения электрическим током, взрыва или возникновения дуги Примите все необходимые меры, чтобы избежать риска поражения электрическим током при демонтаже и установке крышки A. Испытание на диэлектрическую прочность проводится под напряжением. Несоблюдение этих инструкций приведет к смерти или серьезной травме.</p>

NOTICE / AVIS / AVISO / 注意 / HINWEIS / AVVISO / AVISO / УВЕДОМЛЕНИЕ

<p>HAZARD OF DEVICE DETERIORATION Do not put back the cover A during the dielectric test. Failure to follow these instructions can result in equipment damage.</p>	<p>RISQUE DE DÉTERIORATION DE L'APPAREIL Ne remettez pas le couvercle A pendant le test diélectrique. Si ces directives ne sont pas respectées, cela peut entraîner des dommages matériels.</p>	<p>RIESGO DE DETERIORO DEL DISPOSITIVO No coloque de nuevo la tapa A durante la prueba dieléctrica. El incumplimiento de estas instrucciones puede causar daño al equipo.</p>	<p>设备性能退化风险 介电测试期间，不要放回护盖 A。 不遵循上述说明可能导致设备损坏。</p>
<p>GEFAHR EINER BESCHÄDIGUNG DES GERÄTS Bringen Sie die Abdeckung A während der dielektrischen Prüfung nicht wieder an. Die Nichtbeachtung dieser Anweisungen kann Sachschäden zur Folge haben.</p>	<p>PERICOLO DI DETERIORAMENTO DEL DISPOSITIVO Non reinserire il coperchio A durante il test dielettrico. Il mancato rispetto di queste istruzioni può provocare danni alle apparecchiature.</p>	<p>PERIGO DE DETERIORAÇÃO DO DISPOSITIVO Não recoloque a tampa A durante o teste dielétrico. A não observância destas instruções pode provocar danos no equipamento.</p>	<p>ОПАСНОСТЬ УХУДШЕНИЯ ХАРАКТЕРИСТИК УСТРОЙСТВА Во время испытания на диэлектрическую прочность не устанавливайте на место крышку A. Несоблюдение этих инструкций может привести к повреждению оборудования.</p>

en Before the dielectric test.
fr Avant le test diélectrique.
es Antes de la prueba dieléctrica.
zh 介电测试前。
de Vor der dielektrischen Prüfung
it Prima del test dielettrico.
pt Antes do teste dielétrico.
ru Перед испытанием на диэлектрическую прочность.

en After the dielectric test.
fr Après le test diélectrique.
es Después de la prueba dieléctrica.
zh 介电测试结束后。
de Im Anschluss an eine dielektrische Prüfung.
it Dopo il test dielettrico.
pt Após o teste dielétrico.
ru Действия, выполняемые после испытания на диэлектрическую прочность.

<p>en After performing a dielectric test, carry out an earth-leakage test, see page 13.</p>	<p>fr Après avoir réalisé un test diélectrique, effectuez un test de la protection différentielle, voir page 13.</p>	<p>es Tras realizar una prueba dieléctrica, realice una prueba de diferencial (consulte la página 13).</p>	<p>zh 介电测试结束后，进行接地泄漏测试，参见第 13 页。</p>
<p>de Führen Sie nach einer dielektrischen Prüfung einen Test der Fehlerstromschutzvorrichtung durch (siehe Seite 13).</p>	<p>it Dopo aver eseguito un test dielettrico, eseguire il test differenziale, vedere a pagina 13.</p>	<p>pt Após a realização do teste dielétrico, faça o teste diferencial, consulte a página 13.</p>	<p>ru После испытания на диэлектрическую прочность выполните проверку утечки на землю, см. с. 13.</p>



en Press the test button to simulate an earth-leakage fault, which allows the differential protection function to be tested.
This test is mandatory before commissioning.
Periodic test: In case of absence of local regulation, Schneider Electric recommends that the test is carried out (1) every 3 months or (2) once a month for devices in corrosive, dusty or harsh environment.

fr Appuyez sur le bouton de test pour simuler un défaut de fuite à la terre et tester la fonction de protection différentielle.
Ce test est obligatoire avant la mise en service.
Test périodique : en l'absence de réglementation locale, Schneider Electric recommande d'effectuer ce test (1) tous les 3 mois ou (2) une fois par mois sur les équipements en environnement corrosif, poussiéreux ou exigeant.

es Pulse el botón de prueba para simular un fallo por diferencial, lo cual permite probar la función de protección diferencial.
Es obligatorio realizar esta prueba antes de la puesta en marcha.
Prueba periódica: En caso de ausencia de legislación local, Schneider Electric recomienda realizar la prueba (1) cada 3 meses o (2) una vez al mes para dispositivos en entornos adversos, polvorientos o corrosivos.

zh 按下测试按钮，模拟接地泄漏故障，从而测试差动保护功能。
在试运行前，必须进行这项测试。
周期性测试：如果当地没有相关规定，Schneider Electric 建议：(1) 每 3 个月进行一次测试，或者 (2) 对于在腐蚀性、多尘或恶劣环境中运行的设备，每月进行一次测试。

de Drücken Sie den Testschalter, um einen Erdschluss zu simulieren, damit die Differentialschutzfunktion geprüft werden kann.
Diese Prüfung muss vor der Inbetriebnahme durchgeführt werden.
Periodische Prüfung: Wenn keine örtliche/regionale/landesspezifische Regelung vorhanden ist, empfiehlt Schneider Electric die Durchführung der Prüfung (1) alle 3 Monate bzw. (2) einmal pro Monat für Geräte, die in einer korrosiven, staubigen oder rauen Umgebung eingesetzt werden.

it Premere il pulsante di test per simulare un guasto di dispersione di terra, che consente di provare la funzione di protezione differenziale.
Questo test è obbligatorio prima della messa in servizio.
Test periodico: in caso di assenza di regolamentazione locale, Schneider Electric consiglia di eseguire il test (1) ogni 3 mesi o (2) una volta al mese per dispositivi in ambiente corrosivo, polveroso o rigoroso.

pt Pressione o botão de teste para simular um defeito diferencial, permitindo que a proteção diferencial seja testada.
Esse teste é obrigatório antes do funcionamento.
Teste periódico: em caso de ausência de regulação local, a Schneider Electric recomenda que o teste seja realizado (1) a cada 3 meses ou (2) uma vez ao mês para dispositivos em ambientes corrosivos, empoeirados ou extremos.

ru Нажмите кнопку «Тест» для имитации отказа из-за утечки на землю, чтобы проверить работу дифференциальной защиты.
Данные испытания являются обязательными перед вводом в эксплуатацию.
Периодические испытания: в случае отсутствия местных технических норм компания Schneider Electric рекомендует проводить испытания: 1) раз в три месяца; или 2) раз в месяц для устройств, которые находятся в агрессивной или пыльной среде либо эксплуатируются в тяжелых условиях.

⚠️ DANGER / DANGER / PELIGRO / 危險 / GEFAHR / PERICOLO / PERIGO / ОПАСНОСТЬ			
<p>HAZARD OF ELECTRIC SHOCK, EXPLOSION OR ARC FLASH Take all measures necessary to avoid the risk of electrocution when the external power supply voltage is greater than 30 V~. Failure to follow these instructions will result in death or serious injury.</p>	<p>RISQUE D'ÉLECTROCUTION, D'EXPLOSION OU D'ÉCLAIR D'ARC ÉLECTRIQUE Prenez toutes les mesures nécessaires pour éviter les risques d'électrocutions lorsque la tension de l'alimentation externe est supérieure à 30 V~. Si ces directives ne sont pas respectées, cela entraînera la mort ou des blessures graves.</p>	<p>PELIGRO DE DESCARGA ELÉCTRICA, EXPLOSIÓN O ARCO ELÉCTRICO Tome todas las medidas necesarias para evitar el riesgo de electrocución cuando la tensión de la fuente de alimentación externa sea superior a 30 V~. El incumplimiento de estas instrucciones provocará lesiones graves o incluso la muerte.</p>	<p>存在触电、爆炸或者电弧灼伤的危險 当外部电源电压高于 30 V~。 不遵循上述说明将导致人员伤亡。</p>
<p>GEFAHR VON ELEKTRISCHEM SCHLAG, EXPLOSION ODER LICHTBOGEN Ergreifen Sie alle erforderlichen Sicherheitsvorkehrungen, um die Gefahr eines elektrischen Schlags zu vermeiden, wenn die externe Spannungsversorgung eine Spannung von über 30 V~. Die Nichtbeachtung dieser Anweisungen führt zu Tod oder schweren Verletzungen.</p>	<p>RISCHIO DI FOLGORAZIONE, ESPLOSIONI O ARCO ELETTRICO Prendere tutte le misure necessarie ad evitare il rischio di scossa elettrica quando la tensione di alimentazione esterna è superiore a 30 V~. Il mancato rispetto di queste istruzioni provocherà morte o gravi infortuni.</p>	<p>RISCO DE ELECTROCUSSÃO, DE EXPLOÇÃO, OU DE ARCO ELÉCTRICO Tome todas as medidas necessárias para evitar o risco de electrocussão se a tensão de alimentação externa for superior a 30 V~. A não observância destas instruções resultará em morte, ou ferimentos graves.</p>	<p>Опасность поражения электрическим током, взрыва или возникновения дуги Примите все необходимые меры, чтобы избежать риска поражения электрическим током, когда внешнее напряжение питания более 30 В~ перем. Несоблюдение этих инструкций приведет к смерти или серьезной травме.</p>

VigiPacT Add-on

1
VL-L ≥ 200 V~

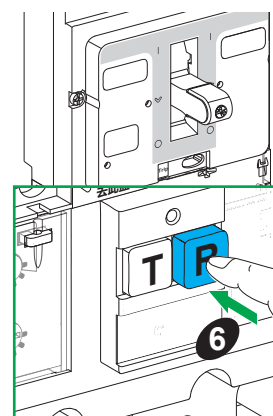
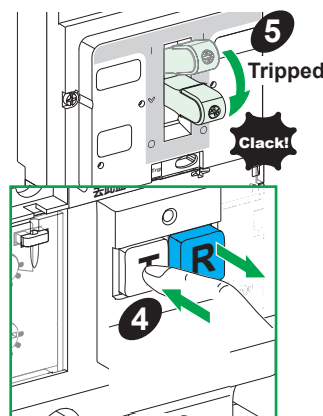
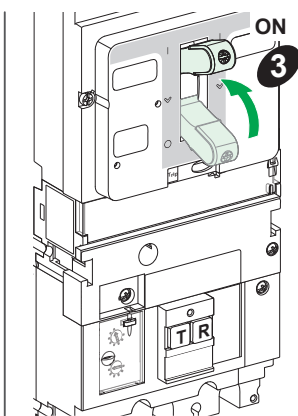
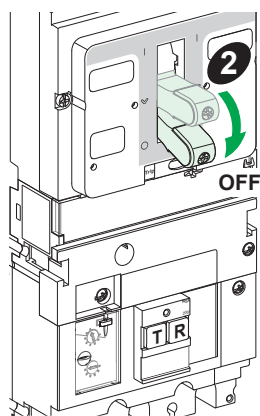
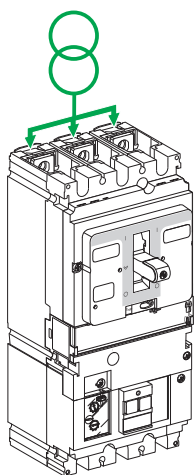

i

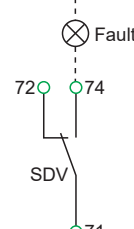
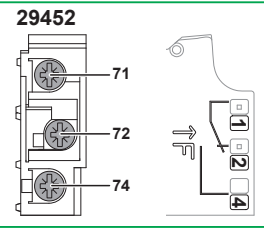
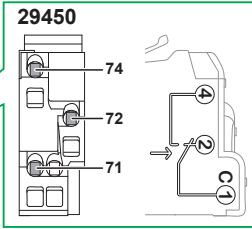
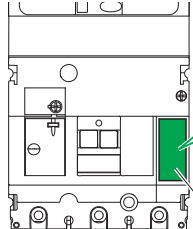
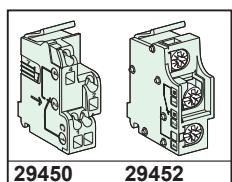



VigiPacT Add-on Alarm

VL-L ≥ 200 V~

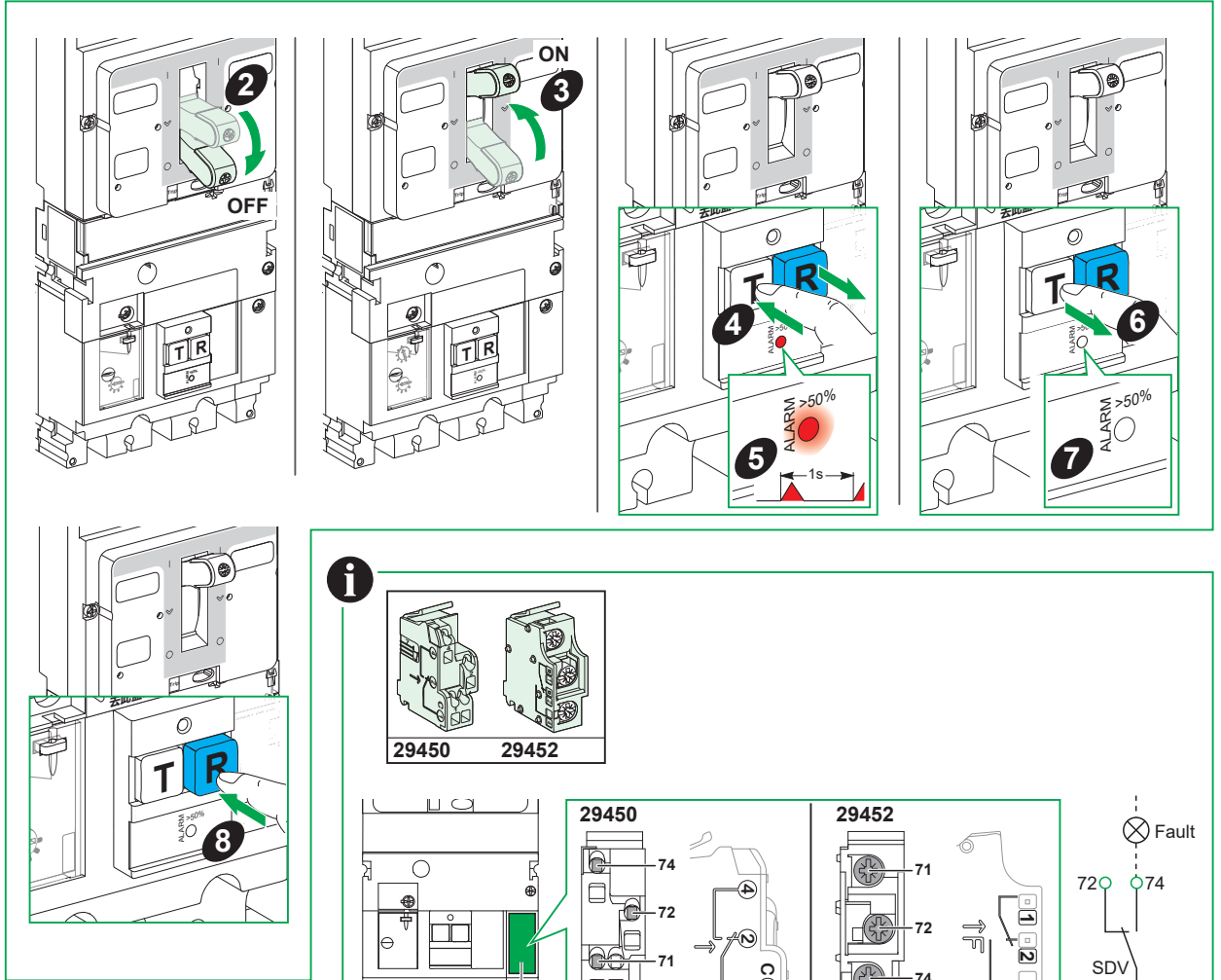
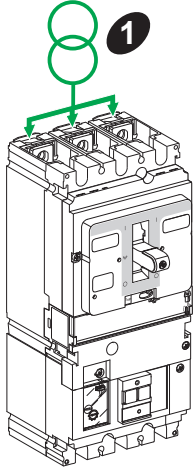

i

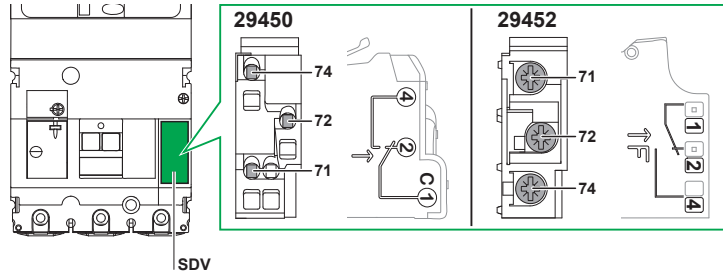
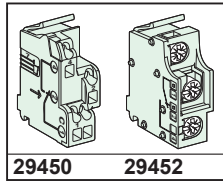

i

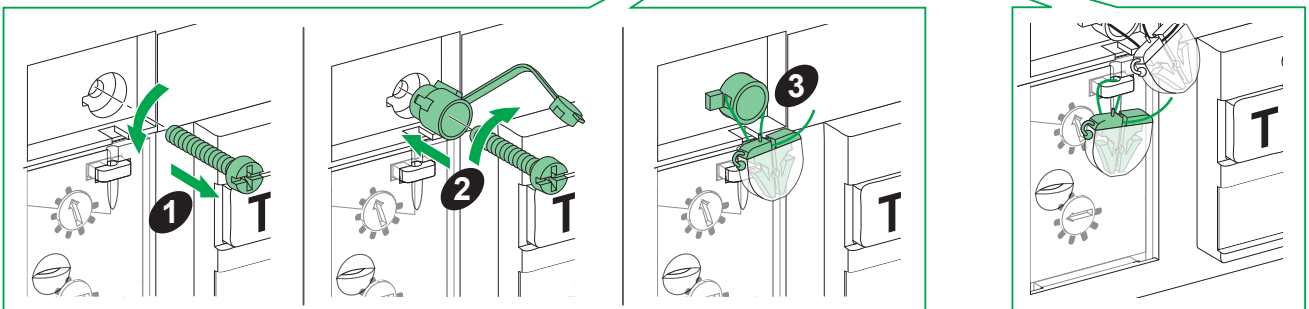
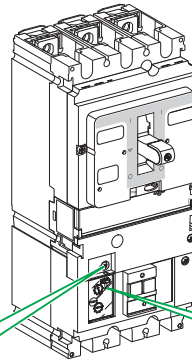
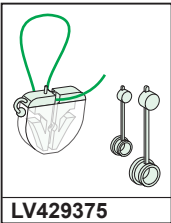

<p>The product's manufacture date is coded PP-YYYY-Www-D, where:</p> <ul style="list-style-type: none"> ● PP: plant code ● YYYY: year of manufacture ● Www: week of manufacture ● D: weekday of manufacture (Monday = 1) <p>Eg: 7Q-2020-W19-3 = product manufactured at plant 7Q on Wednesday 6 May 2020</p>	<p>La date de fabrication du produit est codée PP-YYYY-Www-D, avec:</p> <ul style="list-style-type: none"> ● PP: code usine ● YYYY: année de fabrication ● Www: semaine de fabrication ● D: jour de fabrication dans la semaine (lundi = 1) <p>Ex: 7Q-2020-W19-3= produit fabriqué le mercredi 6 mai 2020 par l'usine 7Q.</p>	<p>La fecha de fabricación del producto está codificada PP-YYYY-Www-D, donde:</p> <ul style="list-style-type: none"> ● PP: código de la planta ● YYYY: año de fabricación ● Www: semana de fabricación ● D: día de la semana de fabricación (lunes = 1) <p>Ej: 7Q-2020-W19-3 = producto fabricado en la planta 7Q el miércoles 6 de mayo de 2020.</p>	<p>产品制造日期采用如下代码 PP-YYYY-Www-D, 其中:</p> <ul style="list-style-type: none"> ● PP: 工厂代码 ● YYYY: 制造年份 ● Www: 第几周制造 ● D: 星期几制造 (星期一 = 1) <p>例如: 7Q-2020-W19-3 = 产品于 2020 年 5 月 6 日星期三在 7Q 工厂制造。</p>
<p>Das Herstellungsdatum des Produkts ist folgendermaßen codiert: PP-YYYY-Www-D. Wobei:</p> <ul style="list-style-type: none"> ● PP: Werkscode ● YYYY: Herstellungsjahr ● Www: Herstellungswoche ● D: Herstellungstag (Montag = 1) <p>Z. B.: 7Q-2020-W19-3 = ein Produkt, das in Werk 7Q, am Mittwoch den 6. Mai, im Jahr 2020 gefertigt wurde.</p>	<p>La data di fabbricazione del prodotto è indicata con il codice PP-YYYY-Www-D, dove:</p> <ul style="list-style-type: none"> ● PP: codice stabilimento ● YYYY: anno di fabbricazione ● Www: settimana di fabbricazione ● D: giorno della settimana in cui il prodotto è stato fabbricato (lunedì = 1) <p>Ad es. 7Q-2020-W19-3 = prodotto fabbricato presso lo stabilimento 7Q mercoledì 6 maggio 2020.</p>	<p>A data de fabrico do produto está sob a forma de código PP-YYYY-Www-D, onde:</p> <ul style="list-style-type: none"> ● PP: código da fábrica ● YYYY: ano de fabrico ● Www: semana de fabrico ● D: dia da semana de fabrico (Segunda-feira = 1) <p>Ex: 7Q-2020-W19-3 = produto fabricado na fábrica 7Q na Quarta-feira 6 de Maio de 2020.</p>	<p>Дата производства продукта закодирована в формате PP-YYYY-Www-D, где:</p> <ul style="list-style-type: none"> ● PP: код завода ● YYYY: год производства ● Www: неделя производства ● D: день недели, когда был произведен продукт (понедельник = 1) <p>Пример. 7Q-2020-W19-3 = продукт произведен на заводе 7Q в среду, 6 мая 2020 года.</p>

Schneider Electric Industries SAS
35, rue Joseph Monier
CS 30323
F - 92506 Rueil Malmaison Cedex
www.se.com



Printed on recycled paper.

Schneider Electric Limited
Stafford Park 5
Telford, TF3 3BL
United Kingdom
www.se.com/uk

**UK
CA**