

1537 - Koala - COB

Code: 431829-00

GENERAL INFORMATION

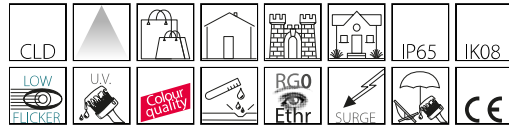

Article	1537 - Koala - COB
Code	431829-00

DIMENSIONS AND WEIGHT

Length (mm)	107 mm
Width (mm)	127 mm
Height (mm)	180 mm
Diameter (Ø) (mm)	114 mm
Weight (Kg)	0.772 kg

ELECTRICAL CHARACTERISTICS AND CONTROLS

Voltage type	AC
Min Voltage (V)	220 V
Max Voltage (V)	240 V
Min Frequency (Hz)	50 Hz
Max Frequency (Hz)	60 Hz
Frequency (Hz)	50 Hz
Wiring name	CLD
Power factor	≥0.9
Insulation class	Class I
Controllability	None



Restyling of the classic garden spotlight with a slender shape. The LED in outdoor lighting is now a guarantee for quality with the advantage of significant energy savings. In the LED version, Koala ensures excellent colour rendering that guarantee perfect, homogeneous light, especially for the lighting of monuments or building façades. Carefully designed for maximum efficiency and durability. Available with multiple accessories and in three colours: silver, graphite, corten.



1537 - Koala - COB

Code: 431829-00

PHOTOMETRIC DATA

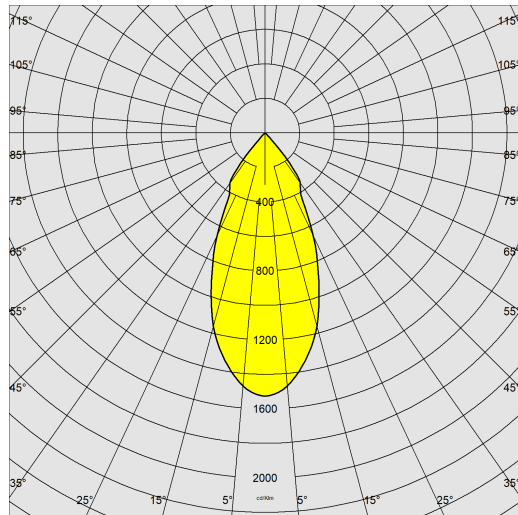

Lighting source	LED COB
CRI	90
Luminous flux (output) (lm)	1195 lm
Power absorption (total) (W)	15 W
CCT	3000 K
Luminous efficacy (lm/W)	80 lm/W
Beam angle	46 °
LED flux maintenance	50000 hr, L 70, B 50

MECHANICAL CHARACTERISTICS

Impact resistance rating (IK)	IK08
IP	65



1537 - Koala - COB

Code: 431829-00

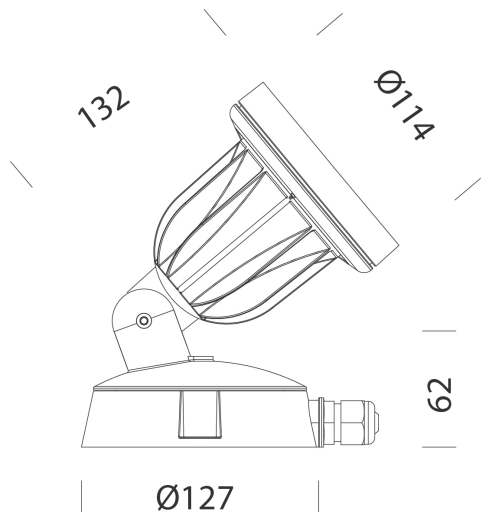

DOWNLOAD

MOUNTS

[AssemblyInstructions KOALA 09-22.pdf](#)

DESIGNS

[BIM 1537 Koala - COB - 20200611.zip](#)

[TechnicalDrawing 1537di.dxf](#)



MATERIALS AND COLOURS

Housing	in die-cast aluminium with cooling fins integrated in the cover.
Optics	in high-performance metallised polycarbonate.
Diffuser	screen-printed, tempered glass.
Coating	graphite with pre-treatment of metal surface, epoxy-based cataphoresis treatment to ensure resistance to corrosion and salt spray fogs, a second final hand of liquid two-component acrylic coating, UV stabilised.
Colour	Graphite
Equipment	cable gland diam. 3/8.

STANDARDS AND COMPLIANCE

Photobiological safety class	RG0 Ethr
Markings and tests	CE
Reference standards	EN60598-1. With degree of protection according to EN60529.
Energy Label	E

WARRANTY

After sales warranty	3 yr
----------------------	------

1537 - Koala - COB

Code: 431829-00



118 Terminal

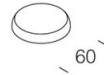

115 Pole cap

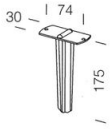

119 Spike



116 Angle support

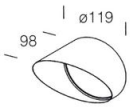

114 Conveyor

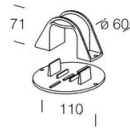

120 Pole support