

1872 - Midifloor

Code: 530791-00

GENERAL INFORMATION

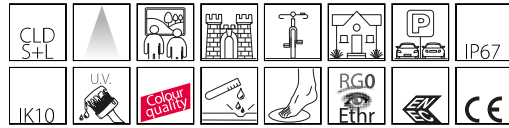

Article	1872 - Midifloor
Code	530791-00

DIMENSIONS AND WEIGHT

Height (mm)	100 mm
Diameter (Ø) (mm)	140 mm
Weight (Kg)	1.132 kg

ELECTRICAL CHARACTERISTICS AND CONTROLS

Voltage type	AC
Min Voltage (V)	220 V
Max Voltage (V)	240 V
Min Frequency (Hz)	50 Hz
Max Frequency (Hz)	60 Hz
Frequency (Hz)	50 Hz
Wiring name	CLD-S+L
Power factor	≥0.95
Insulation class	Class I
Controllability	None



Accent lighting emphasises details and adds a third dimension to objects. Works well in both classic and modern styles producing the same effect.



1872 - Midifloor

Code: 530791-00

PHOTOMETRIC DATA

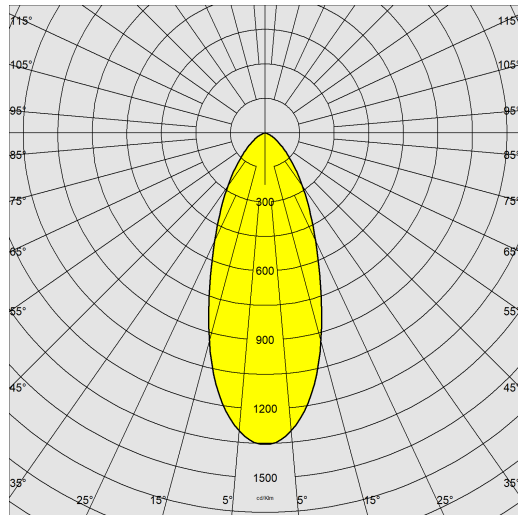

Lighting source	LED COB (GU10)
CRI	80
Luminous flux (output) (lm)	350 lm
Power absorption (total) (W)	6 W
CCT	3000 K
Luminous efficacy (lm/W)	58 lm/W
Beam angle	38 °
LED flux maintenance	50000 hr, L 70, B 50

MECHANICAL CHARACTERISTICS

Impact resistance rating (IK)	IK10
Max load	3000 kg
Walkover	True
Driveover	True
IP	67



1872 - Midifloor

Code: 530791-00

MATERIALS AND COLOURS

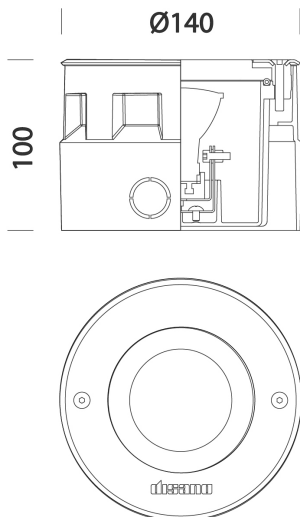

DOWNLOAD

MOUNTS

[AssemblyInstructions midifloor 10-22.pdf](#)

DESIGNS

[BIM 1872 Midifloor-fixed-COB 02-24.zip](#)

[TechnicalDrawing 1871-1872.dxf](#)



Housing	in die-cast aluminium with outer shell in fibreglass nylon, frame in AISI 316L stainless steel.
Optics	in high-performance metallised polycarbonate.
Diffuser	tempered glass, resistant to thermal shock and impact (UNI EN 12150-1:2001).
Colour	Stainless steel
Equipment	<ul style="list-style-type: none"> - standard with flush-mounted boxes. - silicone rubber sealing gasket. - in fibreglass nylon cable gland diam. 1/2 inch gas. - anti-seize bolts
driveway lamp. Keep clear.	

STANDARDS AND COMPLIANCE

Photobiological safety class	RG0 Ethr
Markings and tests	CE, ENEC
Reference standards	EN60598-1. With degree of protection according to EN60529.
Energy Label	E

GEAR

Upon request	Cod. 530791-00 AC220/240V - 50/60Hz Cod. 530792-00 ACC. 179 Cod. 997661-00 MAX 7 @ 350mA Cod. 530793-00 ACC. 179 Cod. 997663-00 MAX 3 @ 350mA
--------------	---

WARRANTY

After sales warranty	3 yr
----------------------	------

1872 - Midifloor

Code: 530791-00

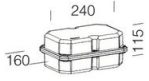

179 IP677 CC wiring