

ESR5-VE3-42 Safety relay



EATON

Powering Business Worldwide

All brand and product names are trademarks or registered trademarks of their respective owners.

Emergency On Call Service

Please call your local representative:

Eaton.eu/aftersales

or

Hotline After Sales Service:

+49 (0) 180 5 223822 (de, en)

AfterSalesEGBonn@eaton.com

Original operating manual

The German-language edition of this document is the original operating manual.

Translation of the original operating manual

All editions of this document other than those in German language are translations of the original operating manual.

2nd Edition 2020, publication date 07/20

See revision protocol in the "About this manual" chapter.

© 2019 by Eaton Industries GmbH, 53105 Bonn, Germany

Editor: René Wiegand

All rights, including those of translation, reserved.

No part of this manual may be reproduced, stored in a retrieval system, or transmitted in any form or by any means, electronic, mechanical, photocopying, micro-filming, recording, or otherwise, without the prior written permission of Eaton Industries GmbH, Bonn, Germany.

Subject to alteration.



Danger! **Dangerous electrical voltage!**

Before commencing the installation

- Disconnect the power supply of the device.
- Ensure that devices cannot be accidentally retriggered.
- Verify isolation from the supply.
- Ground and short-circuit.
- Cover or enclose neighbouring units that are live.
- Follow the engineering instructions (IL) of the device concerned.
- Only suitably qualified personnel in accordance with EN 50110-1/-2 (VDE 0105 Part 100) may work on this device/system.
- Before installation and before touching the device ensure that you are free of electrostatic charge.
- The functional earth (FE) must be connected to the protective earth (PE) or to the potential equalizing. The system installer is responsible for implementing this connection.
- Connecting cables and signal lines should be installed so that inductive or capacitive interference do not impair the automation functions.
- Install automation devices and related operating elements in such a way that they are well protected against unintentional operation.
- Suitable safety hardware and software measures should be implemented for the I/O connection so that a cable or wire breakage on the signal side does not result in undefined states in the automation device.
- Ensure a reliable electrical isolation of the low voltage for the 24 V supply. Only use power supply units complying with IEC 60364-4-41 or HD 384.4.41 S2 (VDE 0100 part 410).
- Deviations of the mains voltage from the nominal value must not exceed the tolerance limits given in the technical data, otherwise this may cause malfunction and dangerous operation.
- Emergency-Stop devices complying with IEC/EN 60204-1 must be effective in all operating modes of the automation devices. Unlatching the emergency switching off devices must not cause restart.
- Built-in devices for enclosures or cabinets must only be run and operated in an installed state, desk-top devices or portable devices only when the housing is closed.
- Measures should be taken to ensure the proper restart of programs interrupted after a voltage dip or failure. This should not cause dangerous operating states even for a short time. If necessary, emergency switching off devices should be implemented.
- Wherever faults in the automation system may cause damage to persons or property, external measures must be implemented to ensure a safe operating state in the event of a fault or malfunction (for example, by means of separate limit switches, mechanical interlocks, etc.).
- During operation, and depending on their degree of protection, variable frequency drives may have live, uninsulated, moving, and/or rotating parts, as well as hot surfaces.
- The impermissible removal of the required cover, improper installation or incorrect operation of the motor or variable frequency drive can cause the failure of the device and serious injury and/or material damage.
- Comply with all applicable national accident prevention regulations (e.g. BGV 4) when working with energized variable frequency drives.
- The electrical installation must be carried out in accordance with the relevant regulations (e.g. with regard to cable cross sections, fuses, PE).
- All transport, installation, commissioning and maintenance work must only be carried out by trained personnel (observe IEC 60364, HD 384 or DIN VDE 0100 and national accident prevention regulations).
- If applicable, systems in which variable frequency drives are installed must be equipped with additional monitoring and protective devices in accordance with the applicable safety regulations, e.g., the German Equipment and Product Safety Act, accident prevention regulations, etc. Making changes to the variable frequency drives by using the operating software is allowed.
- Keep all covers and doors closed during operation.
- When designing the machine, the user must incorporate mechanisms and measures that limit the consequences of a drive controller malfunction or failure (an increase in motor speed or the motor's sudden stop) so as to prevent hazards to people and property, e.g.:
 - Additional stand-alone devices for monitoring parameters that are relevant to safety (speed, travel, end positions, etc.)
 - Electrical and non-electrical safety devices (interlocks or mechanical locks) for mechanisms that protect the entire system
 - Due to the possibility of there being capacitors that are still holding a charge, do not touch live device parts or terminals immediately after disconnecting the variable frequency drives from the supply voltage. Heed the corresponding labels on the variable frequency drives

Content

0	About This Manual.....	3
0.1	List of revisions	3
0.2	Target group.....	3
0.3	Additional documents	3
0.4	Abbreviations and symbols	4
0.4.1	Risk of material damage.....	4
0.4.2	Hazard warnings of personal injury	4
0.4.3	Tips.....	4
0.5	Ordering data	4
1	Safety notes.....	5
2	Description.....	6
3	Operating and indication elements.....	7
3.1	Connection Notes	7
4	Mounting and removing.....	8
5	Wiring.....	9
6	Configuration.....	10
7	Startup	11
8	Protection against manipulation	12
9	Block Diagram	13
10	Derating Curve	14
11	Diagnostics	15

12 Connection Example..... 16

13 Functional test / Proof-Test..... 17

14 Technical data 18

15 Glossary 21

0 About This Manual

This manual applies to the ESR5-VE3-42 safety relay.



Against the background that we do not know your application in detail, the information and examples in this document can only serve as incomplete support for you as a user of safety-related control technology for the implementation of the standards and directives.

The information and examples in this document do not claim to be legally binding or complete.

For detailed information, please refer to the standards and directives that apply to your application.

0.1 List of revisions

The following significant amendments have been introduced since previous issues:

Publication date	Page	Keyword	new	modified	deleted
12/19		First edition	–	–	–
07/20	3,8,18	Update	–	✓	–

0.2 Target group

This manual is particularly aimed at planners, developers and Operators in electrical, control and mechanical engineering who use the device Use ESR5-VE3-42 for safe operation of a machine.

An ESR5-VE3-42 may only be operated by a qualified electrician or a person who is familiar with electrotechnical installation, mounted and connected become



CAUTION

Installation requires a qualified electrician

0.3 Additional documents

For further information, see the following documentation:

- Instruction leaflet IL05013034Z2018_06.pdf

WARNING

Make sure you always use the latest documentation.

It can be downloaded from the product at: Eaton.eu/esr5

0.4 Abbreviations and symbols

The symbols used in this manual have the following meanings:

- ▶ indicates actions to be taken.

0.4.1 Risk of material damage

WARNING

Warns about the possibility of material damage.

0.4.2 Hazard warnings of personal injury



CAUTION

Warns of the possibility of hazardous situations that may possibly cause slight injury.



WARNING

Warns of the possibility of hazardous situations that could result in serious injury or even death.



DANGER

Warns of hazardous situations that result in serious injury or death.

0.4.3 Tips



Indicates useful tips.

0.5 Ordering data

ESR5-VE3-42 safety relay: Catalog No. 118706

1 Safety notes



WARNING

Risk of electric shock

During operation, parts of electrical switching devices carry hazardous voltages.

Before working on the switching device, disconnect the power. Please observe the safety regulations of electrical engineering and industrial safety and liability associations!

Disregarding these safety regulations may result in death, serious personal injury or damage to equipment.

Startup, mounting, modifications, and upgrades should only be carried out by a skilled electrical engineer!



WARNING

Risk of automatic machine restart!

For emergency stop applications, the machine must be prevented from restarting automatically by a higher-level control system.

Protective covers must not be removed when operating electrical switching devices.



WARNING

Danger due to faulty devices!

The devices may be damaged following an error and correct operation can no longer be ensured.

In the event of an error, replace the device immediately.

Repairs to the device, especially if the housing must be opened, may only be carried out by the manufacturer or authorized persons. Otherwise the warranty is invalidated.

CAUTION

Risk of damage to equipment due to incorrect installation

For reliable operation, the safety relay must be installed in housing protected from dust and humidity (IP54).

Carry out wiring according to the application.

Refer to the "Application examples" section for this.

CAUTION

Risk of damage to equipment due to noise emissions

When operating relay modules the operator must meet the requirements for noise emission for electrical and electronic equipment (EN 61000-6-4) on the contact side and, if required, take appropriate measures.

2 Description

The safety relay ESR5-VE3-42 is used as a contact extension for safety relays for Emergency stop and safety door monitoring.

The relay has four enabling current paths, one signalling current path and a feedback path.

Depending on the set time, the contacts drop out with a delay of 0.3 s - 3 s, corresponding to stop category 1 according to DIN EN 60204-1/VDE 0113-1.

In combination with a suitable evaluation unit, which uses the feedback contacts monitored, the device can be used as a contact expansion block with adjustable Contact delay in safety applications up to SIL 3 / SIL CL 3 according to IEC 61508 / EN 62061 and meets the requirements up to category 3 and PL e according to EN ISO 13849-1.

The device can be controlled via a single-channel contact of the base unit.

Features

- Contact extension block
- Suitable up to category 3, PL e (EN ISO 13849-1), SILCL 3 (EN 62061) in conjunction with a suitable evaluation unit
- Single-channel wiring
- Safe isolation
- Housing width 22.5 mm
- Four enable contacts, one alarm contact, and one confirmation contact
- Plug-in screw connection terminal blocks

3 Operating and indication elements

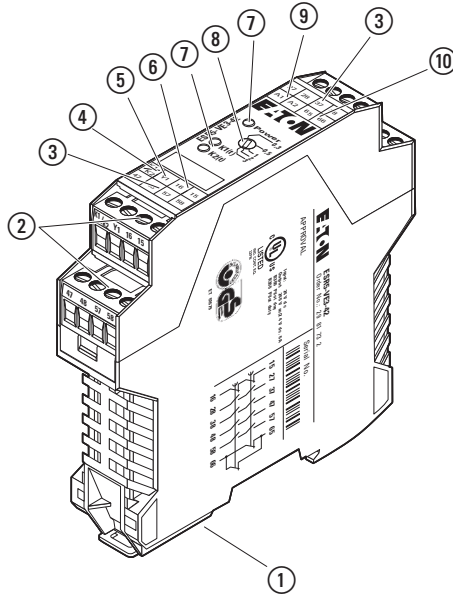

Figure 1: ESR5-VE3-42

- ① Metal lock for mounting on the DIN rail
- ② COMBICON plug-in screw terminal blocks
- ③ 27-28, 37-38, 47-48, 57-58 - Enabling current paths
- ④ K1/K2 - Input
- ⑤ Y1
- ⑥ 15-16 - Confirmation contacts
- ⑦ K1(t), K2(t), Power - LED status indicators
- ⑧ Off delay setting
- ⑨ A1, A2 - Supply voltage connection
- ⑩ 65-66 - Alarm contacts

3.1 Connection Notes



- Before working on the device, disconnect the power.
- Check the set time following installation.
- Devices may only be mounted on/removed when the power is switched off.



In order to comply with UL approval, use copper cables that are designed for operating temperatures $> 75^{\circ}\text{C}$.



For reliable and safe-to-touch contacts, strip the cable ends.

4 Mounting and removing

- ▶ Mount the device on a 35 mm DIN rail according to EN 60715.
- ▶ To remove the device, use a screwdriver to release the snap-on foot.

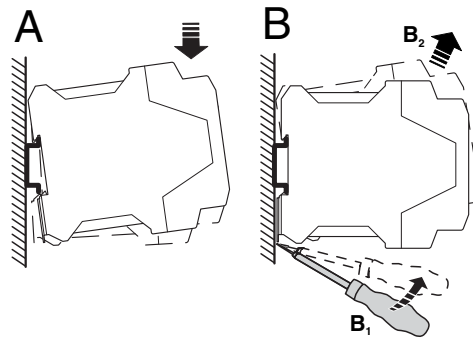

Figure 2: Mounting and removing

5 Wiring

- ▶ Connect the cables to the connection terminal blocks using a screwdriver.

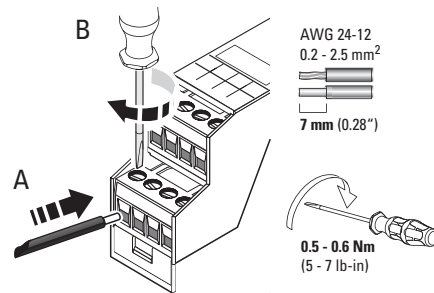

Figure 3: Connecting the cables

6 Configuration

- ▶ Disconnect the safety relay from the supply voltage.
- ▶ Set the delay time at the rotary switch.
- ▶ Restore the power supply.



WARNING

Danger due to incorrect delay time

Check the set delay time following installation!



If the rotary switch is modified during operation, the safety relay switches to configuration mode and the LEDs flash. The safety relay is only ready for operation again once the supply voltage has been switched off and on again and configuration has been carried out.

7 Startup

- ▶ Apply the nominal input voltage U_N (24 V DC) at terminal blocks A1/A2. → The **Power** LED lights up.
- ▶ Apply a 24 V DC voltage at input K1/K2.
 - Both relays are activated.
 - The LEDs light up and the contacts for enabling current paths 27-28, 37-38, 47-48, and 57-58 close.
 - Alarm contacts 15-16 and 65-66 open.
- ▶ Switch off the voltage at input K1/K2.
 - The enable contacts open and the alarm contacts close after the set time has elapsed.



For additional connection examples, see → section 12, "Connection Example", page 16.

8 Protection against manipulation

Once the time has been set, the rotary switch can be protected against manipulation by covering with the label provided.

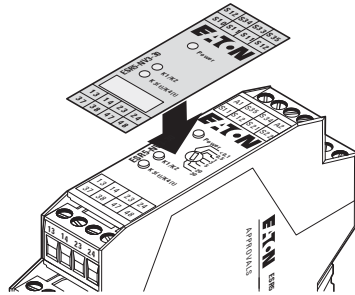

Figure 4: Applying the label

9 Block Diagram

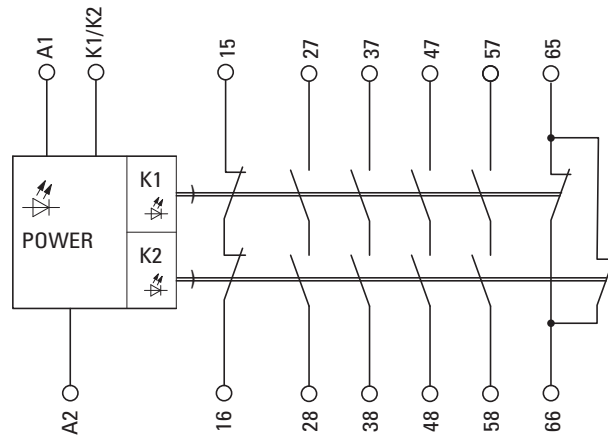

Figure 5: Block diagram

10 Derating Curve

10 Derating Curve

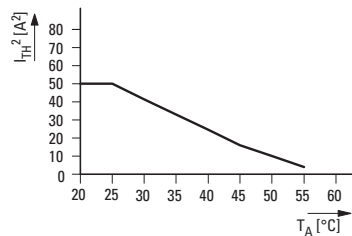

Figure 6: Derating curve

11 Diagnostics

○ – LED off

● – LED on

Table 1: Diagnostic description

	Power	K1(t)	K2(t)	Fault	Remedy
Connection/ voltage error	○	○	○	Supply voltage not present.	Apply supply voltage.
	●	○	○	Supply voltage too low.	Adjust supply voltage.
	○	○	○	The input circuit is connected incorrectly or not connected at all.	Check the connection of the input circuit.
Short circuit	○	○	○	Fault between contact points A1 and A2.	Remove short circuit.
Fault with internal cause	●	○	○	Checkback contacts 15 and 16 faulty.	Replace safety relays.
	●	○	●	Enable contact of K1(t) faulty.	
	●	●	○	Enable contact of K2(t) faulty.	

12 Connection Example

Single-Channel connection with confirmation path 15-16 integrated in the basic device, suitable for up to safety category 3

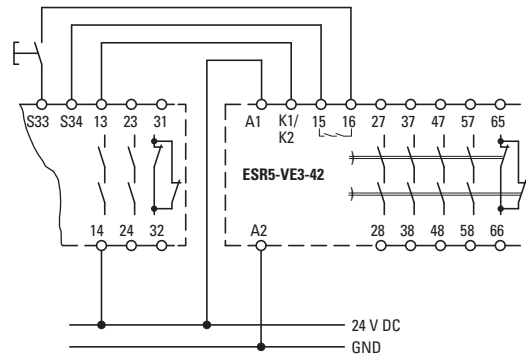

Figure 7: Wiring via connection terminal blocks

13 Functional test / Proof-Test

To prove the function of the device, proceed as follows:

- Request the safety function by actuating the corresponding protective device.
- Check whether the safety function has been performed correctly by reactivating the base unit and thus the contact extension. If the device does not switch on again, the proof test failed.



WARNING





Loss of functional safety due to malfunction!

If the proof test failed, the device will no longer function properly.

- Replace the device.

14 Technical data

Input data	
Nominal input voltage U_N	24 V DC
Input voltage range (factor)	0.85 - 1.1
Typical current consumption at U_N	94 mA
Typical response time (K1, K2)	20 ms
Typical Release time (K1, K2)	0.3 s - 3 s + 50 %
Recovery time	~ 1 s
Status display	LEDs (K1, K2, Power), green
Surge protection	Suppressor diode
Output data	
Contact type	4 enabling current paths 1 signaling current path 1 confirmation path
Contact material	AgSnO ₂
Minimum switching voltage	15 V AC/DC
Maximum switching voltage	250 V AC/DC
Limiting continuous current	6 A (N/O contact) 3 A (N/C contact 65/66)
Maximum inrush current	6 A (N/O contact) 3 A (N/C contact 65/66)
Switching current, minimum	25 mA
Sq. Total current $(I_{TH})^2 = (I_1)^2 + (I_2)^2 + \dots + (I_n)^2$	50 A ² (see derating curve, → Figure 6, page 14)
Interrupting rating (ohmic load) maximum	144 W (24 V DC, $\tau = 0$ ms), N/C contact (65/66): 72 W 288 W (48 V DC, $\tau = 0$ ms), N/C contact (65/66): 144 W 77 W (110 V DC, $\tau = 0$ ms) 88 W (220 V DC, $\tau = 0$ ms) 1500 VA (250 V AC, $\tau = 0$ ms), N/C contact (65/66): 750 VA
Maximum interrupting rating (inductive load)	48 W (24 V DC, $\tau = 40$ ms) 40 W (48 V DC, $\tau = 40$ ms) 35 W (110 V DC, $\tau = 40$ ms) 33 W (220 V DC, $\tau = 40$ ms)
Switching capacity minimum	0.4 W
Mechanical service life	~ 10 ⁷ cycles
Switching capacity (360 cycles/h)	6 A (24 V DC) 5 A (230 V AC)
Switching capacity (3600 cycles/h)	3 A (24 V (DC-13)) 3 A (230 V (AC-15))
Output fuse	10 A gL/gG NEOZED (N/O contact) 6 A gL/gG NEOZED (N/C contact)

General data	
Nominal operating mode	100 % operating factor
Ambient temperature (operation)	-20 °C - 55 °C
Ambient temperature (storage/transport)	-40 °C - 70 °C
Degree of protection	IP20
Min. degree of protection of inst. location	IP54
Mounting position	any
Mounting type	DIN rail mounting
Air and creepage distances between the power circuits	according to DIN EN 50178:1998-04
Rated surge voltage / insulation	Basic insulation 4 kV: between all current paths and housing Safe isolation, reinforced insulation 6 kV
Pollution degree	2
Surge voltage category	III
Dimensions	
W x H x D	22.5 x 99 x 114.5 mm
Connection data	
Conductor cross section, solid	0.2 mm ² - 2.5 mm ²
Conductor cross section, stranded	0.2 mm ² - 2.5 mm ²
Conductor cross section AWG/kcmil	24 - 12
Stripping length	7 mm
Housing material	Polyamide PA, not reinforced
Tests / Approvals	
BG/TÜV	  
UL/CUL	 <p>LISTED IND. CONT. EQ. 32FB</p>

Technical safety data	
Stop category according to IEC 60204	1
Safety parameters for IEC 61508 - High demand	
SIL	3 (in conjunction with suitable evaluating device)
PFH _d	1.35×10^{-9} per hour
Requirement rate	< 12 months
Proof test interval	240 months
Duration of use	240 months
The specifications apply assuming the following calculation basis:	
B _{10d}	300000 (at 5 A DC-13)
Cycles	8760 per year
Safety parameters for IEC 61508 - Low demand	
SIL	3 (in conjunction with suitable evaluating device)
PFD _{avg}	1.49×10^{-4}
Proof test interval	67 months
Duration of use	240 months
Safety characteristic data according to EN ISO 13849	
Category	3 (in conjunction with suitable evaluating device)
Performance Level	e (in conjunction with suitable evaluating device)
Duration of use	240 months
For applications in PL e, the required demand rate for the safety function is once per month. The specifications apply assuming the following calculation basis:	
B _{10d}	300000 (at 5 A DC-13)
Cycles	8760 per year
Safety parameters for EN 62061	
SIL CL	3 (in conjunction with suitable evaluating device)
For SIL CL 3 applications the required demand rate for the safety function is once per month..	

15 Glossary

Abbreviation	Explanation
AOPD	<p>Active optoelectronic protective device Device with a sensor function that is generated by optoelectronic transmit and receive elements, which detects the interruption of optical radiation generated in the device by an opaque object located in the specified protective field (or for a photoelectric barrier on the axis of the light beam).</p> <p>In DIN EN 692 (mechanical presses), DIN EN 693 (hydraulic presses), and EN 12622 (hydraulic trimming presses), the abbreviation AOS is used as a synonym for AOPD.</p>
AOPDDR	<p>Active optoelectronic protective device responsive to diffuse reflection Device with a sensor function that is generated by optoelectronic transmit and receive elements, which detects the diffuse reflection of optical radiation generated in the device by an object located in a protective field specified in two dimensions.</p>
Cat. / Category	Classification of the resistance to faults according to EN ISO 13849-1.
CCF	Common cause failure
DC	Diagnostic coverage
ESPE	Electro-sensitive protective equipment
Mission Time T_M	Duration of use
MTTF / $MTTF_d$	Mean time to failure / mean time to dangerous failure
PF _d	Probability of failure on demand (low demand)
PFH _d	Average frequency of a dangerous failure per hour
PL	<p>Performance level Classification of the ability of safety functions to meet a safety demand</p>
SIL	Safety integrity level
SILCL	SIL claim limit
SRCF	Safety-related control function
SRECS	<p>Safety-related electrical control system (Safety-related electrical, electronic, and programmable electronic control system)</p>
SRP	Safety-related part
SRP/CS	Safety-related parts of control system

Eaton's electrical business is a global leader with expertise in power distribution and circuit protection; backup power protection; control and automation; lighting and security; structural solutions and wiring devices; solutions for harsh and hazardous environments; and engineering services. Eaton develops innovations that not only provide energy for the important things across industries worldwide, but also help customers tackle the most critical electrical power management challenges out there. The Eaton Corporation is a diversified power management company with 2017 sales of 20.4 billion dollars. We provide energy-efficient solutions that help our customers effectively manage electrical, hydraulic, and mechanical power more efficiently, safely, and sustainably. Eaton is dedicated to improving people's quality of life and the environment through the use of power management technologies and services. Eaton has approximately 96,000 employees and sells products to customers in more than 175 countries. For more information, please visit Eaton.eu.

**Eaton addresses worldwide
Eaton.com**

**E-Mail: info-bonn@eaton.com
Internet: Eaton.eu/esr5**

Eaton Industries GmbH
Hein-Moeller-Str. 7-11
D-53115 Bonn

© 2019 by Eaton Corporation
All rights reserved
MN049003 EN ETN/ICPD 07/20



Powering Business Worldwide