

Cassette cell switch – NF

Instructions apply to:

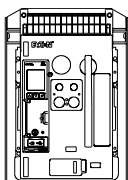

UL489 : PD-NF, Series NRX
IEC : PD-NF, IZMX16

WARNING

- (1) ONLY QUALIFIED ELECTRICAL PERSONNEL SHOULD BE PERMITTED TO WORK ON THE EQUIPMENT.
 - (2) ALWAYS DE-ENERGIZE PRIMARY AND SECONDARY CIRCUITS IF A CIRCUIT BREAKER CANNOT BE REMOVED TO A SAFE WORK LOCATION.
 - (3) DRAWOUT CIRCUIT BREAKERS SHOULD BE LEVERED (RACKED) OUT TO THE DISCONNECT POSITION.
 - (4) ALL CIRCUIT BREAKERS SHOULD BE SWITCHED TO THE OFF POSITION AND MECHANISM SPRINGS DISCHARGED.
- FAILURE TO FOLLOW THESE STEPS FOR ALL PROCEDURES DESCRIBED IN THIS INSTRUCTION LEAFLET COULD RESULT IN DEATH, BODILY INJURY, OR PROPERTY DAMAGE.
-

WARNING

THE INSTRUCTIONS CONTAINED IN THIS IL AND ON PRODUCT LABELS HAVE TO BE FOLLOWED. OBSERVE THE FIVE SAFETY RULES:

- DISCONNECTING
- ENSURE THAT DEVICES CANNOT BE ACCIDENTALLY RESTARTED
- VERIFY ISOLATION FROM THE SUPPLY
- EARTHING AND SHORT-CIRCUITING
- COVERING OR PROVIDING BARRIERS TO ADJACENT LIVE PARTS

DISCONNECT THE EQUIPMENT FROM THE SUPPLY. USE ONLY AUTHORIZED SPARE PARTS IN THE REPAIR OF THE EQUIPMENT. THE SPECIFIED MAINTENANCE INTERVALS AS WELL AS THE INSTRUCTIONS FOR REPAIR AND EXCHANGE MUST BE STRICTLY ADHERED TO PREVENT INJURY TO PERSONNEL AND DAMAGE TO THE SWITCHBOARD.

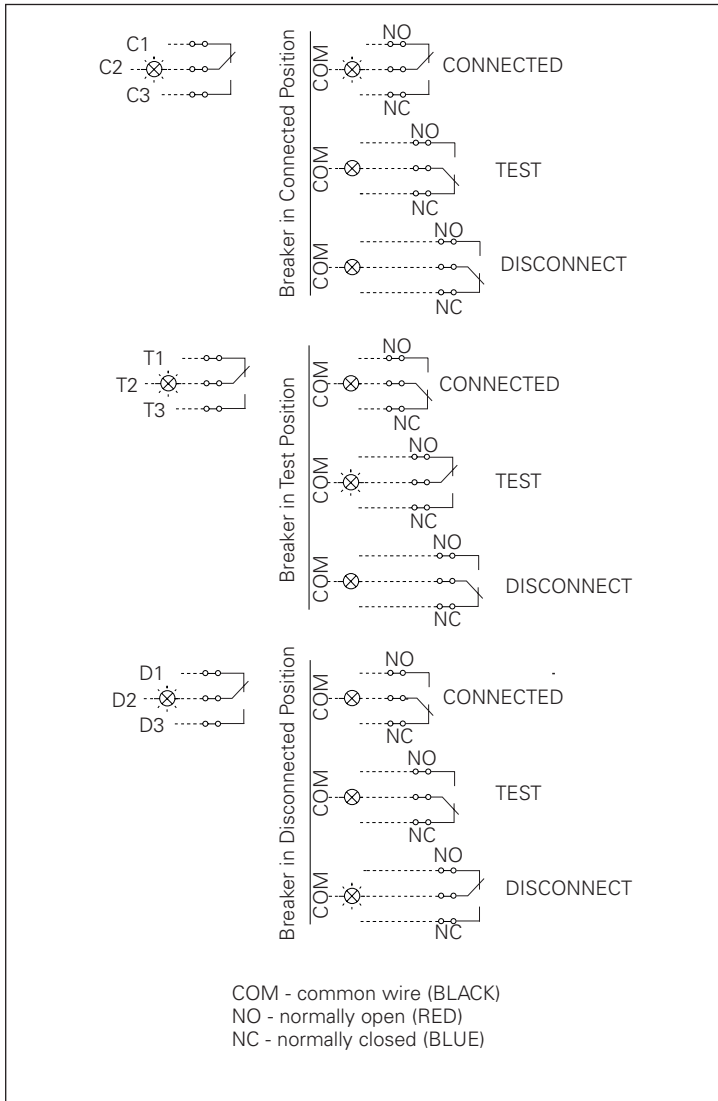

Figure 1. Cell Switch Diagrams.

Section 1: General Information

The cassette cell switch is a compartment position switch for drawout circuit breakers. It is comprised of a cassette mounted switch assembly and a breaker mounted actuator. The switch assembly consists of three SPDT switches, which are operated by a common actuator. Figures 1 and 1a illustrate the switch contact positions when the breaker is in a specific position within the cassette. As the breaker is levered in or out from one position to another, the appropriate switch changes state as a result of contact with the breaker mounted actuator.

Kit Parts Identification

Refer to Figure 2 for visual identification of the parts listed below:

- (A) Cell Switch Assembly (with mounted labels) (1);
- (B) Cell Switch Actuator (1); and
- (C) 10 mm self-threading TORX mounting screw (not shown).

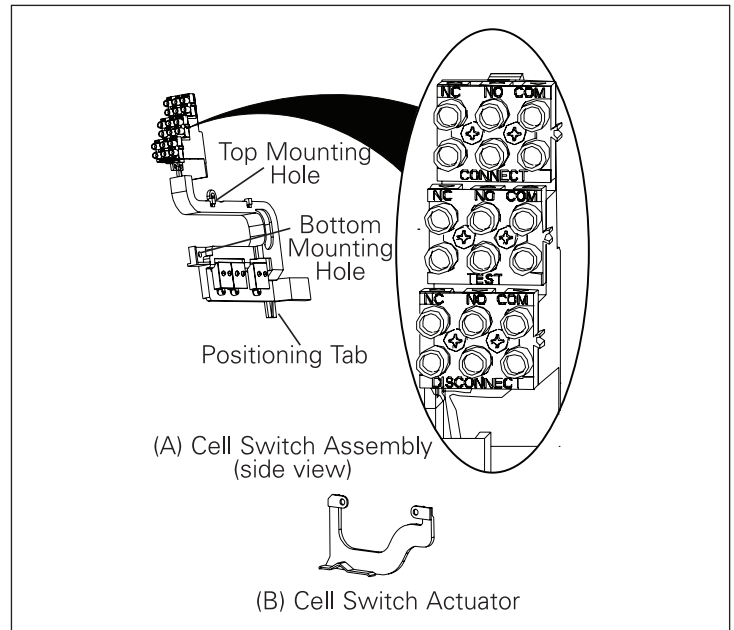

Figure 2. Contents of Kit.

Signaling switch for:	Contacts	Circuit-breaker position		
		Disconnect Position	Test Position	Connected Position
Disconnect Position	COM / NC	█	█	█
	COM / NO	█	█	█
Test Position	COM / NC	█	█	█
	COM / NO	█	█	█
Connected Position	COM / NC	█	█	█
	COM / NO	█	█	█

COM - Common Wire (BLACK)		Contact Open
NO - Normally Open (RED)		Contact Closed
NC - Normally Closed (BLUE)		Contact Closed

Figure 1a. Circuit Breaker Position and Contacts.

Required Tools

- TORX Type Screwdriver (#15)
- TORX Type Screwdriver (#25)
- Small Flat Blade Screwdriver

Section 2: Installation of Cassette Cell Switch

Proceed with the following nine steps:

WARNING

ELECTRICAL SHOCK HAZARD: ALWAYS DE-ENERGIZE PRIMARY AND SECONDARY CIRCUITS PRIOR TO REMOVING THE CIRCUIT BREAKER FROM ITS CASSETTE.

Step 1: Remove the circuit breaker from its cassette prior to starting the installation process.

Step 2: The cell switch assembly (A) is mounted on the inside of the cassette’s left side sheet. Two screws are used to mount the assembly: one 8 mm screw already in the cassette and a 10 mm screw (C) supplied with the cell switch kit. Remove the already mounted 8 mm screw first, using a TORX screwdriver (#25), and use it in the lower mounting hole to thread the lower hole. Once the lower hole is threaded, remove the 8 mm screw and save it for mounting purposes during a later step.

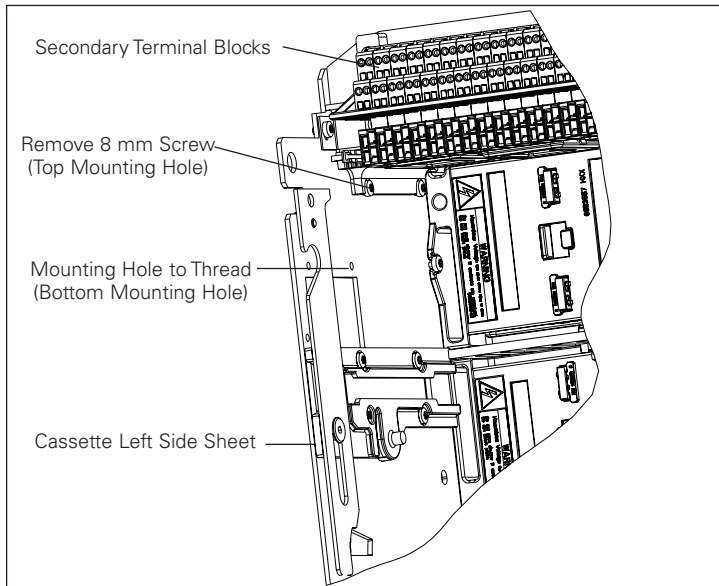

Figure 3. Step 2.

Step 3: Refer to Figure 4 for reference purposes. Mount the cell switch terminal block on the DIN rail to the left of the terminal blocks. This is accomplished by connecting the bottom part of the connection block to the lower part of the DIN rail. The top part of the terminal block can then be snapped onto the upper part of the DIN rail.

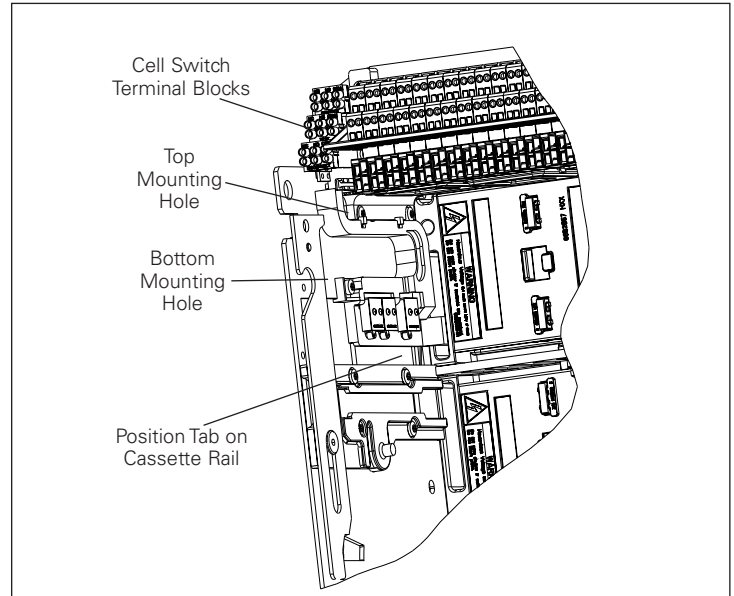

Figure 4. Step 3.

Step 4: Once the cell switch terminal block is mounted as described in the previous step, position the cell switch assembly (A) on the inside of the cassette’s left side sheet so the two mounting holes, indicated in Figure 3, match up with the switch assembly mounting holes indicated in Figure 4. In addition, the position tab on the switch assembly shown in Figure 4 should be positioned on top of the left-side cassette rail.

Step 5: Insert the 10 mm TORX head type mounting screw (C) supplied with the kit into the top mounting hole. Next insert the 8 mm TORX head type mounting screw removed in Step 2 into the bottom mounting hole. Torque both screws to 48-60 lbs-in. (5.4-6.7 N-m). Mounting of the cell switch assembly is now complete.

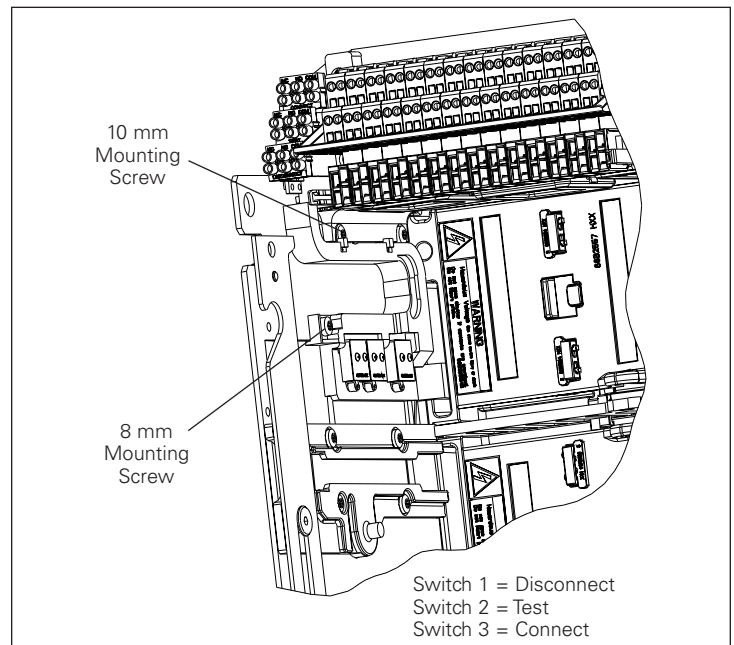

Figure 5. Step 5.

Step 6: The cell switch actuator (B) is now mounted using the TORX head screws that are holding the lifting handle in place on the upper left side of the circuit breaker. Remove the two screws from the handle using a TORX #15 screwdriver.

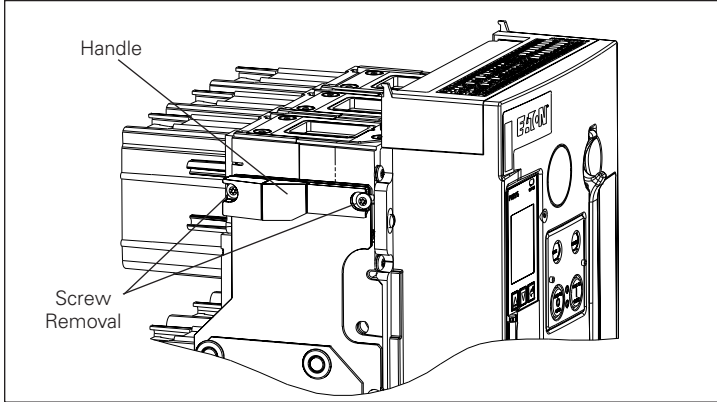

Figure 6. Step 6.

Step 7: Position the cell switch actuator as shown relative the breaker handle and mount both in place using the TORX screws that were removed in Step 6. Torque both mounting screws to 30-35 lbs-in (3.4-4.0 N·m). Mounting of the cell switch actuator is now complete.

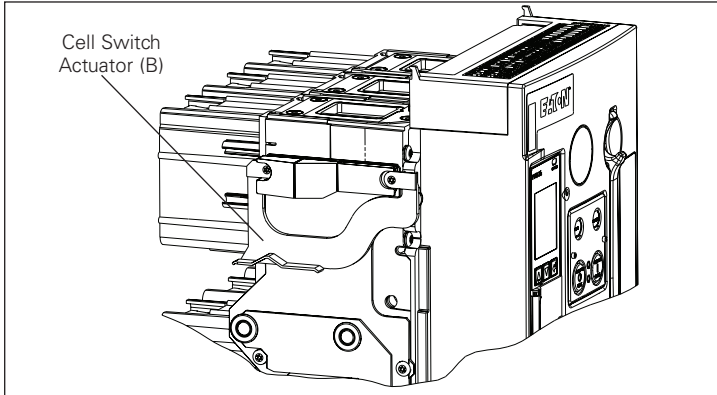

Figure 7. Step 7.

Step 8: Customer cell switch leads should be stripped to a length of 0.197 in. (5 mm). The leads are inserted into wiring access holes on top of the cell switch terminal blocks. While holding the leads securely in place, torque the appropriate screws to 4.4 lbs-in (0.5 N·m) to secure the leads. This completes the installation.

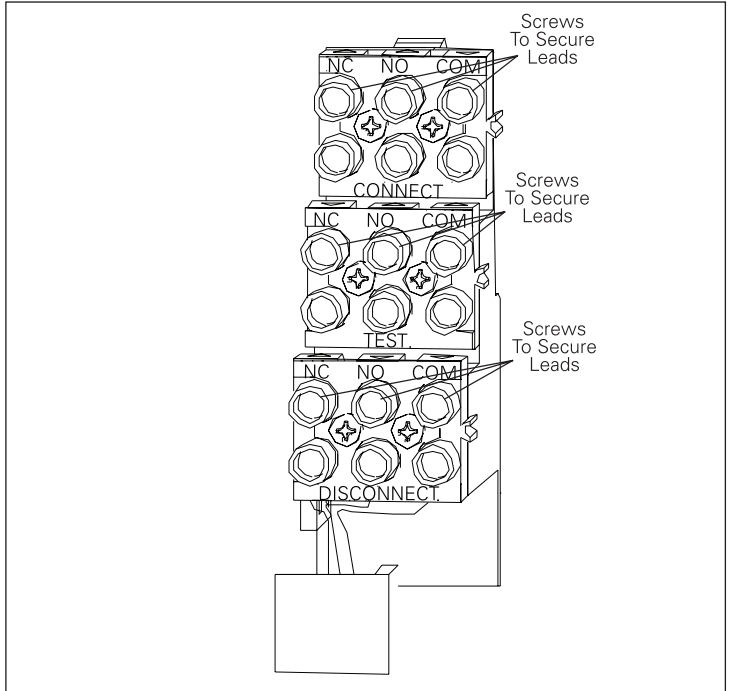

Figure 8. Step 8.

Step 9: The circuit breaker can now be put back into the cassette. Lever the breaker into and out of its three positions to ensure that the cell switch assembly is operating smoothly.

Note: Keep in mind that the indicator on the front of the circuit breaker must indicate that the breaker is in the DISCONNECT position to permit insertion of the breaker into its cassette.

Section 3: Removal of Cassette Cell Switch

Remove the circuit breaker from its cassette and repeat Steps 2 through 8 in reverse order.

IMPORTANT

Recommended maximum electrical ratings @ 250 Vac:

- ENEC 10 (3), 10 A resistive load, 3 A motor load;
- UL/CSA, 0.25 HP 125/250 Vac, 10.1 A 125/250 Vac.

Notes:

Disclaimer of Warranties and Limitation of Liability

The information, recommendations, descriptions, and safety notations in this document are based on Eaton's experience and judgment. This instructional literature is published solely for information purposes and should not be considered all-inclusive. If further information is required, you should consult an authorized Eaton sales representative.

The sale of the product shown in this literature is subject to the terms and conditions outlined in appropriate Eaton selling policies or other contractual agreement between the parties. This literature is not intended to and does not enlarge or add to any such contract. The sole source governing the rights and remedies of any purchaser of this equipment is the contract between the purchaser and Eaton.

NO WARRANTIES, EXPRESSED OR IMPLIED, INCLUDING WARRANTIES OF FITNESS FOR A PARTICULAR PURPOSE OR MERCHANTABILITY, OR WARRANTIES ARISING FROM COURSE OF DEALING OR USAGE OF TRADE, ARE MADE REGARDING THE INFORMATION, RECOMMENDATIONS, AND DESCRIPTIONS CONTAINED HEREIN.

In no event will Eaton be responsible to the purchaser or user in contract, in tort (including negligence), strict liability or otherwise for any special, indirect, incidental or consequential damage or loss whatsoever, including but not limited to damage or loss of use of equipment, plant or power system, cost of capital, loss of power, additional expenses in the use of existing power facilities, or claims against the purchaser or user by its customers resulting from the use of the information, recommendations and description contained herein.

The information contained in this manual is subject to change without notice.

Eaton
Electrical Sector
1000 Eaton Boulevard
Cleveland OH 44122
United States
877-ETN-CARE (877-386-2273)
Eaton.com

© 2019 Eaton
All Rights Reserved
Printed in USA
Publication No. IL0131097EN/LNT07
Part Number: IL0131097ENH02
January 2019