

Installation and removal instructions for Series NRX RF fixed breaker two-way cable interlock kit

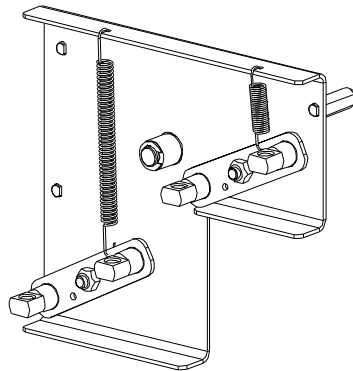

Contents

Description	Page
General information	2
Installation	4
Functional test of interlock assembly	9

Instructions apply to:
Series NRX®, Type RF frame, IEC, IZMX40

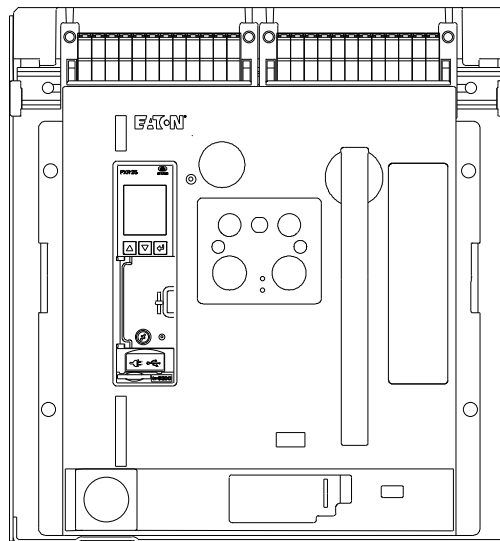

⚠ WARNING

(1) ONLY QUALIFIED ELECTRICAL PERSONNEL SHOULD BE PERMITTED TO WORK ON THE EQUIPMENT.

(2) ALWAYS DE-ENERGIZE PRIMARY AND SECONDARY CIRCUITS IF A CIRCUIT BREAKER CANNOT BE REMOVED TO A SAFE WORK LOCATION.

(3) DRAWOUT CIRCUIT BREAKERS SHOULD BE LEVERED (RACKED) OUT TO THE DISCONNECT POSITION.

(4) ALL CIRCUIT BREAKERS SHOULD BE SWITCHED TO THE OFF POSITION AND MECHANISM SPRINGS DISCHARGED.

FAILURE TO FOLLOW THESE WARNINGS FOR ALL PROCEDURES DESCRIBED IN THIS INSTRUCTION LEAFLET COULD RESULT IN DEATH, BODILY INJURY, OR PROPERTY DAMAGE.

⚠ WARNING

THE INSTRUCTIONS CONTAINED IN THIS IL AND ON PRODUCT LABELS HAVE TO BE FOLLOWED. OBSERVE THE FIVE SAFETY RULES:

- DISCONNECTING
- ENSURE THAT DEVICES CANNOT BE ACCIDENTALLY RESTARTED
- VERIFY ISOLATION FROM THE SUPPLY
- EARTHING AND SHORT-CIRCUITING
- COVERING OR PROVIDING BARRIERS TO ADJACENT LIVE PARTS

DISCONNECT THE EQUIPMENT FROM THE SUPPLY. USE ONLY AUTHORIZED SPARE PARTS IN THE REPAIR OF THE EQUIPMENT. THE SPECIFIED MAINTENANCE INTERVALS AS WELL AS THE INSTRUCTIONS FOR REPAIR AND EXCHANGE MUST BE STRICTLY ADHERED TO PREVENT INJURY TO PERSONNEL AND DAMAGE TO THE SWITCHBOARD.

General information

This information leaflet (IL) provides detailed installation instructions for installing and interconnecting one fixed Type RF frame breaker to another type of low voltage circuit breaker (LVCB) in any position (see A, B in **Table 1**) for a two-way interlock configuration as shown in **Figure 1**. When purchasing kits for a two-way interlock configuration setup, additional interlock kits (the types of interlock kits and the other breakers on which they can be installed that are compatible with this kit are listed in **Table 2**) are required for the other breaker as well as the interconnecting cable kits (one required).

For two-way interlock configurations, the mechanical interlock holds one of the breakers tripped or open (prevents closure) when the other is closed. A lever assembly is mounted on each breaker and interfaces with the pole shaft and trip bar. The lever assemblies are interconnected with cables provided in interconnecting cable kits (listed in **Table 3**) that are compatible with this interlock kit. The cable kits, purchased separately, each contain two cables and can be used for any orientation of the breakers according to the installation recommendations in **Step 9**.

Refer to **Figure 2** and **Figure 3** for identification of interlock kit and interconnecting cable kit contents, respectively.

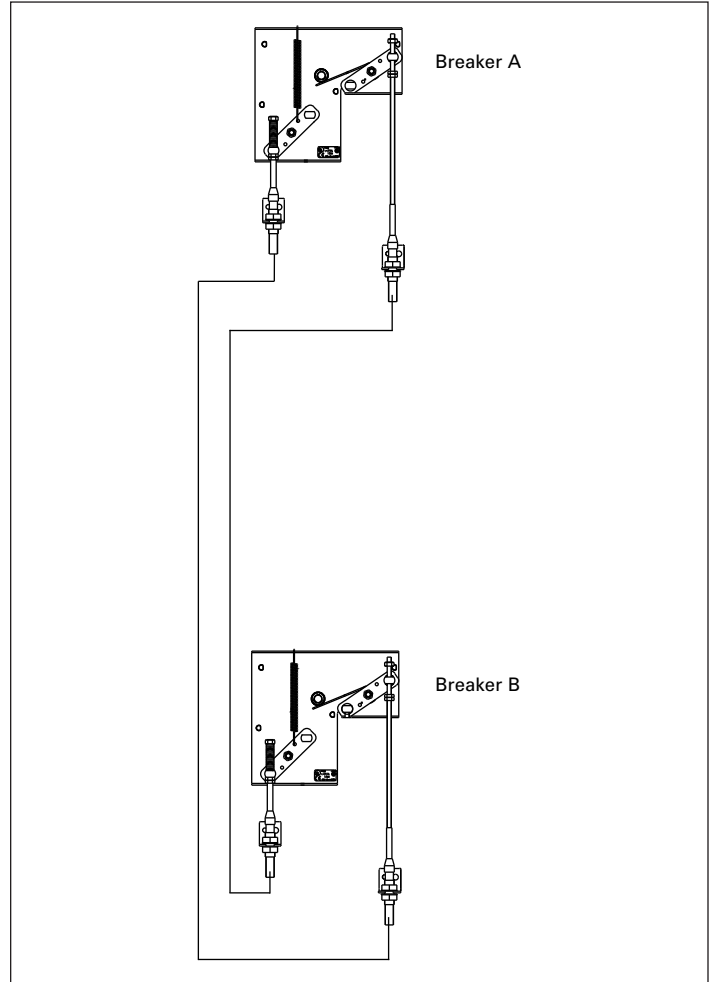

Figure 1. Cable routing for two-way interlock configurations

Table 1. Two-way interlock logic

Breaker A	Breaker B
Allowed states or conditions	
0	0
1	0
0	1

0 = open
1 = closed

Table 2. Interlock assembly kits for interconnected breakers

Interconnected breaker	Interlock assembly kit for fixed breaker	Interlock assembly kit for drawout breaker
NRX Type NF frame	IZMX-MIL2C-F16-2	IZMX-MIL2C-W16-2
NRX Type RF frame	IZMX-MIL2C-F40-2	IZMX-MIL2C-W40-2
Magnum DS®, SB or IZM	MCI2W3W3133FX	MCI2W3W3133DO

Table 3. Interconnecting cable kits (two cables per kit) ①

Cable kit length	Catalogue number
1,5 m (5 ft)	IZMX-MIL-CAB1520-2
1,8 m (6 ft)	IZMX-MIL-CAB1830-2
2,4 m (8 ft)	IZMX-MIL-CAB2440-2
3,0 m (10 ft)	IZMX-MIL-CAB3050-2

① Cable kits are purchased separately as needed.

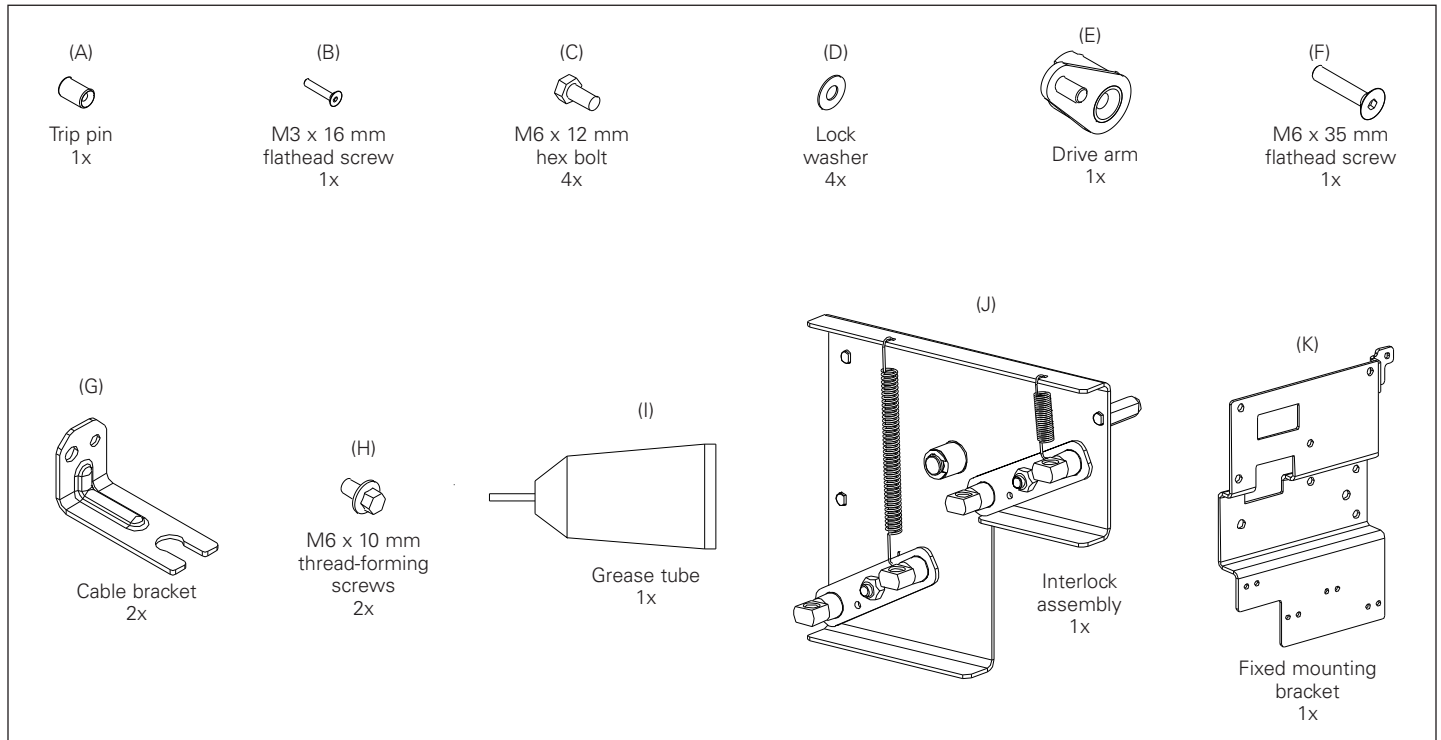

Figure 2. Interlock kit part identification, includes parts to install on a single fixed Type RF frame breaker and cassette (does not include cables)

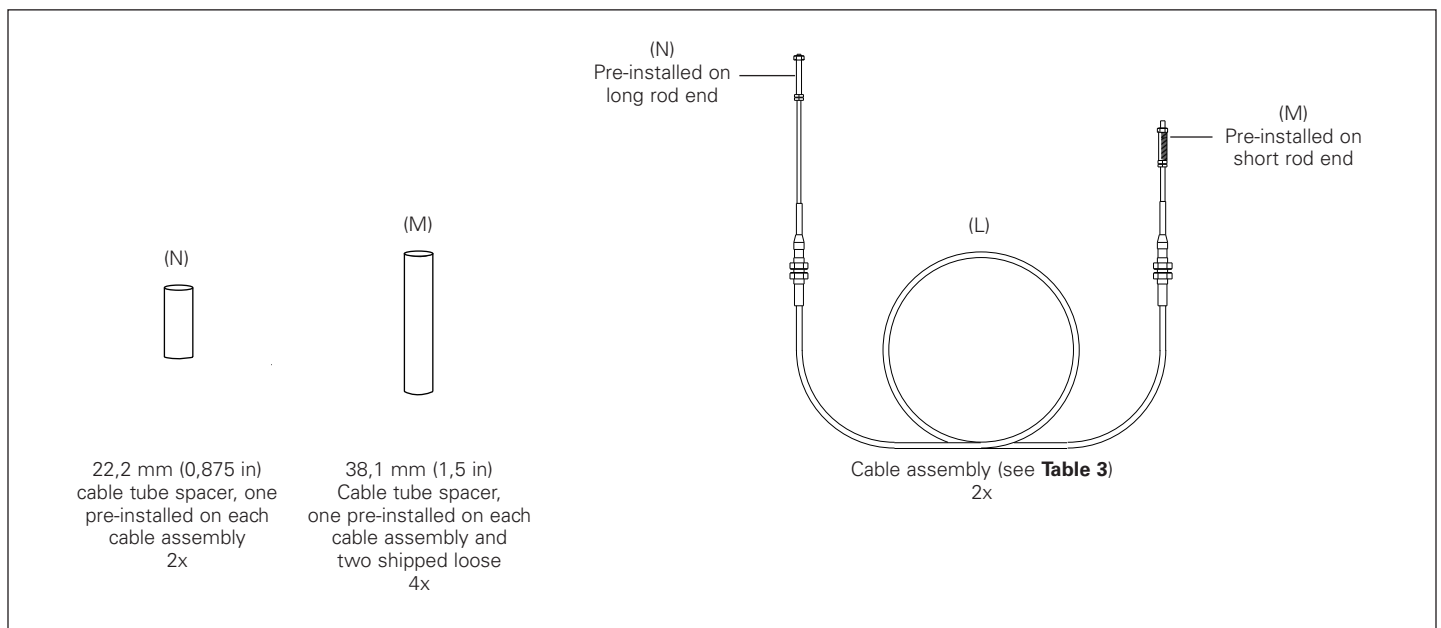

Figure 3. Interconnecting cable kit part identification (includes cables)

Installation

Required tools

- 10 mm hex socket
- 11/16-inch open-end wrench
- 3/8-inch open-end wrench
- 3/8-inch hex socket
- 2 mm Allen wrench
- Drive extension
- Adjustable wrench
- Ratchet
- T15 Torx driver
- Measuring instrument, in mm

Before proceeding with the following steps, ensure that all breakers are in the OPEN and DISCHARGED position.

Step 1

Remove the four screws (six for 4-pole breaker) holding the cover in place. Pull down on the charging handle and remove the front cover as shown in **Figure 4**. Remove drive arm window as shown in **Figure 5**. Either use a utility knife to cut the window from the cover or use a punch and a small hammer to carefully punch out the window. Once the window is removed, use a small file to remove any burrs that remain. Make certain that all pieces and/or particles are cleaned up and removed before proceeding.

Step 2

Remove and retain the upper right M5 x 12 mm screw from the fixed breaker mounting foot (ref. IL01301076E) as shown in **Figure 4**.

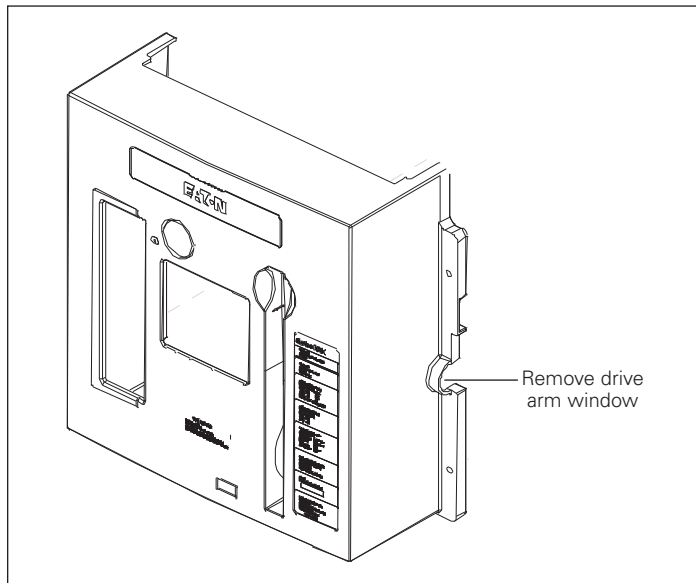

Figure 5. Details for Steps 1 and 2

Step 3

Install the drive arm (E) to the end of the pole shaft using an M6 x 35 mm flathead screw (F) as shown in **Figure 6**. Apply Loctite® Blue 242 to ensure that the screw cannot come loose during operation. The drive arm should be oriented as shown in **Figure 5**. Torque to 7,3–9,6 N·m (65–85 in·lb).

Step 4

Install the trip pin (A) to the trip bar using an M3 x 16 mm flathead screw (B) as shown in **Figure 6**. Apply Loctite Blue 242 to ensure that the screw cannot come loose during operation. Use a wrench to hold the trip lever during installation. Torque to 0,3–0,6 N·m (3–5 in·lb).

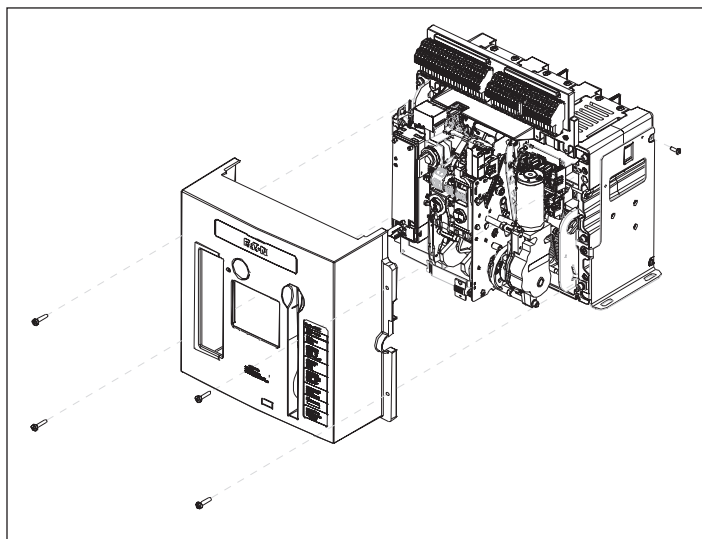

Figure 4. Details for Steps 1 and 2

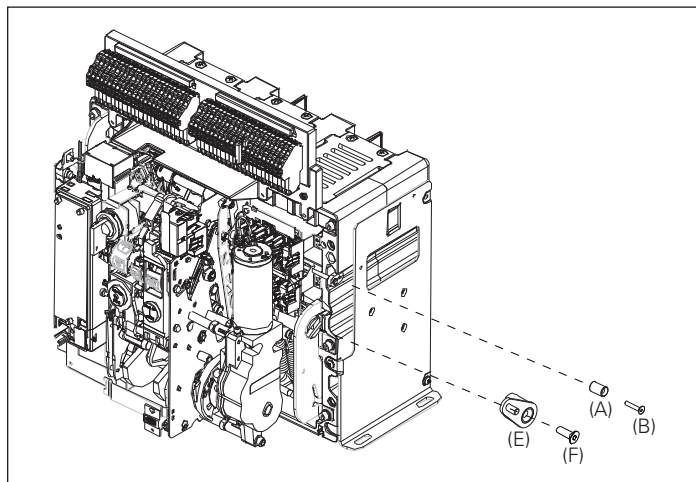

Figure 6. Details for Steps 3 and 4

Step 5

Fasten the interlock assembly (J) to the fixed mounting bracket (K) using four M6 x 12 mm hex bolts (C) and four lock washers (D) as shown in **Figure 7**. Torque to 4,5–5,6 N·m (40–50 in-lb).

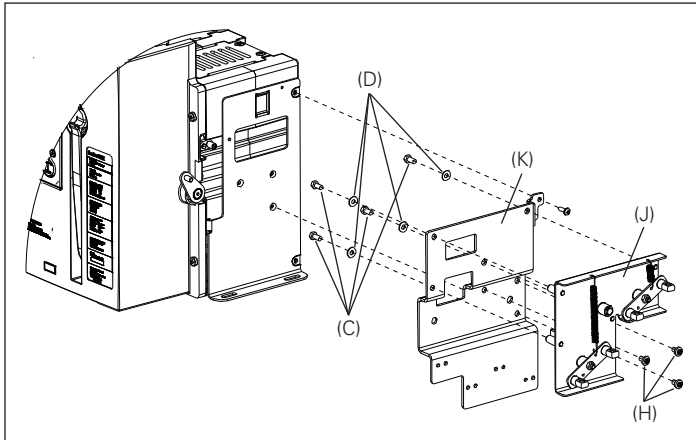

Figure 7. Details for Step 5

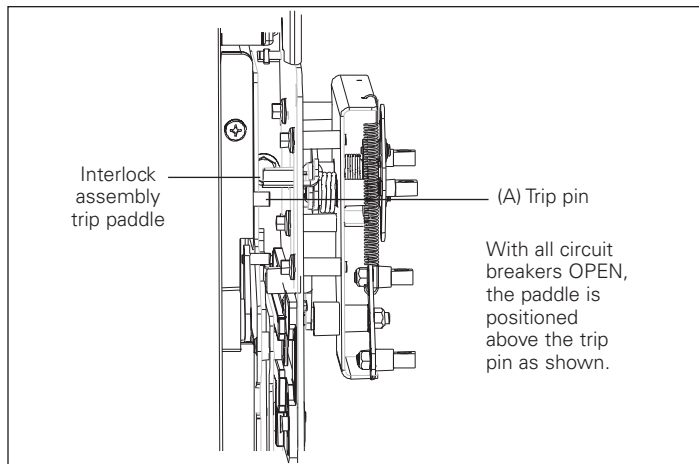

Figure 8. Details for Step 5

Step 6

Fasten the fixed mounting bracket (K) to the right side fixed breaker mounting foot using three M6 x 10 mm thread-forming screws (H) as shown in **Figure 9**. Torque to 7,3–9,6 N·m (65–85 in-lb). Ensure that once attached to the breaker, the trip paddle is above the trip pin on the trip bar as shown in **Figure 8**.

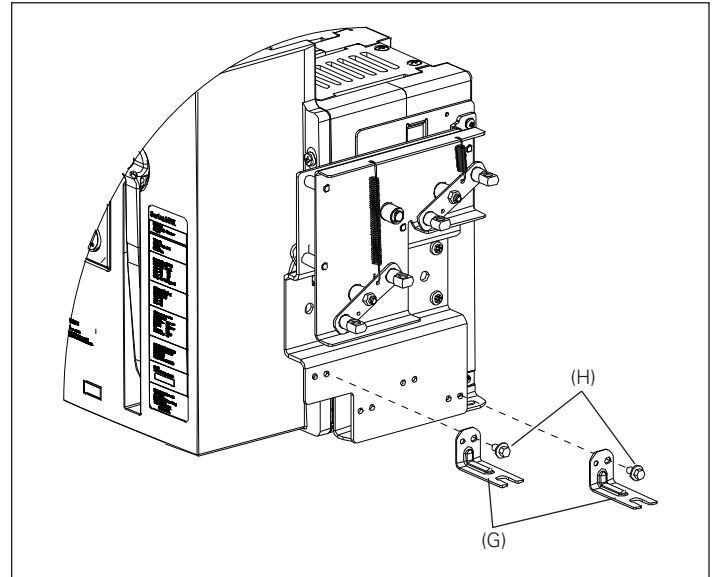

Figure 9. Details for Step 6

Step 7

Re-install M5 x 12 mm screw as shown in **Figure 7**. Torque to 2,2 N·m (20 in-lb).

Step 8

Fasten two cable brackets (G) to the right fixed mounting bracket (K) just below the interlock assembly (mounted in **Steps 5, 6, and 7**) using two M6 x 10 mm thread-forming screws (H) as shown in **Figure 9**. Torque to 7,3–9,6 N·m (65–85 in-lb).

Step 9

This step contains cable routing and installation procedures. Verify that cables move freely in their cable housings before installation. When attaching cables to swivel fittings, ensure that both ends of the cable are connected to pull swivel fittings (refer to **Figure 11**). For example, a cable connected to the drive lever pull swivel fitting on Breaker A must connect to the driven level pull swivel fitting on Breaker B.

ATTENTION

FIGURE 10 SHOWS THE TYPICAL CABLE ROUTING FOR TWO-WAY INTERLOCK CONFIGURATIONS. NOTICE THAT FOR THE TWO-WAY INTERLOCK CONFIGURATION, THE CABLES WILL BE ATTACHED TO THE PULL SWIVEL FITTINGS ON BOTH BREAKERS. THE CABLE MOUNTING ON THE PULL SWIVEL FITTINGS OF THE DRIVE AND DRIVEN LEVERS ARE DESCRIBED BELOW. TABLE 4 SHOWS THE TWO-WAY INTERLOCK LOGIC DEPENDING ON POSITION.

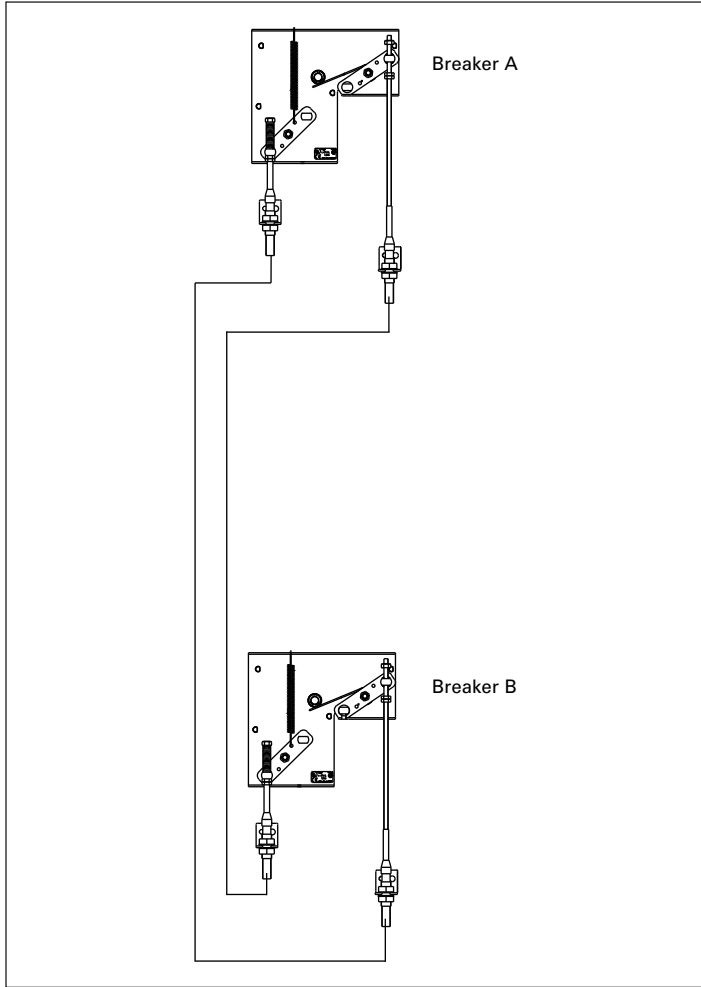

Figure 10. Cable routing for two-way interlock configurations

Table 4. Two-way interlock logic

Breaker A	Breaker B
0	0
1	0
0	1

0 = open
 1 = closed

Installation recommendations

- 102 mm (4 in) minimum allowable cable housing bend radius
- Use plastic wire ties / clamps to attach cable housing to structure after installation and adjustment
- Do not compress the cable housing
- Recheck to ensure cables move freely

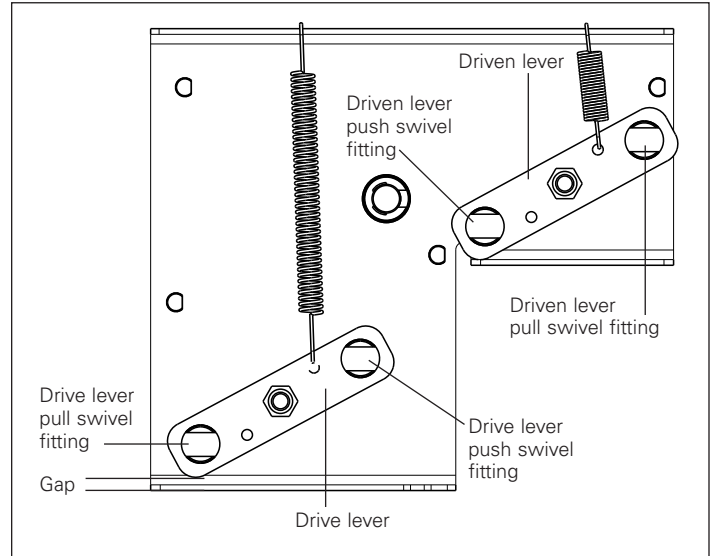

Figure 11. Push and pull swivel fitting identification

Step 10

This step describes how to first attach the drive (short rod) end of a cable to its interlock assembly and cable bracket (see **Figure 12**).

To attach the drive (short rod) end of a cable to the drive lever pull swivel fitting (refer to **Figure 11**), follow the directions below.

1. Remove upper nut, compression spring, and 38,1 mm (1,5 in) tube spacer from the end of rod of cable assembly.
2. Slide the rubber boot toward tip of the rod.
3. Unthread the outer bulkhead nut, and slide nut and lock washer toward the tip.
4. Insert the threaded end of rod into the swivel fitting.
5. Slide the smaller diameter portion of bulkhead fitting into the cable bracket slot, keeping one of the two lock washers with each bulkhead nut.
6. Raise the cable assembly until the threaded portion of bulkhead fitting enters the slotted hole in the cable bracket (threads show above bracket).
7. Bring the bulkhead washer and nut down to the threads and hand tighten.
8. Adjust the two bulkhead nuts to approximately center the threaded section of the bulkhead fitting on the cable mounting bracket.
9. Hand tighten the bulkhead nuts at this time.
10. Slide the rubber boot back into place over the end of bulkhead fitting.
11. Replace the 38,1 mm (1,5 in) tube spacer, compression spring, and upper nut on end of rod.
12. The lower nuts should be against the stop at the end of the thread and upper nut tightened against the tube spacer.
13. Hold the lower nuts and torque upper nut to 3,3–4,5 N·m (30–40 in-lb).

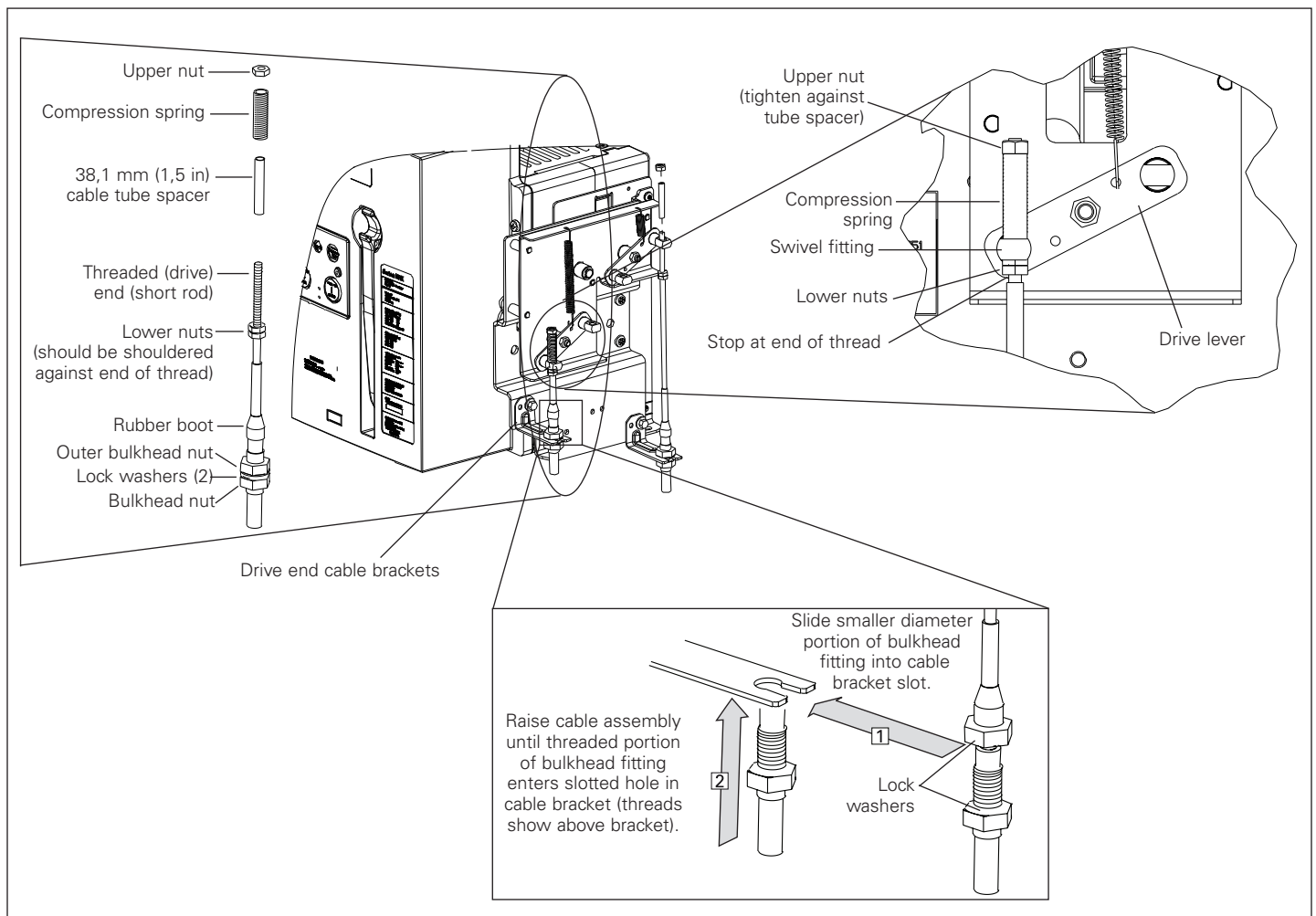

Figure 12. Details for Step 10: cable assembly drive (short rod) end mounting component identification, mounting cable assembly in cable bracket, and cable rod attachment to drive arm

Step 11

This step describes how to attach the driven (long rod) end of a cable attached to an interlock assembly on another breaker to the cable bracket and interlock assembly on this Type RF frame breaker. Refer to **Figure 10** and **Figure 11** for cable routing and the correct swivel fittings to which the cables are connected.

The driven (long rod) end of the cable is attached to its pull swivel fitting on the driven lever on this cable interlock assembly similarly to **Step 10** except the driven end does not utilize a compression spring between the swivel and nut. Remove and discard the 22,2 mm (0,875 inch) cable tube spacer (**N**) on the rod end of the cable assembly (**L**) and replace it with the 38,1 mm (1,5 inch) cable tube spacer (**M**). Install as shown in **Figure 13**.

Step 12

This step describes how to adjust the cables to ensure proper functionality of the cable interlock setup. Cable adjustments are made with the large bulkhead nuts **ONLY** and with all breakers **OPEN**. Nuts on the rod ends should not be moved.

Begin by adjusting or verifying that the threaded section of all bulkhead fittings are approximately centered on the cable mounting brackets, allowing for room to adjust in either direction. Hand tighten the nuts at this time.

Perform the initial adjustments on the driven (long rod) end of the cable. There should be a small clearance (see **Table 5**) between the upper nut and the face of the pull swivel on which it pulls (see **Figure 13**).

If there is **too much clearance**, adjust both the bulkhead nuts to retract the cable housing (move threaded portion down).

If there is **no clearance**, advance the cable housing in the same manner (move threaded portion up).

If **additional adjustment length** is needed, the bulkhead nuts on the other (drive) end of cable can be used.

When the proper clearance is attained on the driven end, torque both cable bulkhead nuts to 11–13 N·m (100–120 in-lb) without moving the bulkhead fittings.

After the driven end has been adjusted and the bulkhead nuts have been tightened, perform adjustments on the drive (short rod) end of the cable. Adjust the bulkhead nuts up (move threaded portion down) such that the gap between the drive lever and the interlock assembly base shown on **Figure 11** is less than 8 mm (0,32 in).

When the gap is less than 8 mm, torque the cable bulkhead nuts on both ends to 11–13 N·m (100–120 in-lb).

Table 5. Driven lever cable rod clearances

Driving breaker	Driven RF pull clearance
Type NF frame	< 1,6 mm (0,06 in)
Type RF frame	< 1,6 mm (0,06 in)
Magnum	< 10,0 mm (0,39 in)

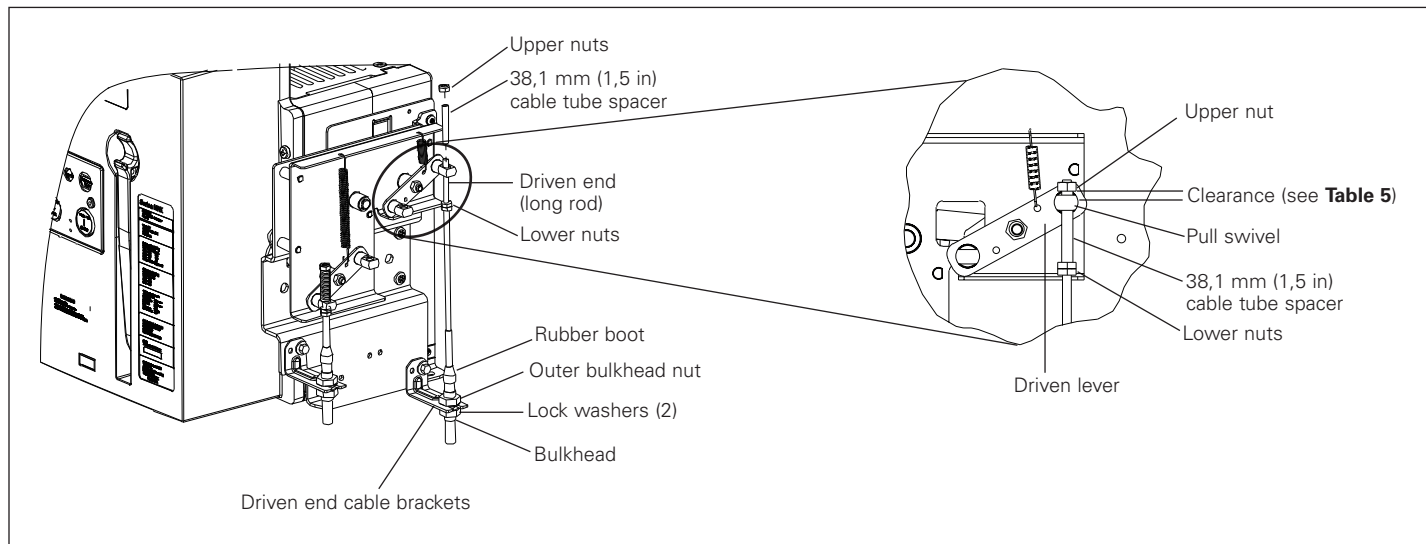

Figure 13. Details for Step 11: driven (long rod) end mounting component identification and Step 12 driven (long rod) end after adjustments

Functional test of interlock assembly

Refer to **Table 1** and **Figure 1** for breaker position in the interlock configuration. Begin test sequence with all breakers OPEN. For **Breaker A**, verify that the interlock assembly is positioned as shown in **Figure 14** while in the various states required by the steps below. For **Breaker B**, use the figure included in the information leaflet for the interlock kit installed on those breakers.

Check 1

CHARGE and CLOSE **Breaker A**.

- Verify that **Breaker A** closed using the OPEN/CLOSED indication and **Figure 14**
- Inspect driven lever on **Breaker B**. It should be positioned as shown in the figure of the information leaflet (IL) for the interlock kit installed on **Breaker B**
- CHARGE and attempt to CLOSE **Breaker B**. It should not respond to CLOSE attempt (no noise, spring discharge, or contact motion)
- If **Breaker B** responds to the CLOSE attempt, then additional adjustments may be required at the cable mounting brackets (refer to **Steps 10, 11, and 12**)

Check 2

Open **Breaker A** (verify it opens using the OPEN/CLOSED indication and **Figure 14**).

- The interlock should release
- CLOSE **Breaker B** (if already CHARGED). Verify that it closes using the OPEN/CLOSED indication
- **Breaker A** should remain in the OPEN position.
- OPEN **Breaker B**

Repeat **Checks 1** and **2** above on **Breaker B**

- Verify proper operation on both breakers (use **Figure 14** to verify when **Breaker A** is interlocked)

The mechanical interlock is now properly installed and adjusted. Utilize a light amount of supplied lubricant (**I**) if any interlock parts are sticky. This is only recommended if needed.

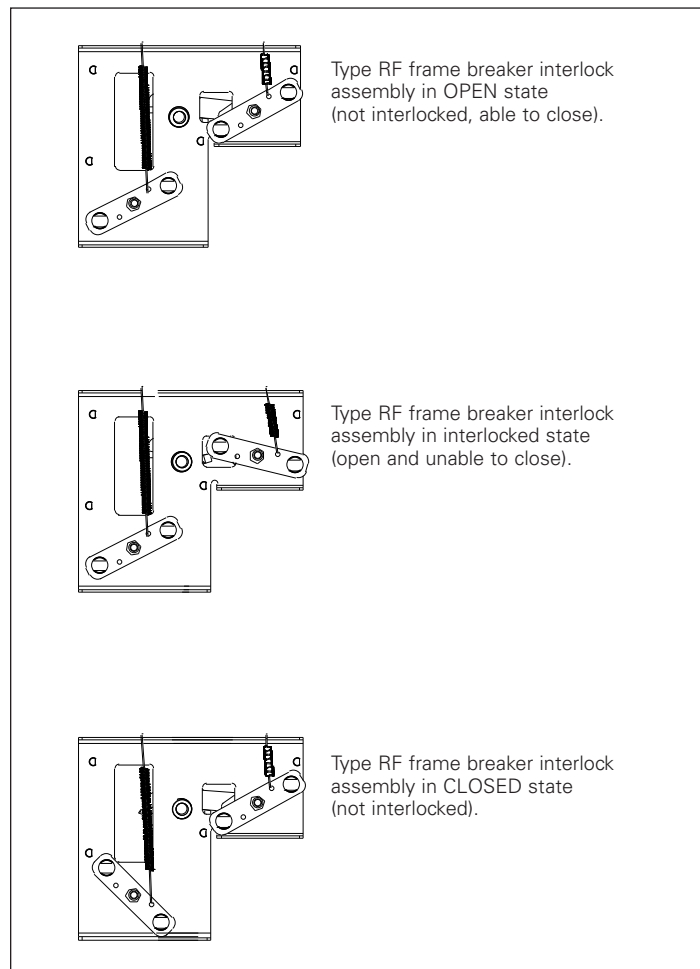

Figure 14. Position of interlock based on breaker state

Disclaimer of warranties and limitation of liability

The information, recommendations, descriptions, and safety notations in this document are based on Eaton's experience and judgment, and may not cover all contingencies. If further information is required, an Eaton sales office should be consulted.

Sale of the product shown in this literature is subject to the terms and conditions outlined in appropriate Eaton selling policies or other contractual agreement between Eaton and the purchaser.

THERE ARE NO UNDERSTANDINGS, AGREEMENTS, WARRANTIES, EXPRESSED OR IMPLIED, INCLUDING WARRANTIES OF FITNESS FOR A PARTICULAR PURPOSE OR MERCHANTABILITY, OTHER THAN THOSE SPECIFICALLY SET OUT IN ANY EXISTING CONTRACT BETWEEN THE PARTIES. ANY SUCH CONTRACT STATES THE ENTIRE OBLIGATION OF EATON. THE CONTENTS OF THIS DOCUMENT SHALL NOT BECOME PART OF OR MODIFY ANY CONTRACT BETWEEN THE PARTIES.

In no event will Eaton be responsible to the purchaser or user in contract, in tort (including negligence), strict liability or otherwise for any special, indirect, incidental or consequential damage or loss whatsoever, including but not limited to damage or loss of use of equipment, plant or power system, cost of capital, loss of power, additional expenses in the use of existing power facilities, or claims against the purchaser or user by its customers resulting from the use of the information, recommendations and description contained herein.

The information contained in this manual is subject to change without notice.

Eaton
1000 Eaton Boulevard
Cleveland, OH 44122
United States
Eaton.com

© 2015 Eaton
All Rights Reserved
Printed in USA
Publication No. IL0131071EN / Z16551
Part Number: IL0131071ENH02
April 2015