

Pushbutton cover kit – RF

Instructions apply to:

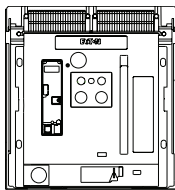

UL489 : PD-RF
IEC : PD-RF, IZMX40

WARNING

- (1) ONLY QUALIFIED ELECTRICAL PERSONNEL SHOULD BE PERMITTED TO WORK ON THE EQUIPMENT.
 - (2) ALWAYS DE-ENERGIZE PRIMARY AND SECONDARY CIRCUITS IF A CIRCUIT BREAKER CANNOT BE REMOVED TO A SAFE WORK LOCATION.
 - (3) DRAWOUT CIRCUIT BREAKERS SHOULD BE LEVERED (RACKED) OUT TO THE DISCONNECT POSITION.
 - (4) ALL CIRCUIT BREAKERS SHOULD BE SWITCHED TO THE OFF POSITION AND MECHANISM SPRINGS DISCHARGED.
- FAILURE TO FOLLOW THESE STEPS FOR ALL PROCEDURES DESCRIBED IN THIS INSTRUCTION LEAFLET COULD RESULT IN DEATH, BODILY INJURY, OR PROPERTY DAMAGE.

WARNING

THE INSTRUCTIONS CONTAINED IN THIS IL AND ON PRODUCT LABELS HAVE TO BE FOLLOWED. OBSERVE THE FIVE SAFETY RULES:

- DISCONNECTING
- ENSURE THAT DEVICES CANNOT BE ACCIDENTALLY RESTARTED
- VERIFY ISOLATION FROM THE SUPPLY
- EARTHING AND SHORT-CIRCUITING
- COVERING OR PROVIDING BARRIERS TO ADJACENT LIVE PARTS

DISCONNECT THE EQUIPMENT FROM THE SUPPLY. USE ONLY AUTHORIZED SPARE PARTS IN THE REPAIR OF THE EQUIPMENT. THE SPECIFIED MAINTENANCE INTERVALS AS WELL AS THE INSTRUCTIONS FOR REPAIR AND EXCHANGE MUST BE STRICTLY ADHERED TO PREVENT INJURY TO PERSONNEL AND DAMAGE TO THE SWITCHBOARD.

Section 1: General Information

A padlockable cover is designed to limit access to both the “ON” and “OFF” pushbuttons simultaneously, or individual pushbuttons as required. This is accomplished through the use of individual padlockable doors that close over the pushbuttons. The padlock provision will accommodate up to three (3) padlocks with shackle diameters of 3/16 inch to 5/16 inch (5-8 mm). A small hole is also provided to accommodate a wire seal. The Safe version has an added feature that presses down on the “OFF” button continuously, keeping the breaker in a “Safe-Off” state.

Padlockable covers are available in five different configurations:

1. Plastic Base and Clear Plastic Doors
2. Plastic Base and Metal Doors
3. Metal Base and Metal Doors
4. Metal Base and Clear Plastic Doors
5. Metal Base and Metal Doors with Safe-Off provision (**Figure 1**)

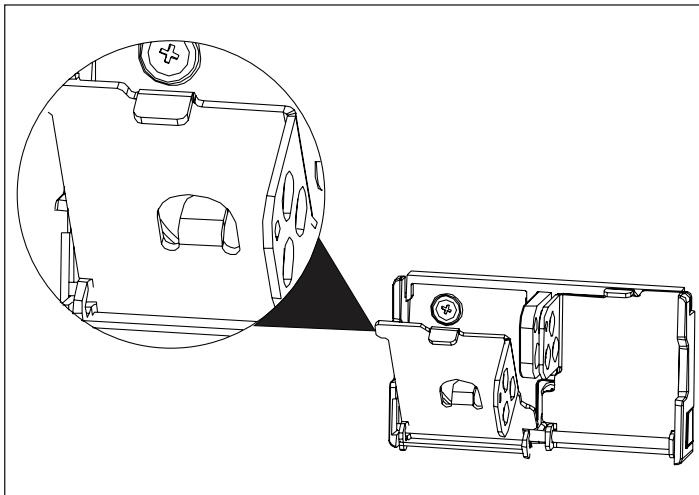

Figure 1. Safe-Off Provision

Kit Parts Identification

Refer to **Figure 2** for identification of the parts listed below:

- (A) Base (1)
- (B) Door (1) (installed in base)
- (C) M3 x 0.5mm 6mm long Mounting Screws (4)

Required Tools

Phillips Head Screwdriver #0 or #1

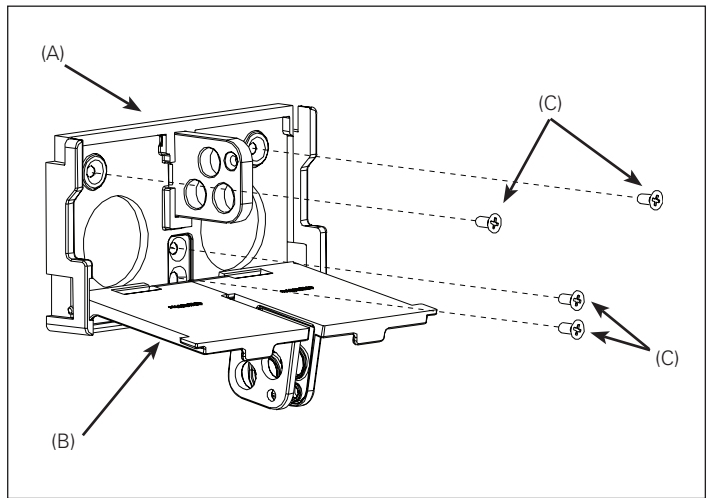

Figure 2. Contents of Kit

Section 2: Installation of Pushbutton Covers

Proceed with the following 6 steps:

Note: Only the plastic base with plastic doors configuration is shown in this section.

Step 1: Install one mounting screw (C) into the lower mounting hole on the breaker faceplate using 3-4 turns.

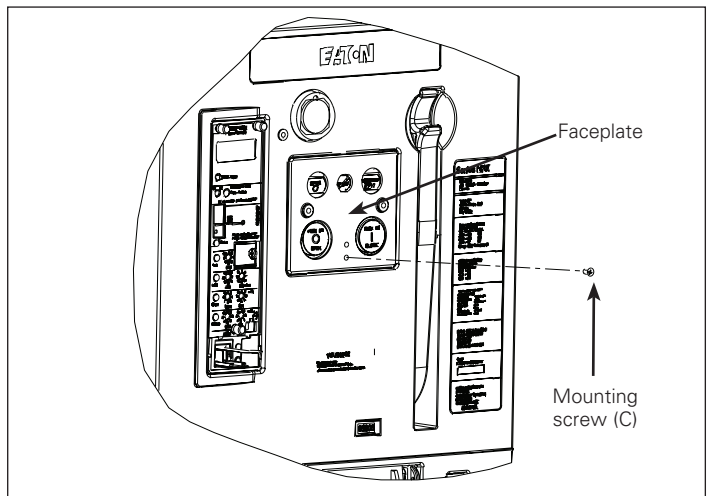

Figure 3. Step 1

Step 2: Slide the base (A) with installed doors (B) in the open position on the the mounting screw (C) installed in Step 1. To simplify the door opening, slide the doors all the way up to unlock them, then slide the doors all the way down so tabs on the doors slide into the groove space on base for the full open position.

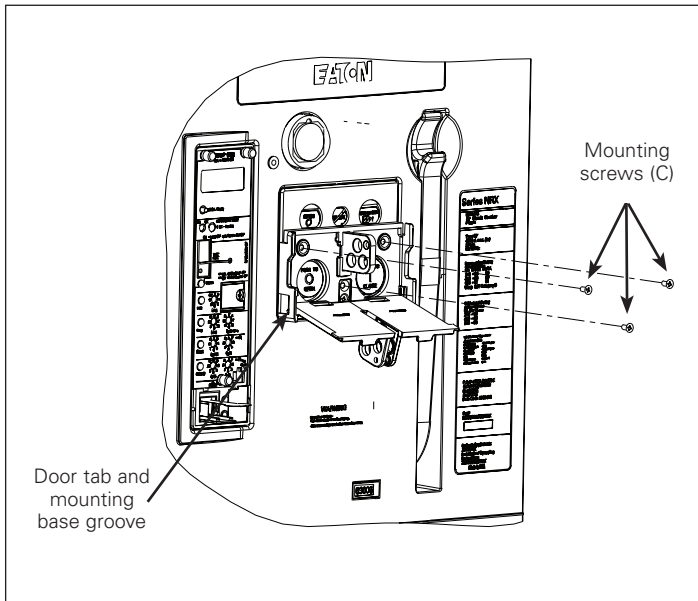

Figure 4. Steps 2-3

Step 3: Insert the second mounting screw (C) through the other mounting hole in the base and into the mounting hole in the faceplate. Torque both mounting screws to 6.0 lbs-in (0,68 Nm). Insert the remaining two mounting screws (C) through the indicated holes in the pushbutton cover and into the mounting holes in the faceplate. Torque both mounting screws to 6.0 lb-in (0,68 Nm). Refer to **Figure 4** for reference purposes.

Step 4: Once the pushbutton cover assembly is mounted on the breaker faceplate, the doors or individual doors are ready for use.

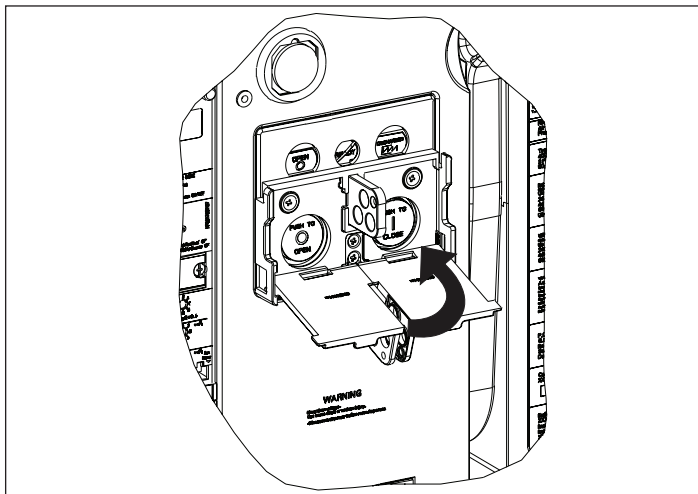

Figure 5. Step 4

Step 5: The doors can be closed and padlocked to prevent access to pushbuttons simultaneously or individually. In addition, a wire seal can also be used on the doors as required. For all padlock and wire seal holes to match, the doors must be all the way down so the door tabs are in the groove space on the base.

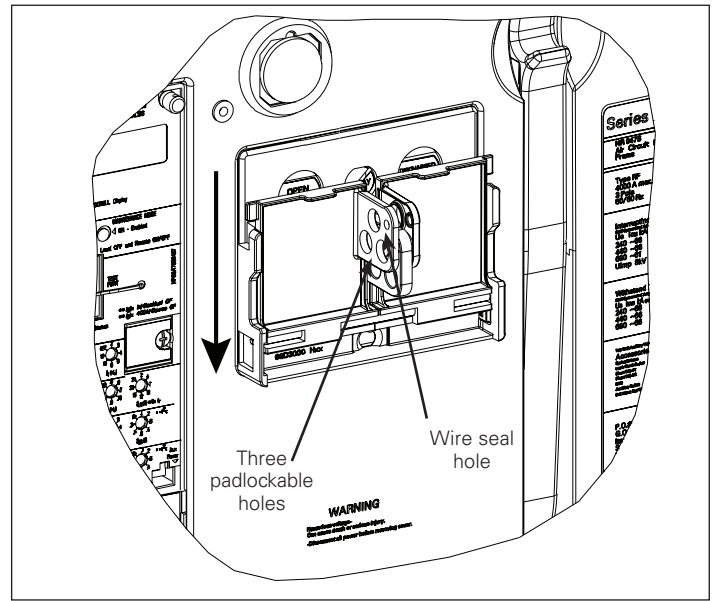

Figure 6. Step 5

Step 6: Up to three individual padlocks can be used to prevent the doors from being opened by unauthorized individuals. Keep in mind that padlocks must be removed to open any locked door.

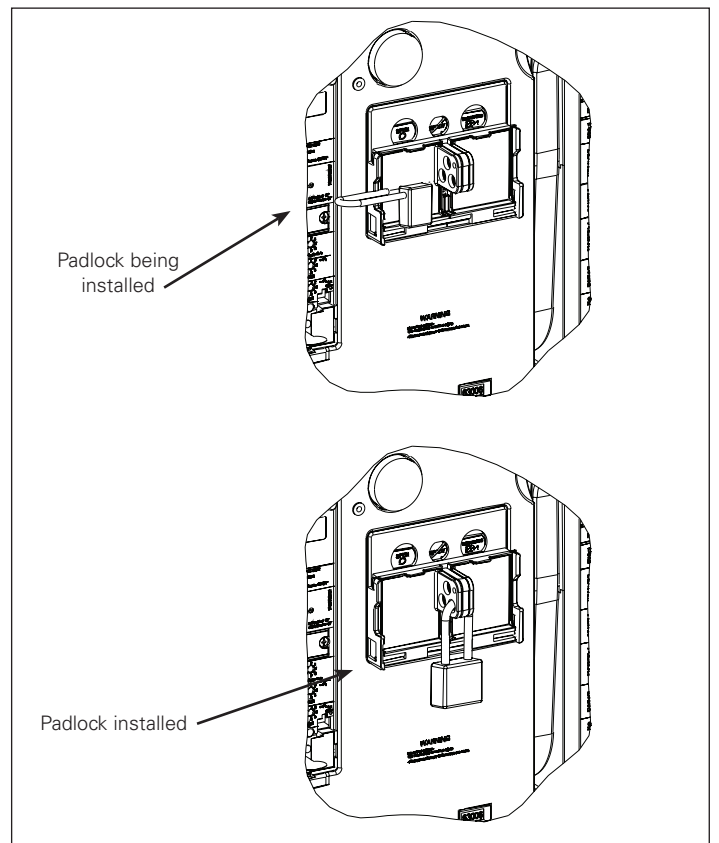

Figure 7. Step 6

Disclaimer of warranties and limitation of liability

The information, recommendations, descriptions, and safety notations in this document are based on Eaton Corporation's ("Eaton") experience and judgment, and may not cover all contingencies. If further information is required, an Eaton sales office should be consulted.

Sale of the product shown in this literature is subject to the terms and conditions outlined in appropriate Eaton selling policies or other contractual agreement between Eaton and the purchaser.

THERE ARE NO UNDERSTANDINGS, AGREEMENTS, WARRANTIES, EXPRESSED OR IMPLIED, INCLUDING WARRANTIES OF FITNESS FOR A PARTICULAR PURPOSE OR MERCHANTABILITY, OTHER THAN THOSE SPECIFICALLY SET OUT IN ANY EXISTING CONTRACT BETWEEN THE PARTIES. ANY SUCH CONTRACT STATES THE ENTIRE OBLIGATION OF EATON. THE CONTENTS OF THIS DOCUMENT SHALL NOT

BECOME PART OF OR MODIFY ANY CONTRACT BETWEEN THE PARTIES.

In no event will Eaton be responsible to the purchaser or user in contract, in tort (including negligence), strict liability, or otherwise for any special, indirect, incidental, or consequential damage or loss whatsoever, including but not limited to damage or loss of use of equipment, plant or power system, cost of capital, loss of power, additional expenses in the use of existing power facilities, or claims against the purchaser or user by its customers resulting from the use of the information, recommendations, and descriptions contained herein.

The information contained in this manual is subject to change without notice.

Eaton Corporation
Electrical Group
1000 Cherrington Parkway
Moon Township, PA 15108
United States
877-ETN-CARE (877-386-2273)
Eaton.com

© 2019 Eaton Corporation
All Rights Reserved
Printed in USA
Publication No. IL01301065EH01/ LNT56
Part No. IL01301065EH01
January 2019