

3-way multi-family cable interlock kit - types 31 & 33 - RF

Instructions apply to:

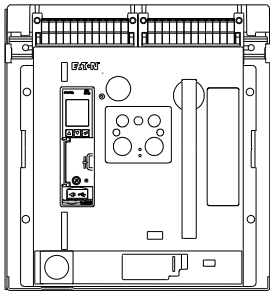

UL489 : PD-RF
IEC : PD-RF, IZMX40

Contents

Description	Page
General information	2
Installation	4
Functional test of interlock assembly	9

WARNING

(1) ONLY QUALIFIED ELECTRICAL PERSONNEL SHOULD BE PERMITTED TO WORK ON THE EQUIPMENT.

(2) ALWAYS DE-ENERGIZE PRIMARY AND SECONDARY CIRCUITS IF A CIRCUIT BREAKER CANNOT BE REMOVED TO A SAFE WORK LOCATION.

(3) DRAWOUT CIRCUIT BREAKERS SHOULD BE LEVERED (RACKED) OUT TO THE DISCONNECT POSITION.

(4) ALL CIRCUIT BREAKERS SHOULD BE SWITCHED TO THE OFF POSITION AND MECHANISM SPRINGS DISCHARGED.

FAILURE TO FOLLOW THESE WARNINGS FOR ALL PROCEDURES DESCRIBED IN THIS INSTRUCTION LEAFLET COULD RESULT IN DEATH, BODILY INJURY, OR PROPERTY DAMAGE.

WARNING

THE INSTRUCTIONS CONTAINED IN THIS IL AND ON PRODUCT LABELS HAVE TO BE FOLLOWED. OBSERVE THE FIVE SAFETY RULES:

- DISCONNECTING
- ENSURE THAT DEVICES CANNOT BE ACCIDENTALLY RESTARTED
- VERIFY ISOLATION FROM THE SUPPLY
- EARTHING AND SHORT-CIRCUITING
- COVERING OR PROVIDING BARRIERS TO ADJACENT LIVE PARTS

DISCONNECT THE EQUIPMENT FROM THE SUPPLY. USE ONLY AUTHORIZED SPARE PARTS IN THE REPAIR OF THE EQUIPMENT. THE SPECIFIED MAINTENANCE INTERVALS AS WELL AS THE INSTRUCTIONS FOR REPAIR AND EXCHANGE MUST BE STRICTLY ADHERED TO PREVENT INJURY TO PERSONNEL AND DAMAGE TO THE SWITCHBOARD.

General information

This information leaflet provides detailed installation instructions for installing and interconnecting one drawout Type RF frame breaker to another type of low voltage circuit breaker (LVCB) in any position (see A, B, C in **Table 1**) for a Type 31 or Type 33 interlock configuration as shown in **Figure 1**. When purchasing kits for a Type 31 or Type 33 interlock configuration setup, additional interlock kits (the types of interlock kits and the other breakers on which they can be installed that are compatible with this kit are listed in **Table 2**) are required for the other two breakers as well as the interconnecting cable kits (two or three are required depending on whether a Type 31 or Type 33 interlock configuration is desired, respectively).

For Type 31 or Type 33 interlock configurations, the mechanical interlock holds one or more of the breakers tripped or open (prevents closure) when some combination of the others are closed. A lever assembly is mounted on each breaker and interfaces with the pole shaft and trip bar. The lever assemblies are interconnected with cables provided in interconnecting cable kits (listed in **Table 3**) that are compatible with this interlock kit. The cable kits, purchased separately, each contain two cables and can be used for any orientation of the breakers according to the installation recommendations in **Step 7**.

Refer to **Figure 2** and **Figure 3** for identification of interlock kit and interconnecting cable kit contents, respectively.

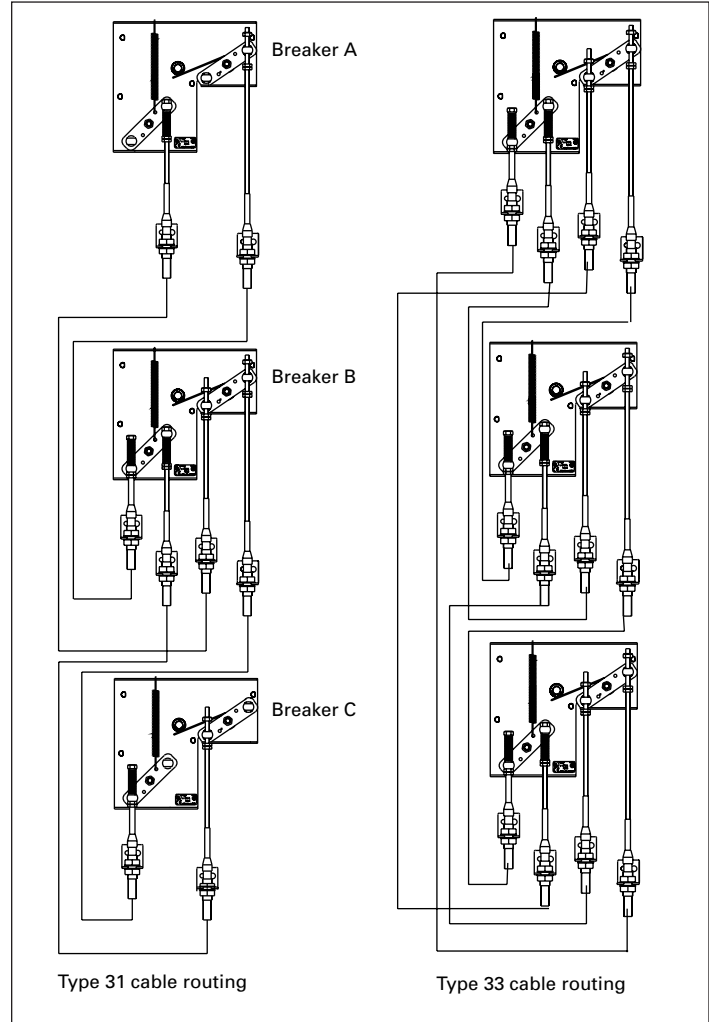

Figure 1. Cable routing for Type 31 and 33 interlock configurations

Table 1. Type 31 and 33 interlock logic

Type 33 (six cable)			Type 31 (four cable)		
Breaker	Breaker	Breaker	Breaker	Breaker	Breaker
A	B	C	A	B	C
Allowed states or conditions					
0	0	0	0	0	0
1	0	0	1	0	0
0	1	0	1	0	1
0	0	1	0	0	1
—	—	—	0	1	0

0 = open
1 = closed

Table 2. Interlock assembly kits for interconnected breakers

Interconnected breaker	Interlock assembly kit for fixed breaker	Interlock assembly kit for drawout breaker
Type NF frame	IZMX-MIL3133C-F16-2	IZMX-MIL3133C-W16-2
Type RF frame	IZMX-MIL3133C-F40-2	IZMX-MIL3133C-W40-2
Magnum DST, SB or IZM	MCI2W3W3133FX	MCI2W3W3133DO

Table 3. Interconnecting cable kits (two cables per kit) ^a

Cable kit length	Catalogue number
1,5 m (5 ft)	IZMX-MIL-CAB1520-2
1,8 m (6 ft)	IZMX-MIL-CAB1830-2
2,4 m (8 ft)	IZMX-MIL-CAB2440-2
3,0 m (10 ft)	IZMX-MIL-CAB3050-2

^a Cable kits are purchased separately as needed.

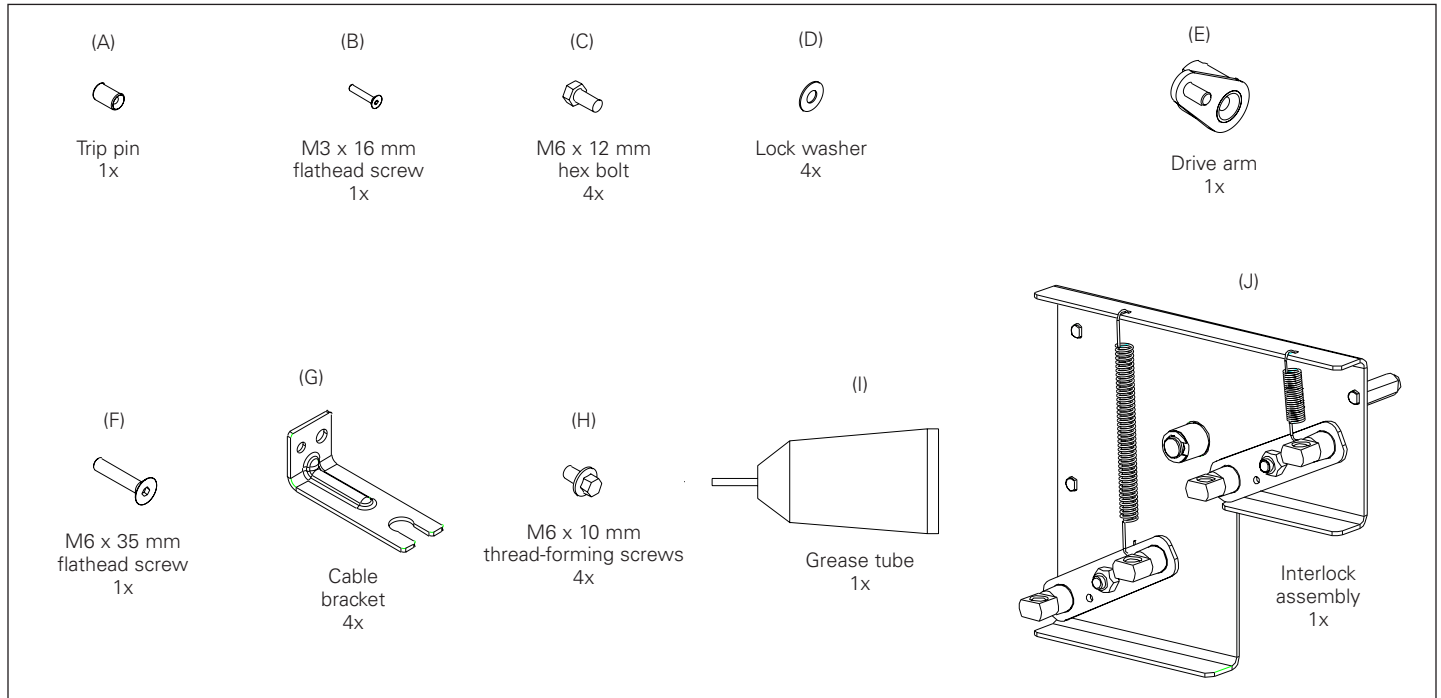

Figure 2. Interlock kit part identification, includes parts to install on a single drawout Type RF frame breaker and cassette (does not include cables)

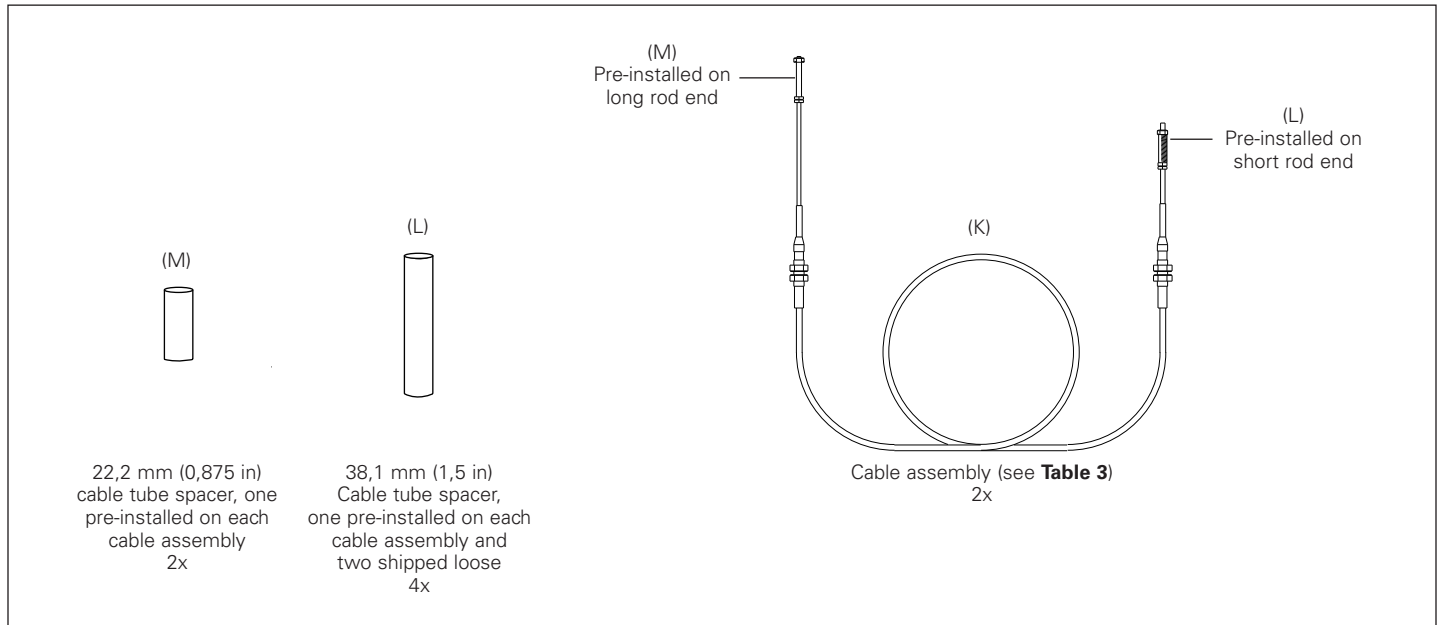

Figure 3. Interconnecting cable kit part identification (includes cables)

Installation

Required tools

- 10 mm hex socket
- 11/16-inch open-end wrench
- 3/8-inch open-end wrench
- 3/8-inch hex socket
- 2 mm Allen wrench
- Drive extension
- Adjustable wrench
- T15 Torx driver
- Measuring Instrument, in mm

Before proceeding with the following steps, ensure that all breakers are in the OPEN and DISCHARGED position.

Step 1

Remove the four screws (six for 4-pole breaker) holding the cover in place. Pull down on the charging handle and remove the front cover as shown in **Figure 4**. Remove drive arm window as shown in **Figure 5**. Either use a utility knife to cut the window from the cover, or use a punch and a small hammer to carefully punch out the window. Once the window is removed, use a small file to remove any burrs that remain. Make certain that all pieces and/or particles are cleaned up and removed before proceeding.

Step 2

Remove and retain the three screws holding the levering device side plate and then remove the levering device side plates.

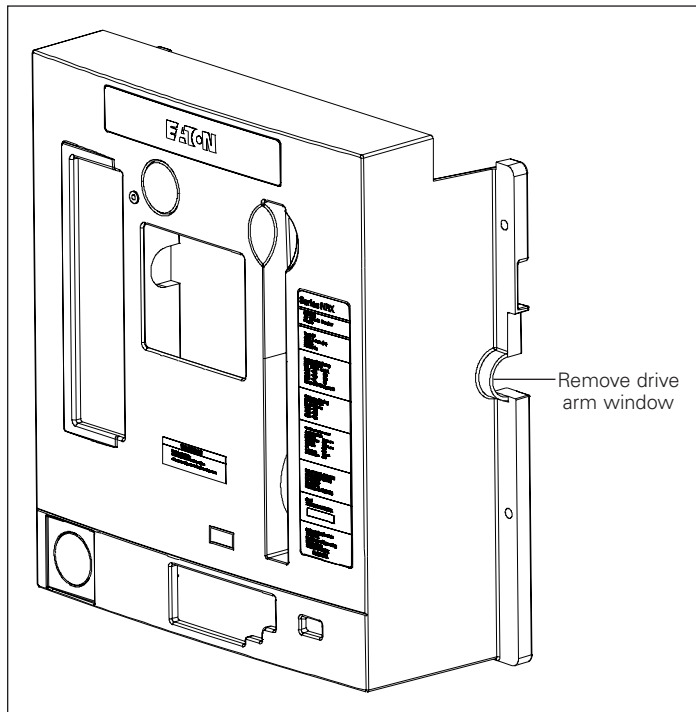

Figure 5. Details for Steps 1 and 2

Step 3

Install the drive arm (E) to the end of the pole shaft using an M6 x 35 mm flathead screw (F). Apply LoctiteT Blue 242 to ensure that the screw cannot come loose during operation. The drive arm should be oriented as shown in **Figure 6**. Torque to 7,3–9,6 N·m (65–85 in-lb).

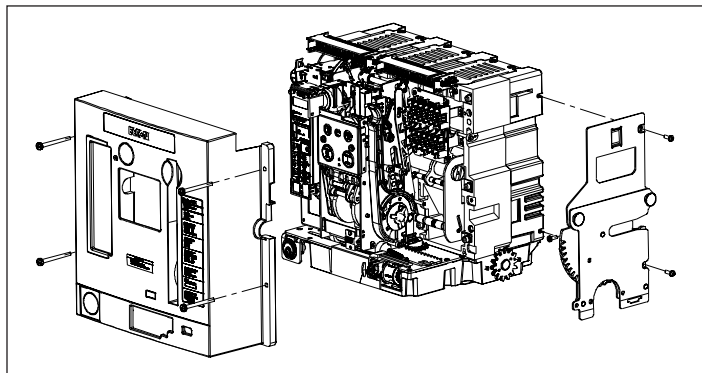

Figure 4. Details for Steps 1 and 2

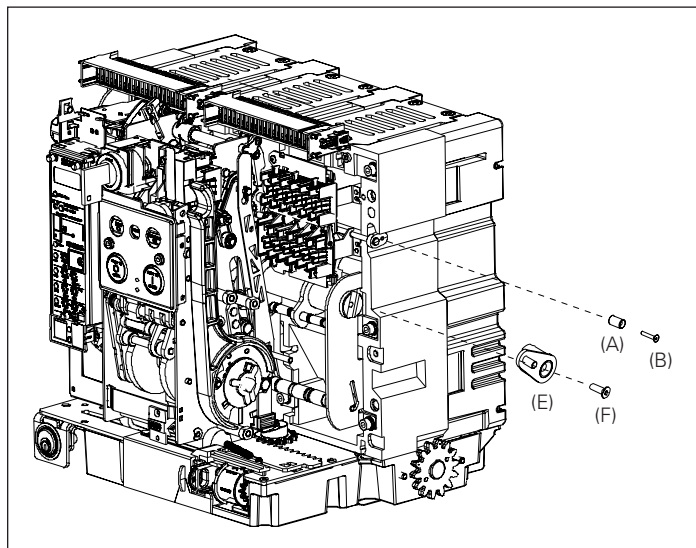

Figure 6. Details for Step 3 and 4

Step 4

Install the trip pin (A) to the trip bar using an M3 x 16 mm flathead screw (B) as shown in **Figure 6**. Apply Loctite Blue 242 to ensure that the screw cannot come loose during operation. Use a wrench to hold the trip lever during installation. Torque to 0,3–0,6 N·m (3–5 in-lb). Replace levering device side plate as shown in **Figure 7**.

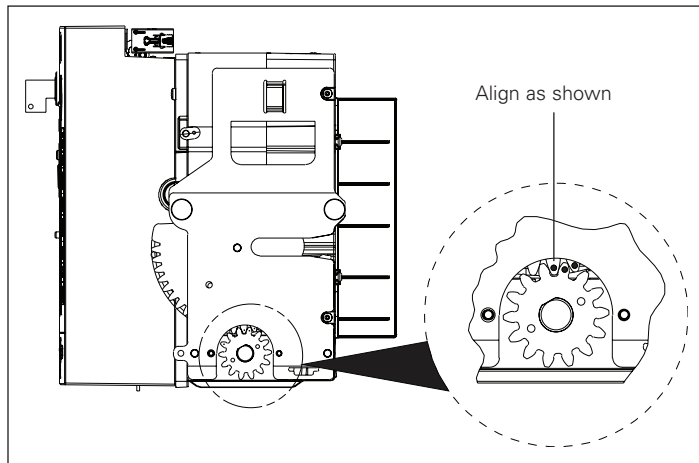

Figure 7. Details for Step 4

Step 5

Fasten the interlock assembly (J) to the drawout cassette's right-side sheet using four M6 x 12 mm hex bolts (C) and four lock washers (D) as shown in **Figure 8**. Torque to 4,5–5,6 N·m (40–50 in-lb). Ensure that once the breaker is racked in, the trip paddle is above the trip pin on the trip bar as shown in **Figure 9**.

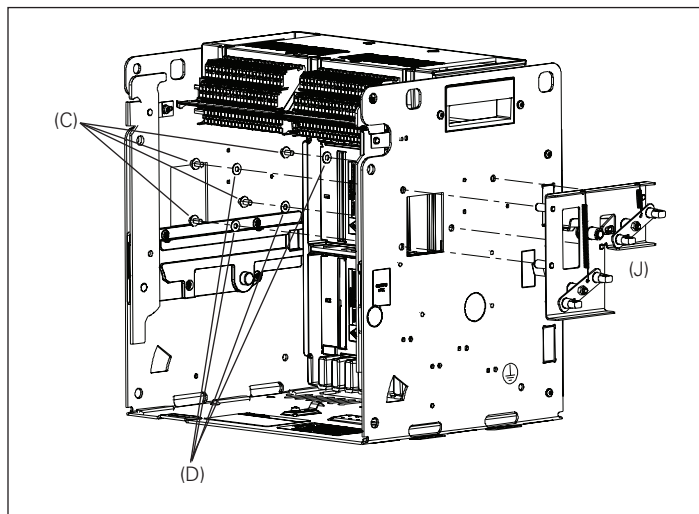

Figure 8. Details for Step 5

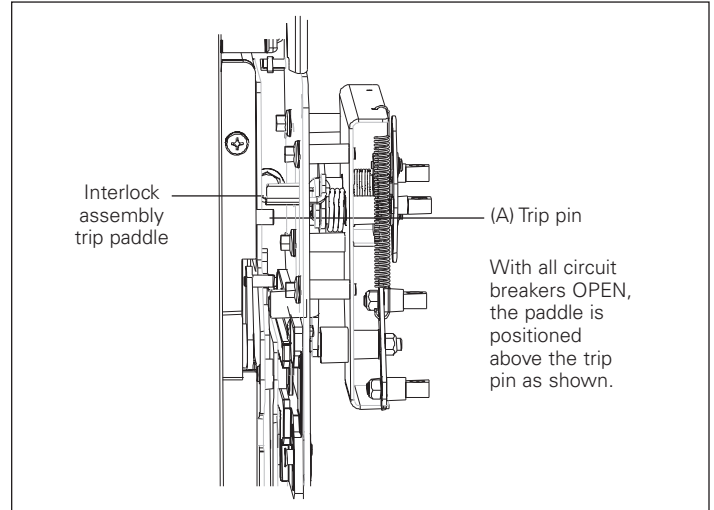

Figure 9. Details for Step 5

Step 6

Fasten four cable brackets (G) to the drawout cassette's right-side sheet just below the interlock assembly (mounted in **Step 5**) using four M6 x 10 mm thread-forming screws (H) as shown in **Figure 10**. Torque to 7,3–9,6 N·m (65–85 in-lb).

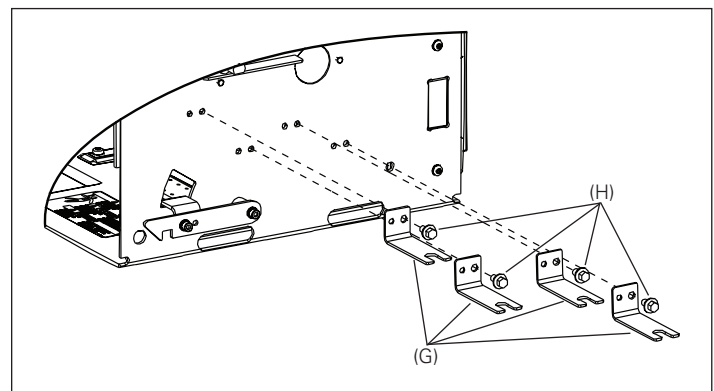

Figure 10. Details for Step 6

Step 7

This step contains cable routing and installation procedures. Verify that cables move freely in their cable housings before installation. When attaching cables to swivel fittings, ensure that both ends of the cable are connected to push swivel fittings or both ends of the cable are connected to pull swivel fittings (refer to **Figure 12**). For example, a cable connected to the drive lever pull swivel fitting on Breaker A must connect to the driven level pull swivel fitting on Breaker B.

ATTENTION

FIGURE 11 SHOWS THE TYPICAL CABLE ROUTING FOR TYPE 31 AND TYPE 33 INTERLOCK CONFIGURATIONS. NOTICE THAT DEPENDING ON THE POSITION OF THE BREAKER WITHIN THE INTERLOCK CONFIGURATION, THE CABLES WILL BE ATTACHED IN DIFFERENT LOCATIONS. THE CABLE MOUNTING ON BOTH POINTS OF THE DRIVE AND DRIVEN LEVERS ARE DESCRIBED BELOW. TABLE 4 SHOWS THE TYPE 31 AND TYPE 33 INTERLOCK LOGIC DEPENDING ON POSITION.

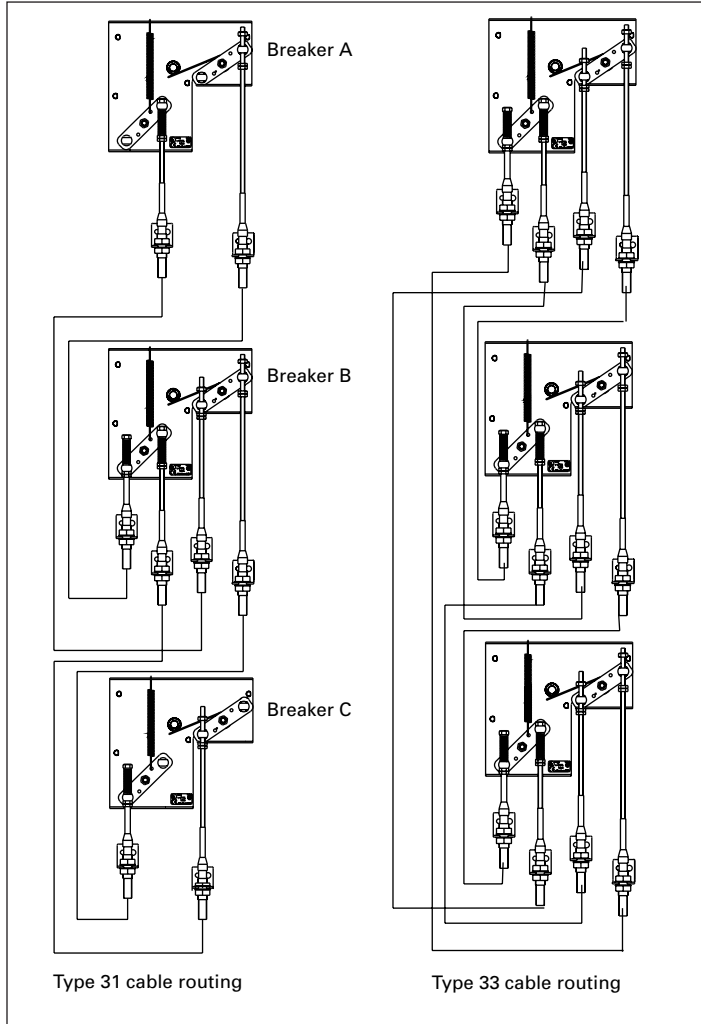

Figure 11. Cable routing for Type 31 and 33 interlock configurations

Table 4. Type 31 and 33 interlock logic

Type 33 (six cable)			Type 31 (four cable)		
Breaker	Breaker	Breaker	Breaker	Breaker	Breaker
A	B	C	A	B	C
Allowed states or conditions					
0	0	0	0	0	0
1	0	0	1	0	0
0	1	0	1	0	1
0	0	1	0	0	1
—	—	—	0	1	0

0 = open
1 = closed

Installation recommendations

- 102 mm (4 in) minimum allowable cable housing bend radius
- Use plastic wire ties / clamps to attach cable housing to structure after installation and adjustment
- Do not compress cable housing
- Recheck to ensure cables move freely

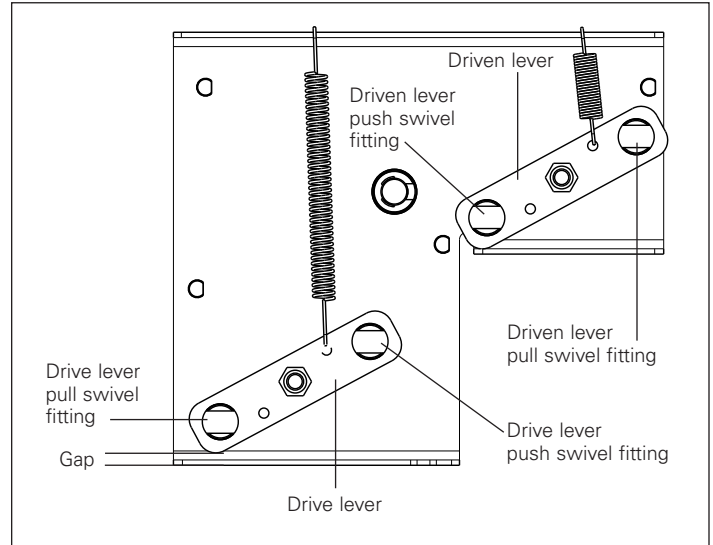

Figure 12. Push and pull swivel fitting identification

Step 8

This step describes how to first attach the drive (short rod) end of a cable to its interlock assembly and cable bracket. See **Figure 13**.

To attach the drive (short rod) end of a cable to the drive lever pull swivel fitting (refer to **Figure 12**), follow the directions below.

1. Remove upper nut, compression spring, and 38,1 mm (1,5 in) tube spacer from the end of rod of cable assembly.
2. Slide the rubber boot toward tip of the rod.
3. Unthread the outer bulkhead nut, and slide nut and lock washer toward the tip.
4. Insert the threaded end of rod into the swivel fitting.
5. Slide the smaller diameter portion of bulkhead fitting into the cable bracket slot, keeping one of the two lock washers with each bulkhead nut.
6. Raise the cable assembly until the threaded portion of bulkhead fitting enters the slotted hole in the cable bracket (threads show above bracket).
7. Bring the bulkhead washer and nut down to the threads and hand tighten.
8. Adjust the two bulkhead nuts to approximately center the threaded section of the bulkhead fitting on the cable mounting bracket.
9. Hand tighten the bulkhead nuts at this time.
10. Slide the rubber boot back into place over the end of bulkhead fitting.
11. Replace the 38,1 mm (1,5 in) tube spacer, compression spring, and upper nut on end of rod.
12. The lower nuts should be against the stop at the end of the thread and upper nut tightened against the tube spacer.
13. Hold the lower nuts and torque upper nut to 3,3–4,5 N·m (30–40 in-lb).

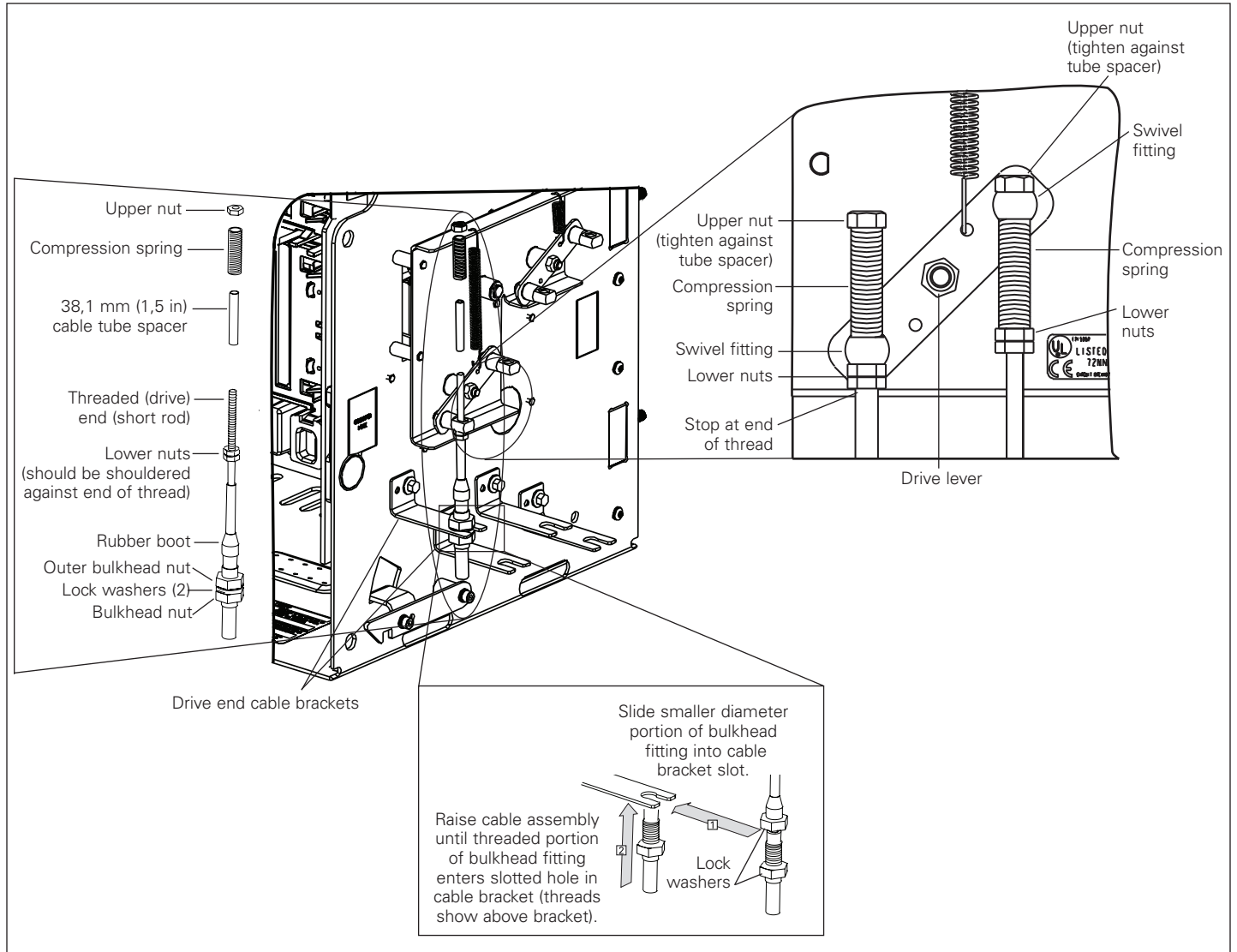

Figure 13. Details for Step 8: Cable assembly drive (short rod) end mounting component identification, mounting cable assembly in cable bracket, and cable rod attachment to drive arm

To attach the drive (short rod) end of a cable to the drive lever push swivel fitting (refer to **Figure 12**), follow the directions below (see **Figure 13**).

1. Remove the upper nut from the end of the rod of the cable assembly.
2. Slide the rubber boot toward the tip of rod.
3. Unthread the outer bulkhead nut, and slide the nut and lock washer toward tip.
4. Insert the threaded end of the rod with the 38,1 mm (1,5 in) tube spacer into the swivel fitting, ensuring that the compression spring remains between the lower nuts and the swivel.
5. Slide the smaller diameter portion of the bulkhead fitting into the cable bracket slot, keeping one of the two lock washers with each bulkhead nut.
6. Raise the cable assembly until the threaded portion of the bulkhead fitting enters the slotted hole in the cable bracket (threads show above bracket).
7. Bring the bulkhead washer and nut down to the threads and hand tighten.
8. Adjust the two bulkhead nuts to approximately the center of the threaded section of the bulkhead fitting on the cable mounting bracket.
9. Hand tighten the bulkhead nuts at this time.
10. Slide the rubber boot back into place over the end of bulkhead fitting.
11. The lower nuts should be against the stop at the end of thread and upper nut tightened against tube spacer.
12. Hold the lower nuts and torque the upper nut to 3,3–4,5 N·m (30–40 in-lb).

Step 9

This step describes how to attach the driven (long rod) end of a cable attached to an interlock assembly on another breaker to the cable bracket and interlock assembly on this Type RF frame breaker. Refer to **Figure 11** and **Figure 12** for cable routing and correct swivel fittings to which the cables are connected.

The driven (long rod) end of the cable is attached to the corresponding push or pull swivel fitting on the driven lever on this cable interlock assembly similarly to **Step 8** except the driven end does not utilize a compression spring between the swivel and the nut. Remove and discard the 22,2 mm (0,875 in) cable tube spacer (**M**) on the rod end of the cable assembly (**K**) and replace it with the 38,1 mm (1,5 in) cable tube spacer (**L**). Install as shown in **Figure 14**.

Step 10

This step describes how to adjust the cables to ensure proper functionality of the cable interlock setup. Cable adjustments are made with the large bulkhead nuts **ONLY** and with all breakers **OPEN**. Nuts on the rod ends should not be moved.

Begin by adjusting or verifying that the threaded section of all bulkhead fittings are approximately centered on the cable mounting brackets, allowing for room to adjust in either direction. Hand tighten the nuts at this time.

Perform initial adjustments on the driven (long rod) end of cable. There should be a small clearance (see **Table 5**) between the upper nut and the face of the pull swivel on which it pulls and between the lower nuts and the face of the push swivel on which it pushes (see **Figure 14**).

If there is **too much clearance**, adjust both bulkhead nuts to retract the cable housing (move threaded portion down).

If there is **no clearance**, advance the cable housing in the same manner (move threaded portion up).

If **additional adjustment length** is needed, the bulkhead nuts on the other (drive) end of cable can be used.

When the proper clearance is attained on the driven end, torque both cable bulkhead nuts to 11–13 N·m (100– 20 in-lb) without moving the bulkhead fittings.

After the driven end has been adjusted and the bulkhead nuts have been tightened, perform adjustments on the drive (short rod) end of the cable. Adjust the bulkhead nuts up (move threaded portion down) such that the gap between the drive lever and the interlock assembly base shown on **Figure 12** is less than 8 mm.

When the gap is less than 8 mm, torque the cable bulkhead nuts on both ends to 11–13 N·m (100–120 in-lb).

Table 5. Driven lever cable rod clearances

Driving breaker	Driven RF push clearance	Driven RF pull clearance
Type NF frame	< 1,6 mm (0,06 in)	< 1,6 mm (0,06 in)
Type RF frame	< 1,6 mm (0,06 in)	< 1,6 mm (0,06 in)
Magnum	< 4,5 mm (0,18 in)	< 10,0 mm (0,39 in)

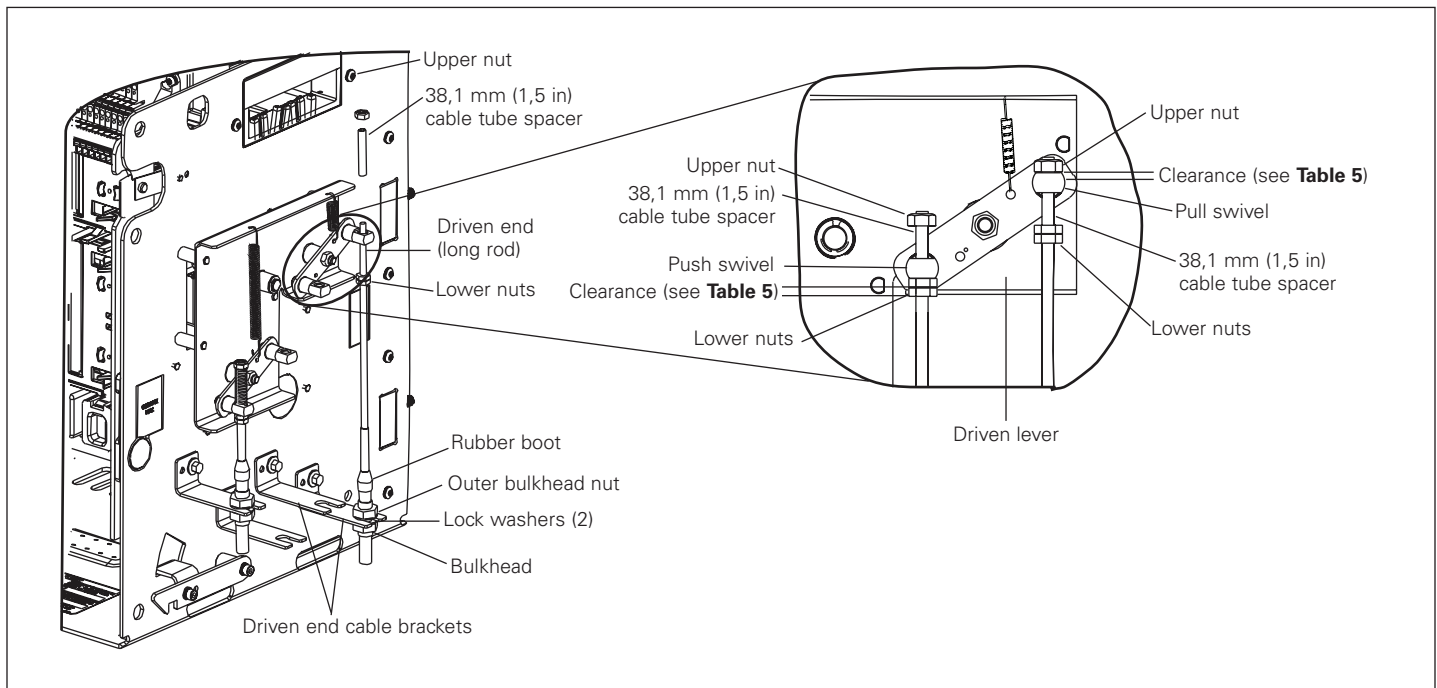

Figure 14. Details for Step 9: driven (long rod) end mounting component identification and Step 10 driven (long rod) end after adjustments

Functional test of interlock assembly

Refer to **Table 1** and **Figure 1** for breaker position in the interlock configuration. Begin test sequence with all breakers OPEN. For **Breaker A**, verify that the interlock assembly is positioned as shown in **Figure 15** while in the various states required by the steps below. For **Breakers B** and **C**, use the figure included in the information leaflet for the interlock kit installed on those breakers.

Type 31

Four-cable interlock assembly test. Refer to **Table 1** for logic details.

- CHARGE and CLOSE **Breaker A**
- CHARGE and attempt to CLOSE **Breaker B**. It should not respond to CLOSE attempt (no noise, spring discharge, or contact motion)
- CHARGE and CLOSE **Breaker C**. Verify that **Breaker A** remains CLOSED
- CHARGE and attempt to CLOSE **Breaker B** again. It should still not respond to CLOSE attempt (no noise, spring discharge, or contact motion)
- OPEN **Breaker A**. Verify that **Breaker C** is still CLOSED. CHARGE and attempt to CLOSE **Breaker B**. It should still not respond to CLOSE attempt (no noise, spring discharge, or contact motion)
- OPEN **Breaker C**. All breakers should now be OPEN
- CHARGE and CLOSE **Breaker B**. CHARGE and attempt to CLOSE **Breakers A** and **C**. Verify that they do not respond to CLOSE attempt (no noise, spring discharge, or contact motion)

Type 33

Six-cable interlock assembly test. Refer to **Table 1** for logic details.

- CHARGE and CLOSE **Breaker A**
- CHARGE and attempt to CLOSE **Breakers B** and **C**. Verify that neither breaker responds to CLOSE attempt (no noise, spring discharge, or contact motion)
- OPEN **Breaker A**. The interlock should release
- Repeat above test on **Breaker B** using **B** for **A**, **C** for **B**, and **A** for **C** and **Breaker C** using **C** for **A**, **A** for **B**, and **B** for **C**

The mechanical interlock is now properly installed and adjusted. Use a light amount of supplied lubricant (**G**) if any interlock parts are sticky or do not fully reset. This is only recommended if needed.

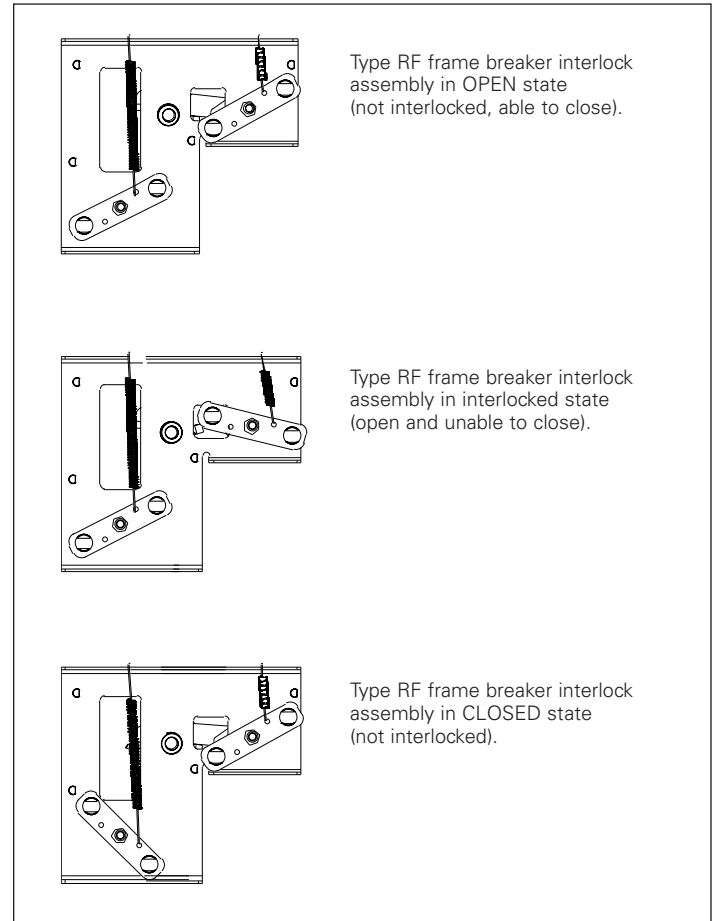

Figure 15. Position of interlock based on breaker state

Disclaimer of warranties and limitation of liability

The information, recommendations, descriptions, and safety notations in this document are based on Eaton's experience and judgment, and may not cover all contingencies. If further information is required, an Eaton sales office should be consulted.

Sale of the product shown in this literature is subject to the terms and conditions outlined in appropriate Eaton selling policies or other contractual agreement between Eaton and the purchaser.

THERE ARE NO UNDERSTANDINGS, AGREEMENTS, WARRANTIES, EXPRESSED OR IMPLIED, INCLUDING WARRANTIES OF FITNESS FOR A PARTICULAR PURPOSE OR MERCHANTABILITY, OTHER THAN THOSE SPECIFICALLY SET OUT IN ANY EXISTING CONTRACT BETWEEN THE PARTIES. ANY SUCH CONTRACT STATES THE ENTIRE OBLIGATION OF EATON. THE CONTENTS OF THIS DOCUMENT SHALL NOT BECOME PART OF OR MODIFY ANY CONTRACT BETWEEN THE PARTIES.

In no event will Eaton be responsible to the purchaser or user in contract, in tort (including negligence), strict liability or otherwise for any special, indirect, incidental or consequential damage or loss whatsoever, including but not limited to damage or loss of use of equipment, plant or power system, cost of capital, loss of power, additional expenses in the use of existing power facilities, or claims against the purchaser or user by its customers resulting from the use of the information, recommendations and description contained herein.

The information contained in this manual is subject to change without notice.

Eaton
1000 Eaton Boulevard
Cleveland, OH 44122
United States
Eaton.com

© 2019 Eaton
All Rights Reserved
Printed in USA
Publication No. IL0131072EN / LNT32
Part Number: IL0131072ENH03
January 2019