

Instructions for secondary terminal blocks

Instructions Apply to:

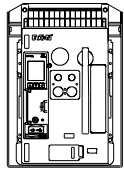

UL489 : PD-NF
IEC : PD-NF, IZMX16

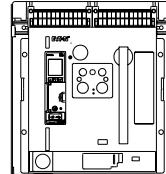

UL489 : PD-RF
IEC : PD-RF, IZMX40

⚠ WARNING

- (1) ONLY QUALIFIED ELECTRICAL PERSONNEL SHOULD BE PERMITTED TO WORK ON THE EQUIPMENT.
 - (2) ALWAYS DE-ENERGIZE PRIMARY AND SECONDARY CIRCUITS IF A CIRCUIT BREAKER CANNOT BE REMOVED TO A SAFE WORK LOCATION.
 - (3) DRAWOUT CIRCUIT BREAKERS SHOULD BE LEVERED (RACKED) OUT TO THE DISCONNECT POSITION.
 - (4) ALL CIRCUIT BREAKERS SHOULD BE SWITCHED TO THE OFF POSITION AND MECHANISM SPRINGS DISCHARGED.
- FAILURE TO FOLLOW THESE STEPS FOR ALL PROCEDURES DESCRIBED IN THIS INSTRUCTION LEAFLET COULD RESULT IN DEATH, BODILY INJURY, OR PROPERTY DAMAGE.

⚠ WARNING

THE INSTRUCTIONS CONTAINED IN THIS IL AND ON PRODUCT LABELS HAVE TO BE FOLLOWED. OBSERVE THE FIVE SAFETY RULES:

- DISCONNECTING
- ENSURE THAT DEVICES CANNOT BE ACCIDENTALLY RESTARTED
- VERIFY ISOLATION FROM THE SUPPLY
- EARTHING AND SHORT-CIRCUITING
- COVERING OR PROVIDING BARRIERS TO ADJACENT LIVE PARTS

DISCONNECT THE EQUIPMENT FROM THE SUPPLY. USE ONLY AUTHORIZED SPARE PARTS IN THE REPAIR OF THE EQUIPMENT. THE SPECIFIED MAINTENANCE INTERVALS AS WELL AS THE INSTRUCTIONS FOR REPAIR AND EXCHANGE MUST BE STRICTLY ADHERED TO PREVENT INJURY TO PERSONNEL AND DAMAGE TO THE SWITCHBOARD.

Section 1: General Information

A maximum of 14 terminal blocks providing 56 secondary contact points are available in one cradle on the NF Frame circuit breaker. The RF Frame circuit breaker is available with a maximum of 24 terminal blocks providing 96 secondary contact points in two individual cradles. The number of terminal blocks mounted depends on a number of considerations, such as whether the circuit breaker is electrically or manually operated and how many features are required. For example, the shunt trip device has two leads and uses one side of a terminal block. Other devices, such as a motor operator, has three leads and requires two terminal blocks. Each connection point is permanently identified. Terminal blocks can be individually mounted and hence contact positions may be empty.

For drawout circuit breakers, secondary terminal blocks (Figure 1) are mounted onto an insulated support frame on the top front portion of the drawout cassette.

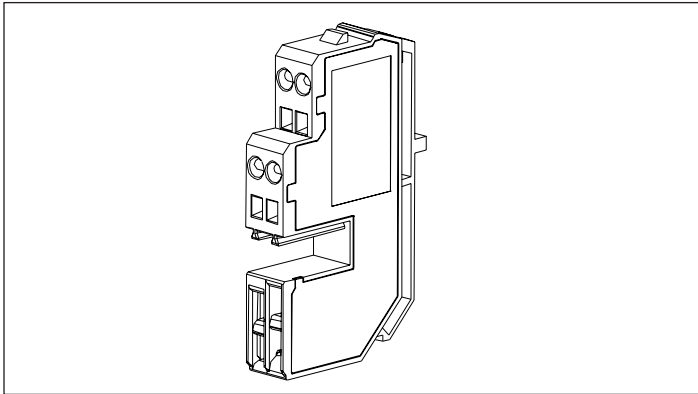

Figure 1. Drawout Terminal Block.

For fixed-mounted circuit breakers, secondary terminal blocks (Figure 2) mount onto an insulated support frame.

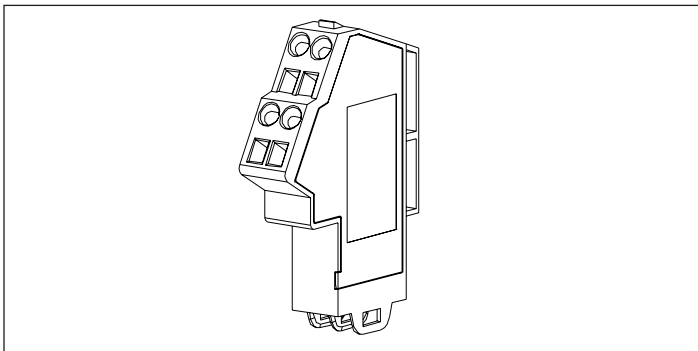

Figure 2. Fixed Terminal Block.

Electrical accessory leads are tagged with numbers associated with the applicable connection diagram. Leads are also supplied with keyed secondary connector plugs to ensure proper connections (Figure 3).

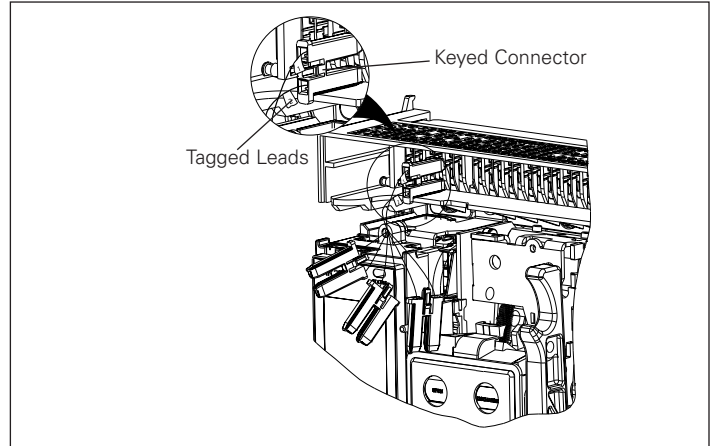

Figure 3. Leads and Connectors (Drawout Configuration Shown).

Secondary connections are made by plugging the connector plugs into the appropriate location. A connector plug already connected can be removed by squeezing two release tabs together with small needle nose pliers and pulling out (Figure 4).

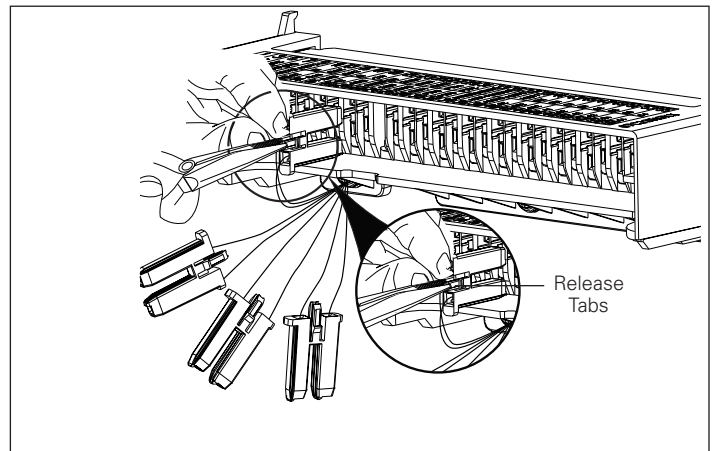

Figure 4. Connector Plug Removal.

Customer wiring is done using tension clamp terminations. Refer to manuals MN013001EN (12m x 16 / Type NF Frame) or MN013002EN (12m x 40 / Type RF Frame) for an applicable connection diagrams, other specific wiring, and additional secondary contact information for all circuit breakers.

Section 2: Installation and Removal of Fixed Terminal Blocks

Note: Many illustrations use the NF Frame circuit breaker for illustrative purposes only. The RF Frame circuit breaker is handled in a similar fashion.

Proceed with the following eight steps.

Step 1: Remove the four screws holding the front cover in place (two on each side of the cover).

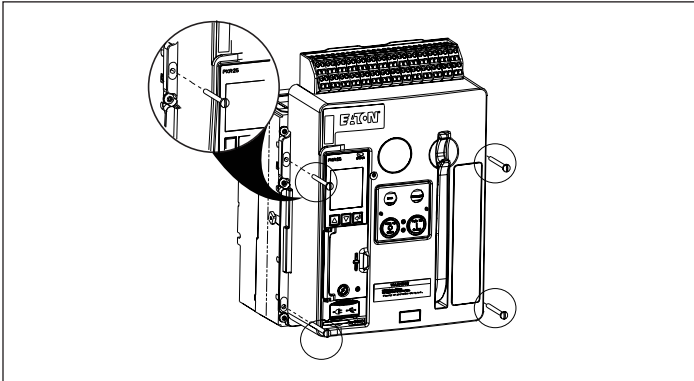

Figure 5. Step 1.

Step 2: Remove the front cover. Pull down on the charging handle to simplify removal.

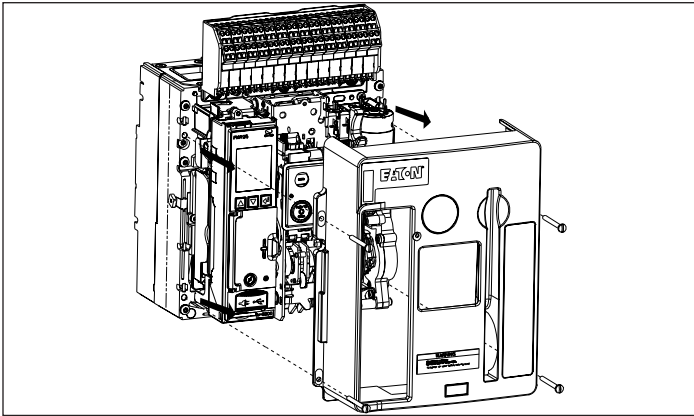

Figure 6. Step 2.

Step 3: Become familiar with the fixed terminal block mounting plate where secondary connections are made.

Note: Secondary connection points have numerical and descriptive laser-etched identifications.

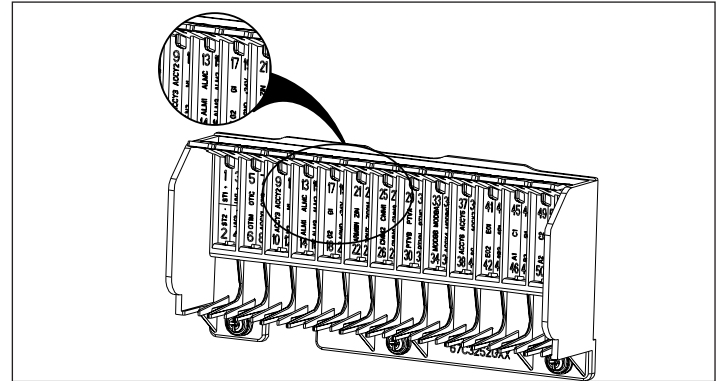

Figure 7. Step 3.

Step 4: Plug the accessory connector plug into fixed secondary terminal block.

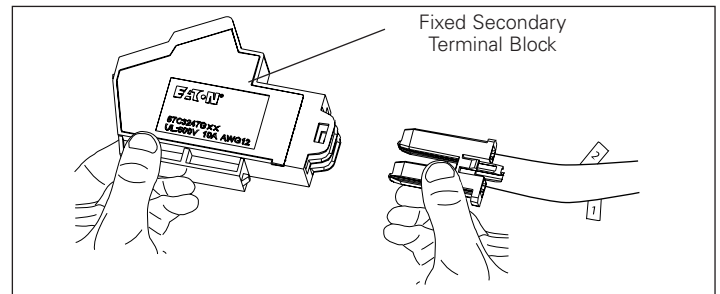

Figure 8. Step 4.

Step 5: Identify correct mounting location on fixed terminal block mounting plate for mounting fixed secondary terminal block. First insert the bottom end of the fixed secondary terminal block into the proper location on the mounting plate.

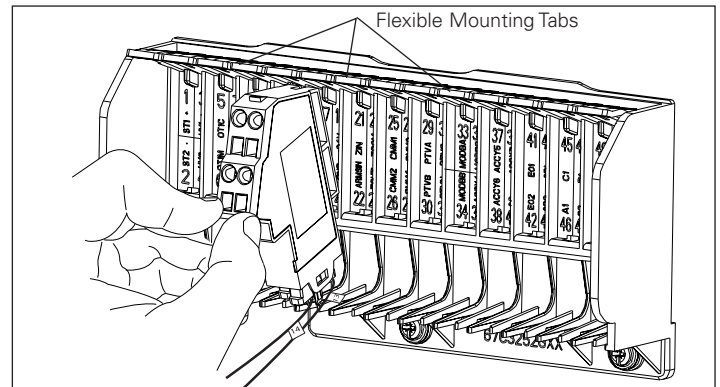

Figure 9. Step 5.

Step 6: Rotate the top end of the terminal block in until it engages the appropriate flexible mounting tab at the top of the mounting plate with a clicking sound.

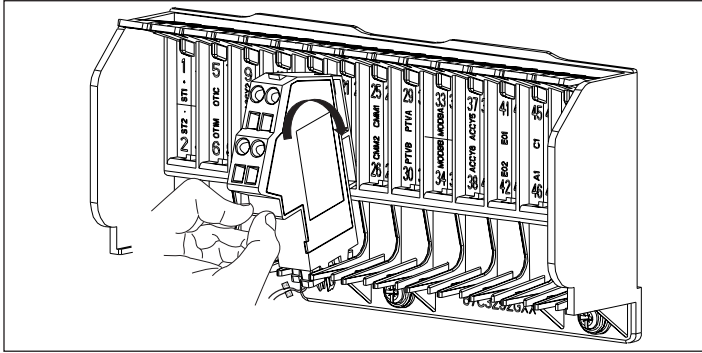

Figure 10. Step 6.

Step 7: To remove a fixed secondary terminal block, lift up on the small flexible mounting tab at the top of fixed terminal block mounting plate, and rotate the terminal block out in the opposite direction shown in Step 6.

IMPORTANT

KEEP IN MIND THAT TO REMOVE AN ACCESSORY PLUG ON A FIXED CIRCUIT BREAKER, THE APPROPRIATE FIXED SECONDARY TERMINAL BLOCK MUST FIRST BE REMOVED. ONCE THE TERMINAL BLOCK IS REMOVED, THE ACCESSORY CONNECTOR PLUG CAN BE UNPLUGGED FROM THE BOTTOM OF THE TERMINAL BLOCK. REFER TO FIGURE 4 IN SECTION 1 FOR ASSISTANCE WITH THE REMOVAL.

Step 8: Once all terminal blocks are securely mounted, replace the front cover and secure it in place with the four mounting screws previously removed in Step 1.

Section 3: Installation and Removal of Drawout Terminal Blocks

IMPORTANT

KEEP IN MIND THAT THE SECONDARY TERMINAL BLOCKS ASSOCIATED WITH DRAWOUT CIRCUIT BREAKERS ARE MOUNTED ON THE BREAKER'S DRAWOUT CASSETTE (FIGURE 11). ACCESSORY SECONDARY PLUGS PLUG INTO A SECONDARY PLUG HOUSING MOUNTED ON THE TOP FRONT OF THE CIRCUIT BREAKER (FIGURE 12). AS SUCH, SECONDARY CONNECTIONS ARE AUTOMATICALLY MADE OR DISCONNECTED DURING THE LEVERING (RACKING) PROCESS AS THE SECONDARY PLUG HOUSING ON THE BREAKER ENGAGES OR DISENGAGES THE SECONDARY TERMINAL BLOCKS MOUNTED ON THE DRAWOUT CASSETTE. FOR THIS REASON, ACCESSORY SECONDARY PLUGS DO NOT HAVE TO BE UNPLUGGED TO ADD OR REMOVE TERMINAL BLOCKS. REFER TO FIGURES 3 AND 4 OF SECTION 1 AND THE ASSOCIATED COPY FOR ASSISTANCE WITH CONNECTING OR DISCONNECTING ACCESSORY SECONDARY PLUGS.

Note: Many illustrations use the NF Frame cassette for illustrative purposes only. The RF Frame cassette is handled in a similar fashion.

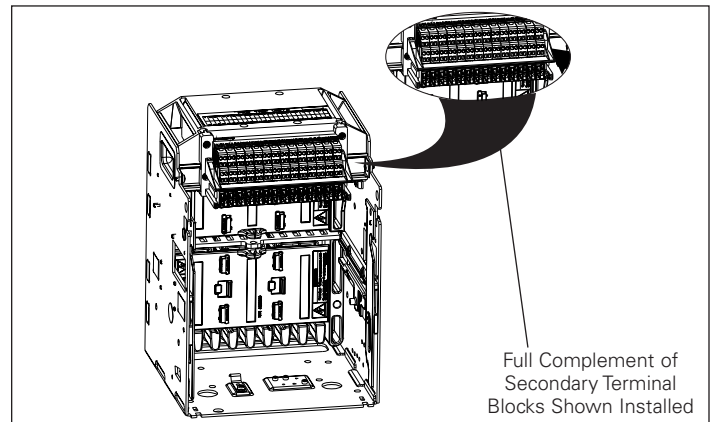

Figure 11. Cassette-Mounted Terminal Blocks NF Frame.

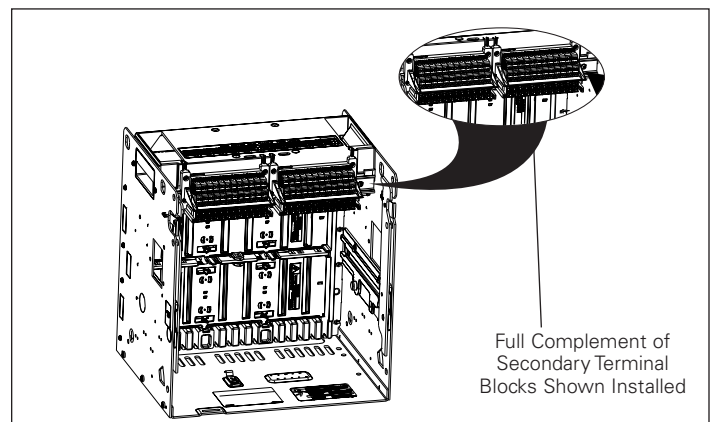

Figure 11A. Cassette-Mounted Terminal Blocks RF Frame.

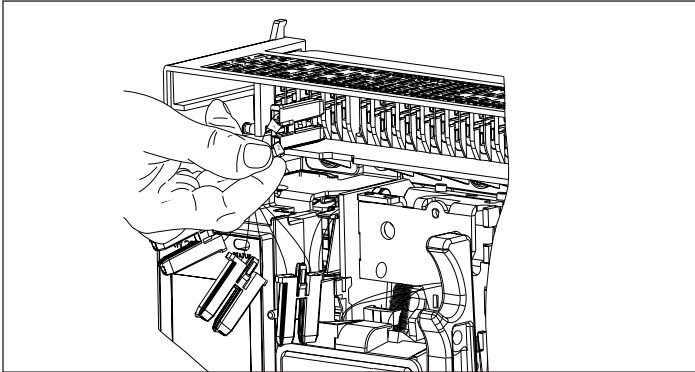

Figure 12. Secondary Plug Engaging Plug Housing.

Proceed with the following 12 steps.

Step 1: Become familiar with the drawout terminal block (Figure 1 of Section 1) and the terminal block mounting bracket.

Note: The terminal block mounting locations have numerical and descriptive laser-etched identifications (Figure 14).

Drawout terminal block brackets are supplied as part of the cassette and also have etched numerical identifications.

All of these identifications match the identifications on the breaker's secondary plug housing to ensure accurate terminal block placement.

In addition, a terminal block alignment bracket is assembled to provide proper alignment and separation of each individual terminal block during the levering (racking) process. Two alignment brackets are used with the RF Frame cassette since two cradles are required to accommodate the additional terminal blocks. The bracket's separation teeth ensure this alignment and separation (Figure 13). Terminal block alignment brackets must be removed to add or remove terminal blocks.

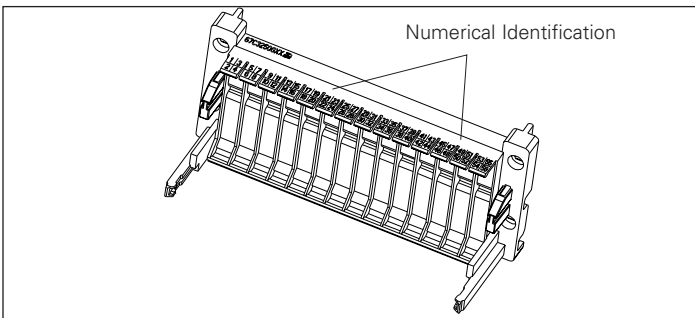

Figure 13. Step 1. Drawout Terminal Block Mounting Bracket.

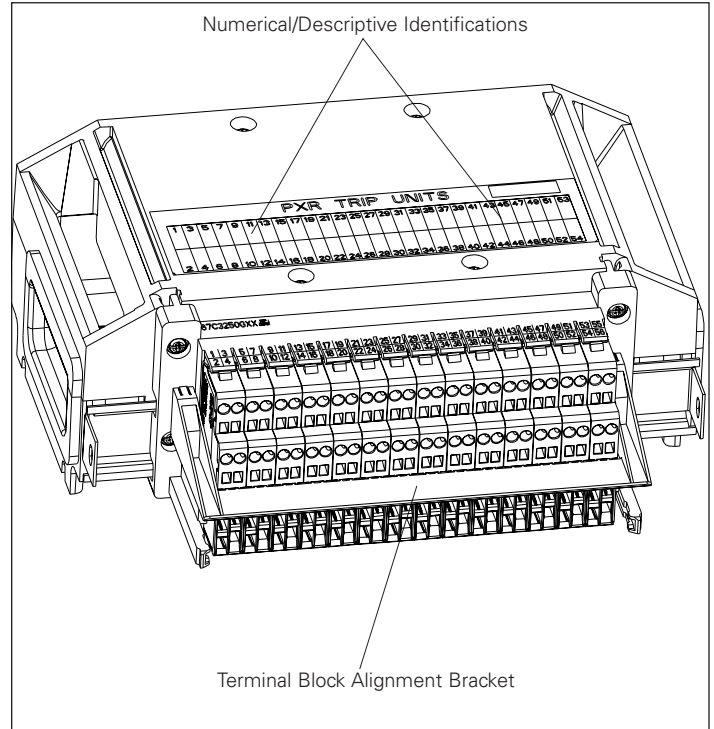

Figure 14. Step 1 (NF Frame).

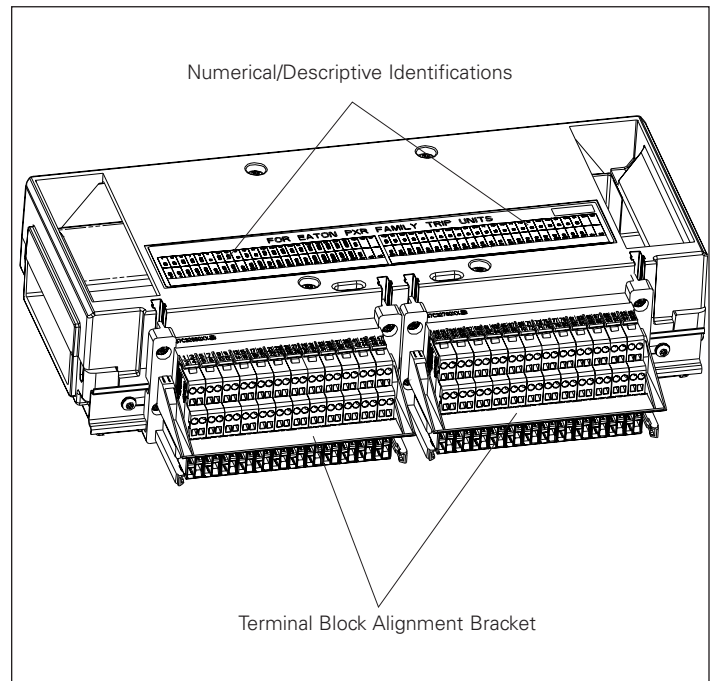

Figure 14a. Step 1 (RF Frame).

Step 2: To remove, grasp the terminal block alignment bracket on each side and gently pull away from the terminal blocks.

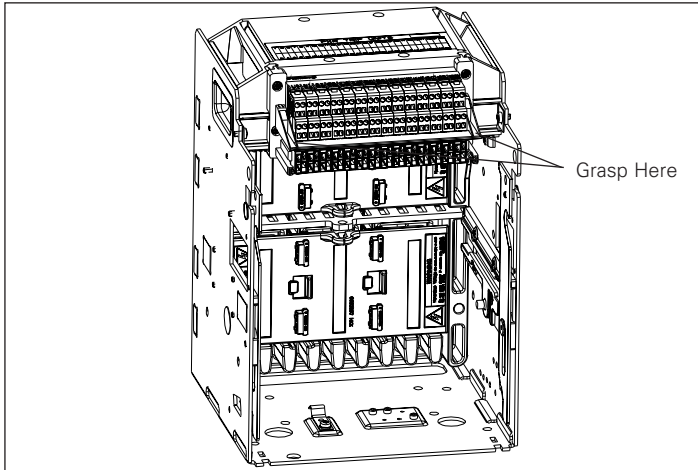

Figure 15. Step 2.

Step 3: Slide the alignment bracket out from between any mounted terminal blocks, and put it aside for re-installment after new terminal blocks are connected to the mounting bracket.

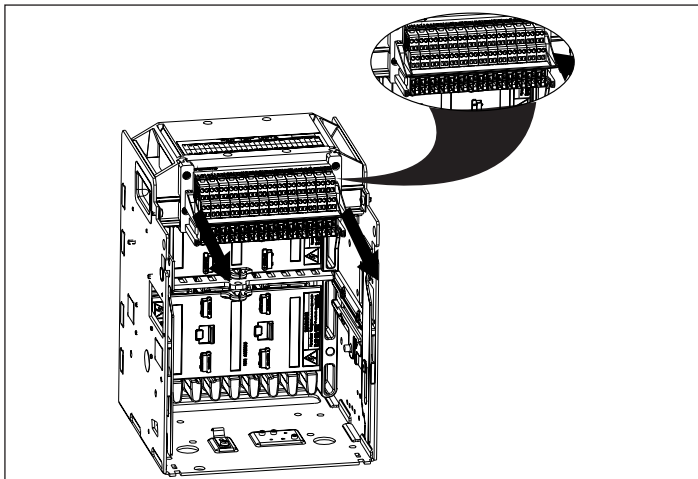

Figure 16. Step 3.

Step 4: Connect the bottom part of the terminal block to the lower part of the mounting bracket. Ensure the terminal block is positioned accurately.

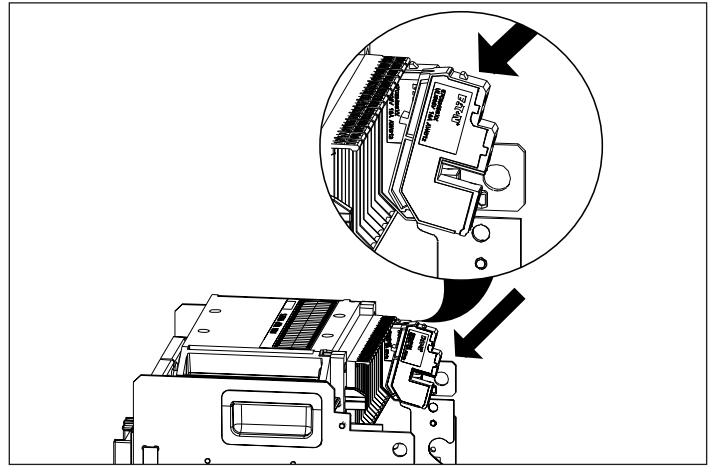

Figure 17. Step 4.

Step 5: Snap the top part of the terminal block onto the upper part of the mounting bracket. Ensure the terminal block is still positioned accurately and securely.

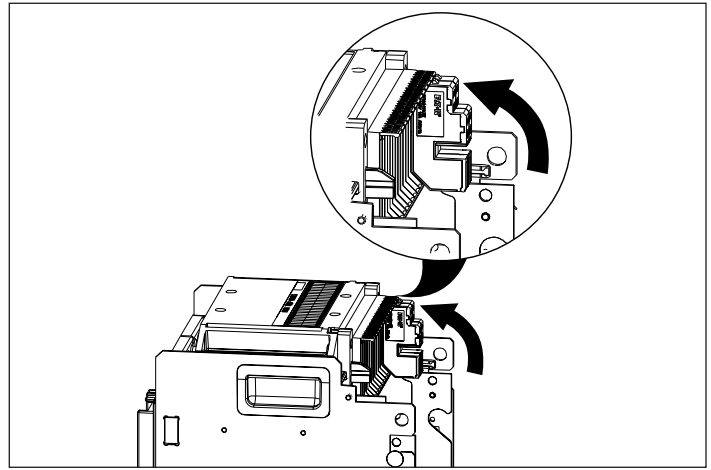

Figure 18. Step 5.

Step 6: Repeat Steps 4 and 5 until all terminal blocks are mounted, and check to ensure they are positioned in the correct locations. A small number terminal blocks would look as shown.

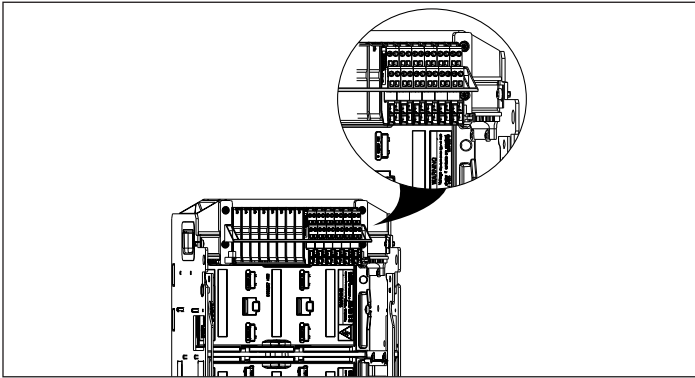

Figure 19. Step 6.

Step 7: Carefully put the terminal block alignment bracket back into position by sliding it back into the mounted terminal blocks.

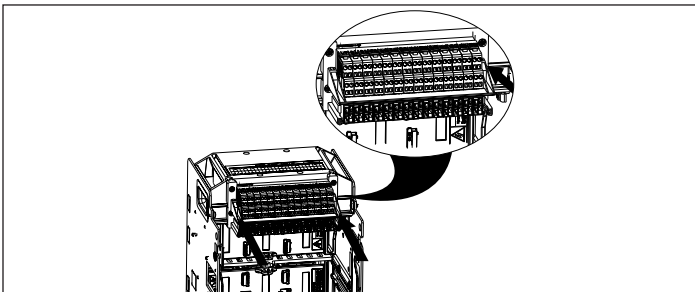

Figure 20. Step 7.

Step 8: Push the terminal block alignment bracket over the posts located on the terminal block mounting bracket. Ensure the alignment bracket is fully seated.

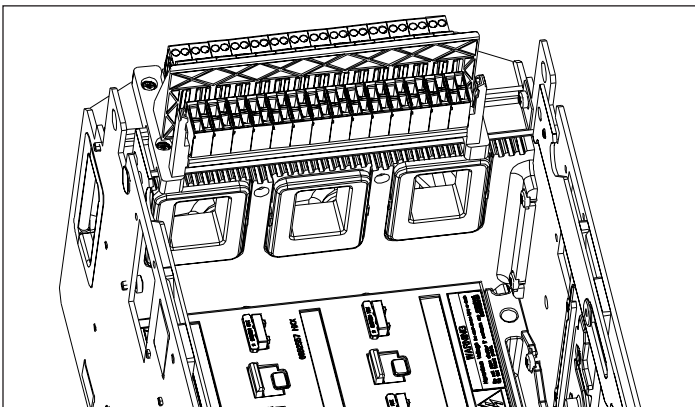

Figure 21. Step 8.

Step 9: Once the terminal block alignment bracket is in place, inspect it from the bottom to ensure that the teeth on the bracket separate each individual terminal block. Only one installed terminal block only should be visible between two teeth when the alignment bracket is properly positioned.

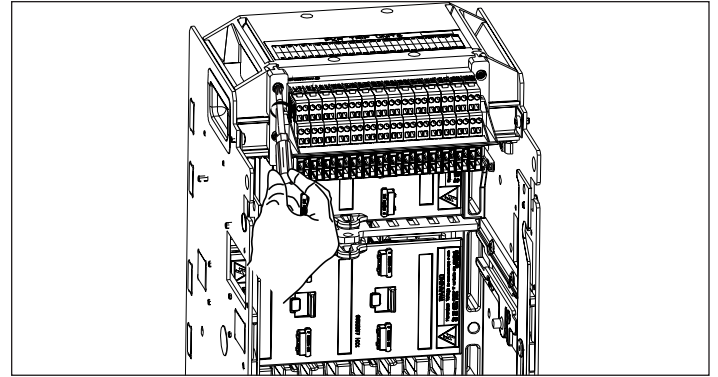
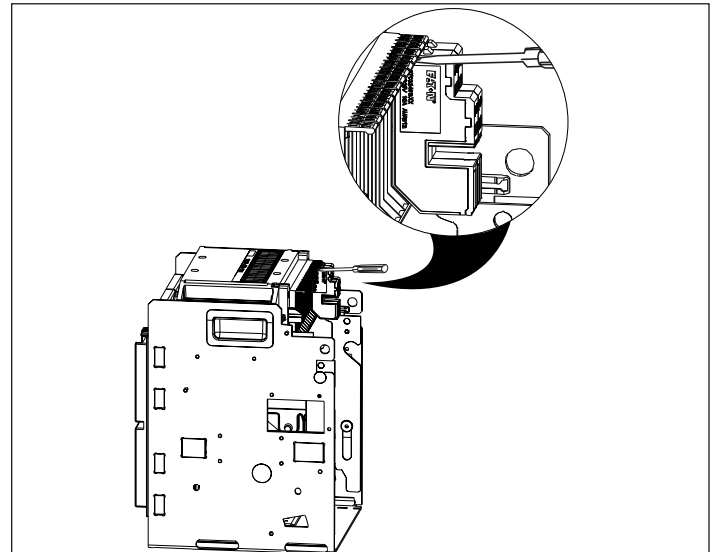

Figure 22. Step 9.

Step 10: To remove already mounted terminal blocks, first remove the terminal block alignment bracket by performing Steps 2 and 3 in this section.

Step 11: Remove any terminal block by inserting a small screwdriver under the mounting plate retainment tab at the top front of the terminal block as shown, and gently pry down to release and remove the block from the mounting bracket.



Step 12: After all terminal blocks to be removed are removed, perform Steps 7, 8, and 9 in this section to complete the removal process.

Disclaimer of Warranties and Limitation of Liability

The information, recommendations, descriptions, and safety notations in this document are based on Eaton's experience and judgment. This instructional literature is published solely for information purposes and should not be considered all-inclusive. If further information is required, you should consult an authorized Eaton sales representative.

The sale of the product shown in this literature is subject to the terms and conditions outlined in appropriate Eaton selling policies or other contractual agreement between the parties. This literature is not intended to and does not enlarge or add to any such contract. The sole source governing the rights and remedies of any purchaser of this equipment is the contract between the purchaser and Eaton.

NO WARRANTIES, EXPRESSED OR IMPLIED, INCLUDING WARRANTIES OF FITNESS FOR A PARTICULAR PURPOSE OR MERCHANTABILITY, OR WARRANTIES ARISING FROM COURSE OF DEALING OR USAGE OF TRADE, ARE MADE REGARDING THE INFORMATION, RECOMMENDATIONS, AND DESCRIPTIONS CONTAINED HEREIN.

In no event will Eaton be responsible to the purchaser or user in contract, in tort (including negligence), strict liability or otherwise for any special, indirect, incidental or consequential damage or loss whatsoever, including but not limited to damage or loss of use of equipment, plant or power system, cost of capital, loss of power, additional expenses in the use of existing power facilities, or claims against the purchaser or user by its customers resulting from the use of the information, recommendations and description contained herein.

The information contained in this manual is subject to change without notice.

Eaton
1000 Eaton Boulevard
Cleveland, OH 44122
United States
Eaton.com

© 2019 Eaton
All Rights Reserved
Printed in USA
Publication No. IL0131093EN / LNT29
Part No. IL0131093ENH03
January 2019