

# EcoStruxure™ EV Charging Expert

## User Guide

09/2022

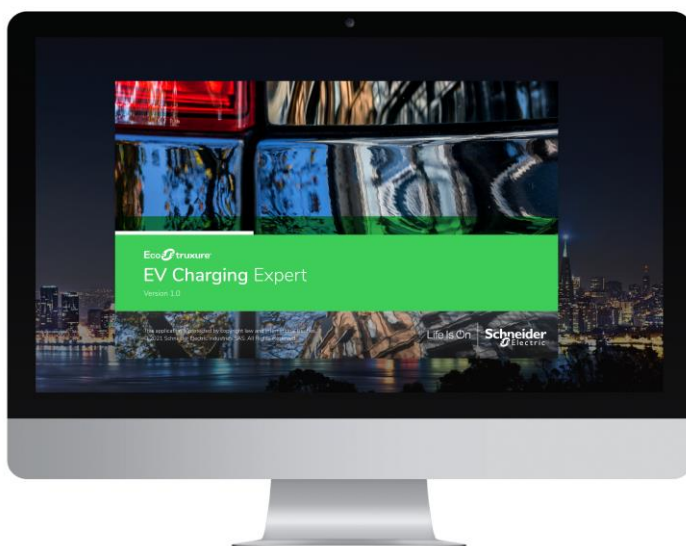
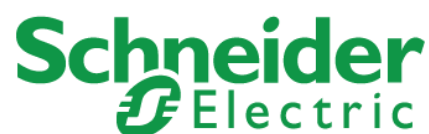

EcoStruxure EV Charging Expert is a **Solar Impulse Efficient Solution**.

Find out more here.

<https://solarimpulse.com/efficient-solutions/ecostruxure-ev-charging-expert>



## Legal information

The Schneider Electric brand and any registered trademarks of Schneider Electric Industries SAS referred to in this guide are the sole property of Schneider Electric SA and its subsidiaries. They may not be used for any purpose without the owner's permission, given in writing. This guide and its content are protected, within the meaning of the French intellectual property code (Code de la propriété intellectuelle français, referred to hereafter as "the Code"), under the laws of copyright covering texts, drawings and models, as well as by trademark law. You agree not to reproduce, other than for your own personal, noncommercial use as defined in the Code, all or part of this guide on any medium whatsoever without Schneider Electric's permission, given in writing. You also agree not to establish any hypertext links to this guide or its content. Schneider Electric does not grant any right or license for the personal and noncommercial use of the guide or its content, except for a non-exclusive license to consult it on an "as is" basis, at your own risk. All other rights are reserved.

Electrical equipment should be installed, operated, serviced and maintained only by qualified personnel. No responsibility is assumed by Schneider Electric for any consequences arising out of the use of this material.

As standards, specifications and designs change from time to time, please ask for confirmation of the information given in this publication.

# About this guide

## Document scope

The purpose of this guide is to provide installers, maintenance personnel and users with the technical information necessary to install, commission and use the EcoStruxure EV Charging Expert.

### Introduction

- EcoStruxure EV Charging Expert main features:
  - allocate a current setpoint to the charging stations in operation
  - see in real time the status of the charging stations through the dashboard
  - manage user authentication for charging authorization
  - get the charging sessions history and data from the charging stations in the network
- EcoStruxure EV Charging Expert is compatible with remote supervision from a Charge Point Operator in OCPP 1.6 Json.
- EcoStruxure EV Charging Expert allows two access profiles:

**Admin:** Access to all configuration parameters and features, dashboard operation and RFID cards management.

**User:** Dashboard operation and RFID cards management.

### Related documents

Title of documentation	Reference number
EVlink Parking - EVlink Smart Wallbox - EVlink City - Charging station Commissioning Guide (English)	DOCA0060EN
EVlink Parking - EVlink City - EVlink Smart Wallbox - Charging Stations - Troubleshooting Guide (English)	DOCA0117EN
Instructions sheet - EVP2MM - Modem (English, French)	QGH5298301
Instructions sheet for Acti9 Smartlink SI D gateway A9XMWA20 (English, Dutch, French, German, Italian, Portuguese, Spanish, Chinese, Russian)	NVE60007
Instructions sheet for power meter METSEPM5320 (English, Dutch, French, German, Italian, Portuguese, Spanish, Chinese, Russian)	HRB69887
Instructions sheet for power meter A9MEM3250 (English, Dutch, French, German, Italian, Portuguese, Spanish, Chinese, Russian)	NHA15795
Instructions sheet for Enerlin'X IFE gateway LV434002 (English, French)	DOCA0084
Instructions sheet Enerlin'X EIFE communication module LV851001 (English, French)	DOCA0106
Installation guide for EcoStruxure EV Charging Expert (English)	DOCA0164EN

You can download these technical publications and other technical information from our website at <https://www.se/en/download>

# Safety information

## Important information

Read these instructions carefully and look at the equipment to become familiar with the device before trying to install, operate, service, or maintain it. The following special messages may appear throughout this manual or on the equipment to warn of potential hazards or to call attention to information that clarifies or simplifies a procedure.



The addition of either symbol to a “Danger” or “Warning” safety label indicates that an electrical hazard exists which will result in personal injury if the instructions are not followed.



This is the safety alert symbol. It is used to alert you to potential personal injury hazards. Obey all safety messages that follow this symbol to avoid possible injury or death.

### **DANGER**

**DANGER** indicates a hazardous situation which, if not avoided, **will result in** death or serious injury.

### **WARNING**

**WARNING** indicates a hazardous situation which, if not avoided, **could result in** death or serious injury.

### **CAUTION**

**CAUTION** indicates a hazardous situation which, if not avoided, **could result in** minor or moderate injury.

### **NOTICE**

**NOTICE** is used to address practices not related to physical injury.

## PLEASE NOTE

Electrical equipment should be installed, operated, serviced, and maintained only by qualified personnel. No responsibility is assumed by Schneider Electric for any consequences arising out of the use of this material.

A qualified person is one who has skills and knowledge related to the construction and operation of electrical equipment and its installation and has received safety training to recognize and avoid the hazards involved.

# Table of contents

<b>Chapter 1. SYSTEM ENVIRONMENT .....</b>	<b>9</b>
1.1 EcoStruxure EV Charging Expert.....	10
1.1.1 Overview .....	10
1.1.2 EcoStruxure EV Charging Expert communication devices .....	15
1.1.3 EcoStruxure EV Charging Expert network architecture .....	18
1.2 EcoStruxure EV Charging Expert characteristics .....	19
1.2.1 General characteristics .....	19
1.2.2 Environmental characteristics.....	19
1.2.3 Power supply characteristics .....	19
1.2.4 Communication modules .....	20
1.3 Set up of EcoStruxure EV Charging Expert system environment.....	21
1.3.1 EcoStruxure EV Charging Expert installation .....	21
1.4 Zone definition.....	23
1.5 Commissioning of remote connection to EcoStruxure EV Charging Expert	26
1.5.1 Initial condition .....	26
1.5.2 Example of selection of the modem port: .....	26
1.5.3 Commissioning of the EVlink modem (EVP3MM) .....	27
<b>Chapter 2. EcoStruxure EV Charging Expert COMMISSIONING .....</b>	<b>31</b>
2.1 Getting started with EcoStruxure EV Charging Expert .....	32
2.1.1 Computer configuration .....	32
2.1.2 Login to the EcoStruxure EV Charging Expert (Wizard) .....	32
2.2 EcoStruxure EV Charging Expert commissioning.....	35
2.2.1 Firmware update.....	35
2.2.2 Administration and User password configuration .....	36
2.2.3 Log in the EcoStruxure EV Charging Expert .....	37
2.3 Network configuration .....	38
2.3.1 EcoStruxure EV Charging Expert name .....	38
2.3.2 Ethernet configuration.....	38
2.3.3 DHCP server configuration.....	39
2.4 Charging stations commissioning .....	40
2.4.1 Prerequisites .....	40
2.4.2 Charging station landing page .....	40
2.4.3 Description.....	40
2.4.4 Filter Charging Stations .....	40
2.4.5 Charging station configuration.....	41
2.4.6 Get the serialNumber of a charging station .....	43
2.5 Power meter configuration .....	45
2.5.1 Prerequisites .....	45
2.5.2 Power meter landing page.....	45
2.5.3 Power meter setting.....	46
2.5.4 Power meter models.....	47
2.6 Zone configuration.....	50
2.6.1 Prerequisites .....	50
2.6.2 Zone configuration .....	50
2.6.3 Zone creation.....	51
2.6.4 Degraded Mode .....	51
2.6.5 Zone settings .....	53

2.7	Charging stations assignment to zone .....	54
2.8	Remote supervision configuration .....	55
2.8.1	Remote supervision configuration .....	55
2.9	Load shedding strategy and degraded mode .....	57
2.9.1	Definition .....	57
2.9.2	Prerequisites .....	57
2.9.3	Degraded mode configuration page .....	57
2.10	Authentication mode configuration .....	59
2.11	RFID card management .....	60
2.11.1	Prerequisites .....	60
2.11.2	RFID card management configuration page .....	60
2.11.3	RFID card addition .....	60
2.11.4	RFID card file export .....	61
2.11.5	RFID card removal .....	61
2.11.6	RFID card update .....	61
2.11.7	Bulk modification .....	62
2.11.8	RFID cards filters .....	62
<b>Chapter 3. OPERATION INTERFACE .....</b>		<b>63</b>
3.1	Login to the EcoStruxure EV Charging Expert (Webserver) .....	64
3.2	Menu and status bar .....	64
3.2.1	Bar items .....	64
3.3	Dashboard .....	65
3.3.1	Global view .....	65
3.3.2	Zone view .....	67
3.3.3	Charging station view .....	69
3.3.4	Charging station view – EVlink Pro AC firmware update .....	69
3.4	RFID card management .....	70
3.4.1	Prerequisites .....	70
3.4.2	RFID card management configuration page .....	70
3.4.3	RFID card addition .....	70
3.4.4	RFID card file export .....	71
3.4.5	RFID card removal .....	71
3.4.6	RFID card update .....	72
3.4.7	Bulk Modification .....	72
3.5	Network configuration .....	73
3.5.1	Ethernet configuration .....	73
3.5.2	Proxy configuration .....	73
3.5.3	DHCP server configuration .....	73
3.6	Remote supervision configuration .....	74
3.6.1	Remote supervision configuration .....	74
3.7	Zone configuration .....	76
3.7.1	Prerequisites .....	76
3.7.2	Zone landing page .....	76
3.7.3	Description .....	77
3.7.4	Degraded mode .....	77
3.7.5	Zone settings .....	77
3.7.6	Authentication mode by zone .....	78
3.8	Power meter configuration .....	79
3.9	Time-of-use (TOU) .....	79
3.9.1	Definition .....	79
3.9.2	Prerequisites .....	79
3.9.3	Tariff period configuration tab .....	79

3.9.4	Zone configuration tab .....	82
3.9.5	Summary tab .....	82
3.9.6	Disable TOU feature .....	83
3.10	Energy Management through Digital inputs .....	84
3.10.1	Definition .....	84
3.10.2	Prerequisites .....	84
3.10.3	Commissioning .....	84
3.10.4	Electrical connection .....	86
3.10.5	Maximum setpoint management .....	86
3.11	Advanced configuration .....	87
3.11.1	Definition .....	87
3.11.1	Cybersecurity .....	87
3.11.2	Power meter .....	88
3.11.3	Webservice configuration .....	88
3.11.4	Miscellaneous .....	88
3.12	User management .....	89
3.12.1	User management landing page .....	89
3.12.2	Add a user .....	89
3.12.3	Change the user password .....	90
3.12.4	Delete a user .....	90
3.13	Charging station commissioning .....	91
3.13.1	Prerequisites .....	91
3.13.2	Charging station landing page .....	91
3.13.3	Description .....	91
3.13.4	Update charging station discovery .....	91
3.13.5	Definition of authentication mode .....	92
3.13.6	Filter your charging stations .....	93
3.14	Load shedding strategy and degraded mode .....	94
3.14.1	Definition .....	94
3.14.2	Prerequisites .....	94
3.14.3	Degraded mode configuration page .....	94
3.15	Maintenance .....	96
3.15.1	Read EcoStruxure EV Charging Expert Logs .....	96
3.15.2	Download the maintenance report .....	96
3.15.3	Download the Charging Stations maintenance report Logs .....	97
3.16	EcoStruxure EV Charging Expert firmware update .....	98
3.17	EcoStruxure EV Charging Expert License upgrade .....	99
3.17.1	Get your EcoStruxure EV Charging Expert unique Identifier .....	99
3.17.2	Import the EcoStruxure EV Charging Expert upgrade package .....	99
3.18	Reboot and back to factory settings .....	100
3.18.1	Reboot and back to factory settings from the webserver .....	100
3.18.2	Hardware back to factory settings .....	100
3.19	Save and Restore .....	101
3.19.1	Save the EcoStruxure EV Charging Expert configuration .....	101
3.19.2	Restore during system commissioning .....	101
3.19.3	Restore during system operation .....	102
<b>Chapter 4. EcoStruxure EV Charging Expert Maintenance .....</b>		<b>103</b>
4.1	Hardware back to factory settings .....	104
4.1.1	Definition .....	104
4.1.2	Prerequisites .....	104
4.1.3	Hardware back to Factory Settings procedure .....	104
4.2	Regular cleaning and maintenance .....	105

---

4.2.1	Introduction .....	105
4.2.2	Cleaning solutions.....	105



---

Chapter 1.

# SYSTEM ENVIRONMENT

# 1.1 EcoStruxure EV Charging Expert

## 1.1.1 Overview

### 1.1.1.1 Power management functions

The power available for the charging stations will be distributed among the vehicles that are charging.

An electric vehicle needs a minimum setpoint to accept charging and, if this minimum is not available, the charge will momentarily be suspended.

The Load Management System allows the Admin profile to choose between two thresholds (floor values):

- 8A by default for single phase charging and 14A by default for three-phase charging (based on EV/ZE ready)
- 6A by default for both single phase and three-phase (based on IEC 61851)

When a new vehicle connects and there is not enough available power, the system will suspend the charging of another vehicle to allow the new vehicle to charge.

Two options of charging prioritization are available during the configuration of the load management system:

- Energy:

The system suspends the charging of vehicles which have already consumed the highest amount of energy.

This option is set by default.

- Duration:

The system suspends the charging of vehicles with the longest charging time.

In both options, the EcoStruxure EV Charging Expert checks the values every 15 minutes and updates charging rights accordingly

Only the Admin profile can change this parameter.

According to the EcoStruxure EV Charging Expert reference (only available for commercial references HMIBSCEA53D1ESM, -EDM, -EDL, -EML), the EcoStruxure EV Charging Expert can manage:

- VIP RFID cards, that make it possible for the user to get the maximum available\* power at any time no matter the charging station.
- VIP charging stations, that make it possible for any user RFID card to get the maximum available\* power at any time on that specific VIP charging station.

The VIP status (RFID card or charging station) can be added or deleted with the Admin or User profiles.

*\*The maximum available power for VIP status may be lower than the charging station rating depending on the number of VIP charging at the same time.*

### 1.1.1.2 Power management: two possible implementations

#### Static mode

The maximum current setpoint for the whole charging infrastructure is a fixed value depending on the subscribed power supply and on the consumed power in the rest of the building. This current is distributed between all connected vehicles to limit the risk of installation tripping.

##### Consumption profile in static mode:

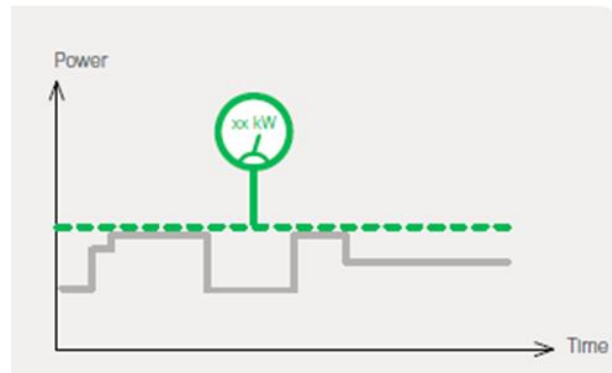

For example, ten 22kVA charging points can be used at the same time with a total consumption not exceeding 100kVA.

#### Dynamic mode

The maximum current setpoint for the whole charging infrastructure dynamically changes according to the building consumption while considering the subscribed power supply. The remaining available current is distributed between all connected vehicles to limit the risk of installation tripping.

##### Consumption profile in dynamic mode:

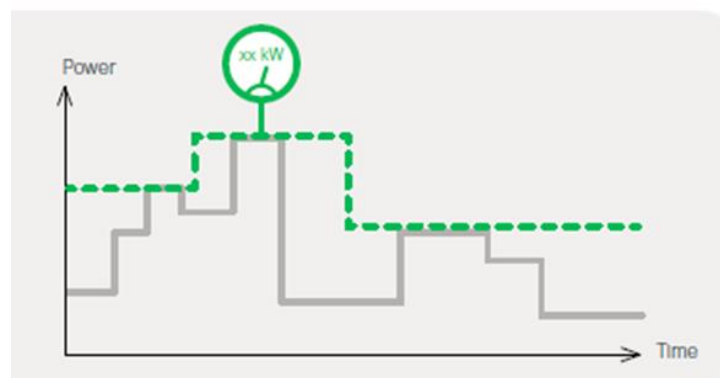

For example, ten 22kVA charging points can be used at the same time within an installation designed to provide 150kVA for both the building and all the charging stations. Depending on the building consumption, the maximum current setpoint for the whole charging infrastructure can theoretically reach 150kVA.

**In dynamic mode, the EcoStruxure EV Charging Expert must be connected to power meters measuring the consumption of the building and the charging stations.**

### 1.1.1.3 EcoStruxure EV Charging Expert product range & features

		EV Charging Expert with Static mode (dynamic load management with STATIC current setpoint)		EV Charging Expert with Dynamic & Static modes (dynamic load management with DYNAMIC current setpoint, or STATIC current setpoint)			
References (2)		HMIBSCEA53D1ESS	HMIBSCEA53D1ESM	HMIBSCEA53D1EDB	HMIBSCEA53D1EDS	HMIBSCEA53D1EDM	HMIBSCEA53D1EDL
<b>Features</b>							
Capacity	Number of EVlink charging stations	15	50	5	15	50	100
Power management	Dynamic, with a STATIC current setpoint	●	●	●	●	●	●
	Dynamic, with a DYNAMIC current setpoint			●	●	●	●
	Time of use		●		●	●	●
Multi zone	Maximum number of zones	1	10	2	2	10	20
	Maximum number of zones levels	1	3	2	2	3	3
Other loads	Power consumption reporting on other feeders		●			●	●
Badge management	VIP privilege user badge		●			●	●
Stations management	VIP privilege charging station		●			●	●

- (1)
- (2) To upgrade from a current commercial reference to an upper-level one, please consult us

Note: The maximum number of zones includes zones and sub-zones (refer to [chapter 2.6 Zones configuration](#)).

Contact your Schneider Electric sales representative if you wish to upgrade from your current EcoStruxure EV Charging Expert software license (commercial reference) to a higher version. See §3.17- EcoStruxure EV Charging Expert License upgrade for more details.

### 1.1.1.4 User profile features

#### Operate EcoStruxure EV Charging Expert Dashboard

At a glance the user can:

- See the status of all charging stations or some of them
- Track the power consumption per phase

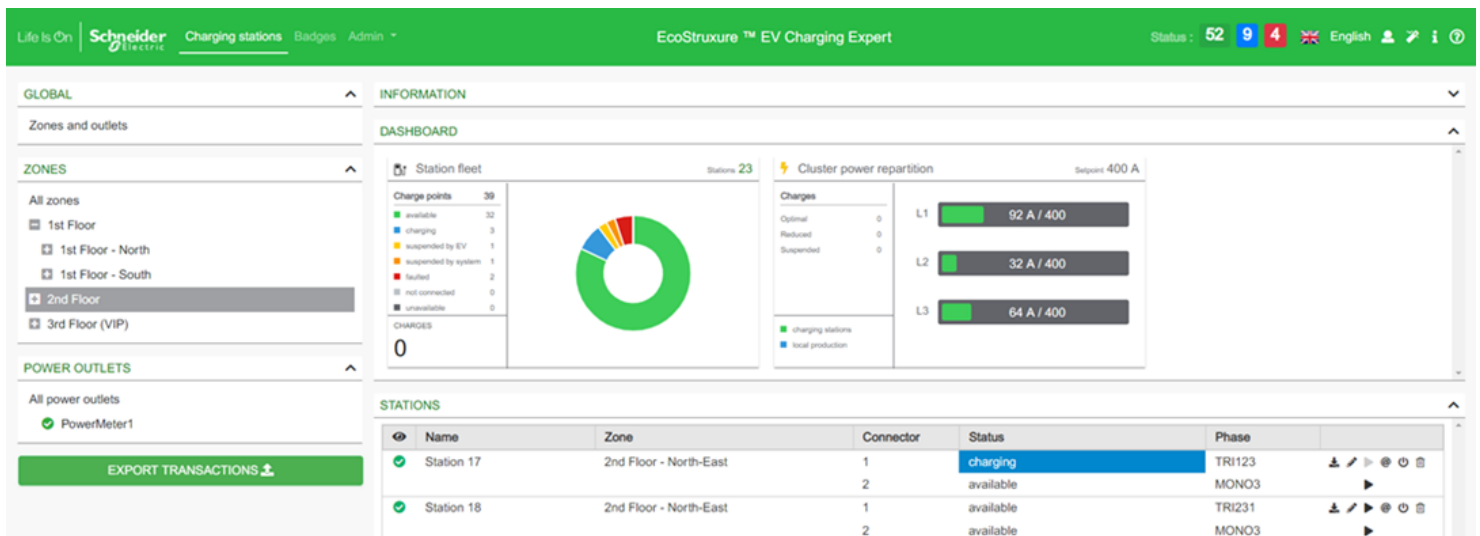

#### Remote control of charging station and transactions

Remote start, remote stop, remote force stop, reboot (automatic charging resume), reset (charging stopped), access to maintenance report  
*Access through "Station" tab.*

#### **Add, remove RFID cards in a list**

When the EcoStruxure EV Charging Expert is set as the authentication mode, the following features are available: add, remove, update RFID cards and modify credentials (ex: VIP RFID cards).

*Access through "RFID cards" page from the dashboard.*

#### **Export Charging Data Records (CDR)**

On the EcoStruxure EV Charging Expert Dashboard, the user can see the ongoing charging sessions or all the sessions since the commissioning of the EcoStruxure EV Charging Expert.

EcoStruxure EV Charging Expert can register over 1 million transactions data, also called charging data records, in its internal memory. The charging data records can also be exported to an external file in CSV format for all the charging stations.

It is possible to select the period before exporting the file.

*Access through "Export transaction" from the dashboard.*

#### **1.1.1.5 Admin profile features**

In addition to the user profile features, the Admin profile can change the configuration of the charging stations, and upgrade EcoStruxure EV Charging Expert firmware.

#### **EcoStruxure EV Charging Expert commissioning**

All the parameters are accessible via the Admin page.

The Admin profile sets configuration parameters for:

- Network configuration
- Remote supervision
- Zone operating mode (static or dynamic)
- Current limitation per zone
- Charging stations
- Load-shedding strategy and degraded mode (communication lost)
- Time of use
- Digital inputs

#### **EcoStruxure EV Charging Expert maintenance**

The Admin profile can:

- Update the EcoStruxure EV Charging Expert firmware
- Operate a "Back to factory"
- Operate a "Save & restore"
- Manage users accounts and passwords
- Download EcoStruxure EV Charging Expert maintenance report
- Access the Wizard that is used for initial commissioning

1.1.1.6 EcoStruxure EV Charging Expert hardware features

**⚠ CAUTION**

**RISK OF BURNS**

Do not touch the surface of the heat sink during operation.

During operation, the surface temperature of the heat sink may exceed 70 °C.

**Failure to follow these instructions could result in minor or moderate injury**

**Description**

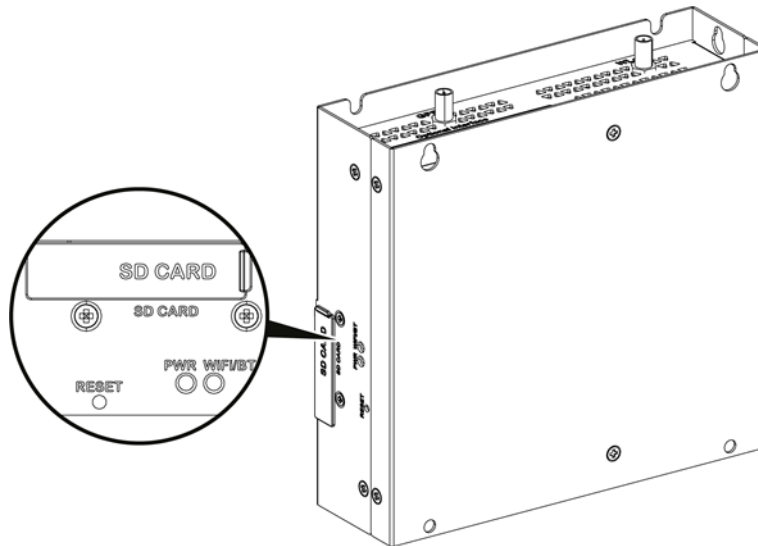

Reset button and LEDs

The table below describes the meaning of the status LEDs

Marking	Color	State	Meaning
PWR	Green	On	Active (user operates OS) (state S0)
WiFi/BT	Green	Off	No WiFi/BT data transmission
		On	Data transmission

**Front view**

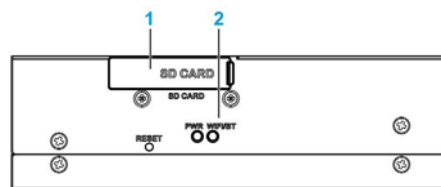

- 1 - SD card socket (SD card not delivered with the EcoStruxure EV Charging Expert)
- 2- LEDs and reset button

## Front view

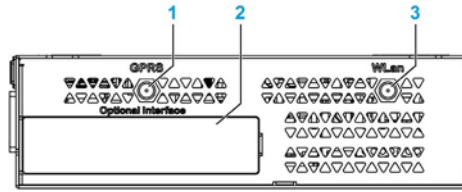

- 1 - SMA connector for the GPRS/4G external antenna (function not yet available)
- 2 - Optional interface
- 3 - SMA connector for the WLAN external antenna (function not yet available)

## Rear view

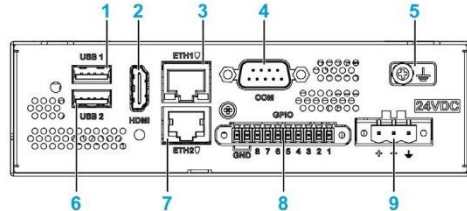

- 1 - USB1 (USB 2.0)
- 2 - HDMI port
- 3 - ETH1 (10/100/1000 Mb/s)
- 4 - COM port RS-232/422/485
- 5 - Ground connection pin
- 6 - USB2 (USB 2.0)
- 7 - ETH2 (10/100/1000 Mb/s)
- 8 - GPIO
- 9 - DC power connector

## 1.1.2 EcoStruxure EV Charging Expert communication devices

### 1.1.2.1 EVlink charging stations

#### EVLINK CHARGING STATIONS COMPATIBILITY

SMART  
WALLBOX

PARKING

CITY

EVLINK PRO AC

DC FAST  
CHARGE

For AC charging stations (SMART WALLBOX, PARKING and CITY), the EcoStruxure EV Charging Expert is compatible with the **v3.2.0.0.12** firmware release or higher. See DOCA0060 “EVlink Charging Stations commissioning guide” to learn how to check the firmware release of the charging stations and update it.

For AC charging stations (EVlink Pro AC and EVlink Pro AC Metal), the EcoStruxure EV Charging Expert is compatible with the v01.00.00 firmware release or higher.

For DC FAST CHARGE 24 kW stations, the EcoStruxure EV Charging Expert is compatible with mono and bi-connector stations on **v22PRO017362 V013** firmware release or higher. Please contact your local Schneider Electric representative if you want to configure a DC FAST CHARGE station.





Latest releases are available on [se.com/download](https://se.com/download).

For previous releases, contact Schneider Electric Customer Care Center.

### 1.1.2.2 Power meters

Note: power metering is only required when the EcoStruxure EV Charging Expert is used in dynamic mode.

The table below lists the power meters compatible with the EcoStruxure EV Charging Expert.

Name	Pole description	Input type	Connection to EcoStruxure EV Charging Expert
A9MEM3250 (Link 150 + Acti 9 iEM3000) 	1P + N / 3P / 3P + N	External CT: 1 A or 5 A  CT: Current Transformer	See §2.5 Power meter connection
METSEPM5320 (PowerLogic PM5000) 	1P + N / 3P / 3P + N		On the same network where the EcoStruxure EV Charging Expert is connected
A9XMWD20 (PowerTag Link + Power Tags) 	1P + N / 3P / 3P + N	Wireless energy sensor PowerTag up to 630 A	On the same network where the EcoStruxure EV Charging Expert is connected
Compact NSX circuit breaker with embedded metering (with Enerlin'X IFE gateway) 	3P / 4P	Modbus TCP	On the same network where the EcoStruxure EV Charging Expert is connected
Masterpact MTZ circuit breaker with embedded metering (with embedded Enerlin'X EIFE module) 	3P / 4P	Modbus TCP	On the same network where the EcoStruxure EV Charging Expert is connected



### 1.1.2.2.1 Modbus registers tables

The following tables show the ModBus registers per type of power meter.

Power meter model	“PM5320, IEM3x5x, Power tag A”
Register @	Description
3000	Intensity Ph1
3002	Intensity Ph2
3004	Intensity Ph3
3060	power Total Active
3204	energyDeliveredActive

Power meter model	“NSX legacy”
Register @	Description
12016	Intensity Ph1
12017	Intensity Ph2
12018	Intensity Ph3
12041	power Total Active
12050	energyDeliveredActive

Power meter model	“NSX”
Register @	Description
1016	Intensity Ph1
1017	Intensity Ph2
1018	Intensity Ph3
1037	power Total Active
2000	energyDeliveredActive

Power meter model	“MTZ”
Register @	Description
32028	Intensity Ph1
32030	Intensity Ph2
32032	Intensity Ph3
32078	power Total Active
32096	energyDeliveredActive

Other power meters than those listed on the table on chapter 1.1.2.2 are compatible with EcoStruxure EV Charging Expert as well, as long as they match one of the four lists of ModBus registers detailed here above. When commissioning the power meter, select from the drop-down list on “Model” field the corresponding model of power meter matching the appropriate registers list.

See [chapter 2.5 Power Meters commissioning](#) for more information.

### 1.1.2.3 Modem

Name	Description	Connection to EcoStruxure EV Charging Expert
EVP3MM 	3G/4G	On the same network where the EcoStruxure EV Charging Expert is connected

Note: Other modems could be used (router function is required).

## 1.1.3 EcoStruxure EV Charging Expert network architecture

### 1.1.3.1 Star topology

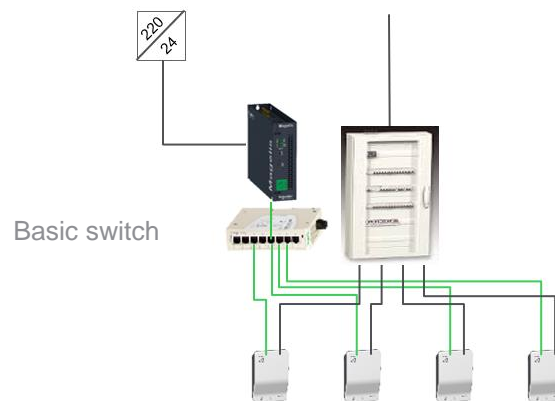

### 1.1.3.2 Ring topology

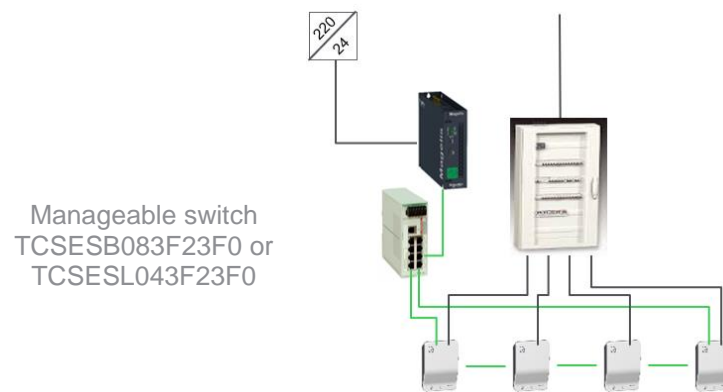

### 1.1.3.3 Daisy chain topology

— Ethernet network  
— Power supply

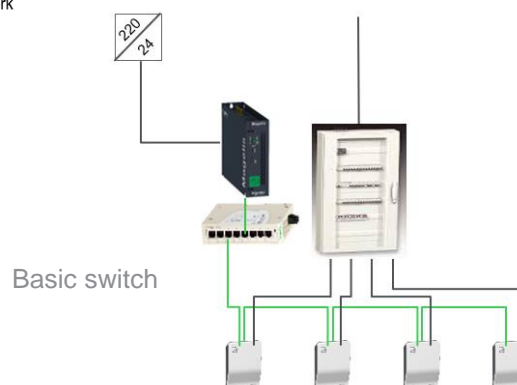

This topology is not recommended as it does not ensure optimum continuity of service

## 1.2 EcoStruxure EV Charging Expert characteristics

### 1.2.1 General characteristics

Element	Characteristics
Operating System	Linux Yocto
Cooling method	Natural air flow
Weight	1 kg (2.2 lbs)

#### 1.2.1.1 Dimensions

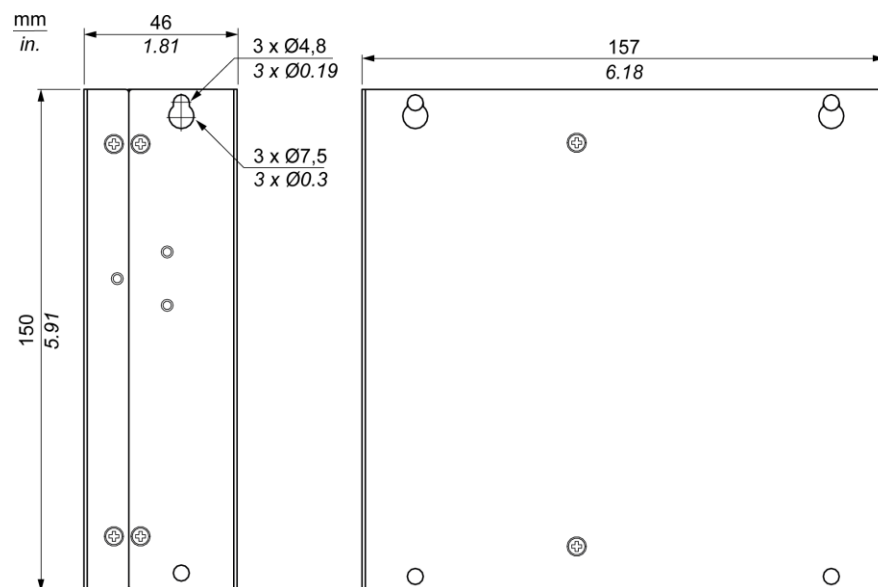

### 1.2.2 Environmental characteristics

Characteristics	Value
Degree of protection	IP 40
Pollution degree	For use in pollution degree 2 environment
Operating temperature	0...50 °C
Operating temperature for horizontal mounting	0...50 °C
Storage temperature	0...50 °C
Operating altitude	2,000 m (6,560 ft) max
Random vibration	5...500 Hz: 2 G <sub>rms</sub>
Storage humidity	10...95 % RH at 40 °C (104 °F), no condensation

### 1.2.3 Power supply characteristics

Element	Characteristics
Rated voltage	24 Vdc
Inrush current	1,5 A
Power consumption	16 W

## 1.2.4 Communication modules

### 1.2.4.1 USB interface

Element	Characteristics
Type	USB 2.0
Current load	Maximum 0.5 A
Connection	Type A

### 1.2.4.2 Ethernet interface

Element	Characteristics
Type	RJ45
Speed	10/100/1000 Mb/s base-T

# 1.3 Set up of EcoStruxure EV Charging Expert system environment

## 1.3.1 EcoStruxure EV Charging Expert installation

See DOCA0164EN-02 “EcoStruxure EV Charging Expert installation guide” available on the EcoStruxure EV Charging Expert packaging and on [se.com/download](http://se.com/download)

### 1.3.1.1 Ethernet connection: charging station connection

EcoStruxure EV Charging Expert is connected to the charging station network through Ethernet connector ETH1 (**do not use ETH2**).

Use an Ethernet straight cable between EcoStruxure EV Charging Expert and the charging station Ethernet network.

### 1.3.1.2 Power meter connection

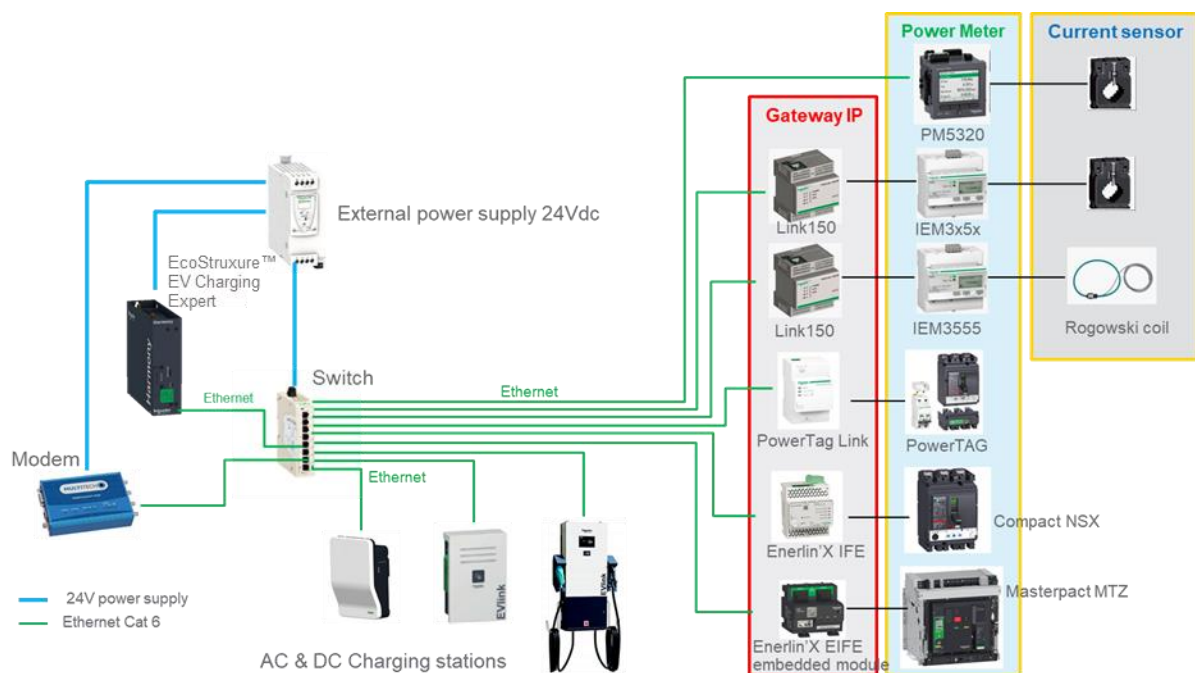

Gateways and power meters must be set correctly before starting the EcoStruxure EV Charging Expert commissioning. Please check the relevant documentation to perform this step.

Note: power metering is only required when the EcoStruxure EV Charging Expert is used in dynamic load management mode.

**Link:** commercial reference EGX150

**User Guide document reference available on se.com :**

- EN → DOCA0110EN
- FR → DOCA0110FR

**Acti9 PowerTag Link (Acti 9 Smartlink):** commercial reference A9XMWD20 or A9XMWD100

**User Guide document reference available on se.com :**

- EN → DOCA0157EN
- FR → DOCA0157FR

**PM5320:** commercial reference METSEPM5320

**User Guide document reference available on se.com :**

- EN → EAV15107-EN
- FR → EAV15107-FR

**Acti 9 IEM3X5X:** commercial reference A9MEM3X5X**User Guide document reference available on se.com :**

- EN → DOCA0005EN
- FR → DOCA0005FR

**PowerTag A9MEM15XX****User Guide document reference available on se.com :**

- EN → DOCA0157EN
- FR → DOCA0157FR

**PowerTag A9MEM15XX & Acti 9 IEM3X5X:** refer to Schneider Electric catalog to select the right reference

**Enerlin'X IFE LV434002:****User Guide document reference available on se.com :**

- EN → DOCA0084EN
- FR → DOCA0084FR

**Enerlin'X EIFE LV851001:****User Guide document reference available on se.com :**

- EN → DOCA0106EN
- FR → DOCA0106FR

## 1.4 Zone definition

A zone is made of one switchboard:

- directly supplying charging stations and possibly other electrical loads,
- or supplying other switchboards of which at least one is supplying charging stations and possibly other electrical loads. This latter forms a sub-zone. The total installed power of all sub-zones must be at least equal to the maximum power that can be delivered by the upper zone switchboard. Three levels of sub-zones are possible.

The maximum number of zones and sub-zones depends on the EcoStruxure EV Charging Expert reference (see features table on [chapter 1.1.1.3](#)).

### Example #1: one single zone

In this example, the main switchboard can supply both switchboards at the maximum power. Energy management is required in the zone if the switchboard #1 cannot supply all charging stations and other electrical loads at the same time at the maximum power.

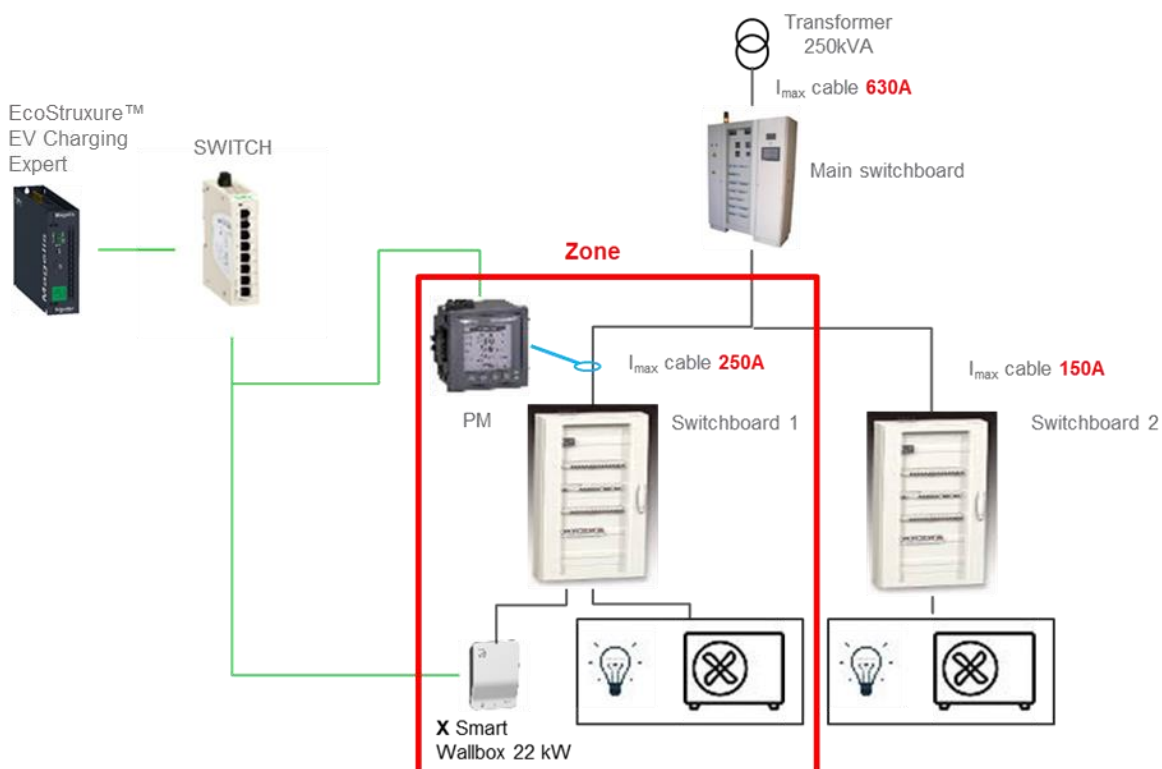

### Example #2: one zone with one sub-zone

In this example, the main switchboard cannot supply both switchboards at the maximum power. In the same way, the switchboard 1 cannot supply all charging stations and other electrical loads at the same time at the maximum power.

The power available to charging stations will depend on:

- the total consumption of other electrical loads supplied by switchboards 1 and 2 due to the current limitation of the main switchboard (630 A),
- on the consumption of other electrical loads supplied by switchboard 1 due to its current limitation (400 A)

As a result, it is necessary to define a zone (main switchboard) with a sub-zone (switchboard 1).

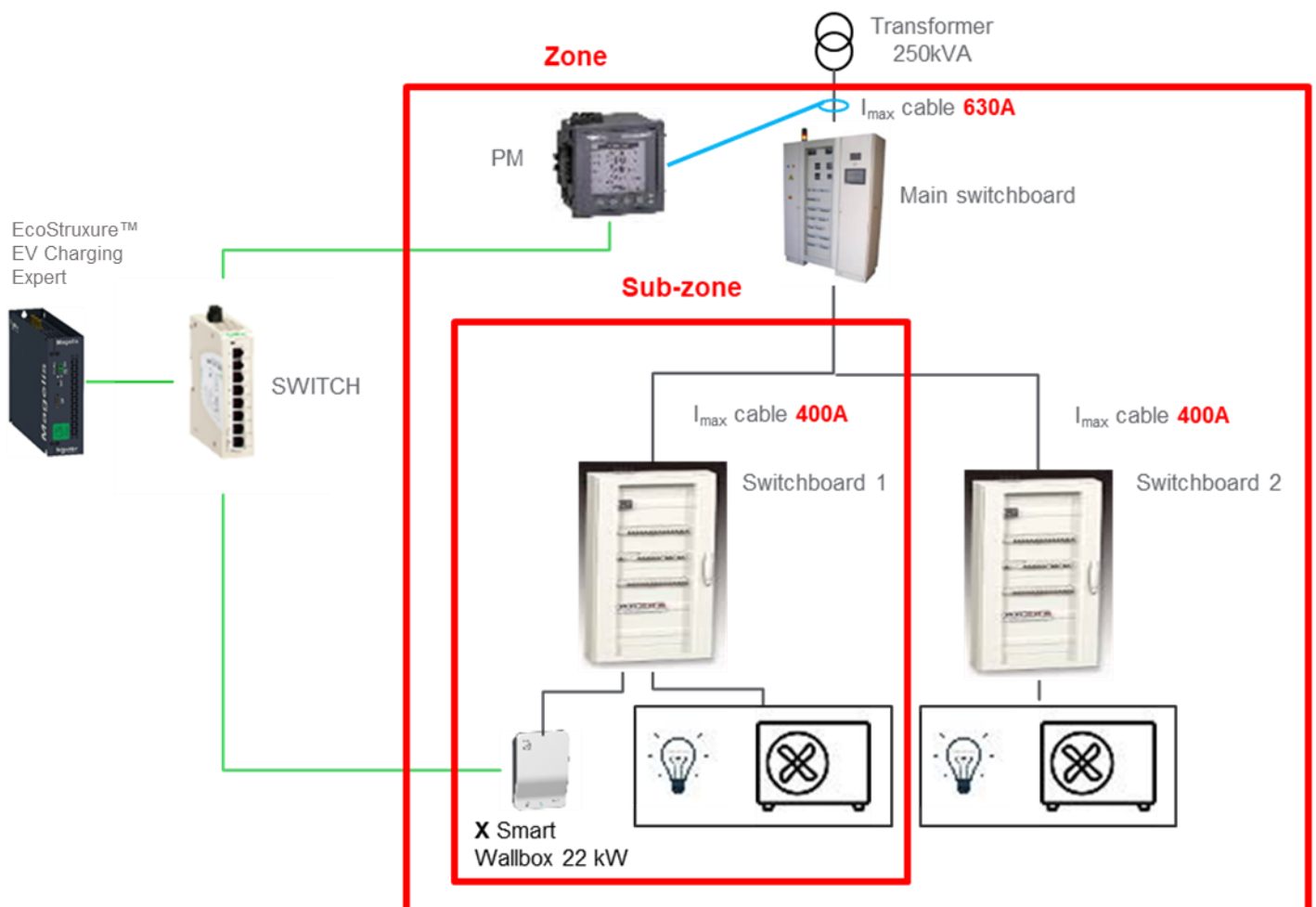



### Example #3: two zones at the same level

In this example, the main switchboard can supply both switchboards at the maximum power. Energy management is required in each zone if switchboards 1 and 2 cannot supply all charging stations and other electrical loads at the same time at the maximum power.

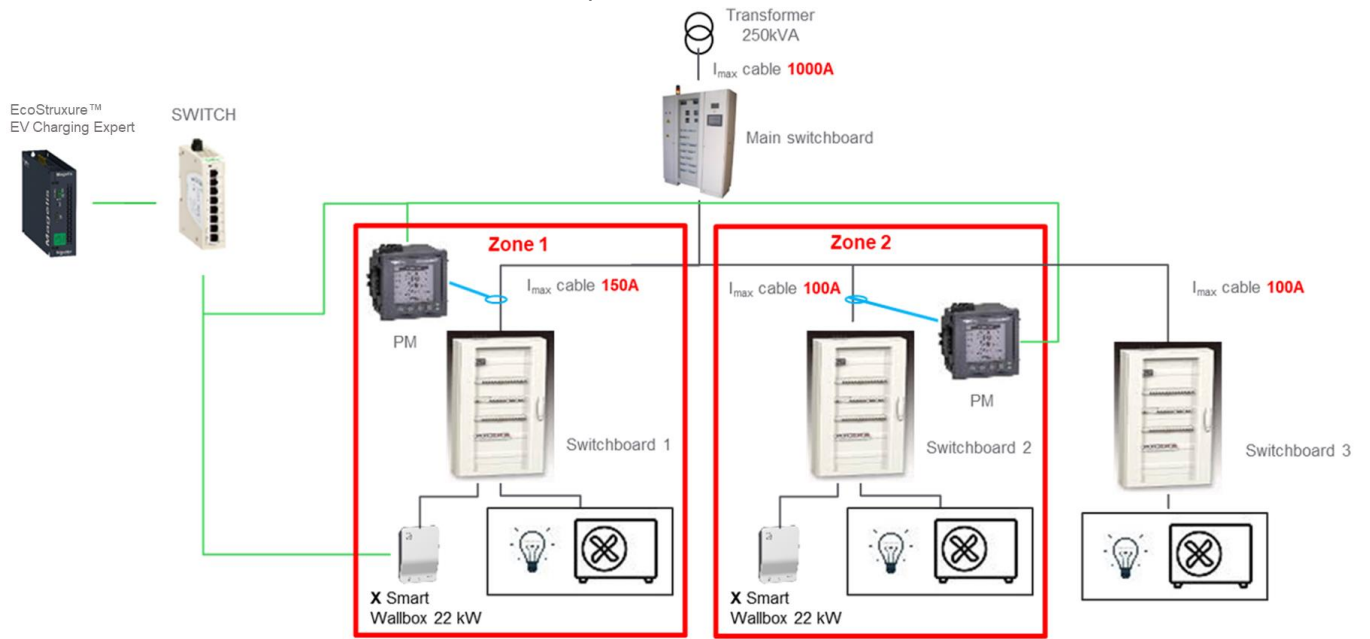

# 1.5 Commissioning of remote connection to EcoStruxure EV Charging Expert

Please go to [chapter 2 EcoStruxure EV Charging Expert COMMISSIONING](#) if you do not plan to access the EcoStruxure EV Charging Expert remotely.

## 1.5.1 Initial condition

Connect to the modem via your web browser.

### 1.5.1.1 IP Address:

EcoStruxure EV Charging Expert IP (default address): 192.168.0.128

Modem IP (default address): 192.168.0.254

Sim card IP (example): 193.192.200.10

### 1.5.1.2 Prerequisites:

Cellular configuration must be done (see NNZ2678201-01 "Instruction sheet for EVP3MM Modem)

## 1.5.2 Example of selection of the modem port:

Default EcoStruxure EV Charging Expert IP 192.168.0.128

EcoStruxure EV Charging Expert port (Port to access to the EcoStruxure EV Charging Expert dashboard): 443

Select the last two digits of the EcoStruxure EV Charging Expert IP address (28) and concatenate it to the EcoStruxure EV Charging Expert port (443)

Result: Modem Port = 28443

NOTE: the port number cannot exceed 65535

### Network schematic of the EcoStruxure EV Charging Expert remote connection

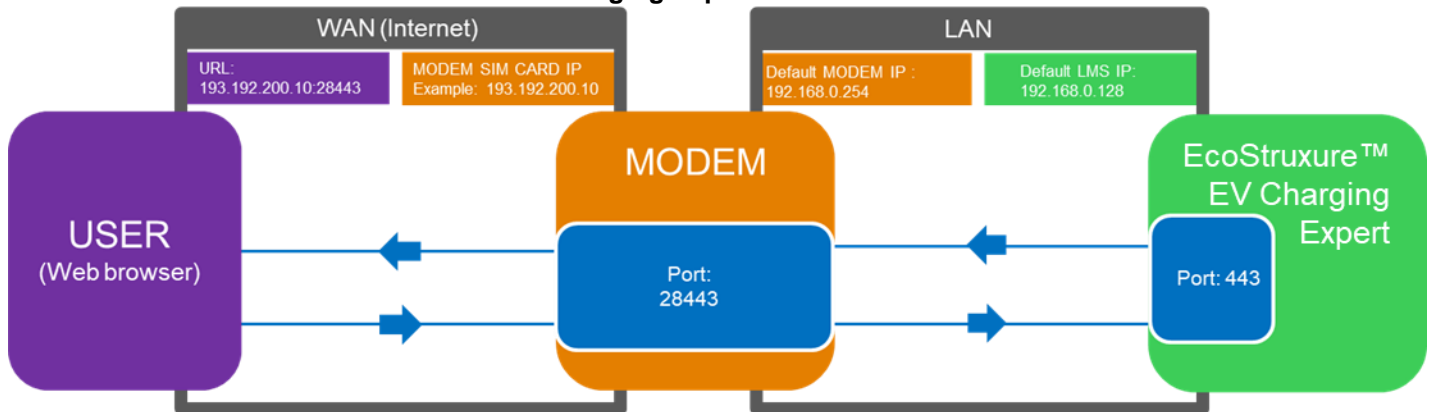

WAN: Wide Area Network

LAN: Local Area Network

### 1.5.3 Commissioning of the EVlink modem (EVP3MM)

#### 1.5.3.1 Configuration of the downstream communication channel

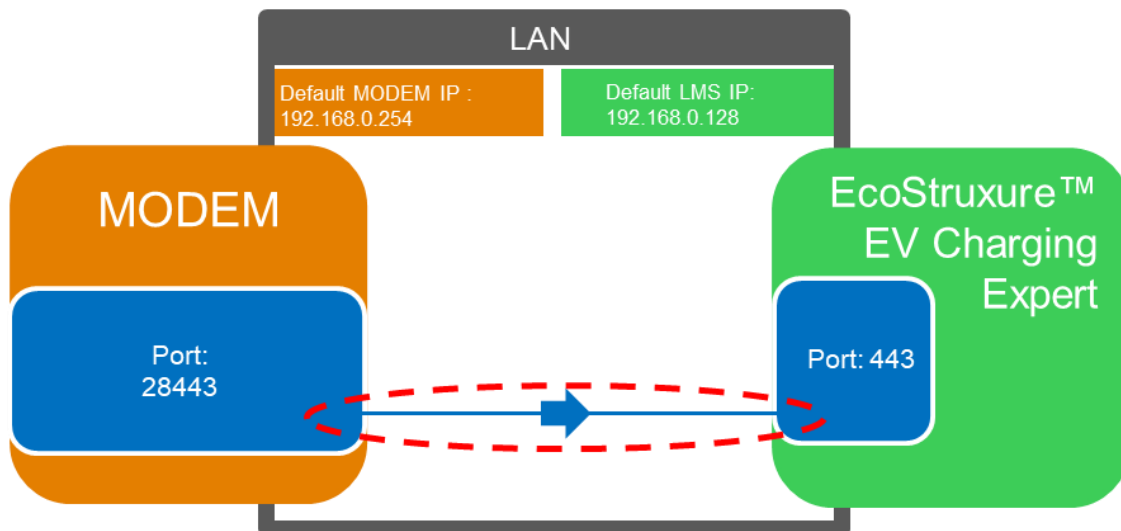

- 1/ Go to settings tab
- 2/ Check the status of the configuration  
The button must indicate "Advanced". If it is not the case, click the button.
- 3/ Click "add rule"

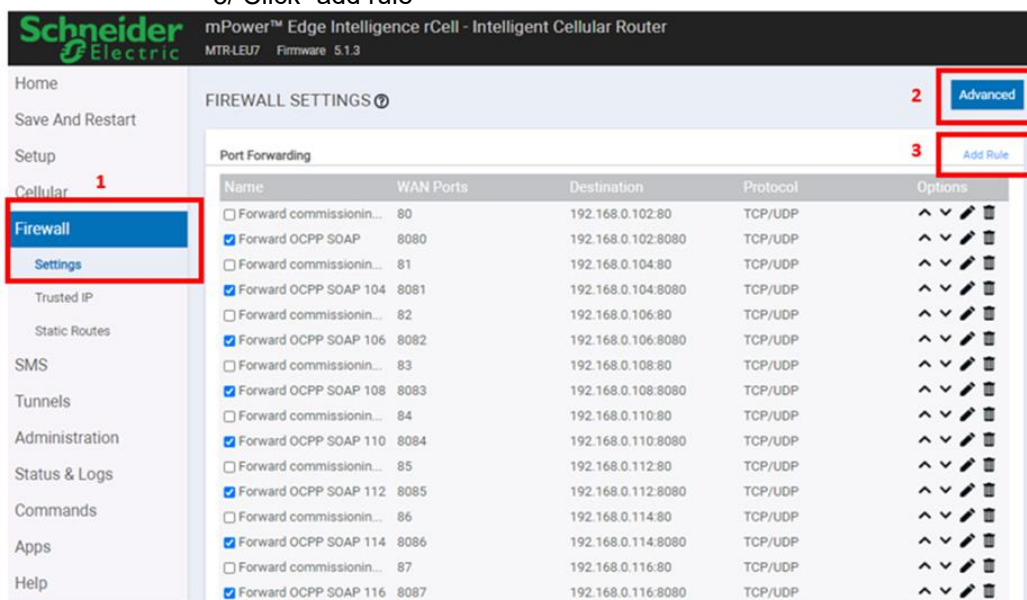

The Inbound Forwarding Rule window appears

4/ Insert the following parameters:

- Name: Indicate a name for the connection (example: Remote connection)
- WAN Port(s) (Port selected previously): 28443
- Destination LAN IP (EcoStruxure EV Charging Expert IP): 192.168.0.128
- Destination LAN Port (Port to access the EcoStruxure EV Charging Expert dashboard): 443

5/ Then click the Submit button

The screenshot shows the 'FIREWALL RULE CONFIGURATION' window for an Inbound Forwarding Rule. The configuration is as follows:

Field	Value
Name	(empty)
Description (optional)	(empty)
External WAN Port(s)	28443
Destination LAN IP	192.168.0.128
Destination LAN Port(s)	443
Protocol	TCP/UDP
External Source IP	ANY
External Source Ports	ANY
Mask	32
Enable NAT Loopback	<input type="checkbox"/>

The 'Submit' button is highlighted with a red box.

### 1.5.3.2 Configuration of the upstream communication channel

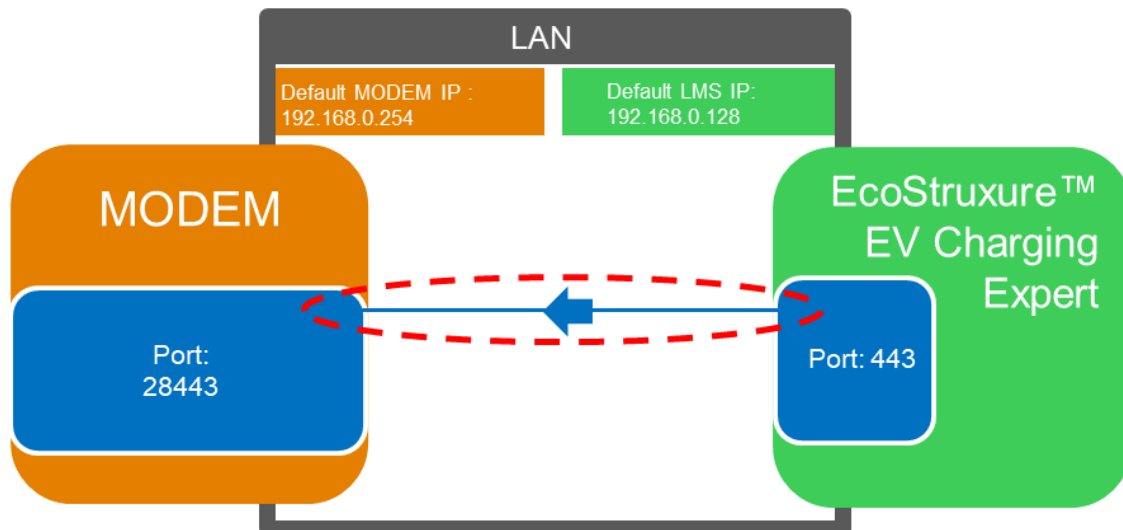

6/ Click Advanced to switch the status of the configuration to Advanced (The button should indicate Normal)

The screenshot shows the 'FIREWALL SETTINGS' page in the Schneider Electric mPower Edge Intelligence rCell configuration interface. The interface includes a left-hand navigation menu with options like Home, Save And Restart, Setup, Cellular, Firewall, Settings, Trusted IP, Static Routes, SMS, Tunnels, Administration, Status & Logs, Commands, Apps, and Help. The 'Firewall' section is selected. The main content area displays 'Prerouting Rules' with a table of rules. A 'Normal' button is highlighted with a red box in the top right corner of the settings area.

Name	Source	Destination	Protocol	NAT IP	Options
<input type="checkbox"/> Forward commis...	WAN	80	TCP/UDP	192.168.0.102:80	^ v [edit] [delete]
<input checked="" type="checkbox"/> Forward OCPP S...	WAN	8080	TCP/UDP	192.168.0.102:8080	^ v [edit] [delete]
<input type="checkbox"/> Forward commis...	WAN	81	TCP/UDP	192.168.0.104:80	^ v [edit] [delete]
<input checked="" type="checkbox"/> Forward OCPP S...	WAN	8081	TCP/UDP	192.168.0.104:8080	^ v [edit] [delete]
<input type="checkbox"/> Forward commis...	WAN	82	TCP/UDP	192.168.0.106:80	^ v [edit] [delete]
<input checked="" type="checkbox"/> Forward OCPP S...	WAN	8082	TCP/UDP	192.168.0.106:8080	^ v [edit] [delete]
<input type="checkbox"/> Forward commis...	WAN	83	TCP/UDP	192.168.0.108:80	^ v [edit] [delete]
<input checked="" type="checkbox"/> Forward OCPP S...	WAN	8083	TCP/UDP	192.168.0.108:8080	^ v [edit] [delete]
<input type="checkbox"/> Forward commis...	WAN	84	TCP/UDP	192.168.0.110:80	^ v [edit] [delete]
<input checked="" type="checkbox"/> Forward OCPP S...	WAN	8084	TCP/UDP	192.168.0.110:8080	^ v [edit] [delete]
<input type="checkbox"/> Forward commis...	WAN	85	TCP/UDP	192.168.0.112:80	^ v [edit] [delete]
<input checked="" type="checkbox"/> Forward OCPP S...	WAN	8085	TCP/UDP	192.168.0.112:8080	^ v [edit] [delete]
<input type="checkbox"/> Forward commis...	WAN	86	TCP/UDP	192.168.0.114:80	^ v [edit] [delete]
<input checked="" type="checkbox"/> Forward OCPP S...	WAN	8086	TCP/UDP	192.168.0.114:8080	^ v [edit] [delete]
<input type="checkbox"/> Forward commis...	WAN	87	TCP/UDP	192.168.0.116:80	^ v [edit] [delete]
<input checked="" type="checkbox"/> Forward OCPP S...	WAN	8087	TCP/UDP	192.168.0.116:8080	^ v [edit] [delete]

7/ Click "Add SNAT Rule" (scroll down to find the button)

The screenshot shows the 'Output Filter Rules' and 'Postrouting Rules' sections. The 'Output Filter Rules' section is currently empty, displaying 'No rules yet'. The 'Postrouting Rules' section also displays 'No rules yet'. A red box highlights the 'Add SNAT Rule' button in the top right corner of the Postrouting Rules section.

The Postrouting Rule window appears.

8/ Insert the following parameters:

- Name: Indicate a name for the connection (example: Remote connection)
- Destination LAN IP (EcoStruxure EV Charging Expert IP): 192.168.0.128
- Destination LAN Port (Port to accede to the EcoStruxure EV Charging Expert dashboard): 443
- NAT IP (Modem IP): 192.168.0.254

9/ Then click Submit.

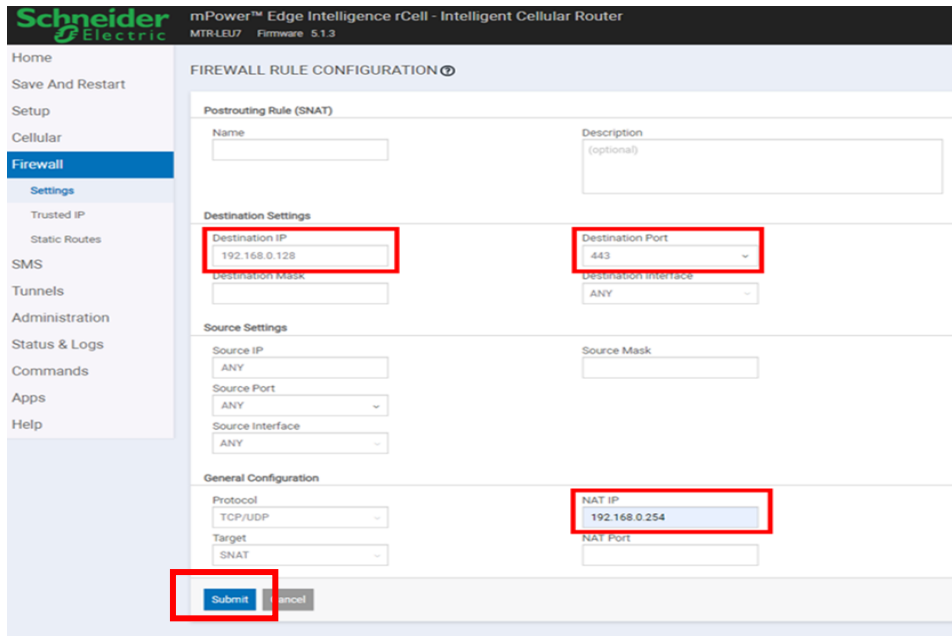

Then click on the button “Save and restart” to finish the configuration.

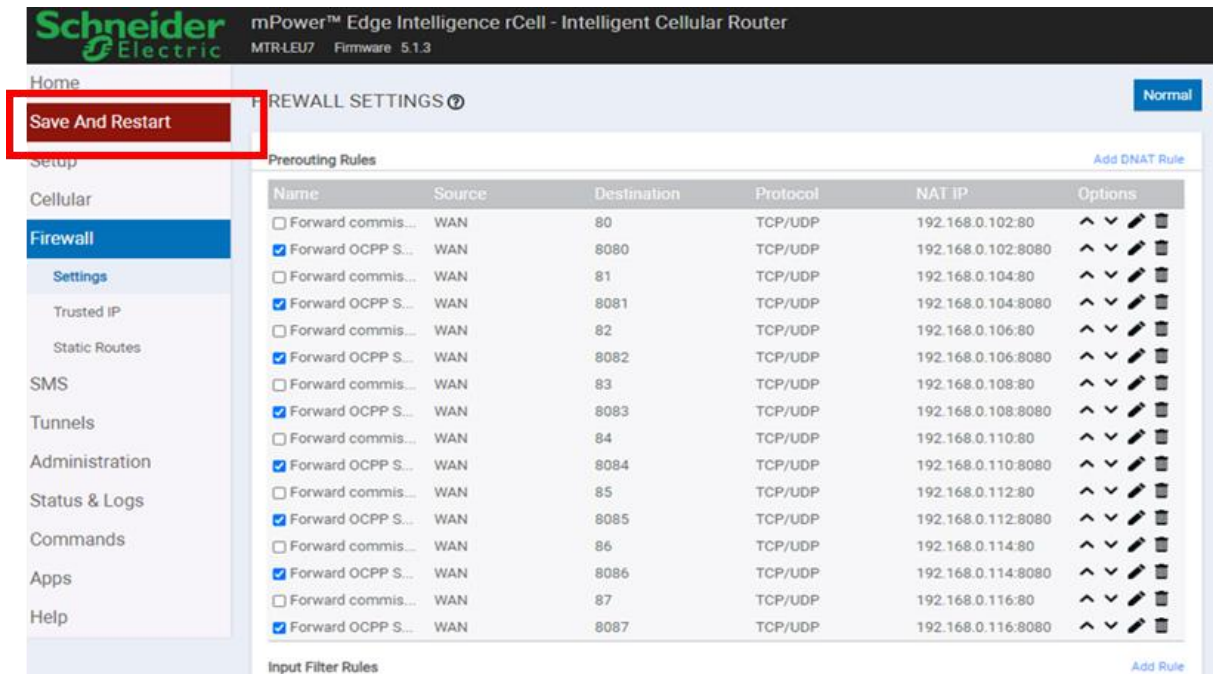

Thanks to this operation, the USER will be able to access the EcoStruxure EV Charging Expert dashboard through 193.192.200.10:28443

## Chapter 2.

# EcoStruxure EV Charging Expert COMMISSIONNING

## 2.1 Getting started with EcoStruxure EV Charging Expert

### 2.1.1 Computer configuration

Step	Action
1	Connect your computer to the EcoStruxure EV Charging Expert Ethernet network
2	Open the local network properties menu of your computer.
3	Open Internet Protocol TCP/IP v4 properties.
4	Set the static IP address properties as follows: IP address: 192.168.0.x (where x is a number between 50 and 100) Subnet mask: 255.255.255.0 No default gateway No DNS server No proxy

### 2.1.2 Login to the EcoStruxure EV Charging Expert (Wizard)

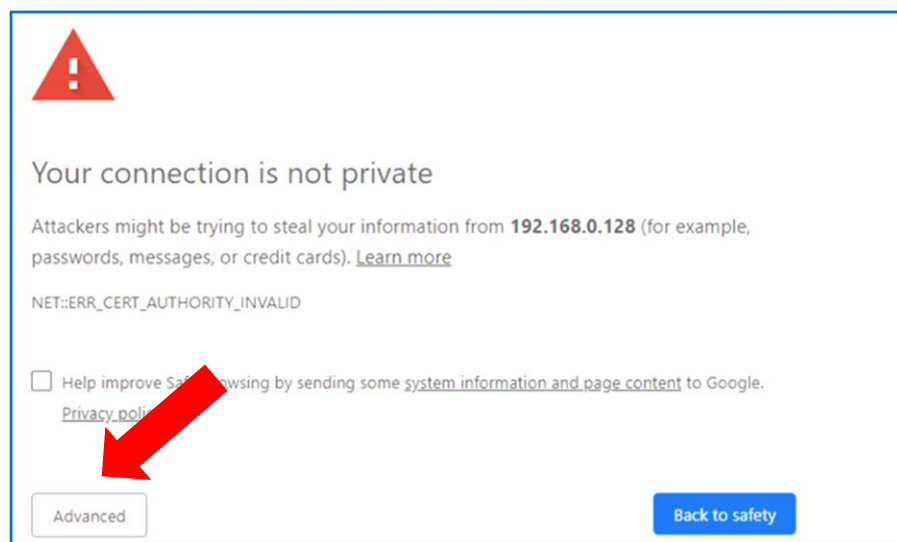
Step	Action
1	<p>Open a web browser and type 192.168.0.128 in the URL field</p> <p>If the EcoStruxure EV Charging Expert IP has been changed, you may not know its IP address. To have access to the product, you can use your computer to detect the EcoStruxure EV Charging Expert on the network. On Windows, open the Windows Explorer and click the network icon (scroll down on the left menu). After a short loading time, the EcoStruxure EV Charging Expert available on the network are displayed, named according to their reference. You can double-click on the EcoStruxure EV Charging Expert icon to open its commissioning tool.</p> <p>NOTE: Only Google Chrome web browser is compatible (72.0.3626.121 or upper)</p> <p>A security warning may be displayed: click on “Advanced” button if this occurs (see capture below)</p> <div data-bbox="456 1258 1356 1798" style="border: 1px solid blue; padding: 10px;">  </div>



Then click on "Proceed to @ ..."

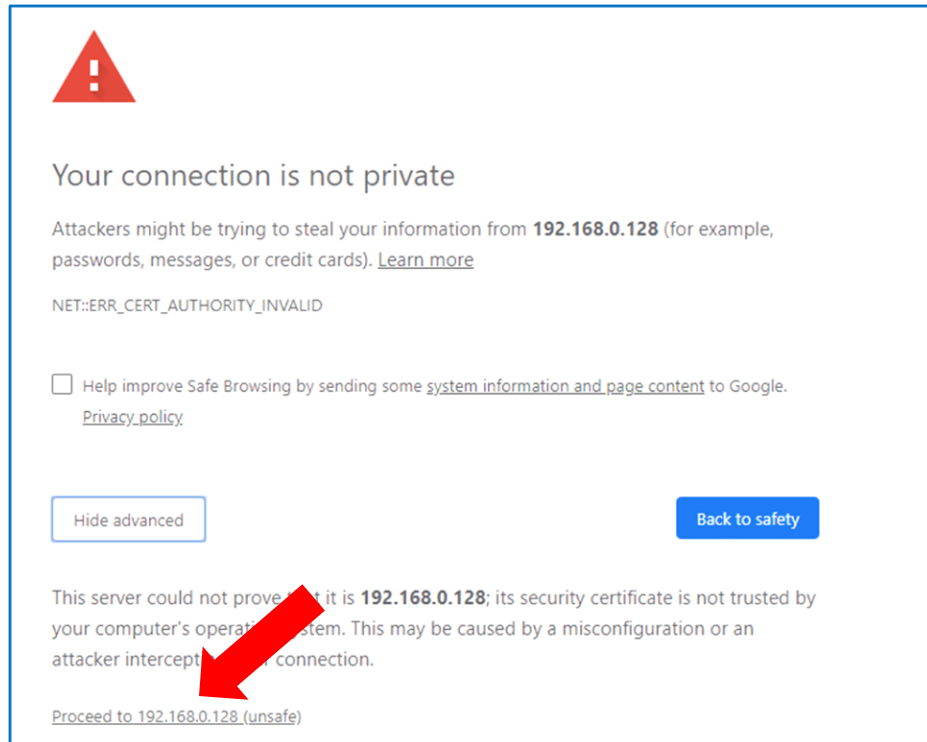

- 2 If needed Update the firmware (more details on [chapter 2.2.1](#)) or Restore the EcoStruxure EV Charging Expert (more details on [chapter 3.20.2](#)).

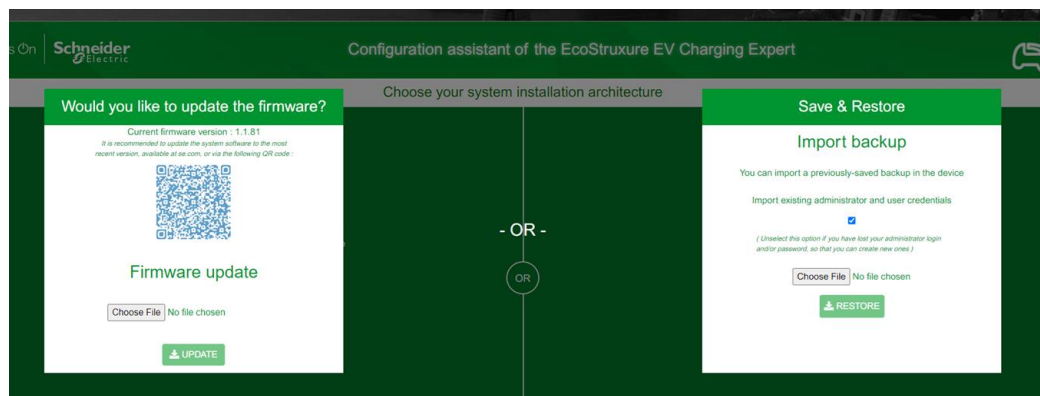

If not, click on the "X" to close the window.

- 3 Press on "Standalone" to the start the Wizard.

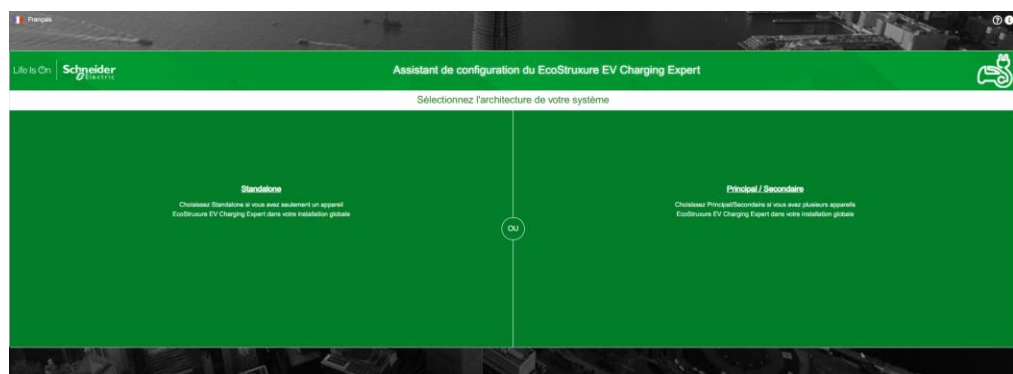

--	--

## 2.2 EcoStruxure EV Charging Expert commissioning

During the first commissioning, a configuration assistant (wizard) will guide the installer to set the EcoStruxure EV Charging Expert. If you have already done the first commissioning, please go to [chapter 3 OPERATION INTERFACE](#).



Note: During EcoStruxure EV Charging Expert commissioning or re-commissioning, current charging sessions ongoing on chargers in the network will be interrupted, since chargers will

### 2.2.1 Firmware update

It is recommended to update the product with the latest version of firmware that has been issued. The file needs to be available locally, hence the installer needs to download it previously from se.com. A QR code is provided on screen to the webpage on se.com where the latest firmware release is available. If the firmware version is already the most recent one available, click on the top right cross to close the window.

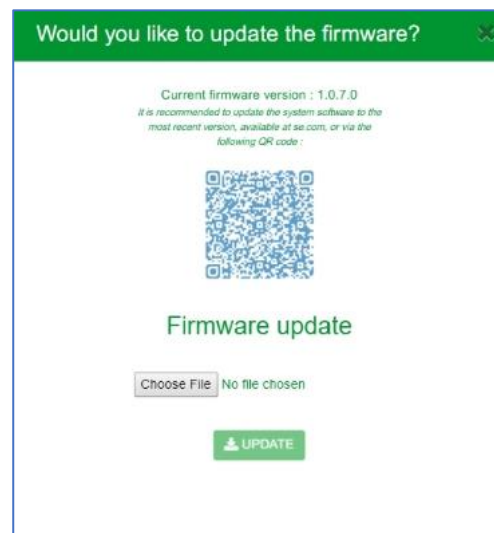

For current firmware versions equal or lower than 1.0.6.3, the QR code will not be shown on screen. In that case, please look for the latest firmware release on se.com, or use the following QR code or URL address:



<https://www.se.com/ww/en/product-range/62159-ecostruxure-ev-charging-expert/?parent-category-id=1800&parent-subcategory-id=1840&filter=business-5-residential-and-small-business#software-and-firmware>

During the firmware update process the EcoStruxure EV Charging Expert will lose connection. A message will be shown on-screen for that. That is the normal behavior. Please wait a few seconds for the connection to be reestablished, or else refresh your browser.

## 2.2.2 Administration and User password configuration

In EcoStruxure EV Charging Expert there are two different user profiles:

**Admin:** Access to all configuration parameters and features, dashboard operation and RFID card management.

**User:** Dashboard operation and RFID card management.

On the credentials step, the installer is asked to create an Administration profile and a User profile.

### 2.2.2.1 Administration & User profile creation

The installer is asked to set new administrator and new user credentials.

The passwords must have at least 8 characters, including at least 1 upper-case letter, 1 lower-case letter, 1 number and 1 special character (!, #, @, -, etc.).

The login cannot be “admin”.

Once the new profiles are created, the option to abandon the configuration assistant is enabled by means of an exit arrow symbol on the top right area of the screen.



### 2.2.3 Log in the EcoStruxure EV Charging Expert

On the configuration assistant, at different steps during the commissioning, the installer is asked to restart the EcoStruxure EV Charging Expert. At restart, after creation of administration and user account, the EcoStruxure EV Charging Expert requires to log in to continue the Wizard.

Login with Administrator credentials to have the right to continue the Wizard.



## 2.3 Network configuration

### 2.3.1 EcoStruxure EV Charging Expert name

A name must be given to EcoStruxure EV Charging Expert. It is mandatory.

### 2.3.2 Ethernet configuration

**Gateway:** A network gateway connects two networks so the devices on one network can communicate with the devices on another network.

**DNS:** Domain Name System is the naming system for computers and devices connected to a Local Area Network (LAN) or the Internet.

Fields	Access rights		Factory setting	Description
	Admin	User		
IP address	R/W	NA	192.168.0.128	EcoStruxure EV Charging Expert IP address
Network mask	R/W	NA	255.255.255.0	EcoStruxure EV Charging Expert sub-network mask
Default gateway	R/W	NA	192.168.0.254	Gateway IP address (1)
Preferred DNS system	R/W	NA	8.8.8.8	Preferred DNS server IP address (2)
Other DNS system	R/W	NA		Other DNS server IP address (2)

R/W: Read/Write - NA: Not Available

- (1) Address of the modem used for the connection to the supervision, if any. All charging stations on the same sub-network than EVCE, will be also configured with this gateway.
- (2) DNS Server is used to convert URL to IP address. May be provided by the remote supervision (through a dedicated SIM card for example). Google DNS server by default. Avoid the use of "50" as the last octet on IP addresses (that is, X.Y.Z.50 is forbidden).



Note: If the EcoStruxure EV Charging Expert sub-network (**192.168.0.128**) is changed, the sub-network of the computer must also be changed after the reboot of the EcoStruxure EV Charging Expert.

### 2.3.3 DHCP server configuration

**DHCP:** Dynamic Host Configuration Protocol is a protocol used to provide quick, automatic, and central management for the distribution of IP addresses within a network.

EcoStruxure EV Charging Expert can be configured to act as a DHCP server to assign IP addresses to charging stations in the defined range, provided that they are configured to support this feature.

Settings	Access rights		Factory setting	Description
	Admin	User		
DHCP range high	R/W	NA	192.168.0.250	DHCP range high IP address limit
DHCP range low	R/W	NA	192.168.0.200	DHCP range low IP address limit

R/W: Read/Write - NA: Not Available



Note: Restrictions on charging stations IP addresses:

- Avoid the use of "50" as the last octet on charging stations IP addresses (that is, X.Y.Z.50 is forbidden)
- Avoid the use of sub-network addresses +0, +1, +MAX, +MAX-1. If the by-default sub-network (192.168.0.0-255) is being used, avoid the use of 192.168.0.0, 192.168.0.1, 192.168.0.254 and 192.168.0.255.



Note: Check with the building IT manager if the DHCP is already activated on the same network as the EcoStruxure EV Charging Expert. If yes, do not activate DHCP on the EcoStruxure EV Charging Expert.

## 2.4 Charging stations commissioning

### 2.4.1 Prerequisites

Charging stations must be powered on and connected to the Ethernet network prior to the EcoStruxure EV Charging Expert commissioning.

Charging stations must have a compatible firmware version, see [chapter 1.1.2.1 EVlink charging stations](#)

**WARNING:** You must close all charging stations webserver before starting the installation



Note: Restrictions on charging stations IP addresses and box identities:

- Avoid the use of "50" as the last octet on charging stations IP addresses (that is, X.Y.Z.50 is forbidden)
- Avoid the use of sub-network addresses +0, +1, +MAX, +MAX-1. If the by-default sub-network (192.168.0.0-255) is being used, avoid the use of 192.168.0.0, 192.168.0.1, 192.168.0.254 and 192.168.0.255.
- Charging stations box identities must not contain any space.

### 2.4.2 Charging station landing page

### 2.4.3 Description

Icons	Description
	Show all charging stations on the network
	Filter charging station displayed on the Screen by name, zone ...
	Add manually a charging station not scanned by the EcoStruxure EV Charging Expert
	Save settings

### 2.4.4 Filter Charging Stations

To configure the charging stations, it is useful to have filtering functionalities. The EcoStruxure EV Charging Expert proposes filtering by:

- Hiding charging stations that are already registered
- Station name



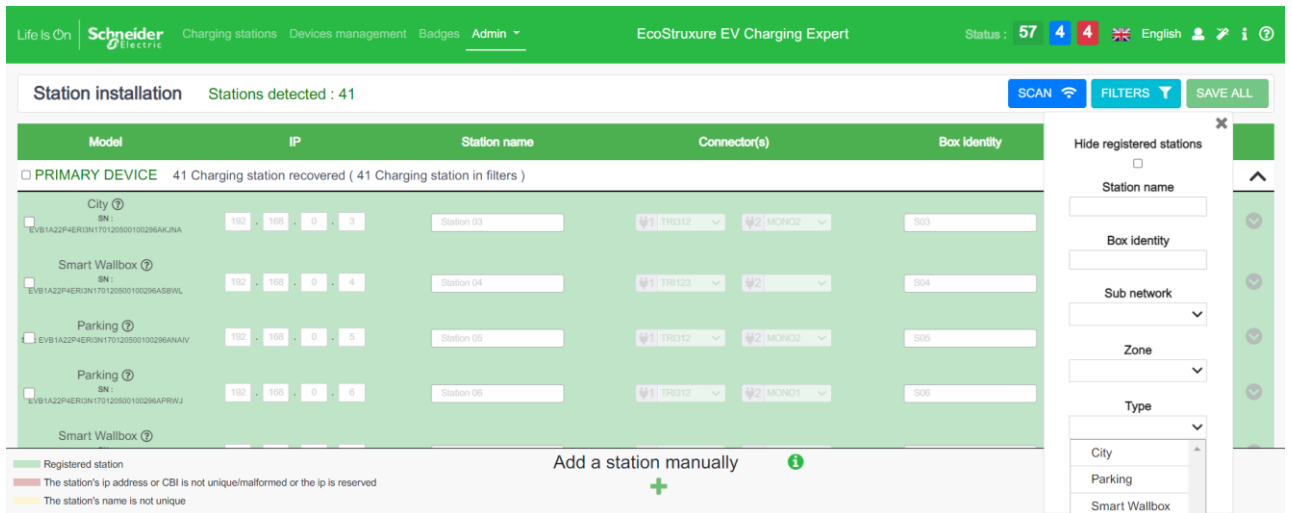

- Box Identity
- Sub Network
- Zones
- Type of charging station: EVlink Pro AC, EVlink City, Parking, Smart Wallbox, Fast Charge

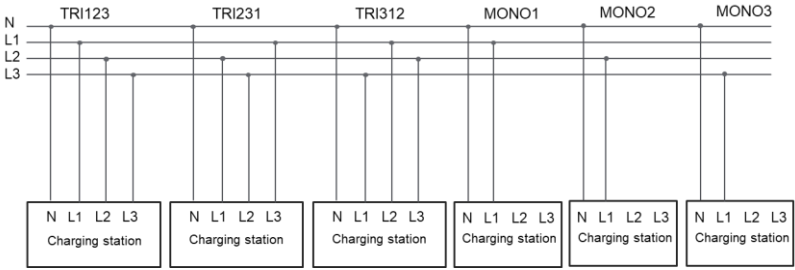

### 2.4.5 Charging station configuration

Steps	Description
1	Click
2	<p>If a charging station is not scanned automatically by the EcoStruxure EV Charging Expert, add it manually by clicking on this icon </p> <div style="text-align: center; border: 1px solid gray; padding: 10px; margin: 10px 0;"> <p>Add a station manually </p> <p></p> </div> <p>A popup will open, and you must enter all the fields in the form. Must enter the Ip address, type of station (City/Parking/Smart Wallbox or EVlink Pro AC), the subnetwork and the serial number*.</p> <div style="text-align: center; border: 1px solid gray; padding: 10px; margin: 10px 0;"> <p>Add a station <span style="float: right;">×</span></p> <p>Sub network <span style="color: red;">*</span></p> <p>Type <span style="color: red;">*</span></p> <p>IP Address <span style="color: red;">*</span></p> <p>Serial number <span style="color: red;">*</span></p> <p style="font-size: small;">serial number</p> <p style="text-align: center;"> <span style="background-color: #0070C0; color: white; padding: 2px 10px;">CONFIRM</span> <span style="background-color: #808080; color: white; padding: 2px 10px;">CANCEL</span> </p> </div> <p>*: See <a href="#">chapter 2.4.6</a> to know how to get the Serial Number of your charging station.</p>
3	Click on
4	<p>Update charging station settings:</p> <ul style="list-style-type: none"> <li>- <b>IP Address:</b> Change this parameter if the building IT manager imposes fixed IP addresses (avoid X.Y.X.50)</li> <li>- <b>Station name:</b> It is recommended to select a name that indicates the location of the station and the name of the parking (50 characters max)</li> <li>- <b>Connector(s):</b> in order to optimize load management, it is recommended to rotate the phases of the charging stations installed on the same site. Select</li> </ul>

Steps	Description
	<p>here the phase wiring of each connector of the charging station according to the electrical wiring as implemented in the electrical network. e.g.</p>  <ul style="list-style-type: none"> <li>- <b>VIP:</b> Check the box to activate the VIP status to the charging station.</li> <li>- <b>Version:</b> Firmware version embedded in the charging station.</li> <li>- <b>Box identity:</b> If the EcoStruxure EV Charging Expert is connected to a remote supervision insert here the box identity provided by the Charge Point Operator (CPO). By default, it is the charging station MAC address. The box identity must not contain spaces.</li> <li>- <b>Zones:</b> Zone assignment will be done in a later step.</li> </ul>
5	<p>Modify the authentication mode on the station. For that purpose, click on . Then select the authentication mode and the authentication mode when disconnected.</p> 
6	<p>Click the “Save All” button to initiate the configuration of the charging stations</p>
7	<p>Click “Next” to complete the step</p>



Note: If the installation of a charging station does not succeed (marked with a red cross). In that case please relaunch the installation of the charging station.

During the configuration of the charging stations, the EcoStruxure EV Charging Expert will automatically update the firmware of the charging stations in the network to the charging station firmware version embedded in the EcoStruxure EV Charging Expert firmware.

## 2.4.6 Get the serialNumber of a charging station

### 2.4.6.1 Get the serialNumber of a City, Parking or Smart Wallbox

To find the serialNumber of your charging station, you need to go in its webserver ( the webserver of a charging station is at its IP address: <https://x.x.x.x> ) and log in: (default credentials are admin / ADMIN)

\*: If https address is not working, try the same address in http → <http://x.x.x.x>

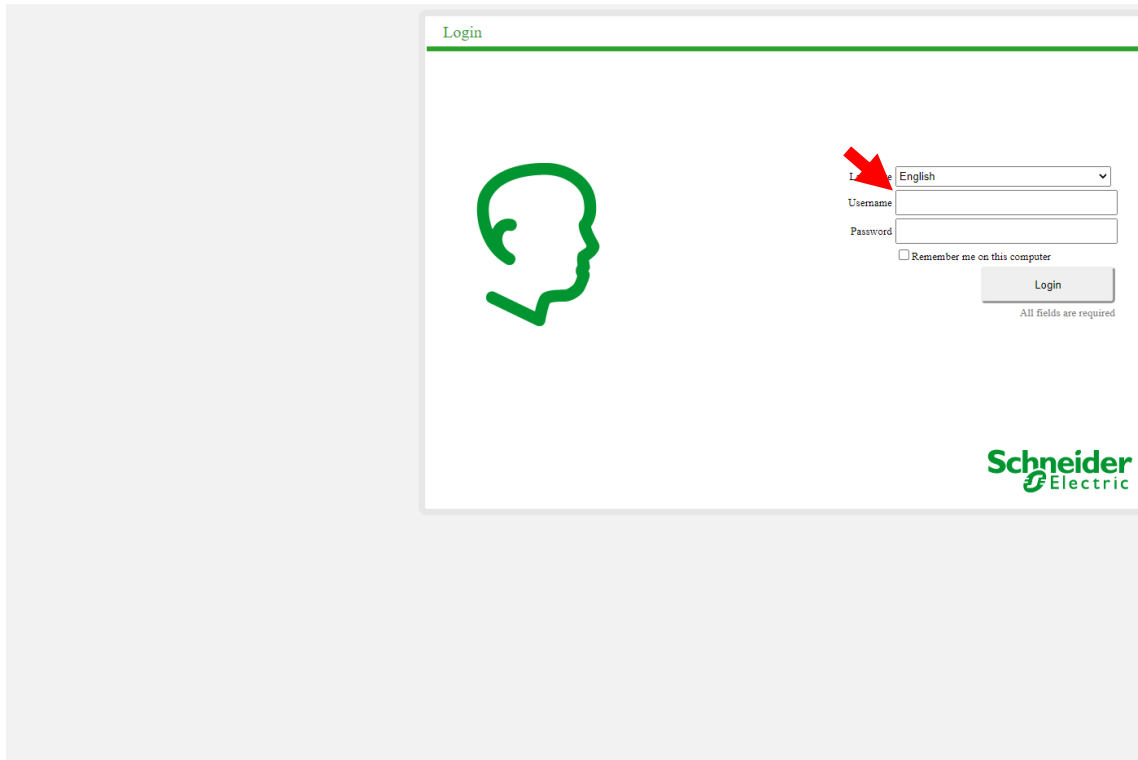

Once you are in the webserver, go in the maintenance → report tab :

**Maintenance Report**

**Product Number**

	Plug #1	Plug #2
Commercial Ref	EV.1B22P22R	EV.1B22P22R
Factory Code	3N	N
Production Date	20245	0245
Production Revision	30	0
Batch Number	004	04
Unique Identifier	001	01
Product Id	5049A39	049A39
Serial Number Part 1	3N200850552C1	3N200850552D1
Serial Number Part 2	S1B7551700017	S1B7551700017

**Evse Status**

	Plug #1	Plug #2
FW version	3400	3400
FW build number	1	1
Web version	3400	3400
Webserver build number	1	1
Boot Counter	7	7
CPW state	EVSE_NotAvailable__StateF	EVSE_NotAvailable__StateF
Cable state	Not_Plugged	Not_Plugged

In this tab, when the Maintenance Report of the charging station is displayed, you will need to concatenate all the fields that are in the red square, and remove the "." ( if present ) in the commercial ref.

So, in this example, the serialNumber of your charging stations is **EV1B22P22R3N20245300040015049A39**

### 2.4.6.2 Get the serialNumber of a EVlink Pro AC or EVlink PRO AC Metal

The Serial number of EVlink Pro AC can be found in the maintenance report

#### Maintenance report

Report generated on Wednesday, January 5 2022 at 03:22:03 pm [Download zip](#)

#### Product information

General information	
Product name	EVlink Pro AC - 20235
Product range	EVlink Pro AC
Commercial reference	EVB3S07N4A
Production date	2021-01-19
Serial Number	A21312020235
Hardware configuration	
Phases number	MONO
T2 socket type	T2S
Domestic socket type	N/A
Embedded RCD	Type Asi
6mA protection	Yes
Internal MID	No
Hardware versions	
Motherboard	MFR67543-05
HMI	MFR67542-01
Metering	MFR67543-02

or on the sticker of the product

**EVB3S22N4E**
**EVlink Pro AC**

Electric vehicle charging station 22kw T2S TE iMNx  
 Borne de recharge pour véhicule électrique 22kw T2S TE iMNx  
 Станция зарядная для электромобиля 22кВт T2S TE iMNx

U (V AC): 220/240 1 P+N+PE 380/415 3 P+N+PE	T(°C): -30/50	
I MAX (A): T2: 32 TE: 10	IEC/EN 61851-1	
F(Hz): 50/60	IEC 61851-21-2	
IP54 / IK10	IEC 61439-7	

Made in France SN : M YY WW D RR LL NN





Schneider Electric CS 30323 F - 92506 Rueil-Malmaison Cedex

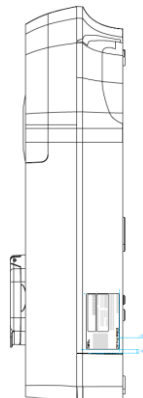

## 2.5 Power meter configuration

### 2.5.1 Prerequisites

**Reminder:** Power meters are only required in EcoStruxure EV Charging Expert dynamic mode. Their Ethernet connection must be configured (See [chapter 1.3.1.2 Power meter connection](#)) regardless of the EcoStruxure EV Charging Expert and prior to the EcoStruxure EV Charging Expert commissioning

### 2.5.2 Power meter landing page

Status	Name	Model	Network configuration	Internals (A)	Energy (kWh)	Power (kW)	Edit/Remove
✓	PowerMeter1 <small>Import</small>	MTZ	TCP 192.168.42.502#255	8 / 16 / 5		1.2	0
✓	PowerMeter2	MTZ	TCP 192.168.42.43.502#255	8 / 16 / 5		1.2	0
✓	PowerMeter3	MTZ	TCP 192.168.42.44.502#255	8 / 16 / 5		1.2	0
✓	SolarNorthPowerMeter <small>Local Prod</small>	MTZ	TCP 192.168.42.45.502#255	8 / 16 / 5		1.2	0
✓	SolarSouthPowerMeter <small>Local Prod</small>	MTZ	TCP 192.168.42.46.502#255	8 / 16 / 5		1.2	0
✓	WindPowerMeter <small>Local Prod</small>	MTZ	TCP 192.168.42.47.502#255	8 / 16 / 5		1.2	0
✓	HydroPowerMeter <small>Local Prod</small>	MTZ	TCP 192.168.42.48.502#255	8 / 16 / 5		1.2	0
⚠		MTZ	TCP 192.168.0.0.502#255	0 / 0 / 0		0	0

Name:

XTU

Local Production

Reporting

Model:

IP address:     IP address

Port:

SlaveID:

Icons	Access rights		Description
	Admin	User	
	Yes	No	Add a new power meter
	Yes	No	Update the power meter parameters
	Yes	No	Remove the power meter
	Yes	No	Power meter correctly connected
	Yes	No	Power meter not connected
	Yes	No	Connection not established with the power meter (EcoStruxure EV Charging Expert reboot may be need)

### 2.5.3 Power meter setting

#### Description

RTU and TCP are both communication protocols used by Schneider Electric power meters. If the RTU check box is not selected, it means that the communication is TCP. In such cases, please follow instructions in the table below to create the power meter in the EcoStruxure EV Charging Expert.

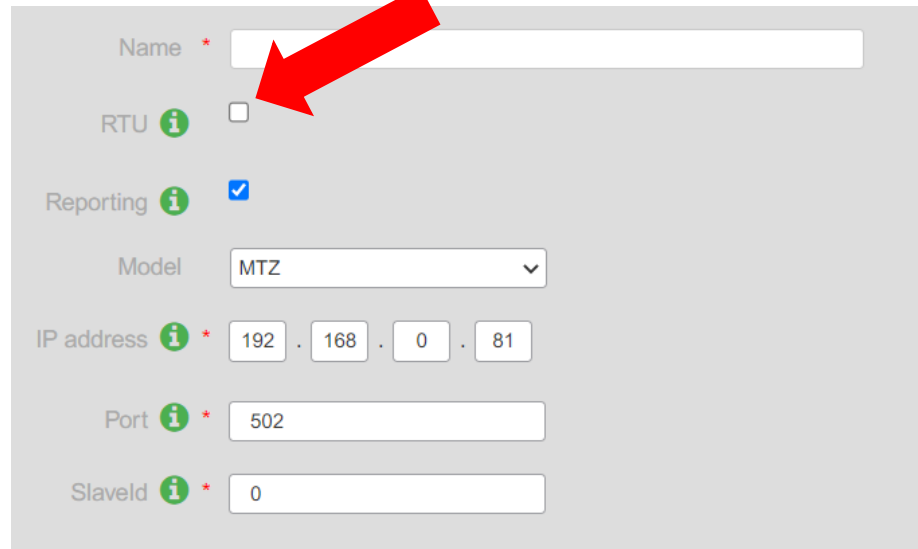

The screenshot shows a configuration form for a power meter. A red arrow points to the 'RTU' checkbox, which is currently unchecked. The 'Reporting' checkbox is checked. The 'Model' dropdown is set to 'MTZ'. The 'IP address' is 192.168.0.81, 'Port' is 502, and 'Slaveld' is 0.

Settings	Access rights		Range	Factory setting	Fields to enter per protocol and per settings		Description
	Admin	User			RTU	TCP	
Name	R/W	NA			X	X	Power meter name (Please select an unambiguous name, where the power meter is located  example: main switchboard power meter)
Protocol	R/W	NA	TCP	X		X	Power meter communication protocol
			RTU		X		
Reporting (1)	R/W	NA	No	X	X	X	Select this option when Power meter is used to register consumption of electrical loads other than charging stations
			Yes		X	X	
Model	R/W	NA	IEM3x5x		X	X	Power meter model.
			PM5320			X	
			PowerTag			X	
			NSX / NSX Legacy (3)			X	
			Masterpact MTZ			X	
IP address (2)	R/W	NA				X	Power meter IP address:  Avoid the use of "50" as the last octet on IP addresses (that is, X.Y.Z.50 is forbidden).

Settings	Access rights		Range	Factory setting	Fields to enter per protocol and per settings		Description
	Admin	User			RTU	TCP	
							Indicate the parameters that have been configured during the commissioning of the power meter (see <a href="#">chapter 1.3.1.2 Power meter connection</a> )
Port (2)	R/W	NA		502	X	X	Power meter TCP port:  Indicate the parameters that have been configured during the commissioning of the power meter (see <a href="#">chapter 1.3.1.2 Power meter connection</a> )
Slave Id	R/W	NA	1 - 255	255	X	X	Power meter slave Id:  Indicate the parameters that have been configured during the commissioning of the power meter (see <a href="#">chapter 1.3.1.2 Power meter connection</a> )

- (1) Availability depends on supported EcoStruxure EV Charging Expert reference
  - (2) Mandatory only when TCP protocol is selected
  - (3) Some early versions of Compact NSX circuit breakers may require selecting "NSX Legacy" as power meter
  - (4) [See chapter 1.1.2.2 Power meters](#)
- R/W: Read/Write - NA: Not Available

As soon as the power meter(s) are defined and updated, the success of the connection is verified and shown on screen. A successful connection will carry an



icon on each power meter line.

## 2.5.4 Power meter models

Power meter models allow to manage a list of custom power meter models. To access the Power meter models, go to Admin -> Configuration -> Tab Power meters -> Sub-tab Define Power Meter Models

The user can't view, update or delete the default list of power meter models. See the default list in [1.1.2.2 Power meters](#).

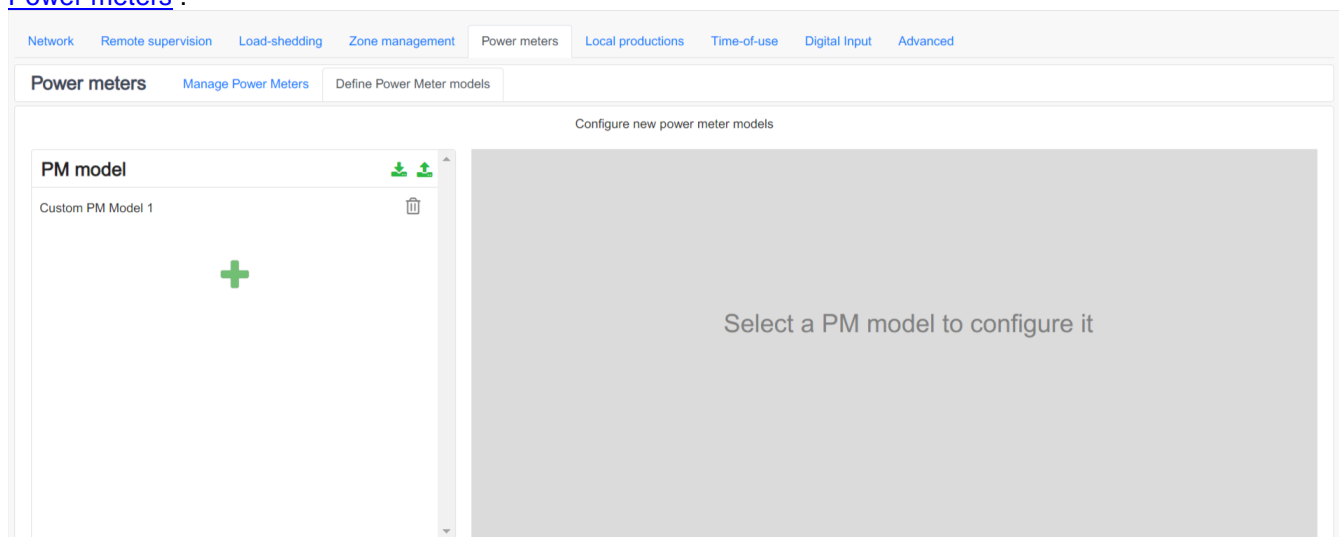

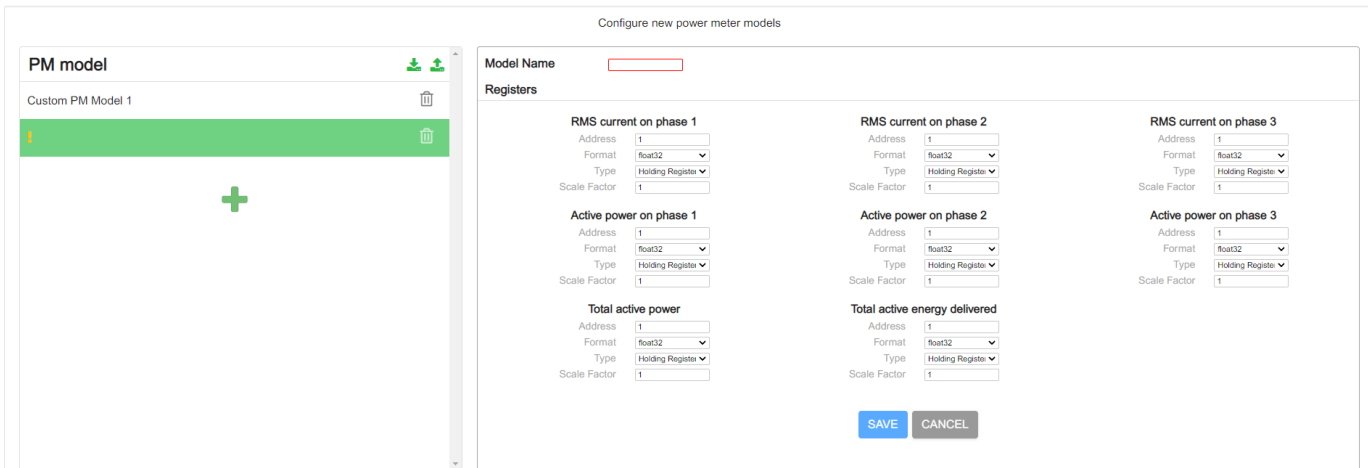

### 2.5.4.1 Create power meter model

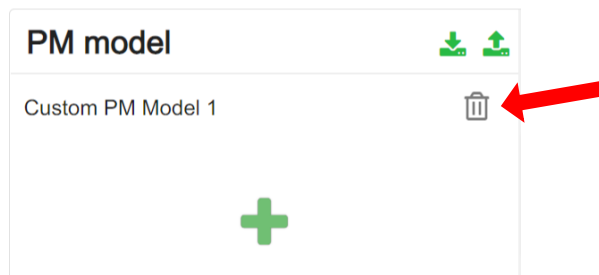

1. Click on **+**, to initialize a new power meter model.
2. Enter a name to your new model.
3. Fill in the fields in each register
  - Address
  - Format (Float32, Int64, Int32, Uint16)
  - Type (Holding Register/Input Register)
  - Scale factor
4. Click on **SAVE** button to save your new power meter model

### 2.5.4.2 Delete power meter model



Click on  to delete your power meter model

### 2.5.4.3 Use a power meter model

Access to Manage Power Meter's Tab to use your new Power meter model.

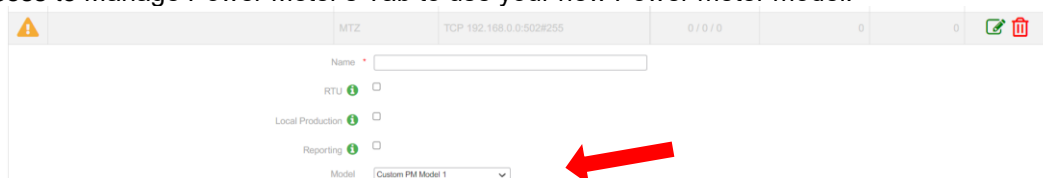



#### 2.5.4.4 Export power meter models

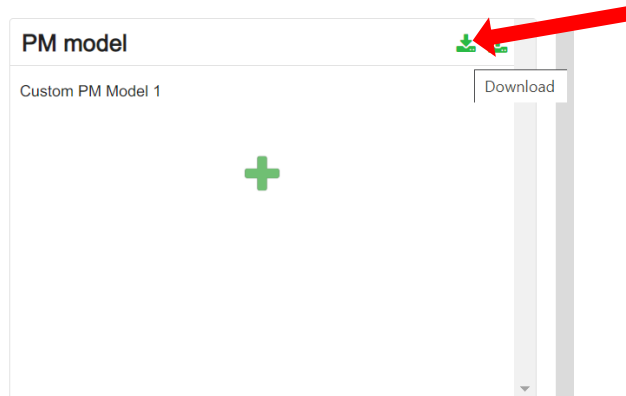

Download and export your list of power meter model via this button.

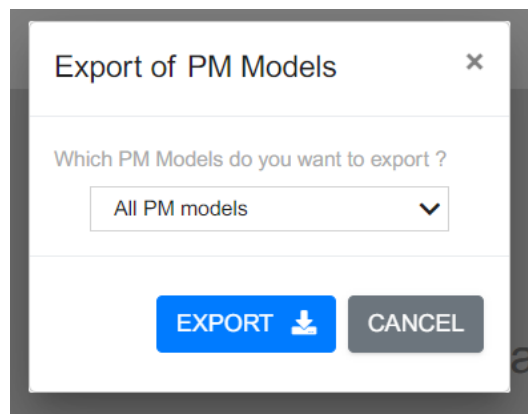

You can select some or all your power meter models in the export interface.

#### 2.5.4.5 Import power meter models

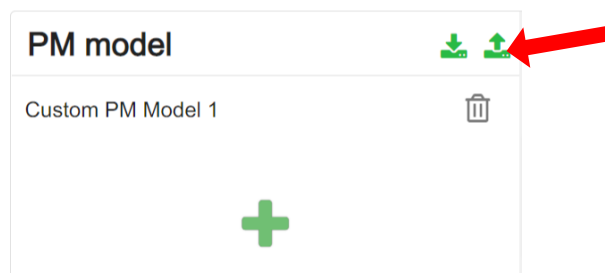

Import your list of power meter model via this button in your device.

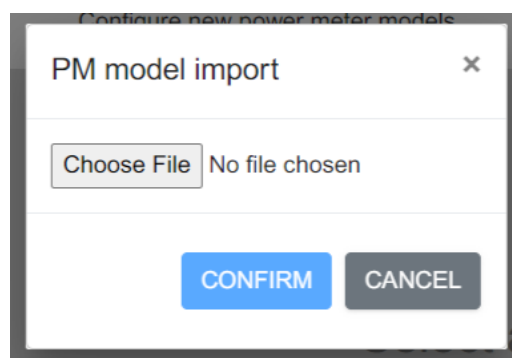

Select a file of power meter models to import in your EcoStruxure EV Charging Expert.

## 2.6 Zone configuration

### 2.6.1 Prerequisites

Reminder: Each zone and subzone to be created will need a maximum current setpoint defined for it. Zones or subzones to be managed with a dynamic energy management directive will need a power meter (configured in the previous step) assigned to each of them. Zones or subzones in static energy management directive don't require a power meter.

### 2.6.2 Zone configuration

Name	Max intensity	Energy management directive	Power meter	Authentication mode
+ 1st Floor	200	Static		-
+ 1st Floor - North	150	Static		-
+ 1st Floor - South	150	Static		-
+ 2nd Floor	400	Static		-
+ 2nd Floor - North	250	Static		-
+ 2nd Floor - North-East	150	Static		-
+ 2nd Floor - North-West	150	Static		-
+ 2nd Floor - South	250	Static		-
+ 3rd Floor (VIP)	200	Dynamic	PowerMeter2	-

EcoStruxure EV Charging Expert can manage different zones and subzones based on the electrical architecture deployed in the installation. Please refer to [chapter 1.4](#).

The configuration assistant allows the installer to define the name of each zone and its sub-zones, as well as its maximum current setpoint (maximum intensity), the energy management mode for the zone, and the power meter to associate to the zone if the energy management mode is dynamic.

Icon	Access rights		Description
	Admin	User	
	Yes	No	Add a new zone
	Yes	No	Save the zone configuration
	Yes	No	Delete a zone

### 2.6.3 Zone creation

Step	Comments
1	Click on <b>+</b> next to <b>Name</b> to create a zone. Several zones can be created depending on the EcoStruxure EV Charging Expert reference (see table in <a href="#">chapter 1.1.1.3</a> ).
2	Click on <b>+</b> next to <b>Zone</b> to create a sub-zone. Several sub-zones can be created depending on the EcoStruxure EV Charging Expert reference.
3	Set the maximum intensity allowed in each zone and sub-zone. <b>Note:</b> <ul style="list-style-type: none"> <li>- <b>The value must be lower or equal to the electrical capacity of the installation.</b></li> <li>- <b>Max intensity in a sub-zone cannot be higher than the maximum intensity in the related zone.</b></li> </ul>
4	In dynamic mode, select the power meter measuring the zone current. A power meter is assigned to a single zone and cannot be shared.
5	By default the new zone is in <b>Static</b> mode. Select a power meter to put it in <b>Dynamic</b> mode. The power meter measures the zone current. It is assigned to a single zone and cannot be shared.  Static mode: The maximum power setpoint value for the charging stations is equal to the subscribed demand or any fixed value.  Dynamic mode: The remaining power at the building level is allocated to the charging infrastructure in real time.
6	For the dynamic zone, set a <b>Default Setpoint</b> to be used when the communication is lost with the PM (see <a href="#">chapter 2.6.4.2</a> ).  
7	If the dynamic mode is selected, select a Power Meter to measure the zone current. A power meter is assigned to a single zone and cannot be shared.
8	Select an authentication mode for the zone.
9	Click on <b>+</b> to save the current zone.

### 2.6.4 Degraded Mode

The EcoStruxure EV Charging Expert define a degraded mode on the energy management of a zone, permitting vehicles to continue loading safely, when communications issues appear.

#### 2.6.4.1 Degraded mode for a static zone

For a static zone, the EcoStruxure EV Charging Expert defines the intensity that the charging station will deliver, **when the communication is lost with the EcoStruxure EV Charging Expert.**

To calculate the degraded mode to apply to each charger, the EcoStruxure EV Charging Expert verify first that the Maximum Intensity set by the user for the zone permits each charger to have the minimum intensity defined. It can be 6, 8 or 14A according to the user choice in [chapter 2.9.3](#):

- IEC 61851: the setpoint is 6A in single phase and tri phases
- EV/ZE ready: 8A single phase and 14A on tri phases

Note that for this calculation, there is cases:

- The TE charger or the Smart Wallbox with one TE/T2 card, will have a setpoint at 10A
- The EVlink City charging station will have a setpoint at 14A

If the Maximum Intensity is:

- Enough, the degraded mode is equal to 6, 8 or 14 A (or 10 for TE) multiplied by scale factor ( $\geq 1$ ) for each disconnected charger. The scale factor allows to use the maximum intensity defined even when in degraded mode.
- Not enough: the degraded mode is equal to zero (0) for each disconnected charger, meaning that no vehicle can load.

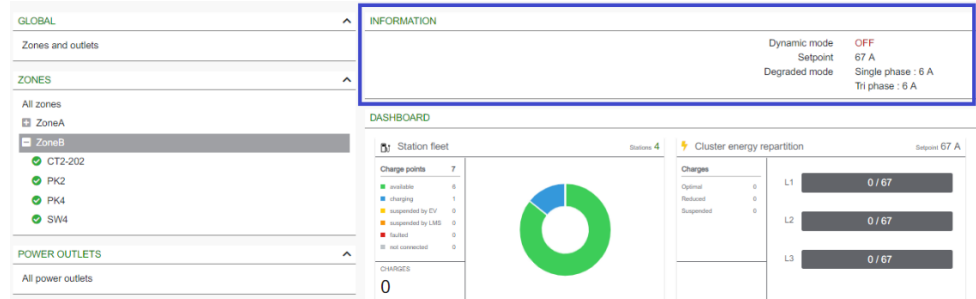

**Example – Degraded mode calculation:**

The static zone PARK1 has 3 Charging stations:

- Two (2) EVlink Parking T2
- EVlink SmartWallBox T2/TE

The Maximum setpoint is 51A

The EcoStruxure EV Charging Expert calculate the minimum setpoint needed for the charging stations, taking into account the IEC 6185 standard chosen:

- Each EVlink Parking T2 need: 2 chargers \* 6A =12 A.
- EVlink SmartWallBox T2/TE: 10A

The minimum setpoint needed for all charging stations is 34A (12A+12A+10A).

The scale factor is  $51A/34A = 1.5$

Conclusion: the degraded mode will be 9A for each EVlink Parking T2 and 15A for EVlink SmartWallBox because the maximum intensity is enough.

For the remaining charging stations that still be connected to the EcoStruxure EV Charging Expert, the maximum current to share is equal to: **the Maximum Intensity set for the Zone** minus (-) **the sum of default setpoint of disconnected charging stations**.

**Example – Remaining setpoint for connected Charging stations:**

In the zone described in the example upper, one (1) EVlink Parking T2 has lost the communication with the EcoStruxure EV Charging Expert.

The default setpoint is 9A for each charger of the disconnected EVlink Parking.

For the remaining charging stations of the zone, the maximum current to manage is  $51A - (2 \text{ chargers} * 9A)$ .

So, there is 33A available for the 2 charging stations.

**2.6.4.2 Degraded mode for a dynamic zone**

A Dynamic zone is linked to a Power Meter. **When the communication is lost with the PM**, the EcoStruxure EV Charging Expert manage the zone as a static one with the default setpoint defined by the user.

By default, this setpoint is zero, meaning that the vehicles cannot load when the communication is lost with the PM.

**When the communication is lost with the EcoStruxure EV Charging Expert**, the disconnected charging stations has a setpoint equal to zero (0) A.

For the remaining charging stations that still be connected to the EcoStruxure EV Charging Expert, the maximum current to share is equal to ***the Maximum Intensity set for the Zone.***

### 2.6.4.3 Particular case: DC charging station



Note: The EcoStruxure EV Charging Expert has no control on DC charging station during disconnection. The last setpoint is kept till the reconnection

### 2.6.5 Zone settings

Settings	Access rights		Range	Factory setting	Description
	Admin	User			
Name	R/W	NA		NA	Zone name
Max intensity	R/W	NA		NA	Maximum current available (A) in the selected zone
Power meter	R/W	NA		NA	Power meter assigned to the selected zone
Power management	R/W	NA	Dynamic	NA	Zone supporting dynamic energy management
			Static	NA	Zone supporting static energy management
Authentication mode	R/W	NA		NA	Authentication mode applied in the zone

R/W: Read/Write - NA: Not Available / Not Applicable

## 2.7 Charging stations assignment to zone

This section allows to assign charging station to a zone.

When clicking on a zone in the left navigation tree, you will see charging station already added to the zone in green and charging station which are not yet assigned to a zone in white.

The **FILTERS** button allows to filter charging stations by Name, Box identity, zone, type and Sub network.

The screenshot displays the 'Configuration of stations per zone' interface. On the left, a navigation tree shows the following zones and their counts:

- Not assigned stations: 4
- 1st Floor:
  - 1st Floor - North: 4
  - 1st Floor - South: 8
- 2nd Floor:
  - 2nd Floor - North:
    - 2nd Floor - North-East: 6
    - 2nd Floor - North-West: 6
  - 2nd Floor - South: 11
- 3rd Floor (VIP): 1

The central table lists the following charging stations:

Station Name	IP Address	Station ID
Station 02	192.168.0.2	S02
Station 03	192.168.0.3	S03
Station 04	192.168.0.4	S04
Station 05	192.168.0.5	S05
Station 06	192.168.0.6	S06
Station 07	192.168.0.7	S07
Station 08	192.168.0.8	S08
Station 41 (VIP)	192.168.0.41	S41

Legend for station status:

- The station is already assigned to another zone
- The station is in another sub network or is not connected

To add a charging station to a zone, you must click on the 'white' charging station in the central area.

To remove charging station from a zone, you must click on a 'green' charging station in the central area.

Charging station not yet assigned to a zone are listed in the "Not Assigned stations" in the top section of the left navigation tree.

When all charging station have been assigned, you can save your configuration using the **SAVE ALL** button.

## 2.8 Remote supervision configuration

### 2.8.1 Remote supervision configuration

The remote supervision must be enabled when the customer has chosen to have the installation managed by a CPO (Charge Point Operator). The CPO will provide the installer with a URL. The URL will be used by the charging stations to establish communication between the remote supervision and the charging stations. The communication protocol **must be OCPP 1.6 Json**.

The remote supervision is disabled (OFF) by default. The time and date provided by the web browser are displayed. The EcoStruxure EV Charging Expert allows to configure the time zone.

The screenshot shows the 'Configuration assistant of the EcoStruxure EV Charging Expert' interface. The 'Remote Supervision' step is active. A warning banner at the top says 'Please make sure that the stations are powered on!'. The 'Remote supervision configuration' section has 'Enable' set to 'OFF' (indicated by a red button). The 'Current date / time' is '8/18/2021, 4:04:16 PM' and the 'Time zone' is 'Europe/Paris'. There are 'SAVE', 'PREVIOUS', and 'NEXT' buttons at the bottom.

When the remote supervision is enabled (ON), the time and date are provided by the remote supervision.

The screenshot shows the same configuration page, but 'Enable' is now set to 'ON' (indicated by a green button). The 'Remote supervision URL address' field contains 'ws://URL\_BACKEND'. The 'Current date / time' and 'Time zone' fields are now empty. The 'SAVE', 'PREVIOUS', and 'NEXT' buttons are still present.

When enabled, the remote supervision must be configured with the communication parameters between the remote supervision and the EcoStruxure EV Charging Expert.

The main field to enter is the remote supervision URL address.

Settings	Access rights		Factory setting	Description
	Admin	User		
Address (Supervision URL)	R/W	NA	NA	Remote supervision URL. It shall start with ws:// or wss:// in case of secure mode

R/W: Read/Write - NA: Not Available / Not Applicable

When the installer clicks “Next”, the system will reboot to take into account the new settings. Then the installer needs to log in again to perform the next configuration steps.



Note: If the EcoStruxure EV Charging Expert sub-network (**192.168.0.128**) is changed, the sub-network of the computer must also be changed after the reboot of the EcoStruxure EV Charging Expert.



## 2.9 Load shedding strategy and degraded mode

### 2.9.1 Definition

The degraded mode is a parameter defining the current setpoint allocated to the charging station when the communication between the charging station and the EcoStruxure EV Charging Expert is lost. It is also the threshold under which the charge will be suspended in normal mode.

In dynamic mode, the EcoStruxure EV Charging Expert will favor the continuity of service of the building, therefore the current setpoint will be set by default to 0 A.

However, EcoStruxure EV Charging Expert allows the person in charge of the system configuration to define a degraded mode maximum current setpoint.



It is recommended to ensure that the degraded mode maximum current setpoint defined by the installer is available for EV charging **at all times**. Otherwise there's a risk of power outage in the building.

### 2.9.2 Prerequisites

The sum of the degraded mode setpoint must be lower than the max intensity of the zone. Otherwise, for safety and continuity of service reasons, the **EcoStruxure EV Charging Expert will automatically configure the current setpoint to 0A**

### 2.9.3 Degraded mode configuration page

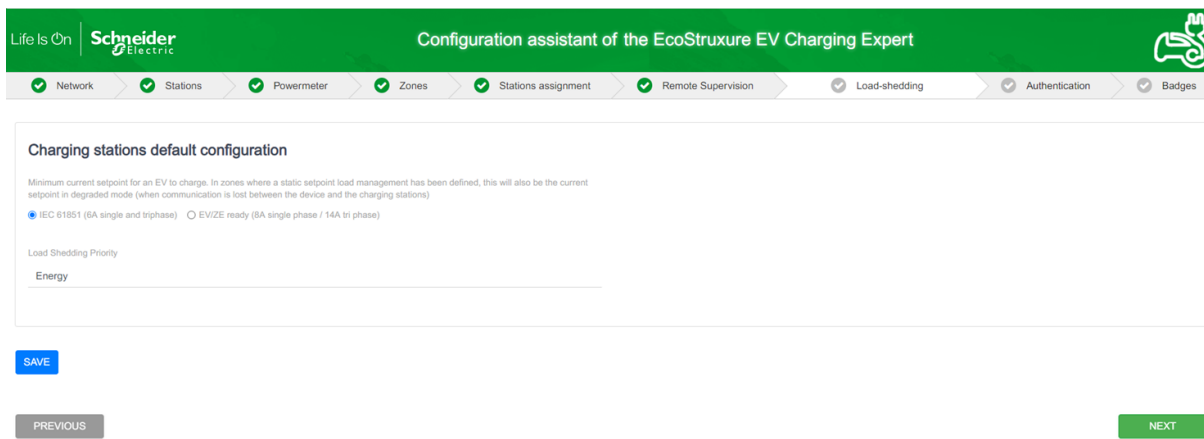

Step	Description
1	Select the minimum current setpoint at which the EVs will accept to charge for your installation <ul style="list-style-type: none"> <li>- IEC 61851 (6A in both single and 3-phase connection)</li> <li>- EV/ZE ready (8A in single-phase, 14A in 3-phase connection)</li> </ul>
2	Please choose the load shedding priority option  > <b>Energy</b> : Proportional to the energy consumed (kWh) <ul style="list-style-type: none"> <li>• The system suspends the charging of vehicles which have consumed the highest amount of energy since the beginning of the charging process. This option is set by default.</li> </ul> > <b>Duration</b> : Proportional to the charging time

Step	Description
	<ul style="list-style-type: none"><li>• The system suspends the charging of vehicles which have charged for the longest time since the beginning of the charging process.</li></ul>
3	Click "Next" to complete the process



Note: DC Fast Charging stations don't support degraded mode. Make sure the electric network is dimensioned and configured taking that into account.

## 2.10 Authentication mode configuration

The authentication mode defines the rules and strategy to grant access to the charging stations. Moreover, it allows to define the behavior of the charging stations in the case that the connection between the charging stations and the EcoStruxure EV Charging Expert is lost.

A different authentication mode can be defined per zone. This is done at the zones configuration tab ([see chapter 2.6](#)).

The screenshot shows the 'Configuration assistant of the EcoStruxure EV Charging Expert' interface. The top navigation bar includes steps: Network, Stations, Power meter, Zones, Stations assignment, Remote Supervision, Load-shedding, Authentication (current), and RFID cards. The main heading is 'Configuration of the user identification and authentication mode to use the charging stations'. Below this, instructions state: 'You are now selecting a generic option as authentication mode for the entire installation. Later, and once you land on the operation dashboard, you will have the possibility to change the authentication mode for the different charging stations:'. Two options are provided: '- For an entire zone (on the "Zones management" tab on the Admin -> Configuration menu)' and '- For each charging station (on the "Stations installation" menu)'. The 'Authentication mode' section has three radio buttons: 'Authorize all RFID cards' (unselected), 'Authorize only the known RFID cards' (selected with a green checkmark), and 'Disable RFID card reader' (unselected). The 'Authentication mode in case of disconnection between the device and the charging stations' section has three radio buttons: 'Authorize all RFID cards' (selected with a green checkmark), 'Reject all RFID cards' (unselected), and 'Use cache' (unselected). A blue 'SAVE' button is centered below these options. At the bottom, there are 'PREVIOUS' and 'NEXT' buttons.

The authentication authorization is managed by the remote supervision if any is configured. In other case EV Charging Expert manages the authentication authorization. In the next section, we will call *SUPERVISOR* the remote supervision or EV Charging Expert.

The possible options of authentication are:

**“Authorize all RFID cards”**: The *SUPERVISOR* will allow any RFID card to charge. The same behavior is expected on each charging station when the connection is lost. This option requires the charging stations to be equipped with an RFID reader.

**“Authorize only the known RFID cards”**. Only the RFID cards created in the *SUPERVISOR* system are allowed. When a RFID card is scanned at a charging station, it will get permission to charge or not based on whether it is included or not in the list hosted in the *SUPERVISOR*. This is the default option.

When the connection is lost with the *SUPERVISOR*, the behavior options to choose from are:

- **“Authorize all RFID cards”**: All requests to charge are accepted by the charging stations whatever the RFID card
- **“Reject all RFID cards”**: All requests to charge are refused by the charging stations whatever the RFID card
- **“Use cache”**: Requests to charge coming from RFID cards already used on the specific charging station will be accepted.

**“Disable RFID card reader”**: The RFID reader is disabled. When this option is selected, there is no authentication mode and hence, to charge, the user only needs to connect the plug

When the required option(s) are selected, click the “Next” button.

## 2.11 RFID card management

This is the last step in the configuration wizard. The same interface is included in the EcoStruxure EV Charging Expert Dashboard, RFID cards tab. If the authentication mode has been set to “EcoStruxure EV Charging Expert– Allow only the known RFID cards”, the list of authorized RFID cards must be entered here.

If a remote supervision has been configured, this step has to be skipped.

### 2.11.1 Prerequisites

Beforehand the authentication mode must have been set to “**Authorize only the known RFID cards**”. Otherwise, you can skip this step.

### 2.11.2 RFID card management configuration page

### 2.11.3 RFID card addition

#### 2.11.3.1 RFID card manual addition

Step	Description
1	Click the “Add a RFID card” button.
2	Enter the IdTag of the RFID card NOTE: to know the IdTag, use a dedicated smartphone app or other device
3	Select the status: <ul style="list-style-type: none"> <li>- <b>VIP</b> (otherwise, standard RFID card): Select this option to provide the RFID card with VIP privileges. This option is available <b>only in specific EcoStruxure EV Charging Expert references</b> (refer to <a href="#">chapter 1.1.1.3</a>).and <b>only with EcoStruxure EV Charging Expert authentication selected</b> (refer to <a href="#">chapter 2.10</a>).</li> <li>- <b>Authorized</b>: Select this option to authorize the RFID card to charge.</li> </ul>
4	Enter comments (example, name of the owner of the RFID card, 50 characters max).

5	Select the zone where the RFID card is allowed
6	Click the “check” button located at the end of the RFID card line.

### 2.11.3.2 RFID card list import



**Note: if the installer imports a list of RFID cards, all previously registered RFID cards will be deleted**

If the RFID card list is already available:

Step	Description
1	Click the “IMPORT” button on the EcoStruxure EV Charging Expert RFID card configuration page..
2	Select the import file format: EcoStruxure EV Charging Expert or charging station. <b><i>The file format of the EcoStruxure EV Charging Expert and the charging station are different. The charging station file is compatible with the EcoStruxure EV Charging Expert but not the reverse.</i></b>
3	Click Confirm.

If the RFID card list is not yet available and needs to be created:

Step	Description
1	Swipe all RFID cards to be imported into the EcoStruxure EV Charging Expert in front of the RFID card reader of a charging station connected to the EcoStruxure EV Charging Expert.
2	Export the RFID card list from the charging station (see DOCA0060EN)
3	Click the IMPORT button on the EcoStruxure EV Charging Expert RFID card configuration page and import the file with the RFID card list from your computer
4	Confirm.

This last procedure is the most efficient way to add a large group of new RFID cards to the EcoStruxure EV Charging Expert.

### 2.11.4 RFID card file export

The export feature is used to back up the RFID card list in the EcoStruxure EV Charging Expert format.

### 2.11.5 RFID card removal

Select the red button located on the right-hand side of each RFID card line to remove the RFID card from the list.

### 2.11.6 RFID card update

The following fields can be updated:

- Authorization
- Type (VIP, or Standard by unselecting VIP) (available on specific EcoStruxure EV Charging Expert commercial references, see [chapter 1.1.1.3.](#))
- Comments
- Zones

### 2.11.7 Bulk modification

If you want to update multiple RFID cards at the same time, you can use the “bulk modifications” functionality. To do so:

1. Click on the “bulk modification” button.
2. Select the RFID cards you want to update
3. Select the values you want for VIP, Authorized and zones
4. Click on the “Save” button

### 2.11.8 RFID cards filters

You can filter RFID cards by IdTag, comments, zones, VIP and authorized

# Chapter 3.

# OPERATION

# INTERFACE

## 3.1 Login to the EcoStruxure EV Charging Expert (Webserver)

Step	Action
1	Prerequisite: Wizard process completed Open a web browser (Google Chrome) and enter 192.168.0.128 (default address) or the address defined during the commissioning.
2	Log in with credentials defined for Admin profile during the commissioning



## 3.2 Menu and status bar

### 3.2.1 Bar items



Mark	Description
1	EcoStruxure EV Charging Expert contextual menu
2	Number of charging stations per status: green – available, blue – charging in progress, red – malfunctioning
3	Language selection (English, French, German or Spanish)
4	Logout
5	Commissioning assistant restart button
6	Display of EcoStruxure EV Charging Expert firmware version
7	Access to download the user guide



## 3.3 Dashboard

### Access by the Charging Stations tab

#### 3.3.1 Global view

The purpose of this tab is to display the ongoing status of the charging stations and the load transactions managed by the EcoStruxure EV Charging Expert.

Moreover, some specific actions can be executed on connected charging stations.

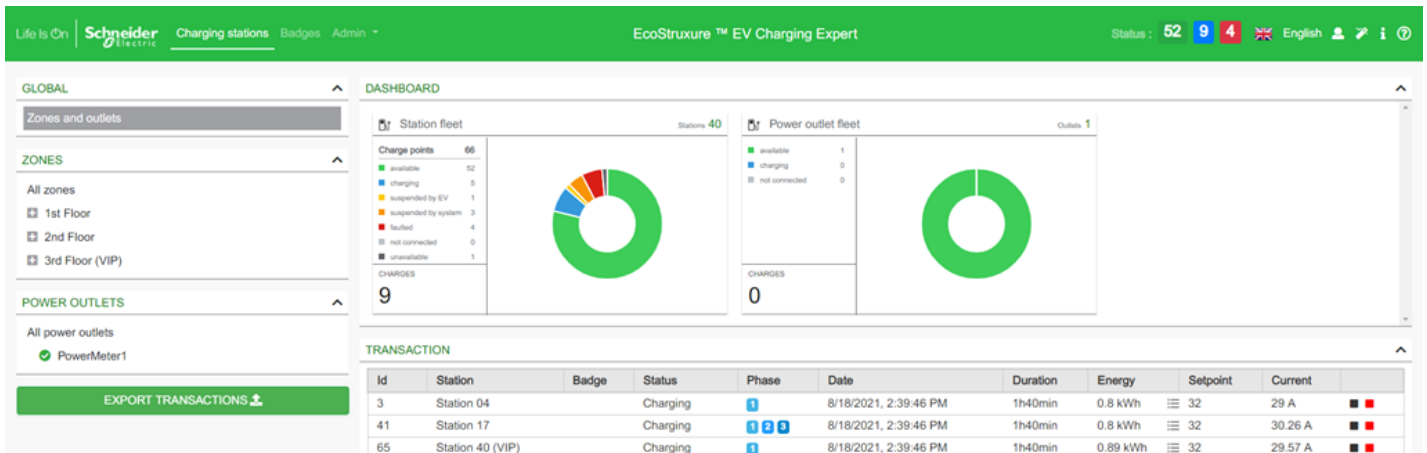

The global view is made up of three parts:

#### EcoStruxure EV Charging Expert topology

On the left, the EcoStruxure EV Charging Expert topology is displayed. It is composed of zone organization, power outlets (other loads than charging stations for which we want to monitor the consumption) - each part can be selected, then expanded or collapsed to display or hide details.

#### Station Fleet

In station fleet, the status of charging stations is displayed. The different status are:

- **Available:** when the connector of the charging station is available
- **Charging:** when a transaction is in progress on this connector
- **Suspended by EV:** when the transaction is suspended by the vehicle.
- **Suspended by EcoStruxure EV Charging Expert:** when the charging station or the EcoStruxure EV Charging Expert suspend the transaction to meet Energy requirements : either because the available energy limit is reached or because some stations don't respect the setpoint.
- **Faulted:** when there was an error during the transaction
- **Disconnected:** when the charging station related to this connector is disconnected from the EcoStruxure EV Charging Expert

#### Power outlet Fleet

The status of all power outlets ( power meter having reporting type, others electrical equipments, ...) is displayed:



- **Available:** the power outlets are available

- **Charging:** when the power meters detect some consumption, or the electrical equipments are consuming.
- **Disconnected:** when the power outlets are disconnected

## Transaction

At the bottom, the ongoing charging sessions are displayed. The user can remotely stop the charging session.

### Actions

Icon	Description
	Stop transaction: remotely stop the selected charging session(s)
	Force Stop transaction: force the EcoStruxure EV Charging Expert to stop a transaction

**EXPORT TRANSACTIONS button:** Click here to export the charging data records for the transactions done on all charging stations in the network since the commissioning of the EcoStruxure EV Charging Expert.

The charging data records are exported to an external file in CSV format for all the charging stations.

It is possible to select the period before exporting the file.

The exported data are the following:

- Transaction number
- Charging station ID
- Socket outlet
- User ID
- Type of charge
- Start datetime
- End datetime
- Energy consumed (kWh)
- Socket type
- Transaction duration
- Comment
- Charge box identity
- Station name
- Effective charge duration
- NoPeriod: Energy consumed (kWh) during the transaction outside of any defined time-of-use period and timeslots.

There may be additional columns for each and every time-of-use tariff period available at the time of the export. Each additional column is named after the corresponding period name and the values shown correspond to the energy in kWh consumed within the transaction during the specific period.

See Time-of-use (TOU) documentation at [chapter 3.10.3](#) for more details about time-of-use tariff periods.

### 3.3.2 Zone view

Zone view is available when a zone is selected in the left panel.

The zone view provides the same data as the global view plus the capability for the user to manage the charging stations.

The screenshot shows the 'Zone view' for the '2nd Floor' zone. The interface includes a left sidebar with navigation options for 'ZONES' and 'POWER OUTLETS'. The main dashboard displays the following information:

- Station fleet:** 23 stations. Charge points: 32 available, 3 charging, 1 suspended by EV, 1 suspended by system, 2 faulted, 0 not connected, 0 unavailable.
- Cluster power repartition:** Report 400 A. L1: 92 A / 400, L2: 32 A / 400, L3: 64 A / 400.
- STATIONS Table:**









Name	Zone	Connector	Status	Phase
Station 17	2nd Floor - North-East	1	charging	TRI123
Station 18	2nd Floor - North-East	2	available	MONO3
Station 19	2nd Floor - North-East	1	available	TRI231
Station 20	2nd Floor - North-East	2	available	MONO2
Station 21	2nd Floor - North-East	1	available	TRI123
Station 22	2nd Floor - North-East	1	available	TRI312
Station 23	2nd Floor - North-West	1	charging	TRI312
		2	available	MONO1

The screenshot shows the 'Zone view' for the '3rd Floor (VIP)' zone. The interface displays the following information:

- Station fleet:** 2 stations. Charge points: 1 available, 1 charging, 0 suspended by EV, 0 suspended by system, 0 faulted, 0 not connected, 0 unavailable.
- Cluster power repartition:** Report 200 A. L1: 32 A / 200, L2: 0 A / 200, L3: 0 A / 200.
- Power meter:** PowerMeter2. Energy (kWh): 1.2, Power (kW): 0. L1: 116 / 200, L2: 100 / 200, L3: 100 / 200.
- STATIONS Table:**

Name	Zone	Connector	Status	Phase
Station 40 (VIP)	3rd Floor (VIP)	1	charging	TRI312
Station 41 (VIP)	3rd Floor (VIP)	1	available	TRI123

## Actions

Icon	Description
	Create a Maintenance Report for the charging station. This report could then be downloaded from Admin > Stations Report
	Update a charging station (details in next part)
	Start a session: remotely start a charging session on the selected charge point
	Connect to a charging station web server
	Reboot a charging station
	Remove a charging station from the EcoStruxure EV Charging Expert
	Stop a session: remotely stop a charging session / transaction on the selected charge point
	Force Stop transaction: force the EcoStruxure EV Charging Expert to stop a charging session / transaction <i>(just needed in the particular case of the EcoStruxure EV Charging Expert losing connection to the charging station during the transaction, and control to stop the fictive transaction remaining is needed).</i>
	Status of the connection devices

### Cluster energy repartition supervision

On the EcoStruxure EV Charging Expert Dashboard, the user can supervise the energy repartition on each phasis for a zone.

On a zone, the sum of setpoint given for active charging stations transactions is displayed. When a station is disconnected, the EcoStruxure EV Charging Expert consider that it is consuming with a degraded setpoint (see [chapter 2.6.4](#) for degraded mode)

### Power meter

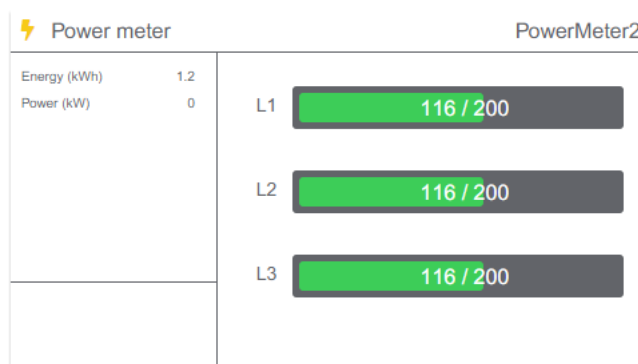

The power meter tab displays the real consumption measured by the PM, for each phasis. This consumption concerns:

- The charging stations affected to the dynamic zone
- The others electric equipment's physically connected to the power meter

### 3.3.3 Charging station view

The charging station view is available when a charging station is selected in the left panel or by the charging station update icon in the bottom panel.

STATION 29(S29)

Name \* Station 29

Box Identity \* S29

VIP

Auth Mode RFID disabled

Auth Disconnected Mode Allow all

Register Cancel

In case of EVlink Smart Wallbox, City and Parking, the following changes can be done:

- Charging station name
- Charging station Box Identity
- If available, charging station type status: VIP or standard
- Authentication mode
- Authentication behavior when Charging station is disconnected

### 3.3.4 Charging station view – EVlink Pro AC firmware update

In case of EVlink Pro AC, a manual remote update from EV Charging Expert is possible per each EVlink Pro AC charging station:

EVLINK PRO AC - 20220([EVLINK PRO AC METAL] - [20220])

Name \* EVlink Pro AC - 20220

Charge Box Identity \* [EVlink Pro AC Metal] - [20220]

VIP

Authentication Mode Disable RFID card reader

Authentication When Disconnected Authorize all RFID cards

Firmware ⓘ 01.00.00

UPDATE FIRMWARE ( 1.0.1.5 )

UPLOAD A NEW FIRMWARE VERSION

- Click on **“UPLOAD A NEW FIRMWARE VERSION”** to upload the latest EVlink Pro AC firmware from your computer in EV Charging Expert

EVLINK PRO AC - 20220([EVLINK PRO AC METAL] - [20220])

Name \* EVlink Pro AC - 20220

Charge Box Identity \* [EVlink Pro AC Metal] - [20220]

VIP

Authentication Mode Disable RFID card reader

Authentication When Disconnected Authorize all RFID cards

Firmware ⓘ 01.00.00

UPDATE FIRMWARE ( 1.0.1.5 )

UPLOAD A NEW FIRMWARE VERSION

- Then Click on **“UPDATE FIRMWARE (x.x.x.x)”** to update the EVlink Pro AC with the latest firmware version

# 3.4 RFID card management

The same interface as in the configuration assistant is included in the EcoStruxure EV Charging Expert Dashboard, RFID cards tab. If the authentication mode has been set to “EcoStruxure EV Charging Expert– Authorize only the known RFID cards”, the list of authorized RFID cards must be entered here.

## 3.4.1 Prerequisites

Beforehand the authentication mode must have been set to “EcoStruxure EV Charging Expert– Authorize only the known RFID cards”. Otherwise, you can skip this step.

## 3.4.2 RFID card management configuration page

IdTag	VIP	Authorized	Comments	Registration	Last time seen	Zones
EFR41DEZ	<input checked="" type="checkbox"/>	<input checked="" type="checkbox"/>	VIP	03/09/2020	03/09/2020	3rd Floor (VIP)
BN17TM56	<input checked="" type="checkbox"/>	<input checked="" type="checkbox"/>	VIP	03/09/2020	03/09/2020	3rd Floor (VIP)
PM4554ER	<input type="checkbox"/>	<input checked="" type="checkbox"/>		03/09/2020	03/09/2020	All zones
NBE44DZ5	<input type="checkbox"/>	<input checked="" type="checkbox"/>		03/09/2020	03/09/2020	All zones
D6EFC4RB	<input type="checkbox"/>	<input checked="" type="checkbox"/>		03/09/2020	03/09/2020	All zones

## 3.4.3 RFID card addition

### 3.4.3.1 RFID card swipe

Step	Description
1	Swipe the RFID card in front of the RFID card reader of a charging station connected to the EcoStruxure EV Charging Expert.
2	Click the Refresh button on the EcoStruxure EV Charging Expert RFID card configuration page.
3	Select the status: <ul style="list-style-type: none"> <li>- <b>VIP</b> (otherwise, standard RFID card): Select this option to provide the RFID card with VIP privileges. This option is available <b>only in specific EcoStruxure EV Charging Expert commercial references</b> (refer to <a href="#">chapter 1.1.1.3</a>) <b>and only with EcoStruxure EV Charging Expert authentication selected</b> (refer to <a href="#">chapter 2.10</a>).</li> <li>- <b>Authorized</b>: Select this option to authorize the RFID card to charge.</li> </ul>
4	Enter comments (50 characters max)
5	Click the “SAVE ALL” button

### 3.4.3.2 RFID card manual addition

IdTag	VIP	Authorized	Comments	Registration	Last time seen	Zones
<input type="text"/>	<input type="checkbox"/>	<input checked="" type="checkbox"/>	<input type="text"/>	<input type="text"/>	<input type="text"/>	All zones

Step	Description
1	Click the “Add a RFID card” button.

2	Enter the IdTag of the RFID card NOTE: to know the IdTag, use a dedicated smartphone app or other device
3	Select the status: <ul style="list-style-type: none"> <li>- <b>VIP</b> (otherwise, standard RFID card): Select this option to provide the RFID card with VIP privileges. This option is available <b>only in specific EcoStruxure EV Charging Expert references</b> (refer to <a href="#">chapter 1.1.1.3</a>) <b>and only with EcoStruxure EV Charging Expert authentication selected</b> (refer to <a href="#">chapter 2.10</a>).</li> <li>- Authorized: Select this option to authorize the RFID card to charge.</li> </ul>
4	Enter comments (example, name of the owner of the RFID card, 50 characters max).
5	Select the zones where the RFID card will be allowed
6	Click on the "SAVE ALL" button

### 3.4.3.3 RFID card list import



**Note: if the installer imports a list of RFID cards, all previously registered RFID cards will be deleted**

If the RFID cards list is already available:

Step	Description
1	Click the "IMPORT" button on the EcoStruxure EV Charging Expert RFID card configuration page..
2	Select the import file format: EcoStruxure EV Charging Expert or charging station. <b><i>The file format of the EcoStruxure EV Charging Expert and the charging station are different. The charging station file is compatible with the EcoStruxure EV Charging Expert but not the reverse.</i></b>
3	Click on Confirm.

If the RFID cards list is not yet available and needs to be created:

Step	Description
1	Swipe all RFID cards to be imported into the EcoStruxure EV Charging Expert in front of the RFID card reader of a charging station connected to the EcoStruxure EV Charging Expert.
2	Export the RFID card list from the charging station (see DOCA0060EN)
3	Click on the IMPORT button on the EcoStruxure EV Charging Expert RFID card configuration page and import the file with the RFID card list from your computer
4	Confirm.

This last procedure is the most efficient way to add a large group of new RFID cards to the EcoStruxure EV Charging Expert.

### 3.4.4 RFID card file export

The export feature is used to back up the RFID card list in the EcoStruxure EV Charging Expert format.

### 3.4.5 RFID card removal

Select the red button located on the right-hand side of each RFID card line to remove the RFID card from the list.

### 3.4.6 RFID card update

The following fields can be updated:

- Authorization
- Type (VIP, or Standard by unselecting VIP). This option is available **only in specific EcoStruxure EV Charging Expert commercial references** (refer to [chapter 1.1.1.3](#)).and **only with EcoStruxure EV Charging Expert authentication selected** (refer to [chapter 3.7.6](#)).
- Comments

### 3.4.7 Bulk Modification

RFID cards management 
[ADD AN RFID CARD +](#)
[IMPORT](#)
[EXPORT](#)
[BULK MODIFICATIONS +](#)
[FILTERS](#)
[SAVE ALL](#)

VIP: Yes  Authorized: Yes  Zones: 
[CANCEL](#) [SAVE](#)

<input type="checkbox"/>	IdTag^	VIP	Authorized	Comments	Registration*	Last time seen^	Zones	
<input checked="" type="checkbox"/>	EFR41DEZ	<input checked="" type="checkbox"/>	<input checked="" type="checkbox"/>	<input type="text" value="VIP"/>	03/09/2020	03/09/2020	3rd Floor (VIP)	<input type="checkbox"/>
<input type="checkbox"/>	BN17TM56	<input checked="" type="checkbox"/>	<input checked="" type="checkbox"/>	<input type="text" value="VIP"/>	03/09/2020	03/09/2020	3rd Floor (VIP)	<input type="checkbox"/>
<input checked="" type="checkbox"/>	PM4554ER	<input type="checkbox"/>	<input checked="" type="checkbox"/>	<input type="text"/>	03/09/2020	03/09/2020	All zones	<input type="checkbox"/>

Step	Description
1	Click the "Bulk Modifications" button, then a menu is proposed to choose wanted changes.
2	Select the RFID cards to modify
3	Select the VIP status: <ul style="list-style-type: none"> <li>- <b>Yes:</b> to provide the RFID cards with VIP privileges. This option is available <b>only in specific EcoStruxure EV Charging Expert references</b> (refer to <a href="#">chapter 1.1.1.3</a>).and <b>only with EcoStruxure EV Charging Expert authentication selected</b> (refer to <a href="#">chapter 2.10</a>).</li> <li>- <b>No:</b> the RFID cards are standard ones.</li> </ul>
4	Select the Authorization status: <ul style="list-style-type: none"> <li>- <b>Yes:</b> to authorize the RFID cards to charge</li> <li>- <b>No:</b> to disallow the RFID cards to charge</li> </ul>
5	Select the zones where the RFID cards are allowed. One or several zones can be selected.
6	Click the "SAVE ALL" button



# 3.5 Network configuration

Access by the Admin tab → Configuration → Network



Note: Whatever the parameters changed in network configuration, a reboot must be done after the configuration.

### Device name

Name

### Network configuration i

IP address  .  .  .

Sub network mask  .  .  .

Default gateway  .  .  .

Preferred dns system  .  .  .

Other dns system  .  .  .

### Proxy configuration

Activate proxy support  ON  OFF

### DHCP server configuration i

Activate the DHCP server  ON  OFF

## 3.5.1 Ethernet configuration

Consult [chapter 2.3.1 Ethernet Configuration](#).

## 3.5.2 Proxy configuration

**Proxy:** A proxy server is a dedicated computer or a software system running on a computer that acts as an intermediary between an endpoint device, such as a computer, and another server from which a user or client is requesting a service.



Note: Must be activated if required by network installation

Settings	Access rights		Factory setting	Description
	Admin	User		
Proxy address	R/W	NA		Proxy server IP address (1)
Proxy port	R/W	NA	80	Proxy server port used (1)

R/W: Read/Write - NA: Not Available  
(1) Available only with Proxy support activated

## 3.5.3 DHCP server configuration

Consult chapter 2.3.3 DHCP server configuration.

## 3.6 Remote supervision configuration

Access by the Admin tab → configuration → remote supervision



Note: Whatever the parameters changed in supervision configuration, a reboot must be done after the configuration.

### 3.6.1 Remote supervision configuration

The remote supervision must be enabled when the customer has chosen to have the installation managed by a CPO (Charge Point Operator). The CPO will provide the installer with a URL. The URL will be used by the charging stations to establish communication between the remote supervision and the charging stations. The communication protocol **must be OCPP 1.6 Json**.

The remote supervision is disabled (OFF) by default. The time and date provided by the web browser are displayed.

Remote supervision configuration

Enable  ON  OFF

Current Date/Time **Thu Mar 21 2019 15:55:45 GMT+0100**

Remote supervision configuration

Enable  ON  OFF

Remote supervision URL address

TransactionMessageAttempts

WebSocketPingInterval

When the remote supervision is enabled (ON), the time and date are provided by the remote supervision

The remote supervision must be configured with the communication parameters between the remote supervision and the EcoStruxure EV Charging Expert.

The main field to enter is the CPO supervision URL address. The other fields are parameters used by OCPP experts. The installer can choose to leave the default values. The CPO will change them afterwards if needed.

Settings	Access rights		Factory setting	Description
	Admin	User		
Supervision URL	R/W	NA		Remote supervision URL; Start with ws:// or wss:// in case of secure mode
TransactionMessageAttempts	R/W	NA	500	Maximum message sending attempts before drop
WebSocketPingInterval	R/W	NA	120 sec	Web socket ping interval

R/W: Read/Write - NA: Not Available

## 3.7 Zone configuration

Access by the Admin tab → configuration → zone management



Note: Any parameter change in zones configuration (with the exception of a change limited to Max Intensity), requires a reboot after the configuration.

### 3.7.1 Prerequisites

Reminder: Power meters are only required in EcoStruxure EV Charging Expert dynamic mode. Their Ethernet connection must be configured regardless of the EcoStruxure EV Charging Expert and prior to the EcoStruxure EV Charging Expert commissioning.

### 3.7.2 Zone landing page

Zone creation Your limit for the creation of zones : 20

Name	Max intensity	Energy management directive	Power meter	Authentication mode	
+ 1st Floor	200	Static			✓
+ ↙ 1st Floor - North	150	Static		Allow all badges	✓
+ ↘ 1st Floor - South	150	Static		Allow all badges	✓
+ 2nd Floor	400	Static			✓
+ ↙ 2nd Floor - North	250	Static			✓

EcoStruxure EV Charging Expert can manage different zones and subzones based on the electrical architecture deployed in the installation. Please refer to [chapter 1.4](#).

The zone landing page allows the installer to define:

- the name of each zone and its sub-zones,
- its maximum current setpoint (maximum intensity),
- the energy management mode for the zone,
- the power meter to associate to the zone if the management mode is dynamic,
- the authentication mode.

The [ADD A ROOT ZONE](#) button allow to add a new zone at the root level.

Icon	Access rights		Description
	Admin	User	
	Yes	No	Add a new zone
	Yes	No	Save the zone configuration
	Yes	No	Delete a zone

### 3.7.3 Description

Step	comments
1	Click <b>+</b> next to <b>Name</b> to create a zone. Several zones can be created depending on the EcoStruxure EV Charging Expert reference.
2	Click <b>+</b> next to <b>Zone</b> to create a sub-zone. Several sub-zones can be created depending on the EcoStruxure EV Charging Expert reference.
3	Set the maximum intensity allowed in each zone and sub-zone. <b>Note:</b> <ul style="list-style-type: none"> <li>- <b>The value must be lower or equal to the electrical capacity of the installation.</b></li> <li>- <b>Max intensity in a sub-zone cannot be higher than the maximum intensity in the related zone.</b></li> </ul>
4	By default the new zone is in <b>Static</b> mode. Select a power meter to put it in <b>Dynamic</b> mode. The power meter measures the zone current. It is assigned to a single zone and cannot be shared.  Static mode: The maximum power setpoint value for the charging stations is equal to the subscribed demand or any fixed value.  Dynamic mode: The remaining power at the building level is allocated to the charging infrastructure in real time.
5	For the dynamic zone, set a <b>Default Setpoint</b> to be used when the communication is lost with the PM (see <a href="#">chapter 2.6.4.2</a> )  
6	Select an authentication mode for the zone.

### 3.7.4 Degraded mode

The degraded mode is described in [chapter 2.6.4](#).

### 3.7.5 Zone settings

Settings	Access rights		Range	Factory setting	Description
	Admin	User			
Name	R/W	NA			Zone name
Max intensity	R/W	NA			Maximum current available (A) in the selected zone
Power meter	R/W	NA			Power meter assigned to the selected zone
Power management	R/W	NA	Dynamic		Zone supporting dynamic energy management
			Static		Zone supporting static energy management
Authentication mode	R/W	NA		NA	Authentication mode applied in the zone

R/W: Read/Write - NA: Not Available

### 3.7.6 Authentication mode by zone

**Zone creation** Your limit for the creation of zones : 20

Name	Max intensity	Energy management directive	Power meter	Authentication mode
+ 1st Floor	200	Static		
+ ↩ 1st Floor - North	150	Static		Authorize all RFID cards
+ ↩ 1st Floor - South	150	Static		Authorize all RFID cards
+ 2nd Floor	400	Static		
+ ↩ 2nd Floor - North	250	Static		
+ ↩ 2nd Floor - North-East	150	Static		Authorize all RFID cards
+ ↩ 2nd Floor - North-West	150	Static		Authorize all RFID cards
+ ↩ 2nd Floor - South	250	Static		Authorize all RFID cards
+ 3rd Floor (VIP)	200	Dynamic	Degraded mode zone setpoint: 100	PowerMeter3 Authorize only the known RFID car

+

The authentication mode can be defined for an entire zone. It is propagated by default to all charging stations of the zone. To start a load, the authentication mode registered on the charging station is taken into account. This one can be modified individually on dashboard (see [chapter 3.3.3](#)) or during installation (see [chapter 3.14.5](#)).

The authentication modes are described in [chapter 2.10 Authentication mode configuration](#).

## 3.8 Power meter configuration

Access by Admin tab → configuration → Power meters

Consult [chapter 2.5 Power Meter Configuration](#) to know what the prerequisites are, and to know how to configure power meters and their settings.

## 3.9 Time-of-use (TOU)

Access: Admin tab → Configuration → Time-of-use

### 3.9.1 Definition

The time-of-use (TOU) feature allows to define a reduced maximum current setpoint during the times of the day when electricity is more expensive, when the building is under time-of-use type of electricity tariffs. In this way, EV charging can be maximized when electricity has a lower price, and limited when it has a higher price, based on the settings defined by the operator.

A total of 5 tariff periods can be defined, and a total of 20 timeslots can be defined and associated to those tariff periods. You can define TOU period characteristics and then choose to deactivate them if you want to temporarily cancel them, but you don't wish to lose their settings.

TOU feature setup and visualization is only available for the Admin profile.



Note: the TOU configuration is not taken account when the Digital Input functionality is activated

### 3.9.2 Prerequisites

- This feature is available for commercial references HMIBSCEA53D1ESM, -EDS, -EDM and -EDL.
- At least 1 zone must be created (please refer to [chapter 3.7 Zone configuration](#))

### 3.9.3 Tariff period configuration tab

#### 3.9.3.1 Create periods

Define the % of maximum setpoint reduction required per TOU period.

For example: for a zone with a maximum setpoint of 100A, if 80% is defined, the new maximum setpoint will be 80A.

- For Dynamic load management, the maximum setpoint applied will be the lower of the two:
  - the % of reduction defined, or
  - the dynamic current available in real time
- For Static load management, the % of reduction defined will apply

The user can create several periods using the “+” symbol on the screen.

Network Remote supervision Load-shedding Zone management Power meters Time-of-use Digital Input Advanced

**Time-of-use configuration**  [Periods configuration](#) [Zone where periods apply](#) [Summary](#)

Define the time-of-use periods, their applicable timeslots and the % of reduction on maximum current setpoint to apply

Period name	Timeslots	Days	Maximum setpoint	Edit/Remove																				
<span style="display: inline-block; width: 15px; height: 10px; background-color: #4CAF50; margin-right: 5px;"></span> on-peak	<table border="1"> <tr> <th>Start time</th> <th>End time</th> </tr> <tr> <td>08h00</td> <td>12h00</td> </tr> <tr> <td>14h00</td> <td>19h30</td> </tr> </table>	Start time	End time	08h00	12h00	14h00	19h30	<table border="1"> <tr> <th>Monday</th> <th>Tuesday</th> <th>Wednesday</th> <th>Thursday</th> <th>Friday</th> <th>Saturday</th> <th>Sunday</th> </tr> <tr> <td>✓</td> <td>✓</td> <td>✓</td> <td>✓</td> <td>✓</td> <td></td> <td></td> </tr> </table>	Monday	Tuesday	Wednesday	Thursday	Friday	Saturday	Sunday	✓	✓	✓	✓	✓			90 %	
Start time	End time																							
08h00	12h00																							
14h00	19h30																							
Monday	Tuesday	Wednesday	Thursday	Friday	Saturday	Sunday																		
✓	✓	✓	✓	✓																				
<span style="display: inline-block; width: 15px; height: 10px; background-color: #4CAF50; margin-right: 5px;"></span> off-peak	<table border="1"> <tr> <th>Start time</th> <th>End time</th> </tr> <tr> <td>12h00</td> <td>14h00</td> </tr> </table>	Start time	End time	12h00	14h00	<table border="1"> <tr> <th>Monday</th> <th>Tuesday</th> <th>Wednesday</th> <th>Thursday</th> <th>Friday</th> <th>Saturday</th> <th>Sunday</th> </tr> <tr> <td>✓</td> <td>✓</td> <td>✓</td> <td>✓</td> <td>✓</td> <td></td> <td></td> </tr> </table>	Monday	Tuesday	Wednesday	Thursday	Friday	Saturday	Sunday	✓	✓	✓	✓	✓			0 %			
Start time	End time																							
12h00	14h00																							
Monday	Tuesday	Wednesday	Thursday	Friday	Saturday	Sunday																		
✓	✓	✓	✓	✓																				

Five steps are needed to create a period:

step	comments
1	Click on <b>+</b> icon to create a tariff period. Several periods up to 5 can be created
2	Enter period <b>Name</b>
3	Define <b>Timeslots</b> : min 1, max 20 by clicking on 'Add a timeslot' link
4	Define application week <b>day</b> . At least 1 day must be selected.
5	Define % of <b>Maximum setpoint</b> reduction

Period name

Period 2

Timeslots

Start time	End time
4 h 30 m	10 h 0 m

[Add a timeslot](#)

Days

Monday	Tuesday	Wednesday	Thursday	Friday	Saturday	Sunday
	✓		✓			

Maximum setpoint

60 %

Create
Cancel

For the remaining time slots of the day that are not aligned to any tariff period, no reduction of current setpoint will be applied. Nominal current setpoint per zone will apply.



### 3.9.3.2 Description

Settings	Access rights		Range	Factory setting	Description
	Admin	User			
Name	R/W	NA			Tariff period name
Timeslots	R/W	NA	0 - 23 for hours  0-59 for minutes		The tariff period is active only within defined time slots.  - 1 min per period  - 20 max across all periods
Days	R/W	NA			The tariff period is active every week on the selected days.  At least 1 day per period needs to be selected.
Maximum setpoint	R/W	NA	0 - 100		% of reduction to apply to the maximum current setpoint





R/W: Read/Write - NA: Not Available

### 3.9.3.3 Update period

You can update the characteristics of a tariff period by clicking the corresponding Edit button.

Time-of-use configuration

Setup Zone configuration Summary

Period name	Timeslots	Days	Maximum setpoint	Edit/Remove
PERIOD 1	Start time: 10h30, End time: 12h00	Monday, Tuesday	80 %	 
PERIOD 2	Start time: 04h30, End time: 20h00 20h00, 22h20	Monday, Tuesday, Thursday, Friday	60 %	 

Period name: PERIOD 2

Timeslots:

Start time	End time
4 h 30 m	10 h 0 m
20 h 0 m	22 h 20 m

[Add a timeslot](#)

Days:

Monday	Tuesday	Wednesday	Thursday	Friday	Saturday	Sunday
	✓		✓	✓		





Maximum setpoint: 60 %

Update Cancel

### 3.9.3.4 Remove a period

You can remove a tariff period by clicking the corresponding Delete button.

Time-of-use configuration   Setup [Zone configuration](#) [Summary](#)

Period name	Timeslots	Days	Maximum setpoint	Edit/Remove
PERIOD 1	Start time: 10:30, End time: 12:00	Monday ✓, Tuesday ✓, Wednesday, Thursday, Friday, Saturday, Sunday	80 %	 
PERIOD 2	Start time: 04:30, End time: 10:00 20:00, 22:20	Monday, Tuesday ✓, Wednesday, Thursday ✓, Friday ✓, Saturday, Sunday	60 %	 

The period will be removed

### 3.9.4 Zone configuration tab

Define the parking zones where you require all or part of the defined TOU periods to apply. By default, all defined TOU periods apply to all zones but the EcoStruxure EV Charging Expert allows you to modify that.

Time-of-use configuration   [Periods configuration](#) [Zone where periods apply](#) [Summary](#)

Select the parking zones where the different periods apply

Zone	All periods	on-peak	off-peak
1st Floor			
↳ 1st Floor - North	<input checked="" type="checkbox"/>	<input checked="" type="checkbox"/>	<input checked="" type="checkbox"/>
↳ 1st Floor - South	<input checked="" type="checkbox"/>	<input checked="" type="checkbox"/>	<input checked="" type="checkbox"/>
2nd Floor			
↳ 2nd Floor - North	<input checked="" type="checkbox"/>	<input checked="" type="checkbox"/>	<input checked="" type="checkbox"/>
↳ 2nd Floor - North East	<input checked="" type="checkbox"/>	<input checked="" type="checkbox"/>	<input checked="" type="checkbox"/>

You can disable some or all periods for each zone.

Time-of-use configuration   [Periods configuration](#) [Zone where periods apply](#) [Summary](#)

Select the parking zones where the different periods apply

Zone	All periods	on-peak	off-peak
1st Floor			
↳ 1st Floor - North	<input type="checkbox"/>	<input checked="" type="checkbox"/>	<input type="checkbox"/>
↳ 1st Floor - South	<input type="checkbox"/>	<input checked="" type="checkbox"/>	<input checked="" type="checkbox"/>
2nd Floor			
↳ 2nd Floor - North	<input checked="" type="checkbox"/>	<input checked="" type="checkbox"/>	<input checked="" type="checkbox"/>
↳ 2nd Floor - North East	<input checked="" type="checkbox"/>	<input checked="" type="checkbox"/>	<input checked="" type="checkbox"/>

### 3.9.5 Summary tab

On the “Summary” tab, verify the resulting TOU settings in terms of what tariff periods apply to what zones, and what is the resulting maximum current setpoint in Amps based on the % reduction defined during tariff period definition.

**Time-of-use configuration**   [Periods configuration](#) [Zone where periods apply](#) [Summary](#)

Resulting maximum current per period and per zone based on defined time-of-use settings

Zone	Nominal current (A)	Current on "on-peak" (A)	Current on "off-peak" (A)	Current on "" (A)
1st Floor				
↳ 1st Floor - North	<b>150</b>	135	<b>150</b>	0
↳ 1st Floor - South	<b>150</b>	<b>150</b>	0	0
2nd Floor				
↳ 2nd Floor - North				

If you have disabled some period(s) on some zone(s), the current value shown for them will be the nominal one for the zone. That fact will be highlighted with cursive, bold font.

### 3.9.6 Disable TOU feature

You can disable or enable the TOU feature by clicking on this button

**Time-of-use configuration**    [Periods configuration](#) [Zone where periods apply](#) [Summary](#)

Define the time-of-use periods, their applicable timeslots and the % of reduction on maximum current setpoint to apply

Period name	Timeslots	Days	Maximum setpoint	Edit/Remove																				
<input checked="" type="checkbox"/> on-peak	<table border="1"> <tr> <th>Start time</th> <th>End time</th> </tr> <tr> <td>08h00</td> <td>12h00</td> </tr> <tr> <td>14h00</td> <td>19h30</td> </tr> </table>	Start time	End time	08h00	12h00	14h00	19h30	<table border="1"> <tr> <th>Monday</th> <th>Tuesday</th> <th>Wednesday</th> <th>Thursday</th> <th>Friday</th> <th>Saturday</th> <th>Sunday</th> </tr> <tr> <td>✓</td> <td>✓</td> <td>✓</td> <td>✓</td> <td>✓</td> <td></td> <td></td> </tr> </table>	Monday	Tuesday	Wednesday	Thursday	Friday	Saturday	Sunday	✓	✓	✓	✓	✓			90 %	
Start time	End time																							
08h00	12h00																							
14h00	19h30																							
Monday	Tuesday	Wednesday	Thursday	Friday	Saturday	Sunday																		
✓	✓	✓	✓	✓																				
<input checked="" type="checkbox"/> off-peak	<table border="1"> <tr> <th>Start time</th> <th>End time</th> </tr> <tr> <td>12h00</td> <td>14h00</td> </tr> </table>	Start time	End time	12h00	14h00	<table border="1"> <tr> <th>Monday</th> <th>Tuesday</th> <th>Wednesday</th> <th>Thursday</th> <th>Friday</th> <th>Saturday</th> <th>Sunday</th> </tr> <tr> <td>✓</td> <td>✓</td> <td>✓</td> <td>✓</td> <td>✓</td> <td></td> <td></td> </tr> </table>	Monday	Tuesday	Wednesday	Thursday	Friday	Saturday	Sunday	✓	✓	✓	✓	✓			0 %			
Start time	End time																							
12h00	14h00																							
Monday	Tuesday	Wednesday	Thursday	Friday	Saturday	Sunday																		
✓	✓	✓	✓	✓																				
<input type="checkbox"/>	<table border="1"> <tr> <th>Start time</th> <th>End time</th> </tr> <tr> <td>00h00</td> <td>00h00</td> </tr> </table>	Start time	End time	00h00	00h00	<table border="1"> <tr> <th>Monday</th> <th>Tuesday</th> <th>Wednesday</th> <th>Thursday</th> <th>Friday</th> <th>Saturday</th> <th>Sunday</th> </tr> <tr> <td></td> <td></td> <td></td> <td></td> <td></td> <td></td> <td></td> </tr> </table>	Monday	Tuesday	Wednesday	Thursday	Friday	Saturday	Sunday								%			
Start time	End time																							
00h00	00h00																							
Monday	Tuesday	Wednesday	Thursday	Friday	Saturday	Sunday																		

## 3.10 Energy Management through Digital inputs

Access: Admin tab → Configuration → Digital Input

### 3.10.1 Definition

This feature allows to define a reduced maximum current setpoint driven by EcoStruxure EV Charging Expert digital inputs.

EcoStruxure EV Charging Expert digital inputs (DI) are accessible through GPIO connections located on the bottom side. Up to 3 DI current limitations can be configured and enabled.



### 3.10.2 Prerequisites

This feature is only available for commercial references HMIBSCEA53D1ESM, -EDS, -EDM and -EDL.

### 3.10.3 Commissioning

- Energy management through DI setup and visualization are only available for Admin profile, to be configured during Operation phase (not configurable during initial commissioning phase).
- Click on “Digital Input configuration” button to enable the feature:

Network Remote supervision Load-shedding Zone management Power meters Time-of-use Digital Input Advanced

#### Digital Input configuration

Define the % of reduction on maximum current setpoint to apply based on the state of the digital inputs

# digital input	Name	Maximum setpoint	Edit
1	Input1	0%	
2	Input2	0%	
3	Input3	0%	

- Once the feature enabled, click on the Edit icon to update DI characteristics:
  - Maximum setpoint authorized values from 0 to 99%
  - To leave the field blank is not allowed

Network Remote supervision Load-shedding Zone management Power meters Time-of-use Digital Input Advanced

**Digital Input configuration** ■ ■

Define the % of reduction on maximum current setpoint to apply based on the state of the digital inputs

# digital input	Name	Maximum setpoint	Edit
1	Input1	0%	
2	Input2	0%	
3	Input3	0%	

Network Remote supervision Load-shedding Zone management Power meters Time-of-use Digital Input Advanced

**Digital Input configuration** ■ ■

Define the % of reduction on maximum current setpoint to apply based on the state of the digital inputs

# digital input	Name	Maximum setpoint	Edit
1	Input1	0%	
<div style="border: 2px solid green; padding: 10px; width: fit-content; margin: auto;"> <p>Name</p> <p>Input1</p> <p>Maximum setpoint</p> <p>0</p> <p><span style="background-color: #008000; color: white; padding: 2px 5px;">Save</span> <span style="background-color: #ccc; padding: 2px 5px;">Cancel</span></p> </div>			
2	Input2	0%	

- Each DI can be enabled / disabled separately:

Network Remote supervision Load-shedding Zone management Power meters Time-of-use Digital Input Advanced

**Digital Input configuration** ■ ■

Define the % of reduction on maximum current setpoint to apply based on the state of the digital inputs

# digital input	Name	Maximum setpoint	Edit
1	Input1	0%	
2	Input2	0%	
3	Input3	0%	

### 3.10.4 Electrical connection

- Digital inputs 1, 2 & 3 are driven by GPIO channels 1, 2 & 3:



- The pin 1,2,3 can be triggered by connected by the pin 8.
- **Each digital input is activated as both conditions are satisfied:**
  - enabled through EcoStruxure EV Charging Expert electrical commissioning
  - the corresponding GPIO channel is powered by 3.3 Vdc TTL.



**Note: An external 3,3 Vdc supply power needs to be foreseen. A higher voltage supply may damage the GPIO unit.**

### 3.10.5 Maximum setpoint management

- As the DI is activated the maximum setpoint reduction is applied to all zones
- Zone operating on static energy management:
  - Ratio of the maximum setpoint  
*Example: zone nominal setpoint 100A, DI maximum setpoint 80% -> zone reduced setpoint 80A*
- Zone operating on dynamic energy management:
  - Minimum between the ratio of maximum setpoint and the dynamic setpoint or the degraded setpoint in power meter loss  
*Example 1: zone nominal setpoint 100A, DI maximum setpoint 70%, dynamic setpoint 90A -> zone reduced setpoint 70A*  
*Example 2: zone nominal setpoint 100A, DI maximum setpoint 70%, dynamic setpoint 50A -> zone reduced setpoint 50A*  
*Example 3: zone nominal setpoint 100A, DI maximum setpoint 10%, degraded setpoint 30A -> zone reduced setpoint 10A*
- Setting maximum setpoint at 0% induce suspension of all loads
- DI energy management versus Time-of-Use:
  - As the DI is activated, the Time-of-Use settings are ignored
- Multiple DI activation:
  - As multiple DI are activated, the lowest maximum setpoint is applied.

## 3.11 Advanced configuration

Access: Admin tab → Configuration → Advanced

### 3.11.1 Definition

In this section you can configure EcoStruxure EV Charging Expert advanced parameters related to cybersecurity, power meters and webservices.

Advanced configuration setup and visualization are only available for Admin profile, during Operation phase (not during initial commissioning phase).

The screenshot shows the 'Advanced configuration' page for EcoStruxure EV Charging Expert. The page has a green header with the Schneider Electric logo and navigation tabs. The main content area is divided into two sections: 'Advanced configuration' and 'Webservices configuration'. The 'Advanced configuration' section includes several input fields and toggle switches. The 'Webservices configuration' section includes a link to 'Swagger API Documentation', a toggle for 'Activate', a toggle for 'Enable remote energy management', a text input for 'Remote energy management login', a toggle for 'Is remote energy management active?', a text input for 'Minimum period for zone setpoint update (in seconds)', a toggle for 'Enable time synchronisation', and a text input for 'Heart beat period (in seconds)'. A 'SAVE' button is located at the bottom left of the configuration area.

### 3.11.1 Cybersecurity

- **Session Timeout:** allows to define the web session timeout on web interface. The timeout is the duration in seconds without any interaction with the web interface. When the timeout is reached, the system will redirect to the login page.
- **Connection consecutive attempts before locking:** allows to define the maximum limit of unsuccessful connection attempts that are allowed with user or admin credentials before the system is locked.
- **Login locked period:** Allows to define in seconds the period during which the login is blocked after the previously define maximum unsuccessful login attempts.
- **Enable SSH:** Allow the user to enable or disable the access via SSH to the device

- **Authorize TLS:** Allow the user to allow or deny the use of TLS 1.3

### 3.11.2 Power meter

- **Power meter polling period:** allows to define in milliseconds the frequency of data acquisition from the power meters used for dynamic energy management.

### 3.11.3 Webservice configuration

EcoStruxure EV Charging Expert allows third-party system communication using a REST api. For more details on the api, please contact your Schneider Electric contact, or your Schneider Electric commercial partner.

- **Activate:** allows to activate communication via REST api. Please refer to API documentation for connection procedure. When webservice are activated a user with the role 'Webservices' must be created in the section 3.12.
- **Enable Remote EM:** allows to enable EcoStruxure EV Charging Expert setpoint update via webservice when REST api is activated.
- **Remote Energy Management login:** login of the dedicated user created for webservice connectivity. When there are multiple systems/users connected through api, only one can control Energy setpoints
- **Is remote Energy management Active:** this toggle is set by to 'On' when a system is connected via api. By default, the value is set to 'Off'. This parameter is read-only as it displays the status of the connection.
- **Minimal period for zone setpoint update:** allows to define the minimum period in second for setpoint update. If EcoStruxure EV Charging Expert receives several setpoint updates within this period, only the first value will be considered. Default value is 60 seconds.
- **Enable Time synchronization:** allows to enable the time synchronization with the 1/3 party system if the feature is supported by the system. We recommend disabling such synchronization when EcoStruxure EV Charging Expert is already connected to an OCPP platform.
- **Heartbeat period:** allows to define the time period for a periodic signal generated by the third-party system to indicate normal operation to EcoStruxure EV Charging Expert.

### 3.11.4 Miscellaneous

- **Enable Plug numbering:** This option is used when EcoStruxure EV Charging Expert manages products which have several sockets within the same connector (ie Smart Wallbox may have an optional domestic socket). When this option is set to 'on', EcoStruxure EV Charging Expert will use connector id 11 for the T2 socket and 12 for the domestic socket for OCPP messages with Central System. This option is relevant only if the central system supports such behavior. Default value is 'off'.



## 3.12 User management

Access by the Admin tab → Users management

### 3.12.1 User management landing page

Name	Role	Date of creation	Last access
Bruno	ADMIN	21/03/2019 14:22:48	25/03/2019 08:38:28
Youssef	USER	21/03/2019 14:23:18	21/03/2019 14:23:18

There are two profiles in the EcoStruxure EV Charging Expert:

**Admin:** full access to all configuration parameters

**User:** RFID card management, access to the dashboard in read-only mode

See [chapter 2.2.2](#) for login and password rules.

### 3.12.2 Add a user

All fields must be populated.

Current login

Current password

Please choose the role of the new user

Administrator

User

New Password

Confirm New Password

**CONFIRM**

**CANCEL**

### 3.12.3 Change the user password

All fields must be populated.

Current login

Current password

User login

New Password

Confirm New Password

CONFIRM

CANCEL

### 3.12.4 Delete a user

All fields must be populated.

Current login

Current password

User name to delete

CONFIRM

CANCEL

# 3.13 Charging station commissioning

Access: Admin tab → Station installation

## 3.13.1 Prerequisites

Charging stations must be powered and connected to the Ethernet network prior to the EcoStruxure EV Charging Expert commissioning. Charging stations must have the right firmware version, [see chapter 1.1.2.1 EVlink charging stations](#)

## 3.13.2 Charging station landing page

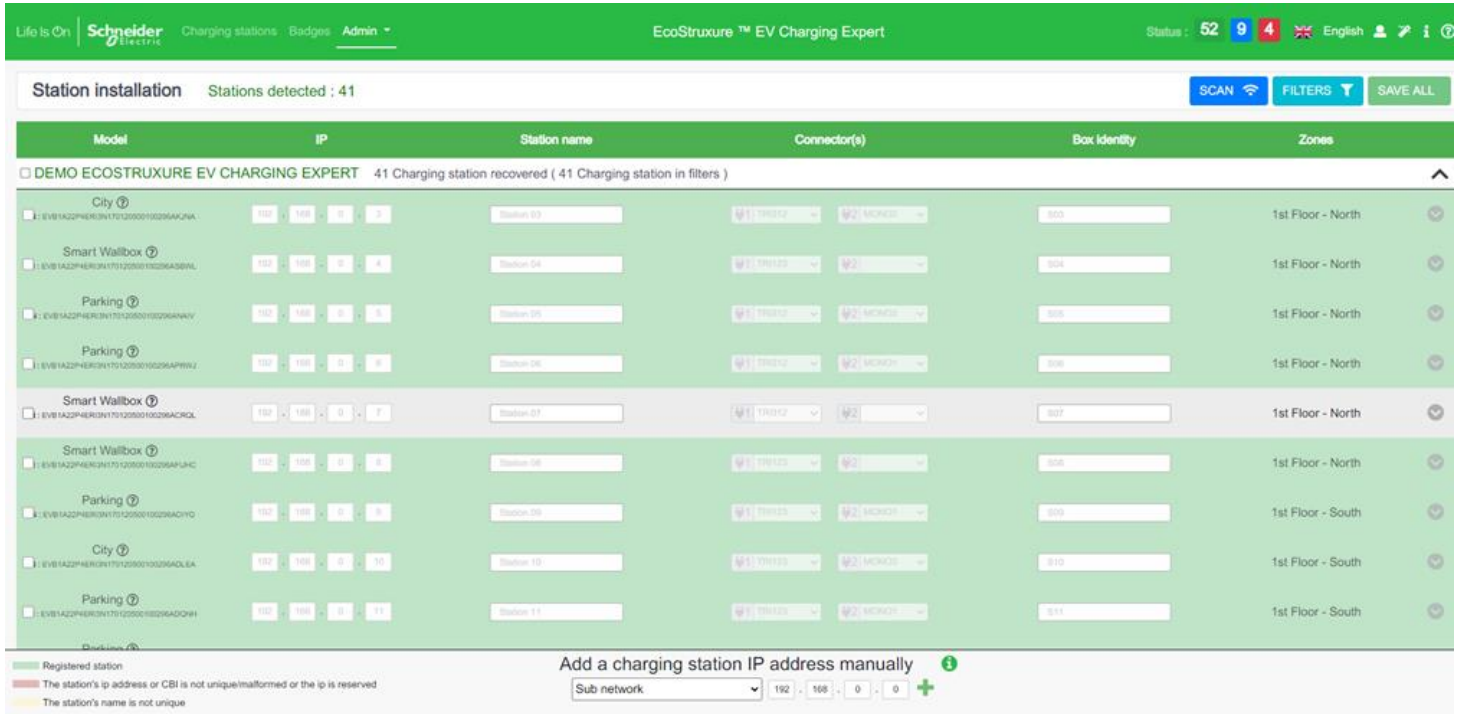

## 3.13.3 Description

Icon	Description
	Show all charging stations on the network
	Refresh the display charging station settings
	Save settings
	Add manually a charging station

## 3.13.4 Update charging station discovery

Steps	Description
1	Select the IP addresses scan range: enter the lowest and highest IP addresses. <b>Note: if you have changed the sub-network of the EcoStruxure EV Charging Expert during the Network step, please update the scan range addresses accordingly.</b>
2	Click

Steps	Description
3	<p>Update charging station settings:</p> <ul style="list-style-type: none"> <li>- IP Address: Change this parameter if the building IT manager imposes fixed IP addresses (avoid X.Y.X.50)</li> <li>- Station name: It is recommended to select a name that indicates the location of the station and the name of the parking (50 characters max)</li> <li>- Connector(s): in order to optimize load management, it is recommended to rotate the phases of the charging stations installed on the same site. Select here the phase wiring of each connector of the charging station according to the electrical wiring as implemented in the electrical network. e.g.</li> </ul> <div data-bbox="475 555 1273 824" style="text-align: center;"> </div> <ul style="list-style-type: none"> <li>- <b>VIP:</b> Check the box to activate the VIP status to the charging station.</li> <li>- <b>Auth mode:</b> The authentication mode will define the rules and strategy to grant access to the EV charging stations (see <a href="#">chapter 2.10</a>).</li> <li>- <b>Auth disconnected mode:</b> it allows to define the behavior when the connection between the charging stations and the EcoStruxure EV Charging Expert is lost. (see <a href="#">chapter 2.10</a>).</li> <li>- <b>Version:</b> Firmware version embedded in the charging station. See <a href="#">chapter 1.1.2.1</a> for compatibility.</li> <li>- <b>Box identity:</b> If the EcoStruxure EV Charging Expert is connected to a remote supervision, insert here the box identity provided by the Charge Point Operator (CPO). By default, it is the charging station MAC address. The box identity must not contain spaces.</li> <li>- <b>Zones:</b> Please choose the zone where the charging station belongs. Please note that the serial number of the charging station can be read by placing the pointer over the little question mark symbol next to each charging station model.</li> </ul>
4	Click the “Save All” button to initiate the configuration of the charging stations
5	Click “Next” to complete the step

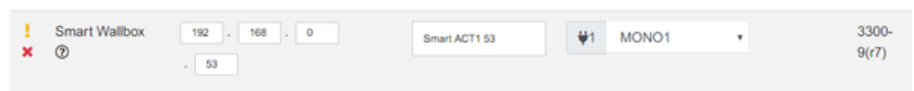

Note: It is possible that the installation of a charging station is not successful (marked with a red cross). In this case please relaunch the installation of the charging station.

During the configuration of the charging stations, the EcoStruxure EV Charging Expert will automatically update the firmware of the charging stations in the network to the charging station firmware version embedded in the EcoStruxure EV Charging Expert firmware.

### 3.13.5 Definition of authentication mode

The authentication mode will define the rules and strategy to grant access to the charging stations. Moreover, it allows to define the behavior of the charging stations

in the case that the connection between the charging stations and the EcoStruxure EV Charging Expert is lost.

The different authentication mode options are detailed on [chapter 2.10](#).

### 3.13.6 Filter your charging stations

You now have the possibility to filters your charging stations. You can filter by name, charge box identity, zone, and charging stations type (city, parking, ...). You also have the possibility to hide the charging stations that are already registered in your EcoStruxure EV Charging Expert.

# 3.14 Load shedding strategy and degraded mode

Access: Admin tab → Configuration → Load-shedding



Note: Whatever the parameters changed in degraded mode configuration, a reboot on the EcoStruxure EV Charging Expert and charging station must be done after the configuration.



Note: For the particular case of DC fast charging stations, the respect of the degraded mode instructions is not ensured, hence make sure the dimensioning of the electrical network and the nominal power provided to them are sufficient to avoid power outages.

## 3.14.1 Definition

The degraded mode is a parameter defining the current setpoint allocated to the charging station when the communication between the charging station and the EcoStruxure EV Charging Expert is lost. It is also the threshold under which the charge will be suspended in normal mode.

In dynamic mode, the EcoStruxure EV Charging Expert will favor the continuity of service of the building hence the current setpoint will be set to 0 A.

## 3.14.2 Prerequisites

The sum of the degrade mode setpoint must be lower than the max intensity of the zone. Otherwise, for safety and continuity of service reasons, **the EcoStruxure EV Charging Expert will automatically configure the current setpoint to 0A**

## 3.14.3 Degraded mode configuration page

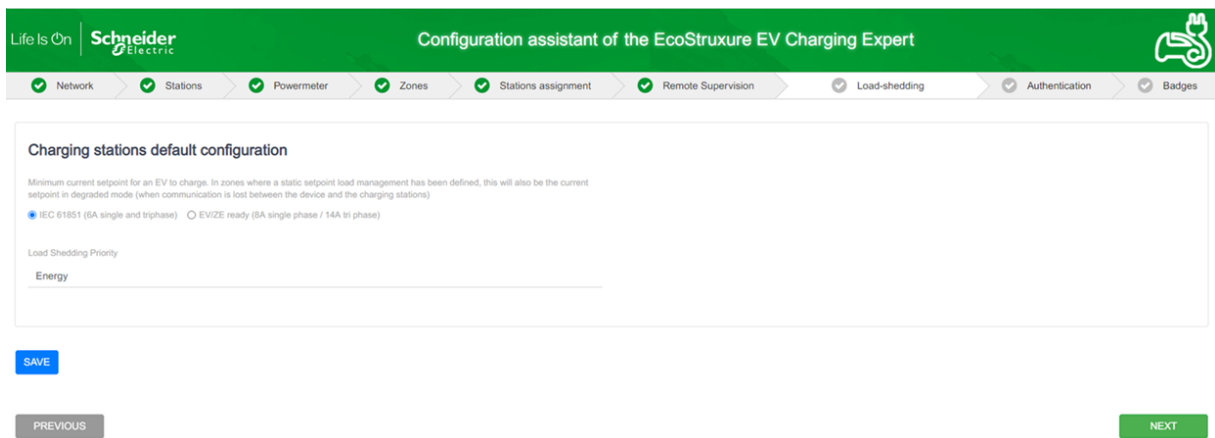

Step	Description
1	Select the minimum setpoint for your installation <ul style="list-style-type: none"> <li>- IEC 61851 ready (6A single phase and 3 phases)</li> <li>- EV/ZE ready (8A single phase and 14A 3 phases)</li> </ul>
2	Please choose the load shedding priority option: > <b>Energy</b> : Proportional to the energy consumed (kWh)

Step	Description
	<ul style="list-style-type: none"><li>• The system suspends the charging of vehicles which have consumed the highest amount of energy since the beginning of the charging process. This option is set by default.</li></ul> <p>&gt;<b>Duration:</b> Proportional to the charging time</p> <ul style="list-style-type: none"><li>• The system suspends the charging of vehicles which have charged for the longest time since the beginning of the charging process.</li></ul>
3	Click on "Next" to complete the process



Note: DC fast charging stations don't support degraded mode. Make sure the electric network is dimensioned and configured taking that into account.

## 3.15 Maintenance

### 3.15.1 Read EcoStruxure EV Charging Expert Logs

Access by the Admin tab → Logs

Date	Device	Type	Message
8/25/2020, 2:02:46 PM	LC	System	Transactions 1 transactions (SuspendedEV: 0 Loadshedding: 0)
8/25/2020, 2:02:45 PM	S40	Transaction	StopTransaction trid:1   extTrid:0   meterStop:100Wh   timeReceived:1598356965
8/25/2020, 2:02:45 PM	S40	Transaction	StatusNotification :   status:Finishing   timeReceived:0
8/25/2020, 2:02:45 PM	LC	Stats	uptime:73451 sysUptime:73464 load:25/42/59 freeram:1535M vmSize:1422M rss:25M
8/25/2020, 12:56:45 PM	LC	System	Transactions 1 transactions (SuspendedEV: 0 Loadshedding: 0)
8/25/2020, 12:56:45 PM	S40	Transaction	StatusNotification :   status:Available   timeReceived:0
8/25/2020, 12:56:44 PM	LC	System	Transactions 1 transactions (SuspendedEV: 0 Loadshedding: 0)
8/25/2020, 12:56:44 PM	S40	MeterValue	ImaxEV:0A Currents: 6.9A / 8.0A / 7.2A Energy: 0.000kWh
8/25/2020, 12:56:43 PM	LC	System	Transactions 1 transactions (SuspendedEV: 0 Loadshedding: 0)
8/25/2020, 12:56:43 PM	S40	Transaction	StatusNotification :   status:Charging   timeReceived:0

#### 3.15.1.1 Logs export

“Download Logs” button is used to export all logs in a csv file. Active filter is not considered in the export.

#### 3.15.1.2 Logs filter

“Filters” button allows to filter displayed logs by device (EcoStruxure EV Charging Expert or Charging Station), Zone or log type.

#### 3.15.1.3 Refresh

“Refresh” buttons allow to update the logs according to the latest events from the system.

### 3.15.2 Download the maintenance report

Access by the Admin tab → EcoStruxure EV Charging Expert Reports

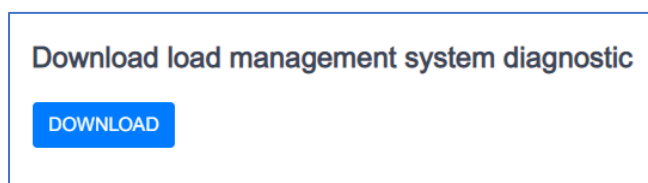

Click on Download button to get the EcoStruxure EV Charging Expert maintenance report in HTML format.



### 3.15.3 Download the Charging Stations maintenance report Logs

Access by the Admin tab → Station report

Station Name	Date	Type	Zone	Device
<input type="checkbox"/> Station 14 (0/5 reports selected)				
Station 14	11/20/2020, 3:15:51 PM	manually	1st Floor - North	Demo LMS
Station 14	11/20/2020, 3:16:02 PM	Event - Automatic	1st Floor - North	Demo LMS
Station 14	11/20/2020, 3:16:21 PM	Event - Automatic	1st Floor - North	Demo LMS
Station 14	11/20/2020, 3:47:59 PM	Event - Automatic	1st Floor - North	Demo LMS
Station 14	11/20/2020, 3:48:26 PM	Event - Automatic	1st Floor - North	Demo LMS
<input type="checkbox"/> Station 17 (0/5 reports selected)				
Station 17	11/20/2020, 3:53:37 PM	manually	1st Floor - North	Demo LMS
Station 17	11/20/2020, 3:53:47 PM	Event - Automatic	1st Floor - North	Demo LMS
Station 17	11/21/2020, 3:52:48 PM	Event - Automatic	1st Floor - North	Demo LMS
Station 17	11/22/2020, 3:52:47 PM	Event - Automatic	1st Floor - North	Demo LMS
Station 17	11/23/2020, 8:26:47 AM	Event - Automatic	1st Floor - North	Demo LMS

#### 3.15.3.1 Reports filter

Filter button allows to filter reports by devices (EcoStruxure EV Charging Expert or Station), zone, date and type (Periodic or User requested). Periodic reports are generated when EcoStruxure EV Charging Expert starts and every 24 hours afterwards.

#### 3.15.3.2 Download

Download button allows to download selected reports. All the reports will be archived into a single zip file. There is a 20 MB size limit for the content of the zip file that will prevent the download if exceeded.

#### 3.15.3.3 Create a charging station report

You have the possibility to create a report for your charging stations. To do so, go into the dashboard “charging stations” tab), then click on “all zones” on the left panel.

Then, you can click on the download icon on the charging stations that you want to create a report:

Name	Zone	Connector	Status	Phase	Action
Station 02	1st Floor - North	1	unavailable	TRI123	
Station 03	1st Floor - North	1	available	TRI312	
Station 04	1st Floor - North	1	charging	TRI123	
Station 05	1st Floor - North	1	available	TRI312	
Station 06	1st Floor - North	1	available	TRI312	

## 3.16 EcoStruxure EV Charging Expert firmware update

You can update the new firmware release of the EcoStruxure EV Charging Expert.

Access by the Admin tab → Firmware Update

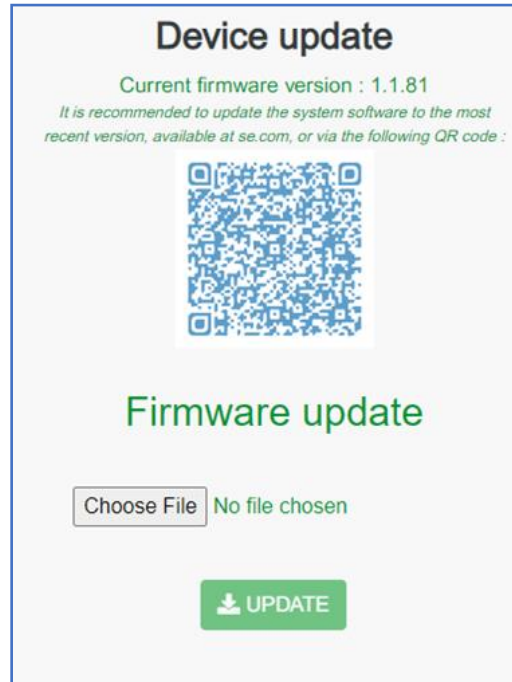

Click Choose file to select the binary file. The latest firmware release is available on se.com. You can use the following QR code or URL address to locate it:



<https://www.schneider-electric.com/en/product-range-download/62159-EVlink-load-management-system/?parent-category-id=1800&parent-subcategory-id=1840&filter=business-5-residential-and-small-business#/software-firmware-tab>

Click UPDATE to install the firmware in the EcoStruxure EV Charging Expert. Then reboot the EcoStruxure EV Charging Expert.

## 3.17 EcoStruxure EV Charging Expert License upgrade

You can upgrade your current EcoStruxure EV Charging Expert license to a more sophisticated one (for example, from a commercial reference able to manage up to 15 charging stations, to a new one able to manage up to 50 charging stations). If you wish to do so, please contact Schneider Electric, or your Schneider Electric commercial partner.

### 3.17.1 Get your EcoStruxure EV Charging Expert unique Identifier

You will need to provide the unique Identifier of your EcoStruxure EV Charging Expert product to get an upgrade package.

This unique identifier (Mac Address) is available from the 'Admin – License Upgrade' Menu:

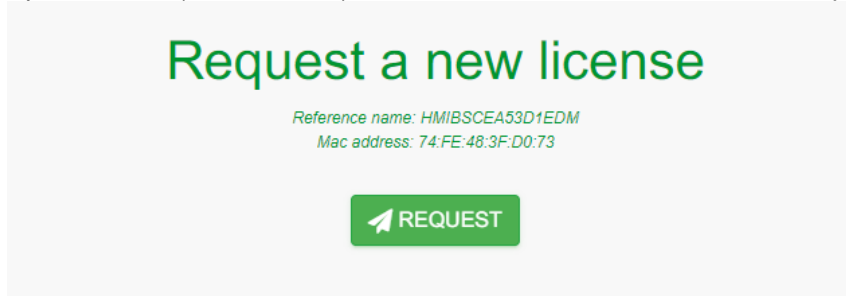

You can copy the Mac address and the current reference from this page or click on the “Request” button that will open your email tool to send this information by email to your Schneider Electric contact, or your Schneider Electric commercial partner.

### 3.17.2 Import the EcoStruxure EV Charging Expert upgrade package

When you receive your upgrade package from your Schneider Electric contact or your Schneider Electric commercial partner, you will have to upload it within the 'Admin – License Upgrade' Menu.

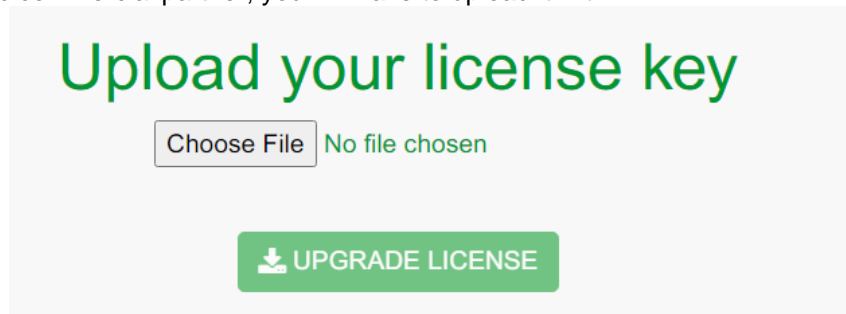

When you click on the Upgrade License button, the upgrade package will be installed and a reboot of the EcoStruxure EV Charging Expert is required.

## 3.18 Reboot and back to factory settings

### 3.18.1 Reboot and back to factory settings from the webserver

Access by the Admin tab → Reboot

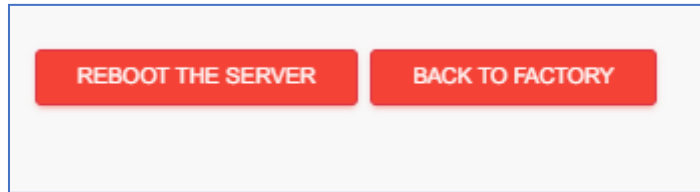

Click on “Reboot the server” to restart the EcoStruxure EV Charging Expert application.

Click on “Back to factory” to restore the EcoStruxure EV Charging Expert factory settings:

- The following data will be deleted:
  - RFID card list
  - Charging stations
  - Zones
  - Power meters
  - Transaction data
  - User list (except factory default user, ADMIN)
- The remote supervision connection will be removed
- The network settings will be reset

During the reboot process or the back to factory process the EcoStruxure EV Charging Expert will lose connection. A message will be shown on-screen for that. That is the normal behavior. Please wait a few seconds for the connection to be reestablished, or else refresh your browser.

### 3.18.2 Hardware back to factory settings

Refer to [chapter 5.1 Hardware back to factory settings](#).

# 3.19 Save and Restore

Access by the Admin tab → Save & Restore

## 3.19.1 Save the EcoStruxure EV Charging Expert configuration

The EcoStruxure EV Charging Expert allows to save a backup of the current system configuration to be able to import it later if needed and avoid having to reconfigure again the system.

The information that is backed up is the following:

- Admin and user profiles credentials
- Charging stations configuration
- Zones configuration
- Power meters configuration
- Network configuration
- Authentication strategy configuration
- List of RFID cards
- Charging data records

When you click Admin tab -> “Save & Restore”, the following pop-up is displayed. It allows to either save or restore the EcoStruxure EV Charging Expert configuration.

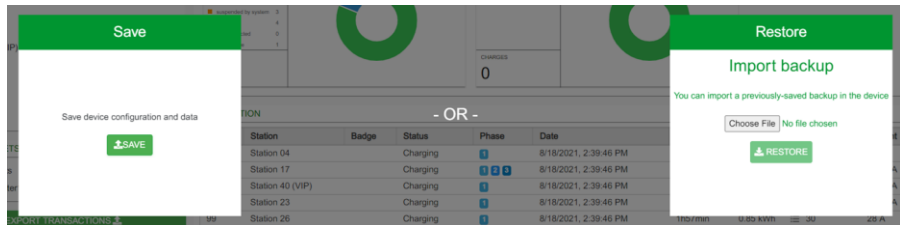

When clicking the button “Save”, a backup file is generated. For the security of your information, it is crypted and signed. It is advised to register it in a safe repository.

## 3.19.2 Restore during system commissioning

The “Save & Restore” pop-up during the system commissioning allows the user to restore a previously saved system configuration. It also allows to unselect the restoration of the administrator and user credentials so that, if the reason of the configuration restore is the loss of the administrator credentials and the consequent implementation of a hardware back-to-factory settings (see chapter 4.1), the administrator credentials can be recreated.

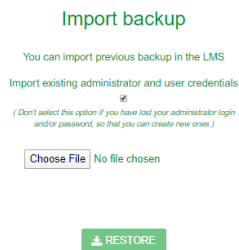

### 3.19.3 Restore during system operation

The “Save & Restore” pop-up during system operation (access via Admin tab) allows to either restore a previously-saved system configuration by choosing the appropriate file locally

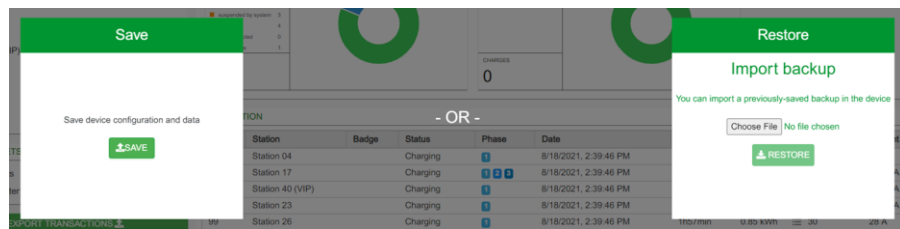

Note: The information about the transactions registered between the date of the backup and the current date will be lost when implementing a configuration restoration. If you don't want to lose them, please make sure you save them by exporting them prior to the restore. See chapter 1.1.1.4 to know how to do it.



Note: The information on the RFID cards added between the date of the backup and the current date will be lost when implementing a backup restore. If you don't want to lose them, please make sure you save them by exporting them prior to the restore. See chapter 3.4.4 to know how to do it.

# Chapter 4. **EcoStruxure** **EV Charging Expert** **Maintenance**

## 4.1 Hardware back to factory settings

### 4.1.1 Definition

If you find yourself in a situation where you can no longer access your EcoStruxure EV Charging Expert user interface (for example, because you have lost your Admin credentials, or if you have changed the network settings in a wrong way) you may consider restoring your EcoStruxure EV Charging Expert to its factory settings using the physical procedure to do it.

Note: When you reset your EcoStruxure EV Charging Expert to factory settings all data will be deleted. To know the list of data this procedure will delete, please refer to [chapter 3.19](#).

### 4.1.2 Prerequisites

EcoStruxure EV Charging Expert must be powered on.

### 4.1.3 Hardware back to Factory Settings procedure

Step	Description
1	<p>Create a wired bridge between the GPIO 7 and the GPIO 8 of the product connector for at least 5s.</p> 
2	<p>After at least 5s, remove the wired bridge.</p>
3	<p>Wait for the reboot of the product. You can now login to the EcoStruxure EV Charging Expert (configuration assistant, see <a href="#">chapter 2.1</a>).</p>



## 4.2 Regular cleaning and maintenance

### 4.2.1 Introduction

Inspect the EcoStruxure EV Charging Expert Box periodically to determine its general condition. For example:

- Are all power cords and cables connected properly? Have any become loose?
- Are all installation screws holding the unit securely?
- Is the ambient temperature within the specified range?

The following sections describe maintenance procedures for the EcoStruxure EV Charging Expert Box, which must be carried out by a trained, qualified user.

### DANGER

#### HAZARD OF ELECTRIC SHOCK, EXPLOSION OR ARC FLASH

- Remove all power from the device before removing any covers or elements of the system, and prior to installing or removing any accessories, hardware, or cables.
- Unplug the power cable from both the EcoStruxure EV Charging Expert Box and the power supply.
- Always use a properly rated voltage sensing device to confirm that power is off.
- Replace and secure all covers or elements of the system before applying power to the unit.
- Use only the specified voltage when operating the EcoStruxure EV Charging Expert Box. The AC unit is designed to use 100...240 Vac input. The DC unit is designed to use 24 Vdc input. Always check whether your device is AC or DC powered before applying power.

**Failure to follow these instructions will result in death or serious injury.**

During the operation, the surface temperature of the heat sink may exceed 70 ° C (158 ° F).

### WARNING

#### RISK OF BURNS

Do not touch the surface of the heat sink during operation.

**Failure to follow these instructions can result in death, serious injury, or equipment damage.**

### 4.2.2 Cleaning solutions

### CAUTION

#### HARMFUL CLEANING SOLUTIONS

- Do not clean the unit or any component of the unit with paint thinner, organic solvents, or strong acids.
- Use only a mild soap or detergent that will not harm the polycarbonate material of the screen.

**Failure to follow these instructions can result in injury or equipment damage.**

**Schneider Electric Industries SAS**

35, rue Joseph Monier  
CS 30323  
92506 Rueil Malmaison Cedex  
France

[www.se.com](http://www.se.com)

DOCA0163EN© 2020 Schneider Electric. All rights reserved