

Midi Horns and Sirens / Signal Horn 570

Signal horn WM Contin. tone 230VDC GY



Part No.: 570.052.58



MECHANICAL DATA	
Length	152 mm
Height	360 mm
Diameter	148 mm
Housing colour	Black
Protection category	IP55
Connection	Screw terminals
cross-sectional area maximum	2,50mm ² / 14AWG
Cable entry	Through hole
Cable entry maximum	d = 10 mm
Type of fixing	Wall mounting
Working temperature minimum	-20°C
Working temperature maximum	+60°C
Weight with packaging	1047 g
Product weight	916 g

ELECTRICAL DATA	
Operating voltage	230V
Operating voltage type	DC
Protection class	Protection class 2
Pollution degree	3
Overtoltage category	II
Isolation voltage	Ui = 250V; Uimp = 2.500V

ACOUSTIC DATA	
Acoustic signal image	Continuous tone
Acoustic service life	250 h minimum

APPROVAL DATA	
Conforms with CE	Yes
WEEE	Yes
Conforms with ATEX-directive	No
Conforms with CCC	No
Conforms with UL	No
Conforms with FCC	No
Conforms with IC	No
EAC certificate available	Yes
Conforms with UKCA (Importer)	Yes (WERMA (UK) Ltd.)
Conforms with AS-I	No
ICAO Certification	No

! For additional installation and mounting information, refer to the appropriate user guide at www.werma.com. This printed copy is for information only and is subject to alteration.

Midi Horns and Sirens / Signal Horn 570

Signal horn WM Contin. tone 230VDC GY

Conforms with DNV	No
Conforms with RoHS CN	No
Conforms with VdS	No

DRAWING

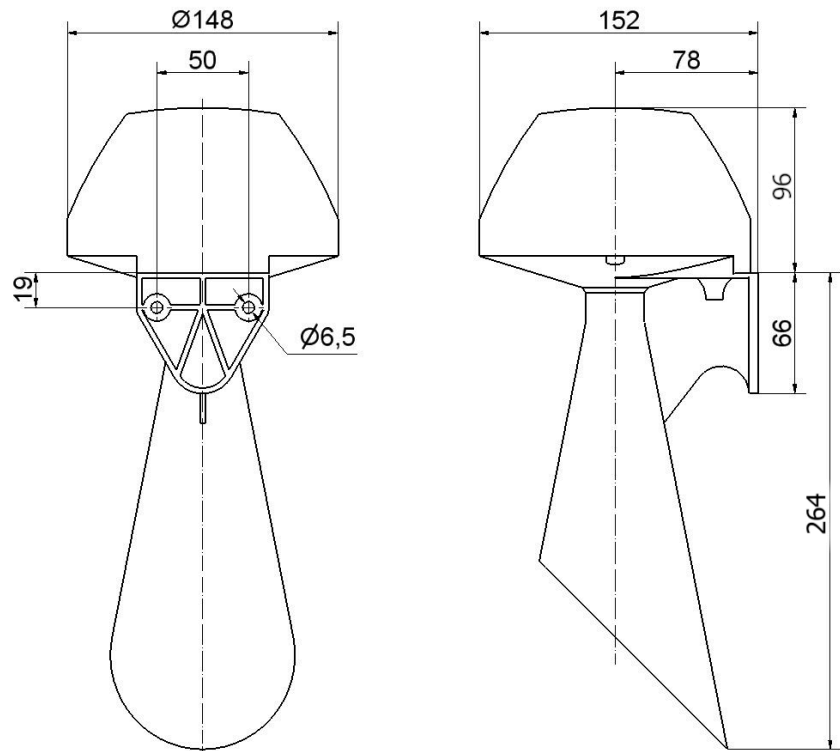

! For additional installation and mounting information, refer to the appropriate user guide at www.werma.com. This printed copy is for information only and is subject to alteration.