

Midi Horns and Sirens / Signal Horn 570

Signal horn WM Contin. tone 115VAC GY

Part No.: 570.052.67

**MECHANICAL DATA**

Length	152 mm
Height	360 mm
Diameter	148 mm
Materials	PC/ABS
Housing colour	Grey
Protection category	IP55
Connection	Screw terminals
cross-sectional area maximum	2,50mm ² / 14AWG
Cable entry	Through hole
Cable entry maximum	d = 10 mm
Type of fixing	Wall mounting
Working temperature minimum	-20°C
Working temperature maximum	+60°C
Weight with packaging	1067 g
Product weight	942 g

ELECTRICAL DATA

Operating voltage	115V
Operating voltage type	AC
Operating voltage frequency	60Hz
Operating voltage tolerance	+/- 10%
Rated operational voltage	115 VAC
Rated operational current	200 mA
Rated inrush current	<500mA
Protection class	Protection class 2
Pollution degree	3
Overtoltage category	II
Isolation voltage	Ui = 250V; Uimp = 2.500V

ACOUSTIC DATA

Volume (max) at 1m distance	108,0 dB (A)
Acoustic signal image	Continuous tone
Acoustic service life	250 h minimum

APPROVAL DATA

Conforms with CE	Yes
WEEE	Yes
Conforms with ATEX-directive	No
Conforms with CCC	No



For additional installation and mounting information, refer to the appropriate user guide at www.werma.com. This printed copy is for information only and is subject to alteration.

Midi Horns and Sirens / Signal Horn 570

Signal horn WM Contin. tone 115VAC GY

Conforms with UL	No
Conforms with FCC	No
Conforms with IC	No
EAC certificate available	Yes
Conforms with UKCA (Importer)	Yes (WERMA (UK) Ltd.)
Conforms with AS-I	No
ICAO Certification	No
Conforms with DNV	No
Conforms with RoHS CN	No
Conforms with VdS	No

DRAWING

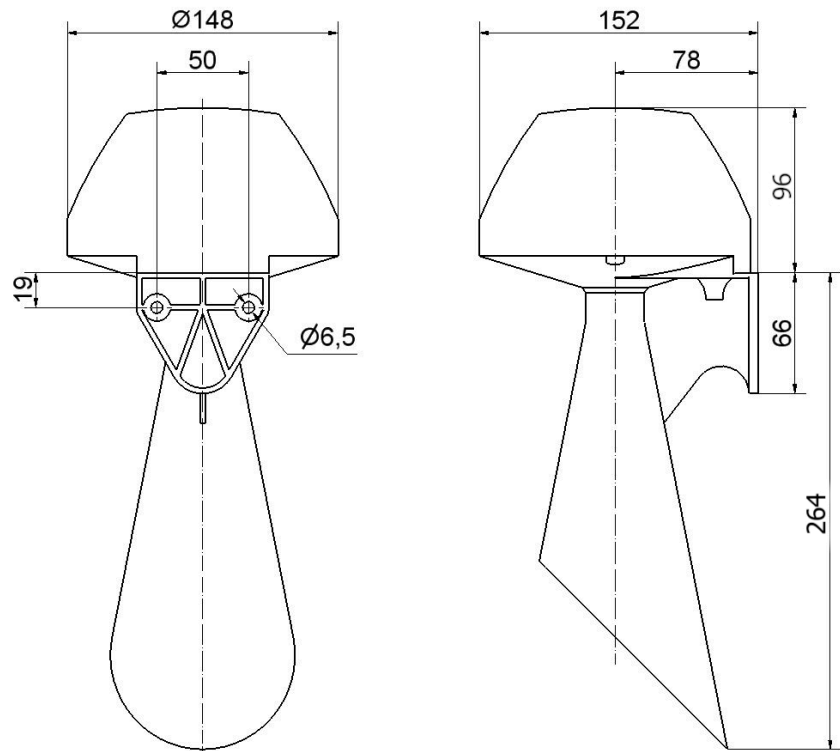

For additional installation and mounting information, refer to the appropriate user guide at www.werma.com. This printed copy is for information only and is subject to alteration.