

Midi Horns and Sirens / Signal Horn 570

**Signal horn WM Contin. tone 115VAC GY**

Part No.: 570.052.67

**MECHANICAL DATA**

Length	152 mm
Height	360 mm
Diameter	148 mm
Materials	PC/ABS
Housing colour	Grey
Protection category	IP55
Connection	Screw terminals
cross-sectional area maximum	2,50mm <sup>2</sup> / 14AWG
Cable entry	Through hole
Cable entry maximum	d = 10 mm
Type of fixing	Wall mounting
Working temperature minimum	-20°C
Working temperature maximum	+60°C
Weight with packaging	1027 g
Product weight	860 g

**ELECTRICAL DATA**

Operating voltage	115V
Operating voltage type	AC
Operating voltage frequency	60Hz
Operating voltage tolerance	+/- 10%
Rated operational voltage	115 VAC
Rated operational current	200 mA
Rated inrush current	<500mA
Protection class	Protection class 2
Pollution degree	3
Overtoltage category	II
Isolation voltage	Ui = 250V; Uimp = 2.500V

**ACUSTICAL DATA**

Volume (max) at 1m distance	108,0 dB (A)
Acoustic signal image	Continuous tone
Acoustic service life	250 h minimum

**APPROVAL DATA**

Conforms with CE	yes
WEEE	yes
Conform with ATEX-directive	no
Conforms with CCC	no



For additional installation and mounting information, refer to the appropriate user guide at [www.werma.com](http://www.werma.com). This printed copy is for information only and is subject to alteration.

Midi Horns and Sirens / Signal Horn 570

**Signal horn WM Contin. tone 115VAC GY**

Conforms with UL	nein
Conforms with FCC	no
Conforms with IC	No
EAC Zertifikat vorhanden	yes
Conforms with AS-I	no
ICAO Certification	No
Conforms with GL	no
Conforms with RoHS CN	no
Conforms with VdS	no

**DRAWING**

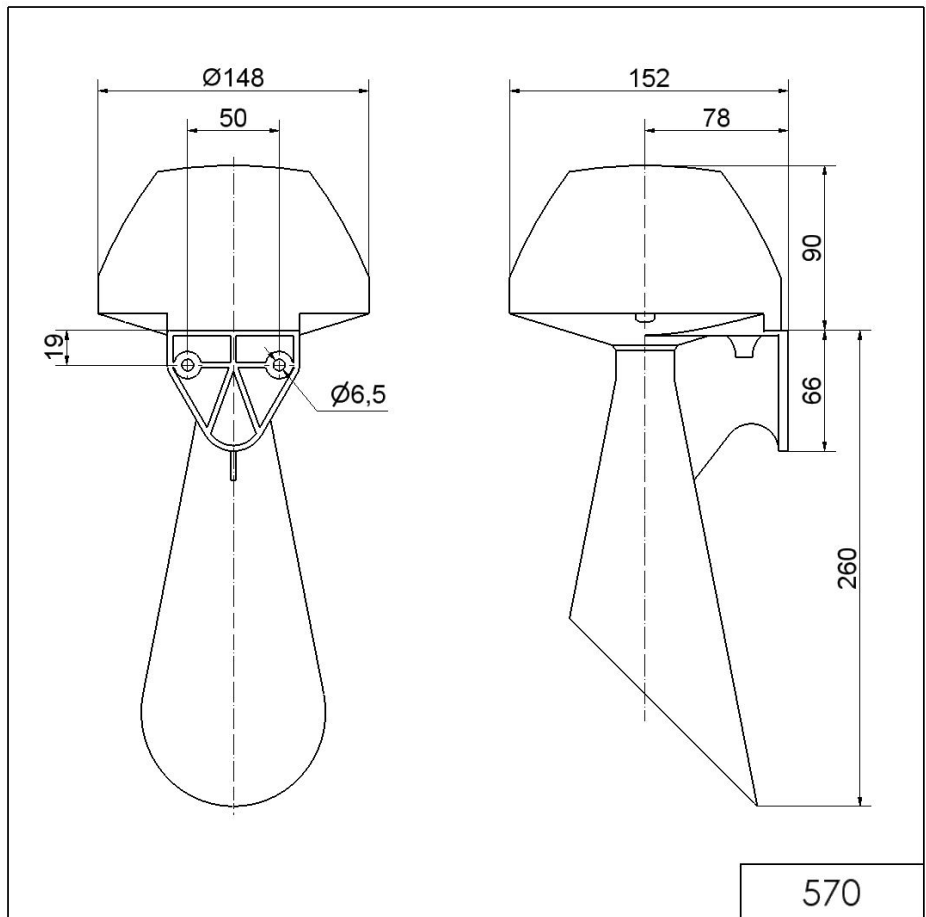

For additional installation and mounting information, refer to the appropriate user guide at [www.werma.com](http://www.werma.com). This printed copy is for information only and is subject to alteration.