

Sentinel Apex

Commercial Heat Recovery

Installation, Operation & Maintenance

Original Instructions

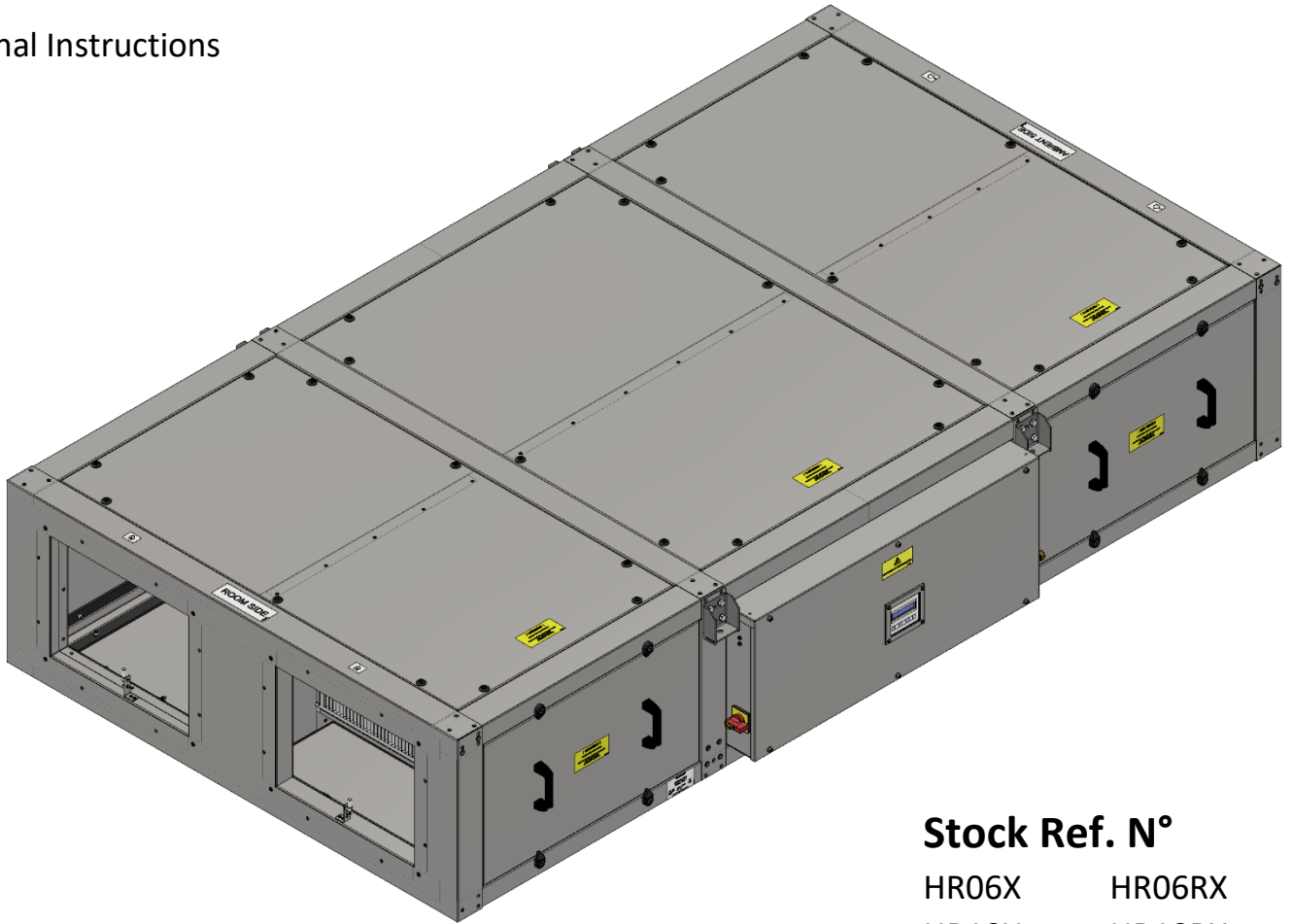

Stock Ref. N°

HR06X	HR06RX
HR10X	HR10RX
HR15X	HR15RX
HR21X	HR21RX



**PLEASE READ THESE INSTRUCTIONS CAREFULLY
BEFORE COMMENCING INSTALLATION OR OPERATION.**

**PLEASE REFER TO ACCOMPANYING DOCUMENTATION FOR
INFORMATION SPECIFIC TO YOUR UNIT.**

PLEASE RETAIN THESE INSTRUCTIONS WITH THE PRODUCT.



Warnings & Safety Information

- THESE UNITS MUST BE SITED AND CONNECTED IN ACCORDANCE WITH CURRENT IET REGULATIONS, BS7671 (UK) OR THE APPROPRIATE STANDARDS IN YOUR COUNTRY.
- INSTALLATION SHOULD BE BY A QUALIFIED ELECTRICIAN AND INSTALLER.
- FIXED WIRING AND RIGID CONDUCTORS ARE TO BE USED ON ALL EXTERNAL CABLING.
- ALL REGULATIONS AND REQUIREMENTS MUST BE STRICTLY FOLLOWED TO PREVENT HAZARDS TO LIFE AND PROPERTY, BOTH DURING AND AFTER INSTALLATION, AND DURING ANY SUBSEQUENT SERVICING AND MAINTENANCE.
- THESE UNITS MUST BE EARTHED.
- SITE THE UNIT AWAY FROM DIRECT SOURCES OF HEAT. AMBIENT TEMPERATURE RANGE -10°C TO 40°C.
- WHEN INSTALLING UNIT, TAKE CARE NOT TO DAMAGE ELECTRICAL OR OTHER HIDDEN UTILITIES.
- CHECK THE DETAILS ON THE RATING LABEL FOR CORRECT VOLTAGE AND ELECTRICAL RATING.
- THE INSTALLER IS RESPONSIBLE FOR THE INSTALLATION AND ELECTRICAL CONNECTION OF THE SENTINEL SYSTEM ON SITE. IT IS THE RESPONSIBILITY OF THE INSTALLER TO ENSURE THAT THE EQUIPMENT IS SAFELY AND SECURELY INSTALLED AND LEFT ONLY WHEN MECHANICALLY AND ELECTRICALLY SAFE.
- DUE TO THE WEIGHT OF THE UNITS, IT IS RECOMMENDED THAT MULTIPLE PERSONS ARE INVOLVED IN THE INSTALLATION. AT ALL TIMES, INSTALLATION PRACTICES MUST COMPLY WITH RELEVANT HEALTH AND SAFETY LEGISLATION.
- SENTINEL APEX UNITS ARE DESIGNED AND SPECIFIED FOR USE WITH VENT-AXIA CONTROLS, DAMPERS, GRILLES AND ACCESSORIES.
- DISCONNECT THE APPLIANCE FROM ITS POWER SOURCE DURING SERVICE AND WHEN REPLACING PARTS
- CHILDREN OF LESS THAN 3 YEARS SHOULD BE KEPT AWAY.
- CHILDREN AGED FROM 3 YEARS AND LESS THAN 8 YEARS SHALL ONLY SWITCH ON/OFF THE APPLIANCE PROVIDED THAT IT HAS BEEN INSTALLED IN ITS INTENDED NORMAL OPERATING POSITION AND THEY HAVE BEEN GIVEN SUPERVISION OR INSTRUCTION CONCERNING USE OF THE APPLIANCE IN A SAFE WAY AND UNDERSTAND THE HAZARDS INVOLVED. CHILDREN AGED FROM 3 YEARS AND LESS THAN 8 YEARS SHALL NOT PLUG IN REGULATE AND CLEAN THE APPLIANCE OR PERFORM USER MAINTENANCE
- THIS APPLIANCE CAN BE USED BY CHILDREN AGED FROM 8 YEARS AND ABOVE AND PERSONS WITH REDUCED PHYSICAL, SENSORY OR MENTAL CAPABILITIES OR LACK OF EXPERIENCE OR KNOWLEDGE IF THEY HAVE BEEN GIVEN SUPERVISION OR INSTRUCTION CONCERNING USE OF THE APPLIANCE IN A SAFE WAY AND UNDERSTAND THE HAZARDS INVOLVED. CHILDREN SHALL NOT PLAY WITH THE APPLIANCE. CLEANING AND USER MAINTENANCE SHALL NOT BE MADE BY CHILDREN WITHOUT SUPERVISION.

- PRECAUTIONS MUST BE TAKEN TO AVOID THE BACKFLOW OF GASES INTO THE ROOM, FROM THE OPEN FLUE OF GAS OR OTHER FUEL BURNING APPLIANCES.
- THIS UNIT SHOULD NOT BE USED IN A GREASE-LADEN ATMOSPHERE.
- CAUTION – SOME PARTS OF THIS PRODUCT CAN BECOME VERY HOT AND CAUSE BURNS. PARTICULAR ATTENTION HAS TO BE GIVEN WHERE CHILDREN AND VULNERABLE PEOPLE ARE PRESENT.

Contents

Product Description	6
Technical Specification	8
Sentinel Apex Technical Specification	8
Unit Dimensions & Weights	9
Minimum Maintenance Access Clearances	10
Installation	11
Overview	11
Before Installing Your Equipment	12
Physical Installation	13
Electrical Installation	16
Operating and Monitoring	20
Switching On/Off	20
Overview	21
Onboard HMI	21
Remote HMI	26
Engineer menu	34
Mobile App	41
Maintenance	42
Caring for your Unit	42
6-Monthly Maintenance	42
12-Monthly Maintenance	42
5-Yearly Maintenance	42
Removal/Replacement of Parts	43
Panel Removal/Replacement	43
Filter Removal & Replacement (Side Access)	47
Filter Removal & Replacement (Bottom Access)	48
Motor Removal & Replacement (Roof-Mounted)	49
Motor Removal & Replacement (Ceiling-Mounted)	50
Heat Exchanger Removal & Replacement (Roof-Mounted)	51
Heat Exchanger Removal & Replacement (Ceiling-Mounted)	52
Condensate Sensor Removal & Replacement (Roof-Mounted)	54
Condensate Sensor Removal & Replacement (Ceiling-Mounted)	55
Condensate Pump Removal & Replacement	55
Pre-Heater Removal & Replacement	57
Actuator Removal & Replacement	60
Actuator PSU Removal & Replacement (HR21X Model ONLY)	61
Main Control PCB Removal & Replacement	62
Pressure Sensor PCB Removal & Replacement	63
Heater Control PCB Removal & Replacement	64

Overheat thermostats Resetting, Removal & Replacement	66
Thermistors Removal & Replacement	67
List of Spares	68
Troubleshooting	69
Diagnosing a Problem	69
Status LED	69
Diagnostic Codes	69
Power Supply Troubleshooting	70
Airflow Troubleshooting	70
Temperature Troubleshooting	70
Condensate Troubleshooting	71
Appendices	72
Appendix A: Glossary	72
Appendix B: Options and Accessories	73
Appendix C: Main Controller PCB Terminals	74
Appendix D: Modbus Registers	75
Appendix E: Commissioning Record	76
Appendix F: Additional Technical Data	77

Product Description

Sentinel Apex Demand Energy Recovery Ventilation (D-ERV) is a heat recovery demand ventilation system designed to meet modern building management and control principles. Performance simply delivered with more as standard.

Vent-Axia's Sentinel Apex range of commercial heat recovery units with up to 93% EN308 heat recovery efficiency, low sound levels and low specific fan powers the range provides high levels of performance efficiently. A new advanced control system that provides on board control, in room control and App based control full functionality commissioning and monitoring is simply provided. This control can be coupled with Vent-Axia's new range of sensors with wired or wireless communication providing close control of, and monitoring of your indoor air quality. Sensors include CO₂, humidity and temperature and provide both proportional and switch control.

The Sentinel Apex unit is manufactured with a double skinned construction incorporating Aluzinc frames and panels. The panels are acoustically and thermally treated with 90kg/m³ high efficiency acoustic and thermally insulating foam (fire retardant to BS476 Part 7 Class 1 & Part 6 Class O). The construction of the unit, IPX4, allows for internal and external mounting as standard, however, the roof assembly should be included for full external locations.

The housing is designed to be as compact as possible for concealed false ceiling applications with top and bottom access panels for maintenance. Access panels are sized to enable single man maintenance.

The fans utilised in the Sentinel Apex are the latest EC/DC external rotor motors specifically chosen for their low power consumption and low noise characteristics. The assembly is dynamically balanced to DIN ISO 1940 Grade 6.3. Ball bearings are greased for life. Insulation is Class 'B' (from -25°C to +60°C). All models incorporate internal electronic overload protection and a soft start function.

The Sentinel Apex is complete as standard with ISO ePM10 50% (M5) extract filter and ISOePM1 50% (F7) supply, complete with a filter change warning. Filters have been selected to fully comply with the requirements of ISO16890 whilst having low pressure loss characteristics.

An integral electric frost heater is included to provide frost protection of the cell and filters down to minus 10°C. The integral controls also allow this heater to be utilised as a top up heater.

The unit is complete with an integral summer bypass facility which has been designed to provide full bypass without impact to the airflow or power consumption of the unit whilst in bypass mode.

Airflow and power consumption tested in accordance with BS EN 5801. Sound data derived from independent testing at Sound Research Laboratories in accordance with EN ISO 3741:2010. Published dB(A) figures are free field sound pressure levels at 3m with spherical propagation at a reference level of 2×10^{-5} Pa. The inlet/outlet sound power level spectra figures are dB with a reference of 10–12 watts.

An integral condensate tray is fitted along with an internal quiet running high quality pump allowing for removal of the condensate via a 10mm condensate pipe.

To facilitate normal access and maintenance to the unit there are both side and bottom access panels as standard. Should it be required, all panels are removable allowing access and removal of the heat recovery cell and all other components. A lockable isolator is fitted to the control panel preventing accidental operation whilst any maintenance is being carried out.

The electrical supply for the unit is 230V +/- 10% / 50 / 60Hz / 1ph. A 24V DC power is available from the unit for powering any of the matched sensors and switches.

The Sentinel Apex unit is fitted with an integrated control system as standard with a purpose designed user interface controller incorporating an alphanumeric 2-line display with 4 button keypad for fan status and a basic commissioning setup mounted within the control panel. A remote HMI is also included for that can be mounted within the room that is being ventilated. This allows for local monitoring of the unit along with the commissioning set-up.

App based control is also available via the Vent-Axia Connect App. This provides detailed commissioning and monitoring information and the ability to control the unit remotely.

A full range of sensors is available including humidity, temperature and CO2 monitoring. These sensors are available for both wired and wireless communication with the wireless sensors being either local mains or battery powered.



Models:

- **HR06X** designed to operate at airflows of up to 650 m³/hr at 150 Pa.
- **HR10X** designed to operate at airflows of up to 1000 m³/hr at 150 Pa.
- **HR15X** designed to operate at airflows of up to 1500 m³/hr at 150 Pa
- **HR21X** designed to operate at airflows of up to 2100 m³/hr at 150 Pa

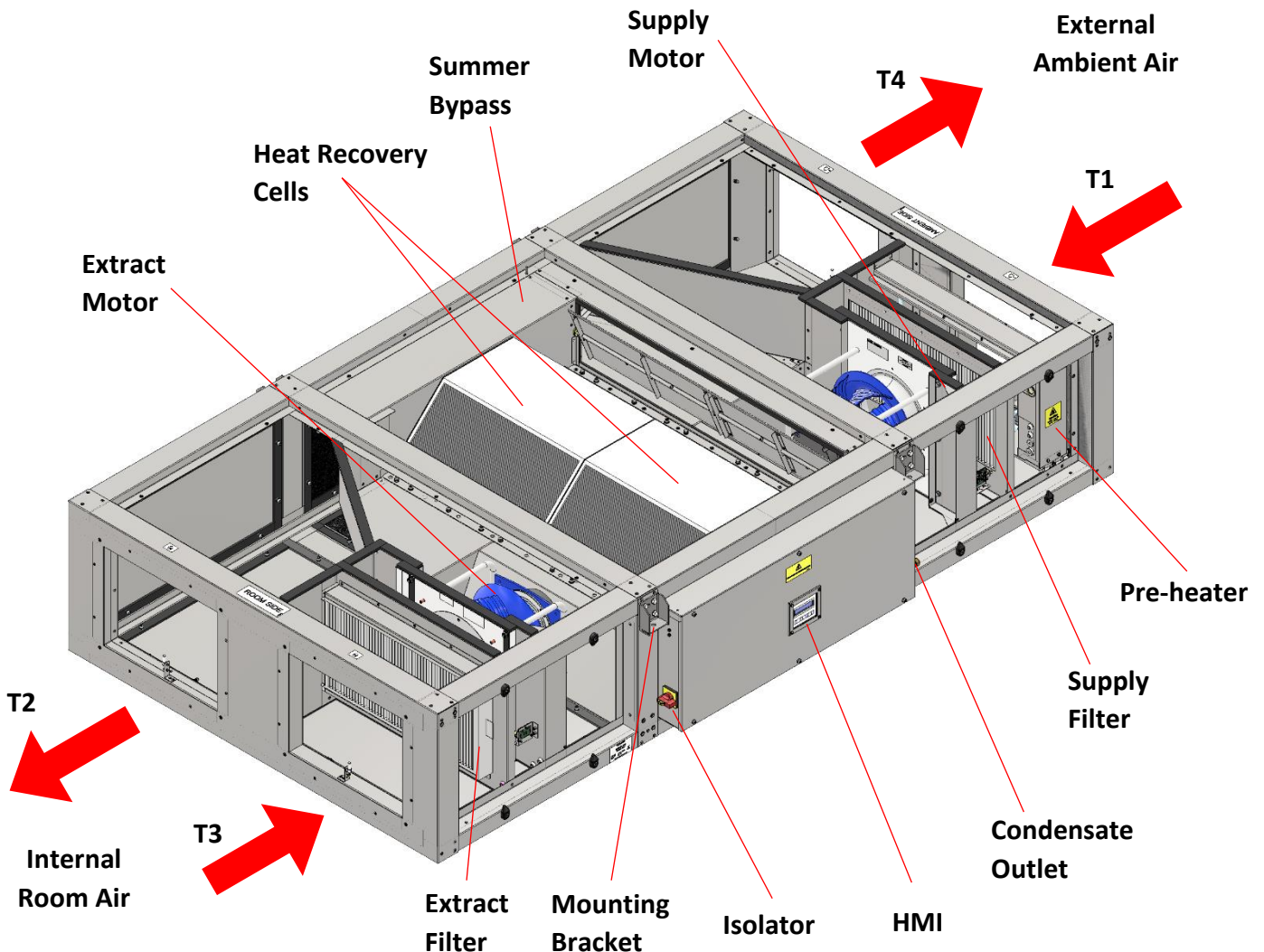

Technical Specification

Sentinel Apex Technical Specification

Performance	HR06X	HR10X	HR15X	HR21X
Airflow (nominal)	650 m ³ /hr at 150 Pa	1000 m ³ /hr at 150 Pa	1500 m ³ /hr at 150 Pa	2100 m ³ /hr at 150 Pa
Power				
AC Voltage Input	220-240 V ac (One, Two, or Three Single Phases)			
AC Frequency Input	50/60 Hz nominal			
Supply Fuse or Cct Breaker	16A	16A	32A	45A
Rated Current	12A	14A	29A	39A
Rated Power	2800W	3200W	6700W	8800W
Total Fan Power (max.)	340W	340W	1000W	960W
Total Frost Heater (max.)	2400W	2800W	5600W	7800W
DC Voltage Output	24 V _{DC} , 0.3A between the POWER OUT terminals 24Vdc, 0.1A shared between proportional 0-10V inputs 5Vdc, 0.1A shared between digital SW inputs			
Battery	CR2032 (See Maintenance section on page 42)			
Product Fuses				
Main Controller PCB	F1: 2A T 250V, F2: 8A M 250V (See installation section for further details)			
Environmental				
IP Rating - Unit	IPX2 (IPX4 with Weather Accessories required for outdoor mounting, see Appendix B)			
Operating Temperature	-10°C to +40°C			
Operating Humidity	0% to 95% (non-condensing) – weatherproof unit option			
Storage Temperature	-10°C to +40°C			
Storage Humidity	0% to 95% (non-condensing)			
Condensate Pump	8 L/hr @ 8m head, 16 L/hr @ 2m head. 8m Max Head			

Unit Dimensions & Weights

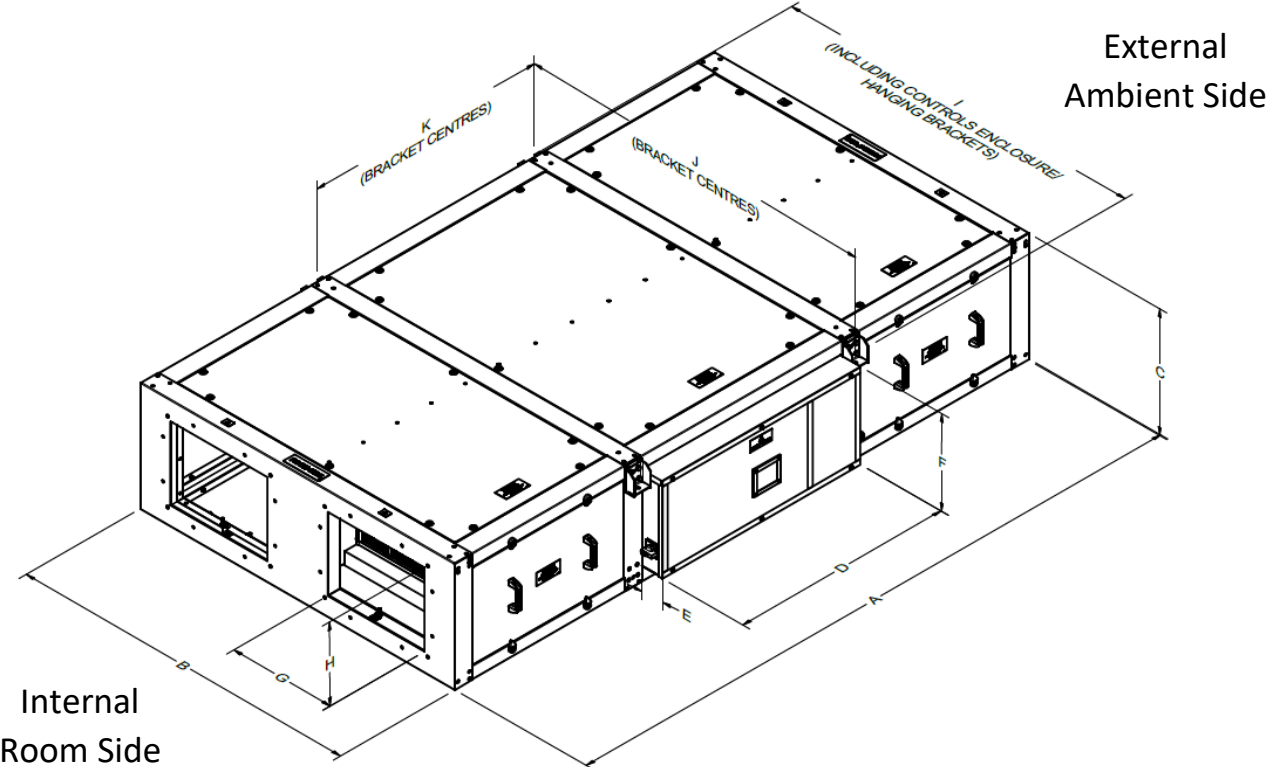

Figure 1: Unit Dimensions

DIMENSIONS TABLE (mm)				
IDENTIFICATION	HR06X	HR10X	HR15X	HR21X
A (LENGTH)	2141	2400	2400	2965
B (WIDTH)	1323	1312	1312	1319
C (HEIGHT)	350	460	460	620
D	719	831	831	1024
E	89	88	88	88
F	248	356	356	518
G	400	400	400	500
H	200	300	300	400
I	1450	1440	1440	1446
J	1363	1353	1353	1359
K	791	908	908	1097
WEIGHT	275 Kg	338 Kg	348 Kg	470 Kg

Note: Standard arrangement shown. Opposite handed units available by special order.

Minimum Maintenance Access Clearances

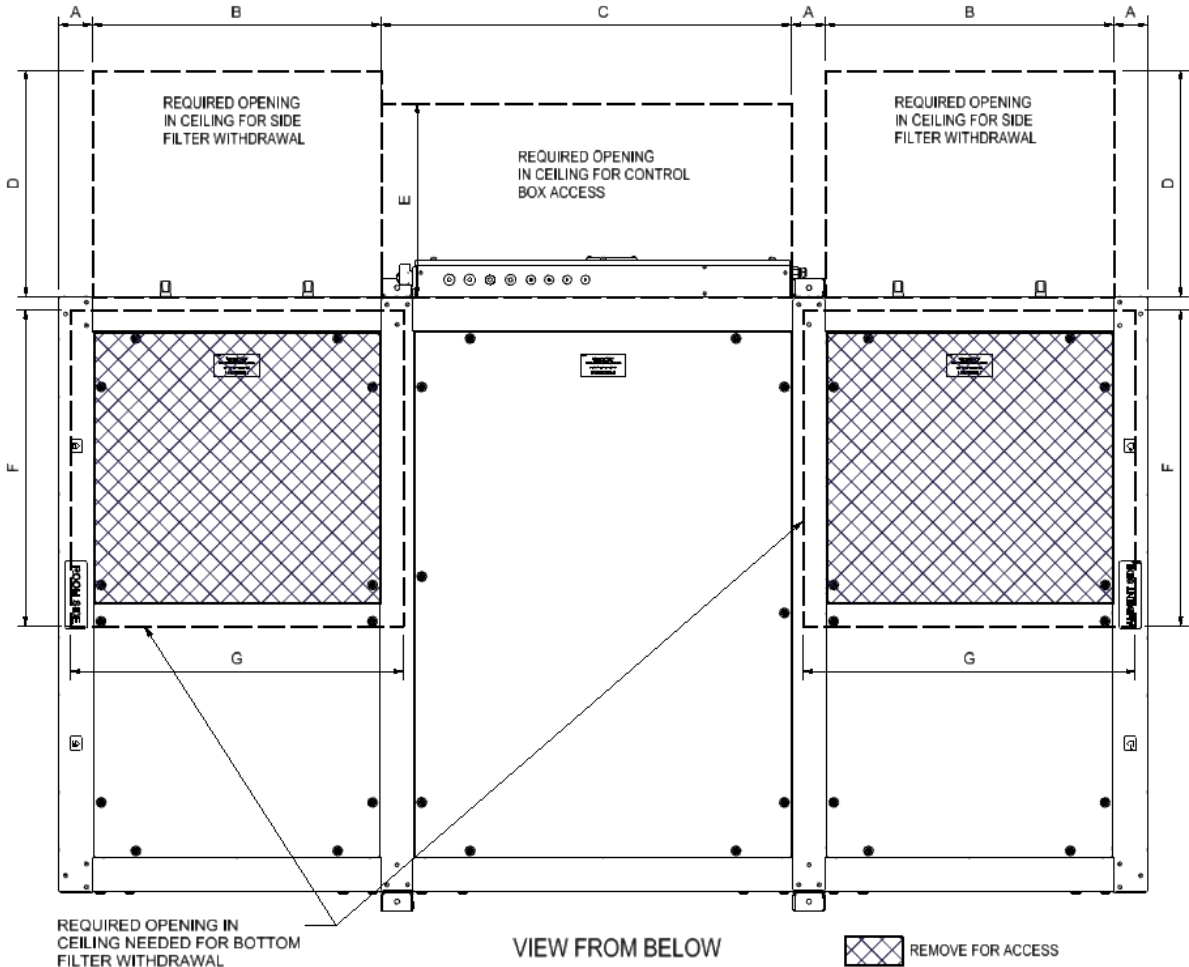

Figure 2: Maintenance Access - View from Below

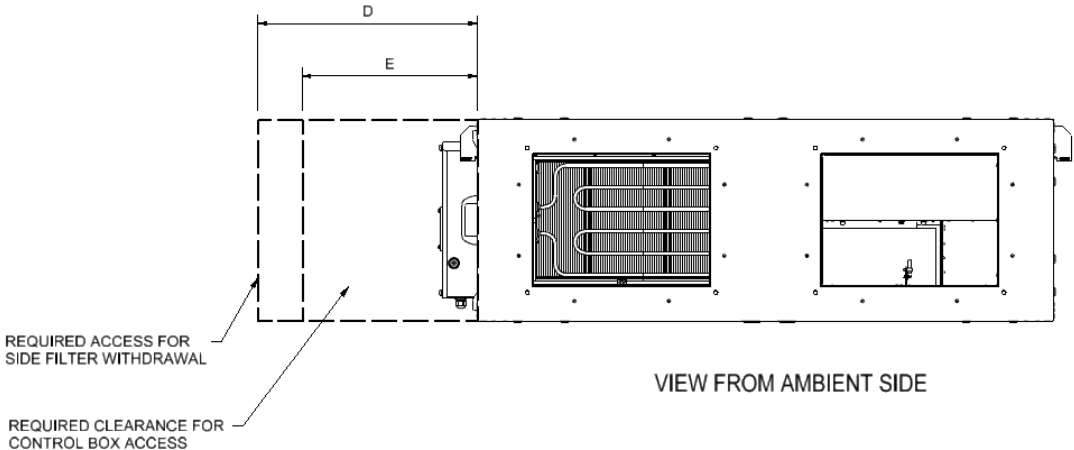

Figure 3: Maintenance Access - View from Side

DIMENSIONS (mm)							
MODEL	A	B	C	D	E	F	G
HR06X	75	560	790	650	500	670	660
HR10X	75	630	910	650	500	700	730
HR15X	75	630	910	650	500	700	730
HR21X	75	820	1100	660	500	700	920

Installation

Overview



WARNING

THIS EQUIPMENT PRESENTS ELECTRICAL, MECHANICAL AND NOISE HAZARDS. FAILURE TO USE SAFE WORKING PRACTICES AND OBSERVE THE RELEVANT REGULATIONS MAY RESULT IN DEATH OR SERIOUS INJURY.

The following instructions are intended to help prevent and/or minimize potential hazards and should be carried out only by a qualified electrician and installer.

The figure below summarises the instructions given in the following paragraphs.

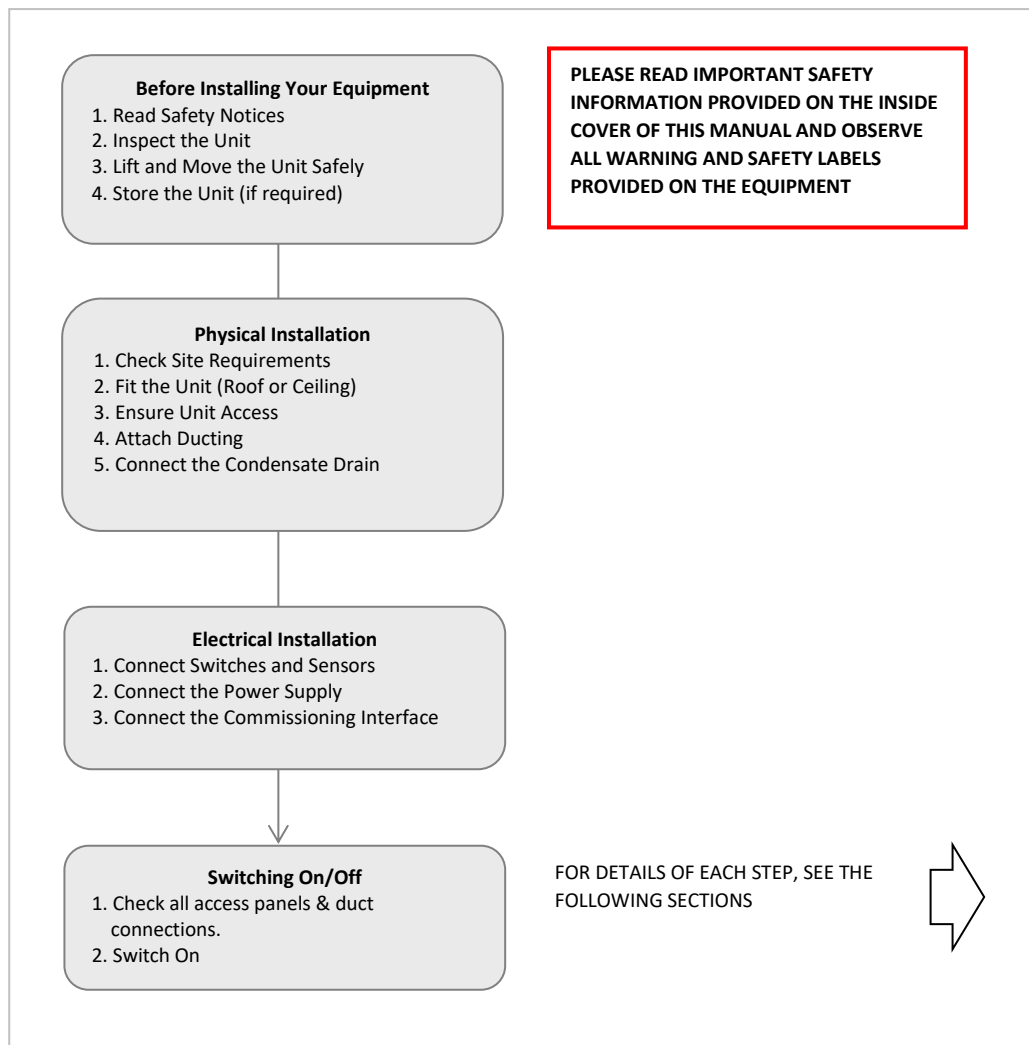

Figure 4 Installation Overview

Before Installing Your Equipment

Read Safety Notices

The equipment must be handled carefully and thoughtfully to prevent safety hazards and damage. Ensure the personnel designated to install the unit have the appropriate skills and knowledge.

Before commencing installation, please read and observe the safety notices given in the inside front cover of this manual.

Storing the Unit

The unit must be stored in clean, dry conditions and protected from damage. The unit should be inspected prior to install.

Inspect the Unit

The unit is supplied on a pallet, shrink-wrapped in polythene. When taking delivery of the unit, check the items delivered against the enclosed delivery note. Inspect the unit for damage in transit. If in doubt, contact Customer Services.

Locate the remote HMI and wall mounting kit contained in a poly bag within the Ambient End Inlet.

Lifting and Moving the Unit

This weight of the unit is stated on the rating label and detailed in the Technical Specification on page 9. Always use appropriate lifting techniques and appliances when moving heavy equipment. A forklift truck, crane or similar lifting gear is required to lift and move the unit. Suitably support the unit from the underneath, uniformly distributing the load across the chassis.

Physical Installation

Check Site Requirements

Before installing the unit, check that the physical and environmental conditions for the site meet, or exceed, the requirements detailed in the *Technical Specification* section of this manual.

DO NOT install these units in areas where the following may be present:

- Excessive oil or grease laden atmosphere.
- Corrosive or flammable gases, fluids or vapours.
- Possible obstructions that will restrict access for maintenance/removal.

Fitting the Unit (Roof or Ceiling)

The Apex units **MUST** be mounted horizontally ($\pm 0.5^\circ$) to ensure drainage of the condensate tray. **DO NOT** mount the unit vertically.

Do not use this unit as a support for any other equipment.

Always use the appropriate fixings, supports, studs and hangers; and ensure that the unit is firmly and safely located for the weight of the unit and associated attached equipment.

Unit Access

Ensure the unit is installed in such a way as to allow access to the control box, connectors and filters (see Minimum Maintenance Access Clearances on page 10). Check the dimensions of the unit detailed in the Technical Specification.

Maintenance access can be via different panels depending on the installation type (see Removal/Replacement of Parts on page 43).

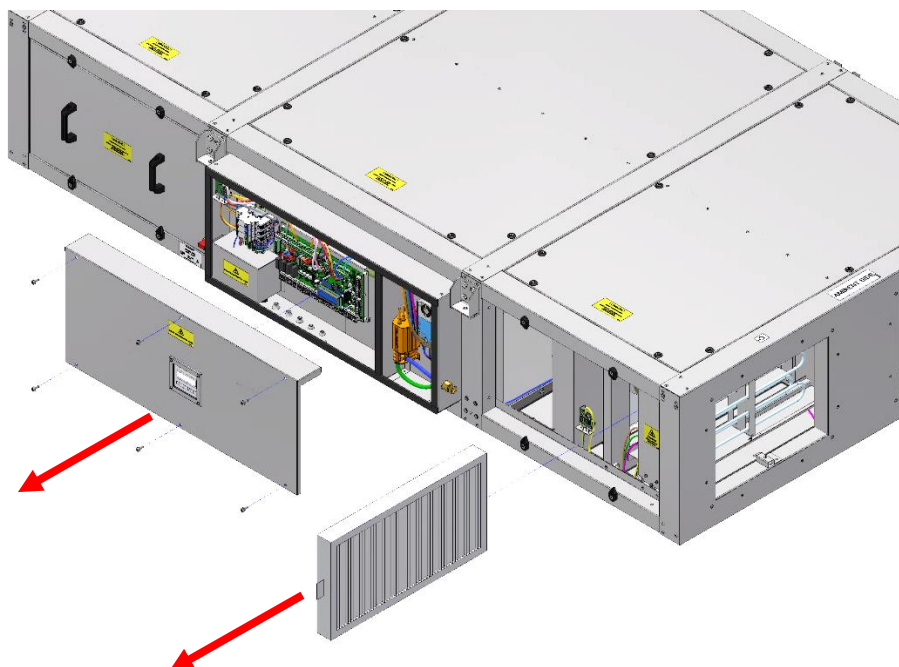

Figure 5: Control Panel & Filter Access

Ceiling Mounting

The unit provides four brackets which are supplied in the hanging configuration from which to suspended it. The unit is to be suspended using M10 rods, the mounting dimensions are shown in Unit Dimensions & Weights on page 9.

Ensure the drop rods & their attachment to the ceiling are of sufficient strength. **The brackets should NOT be moved to the lower position unless floor mounting.**

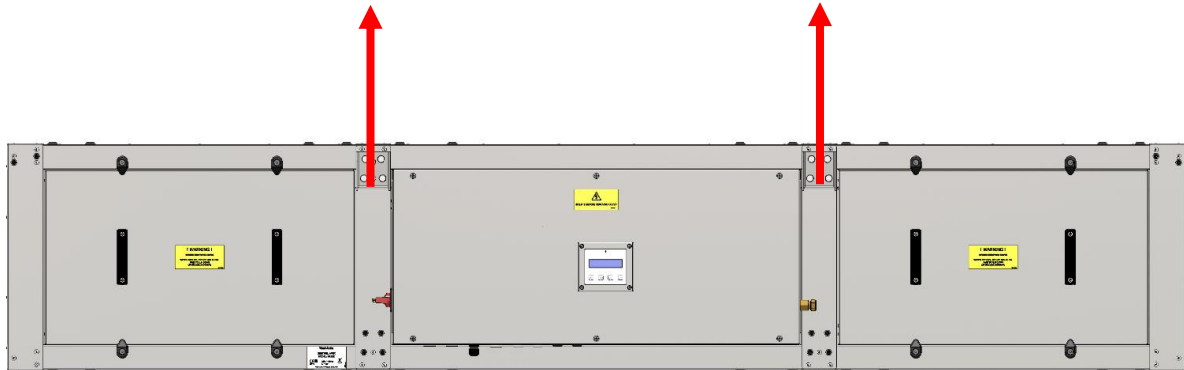

Figure 6: Ceiling Mounting

The Sentinel Apex Unit contains a heater, when installed at high level the unit shall be at least 1.8m from the floor.

Floor & Roof Mounting the Unit

The unit provides four brackets which are supplied in the hanging configuration. **For floor/roof mounting, the brackets MUST be moved to the lower position as shown in the image below.**

The suggested method for roof mounting is to support the unit on four blocks. The support blocks should provide 150 mm clearance between the unit and the roof, thereby allowing sufficient room for the fitting of the weatherproof cowls, as shown in the figure below. The blocks should be positioned directly below the support brackets provided for ceiling mounting.

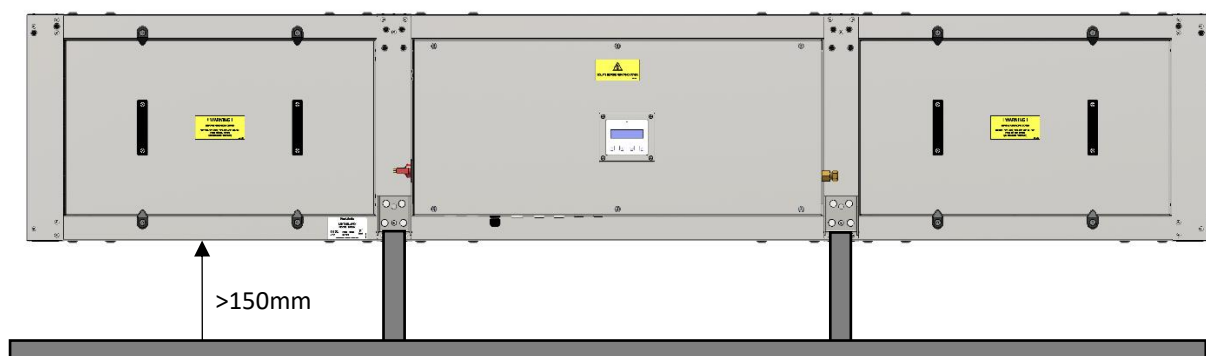

Figure 7: Roof Mounting

Note:

Any exposed ductwork must be insulated if the Apex unit is mounted on a roof or other external position.

Weather Roof

For roof mounted installations, the weather roof (see Appendix B: Options and Accessories on page 73) is required to achieve the appropriate IP rating. The **unit cannot be lifted** using the mounting brackets once the roof is installed.

1. Fix the roof mounting brackets at each corner using the supplied fixings.
2. Assemble the roof following the instructions provided with the kit.
3. After the unit is securely mounted in position, lift the assembled roof onto the unit, ensuring the additional flange on one side sits above the control box.
4. Align the fixings holes in the roof with the mounting brackets and install the fixings.

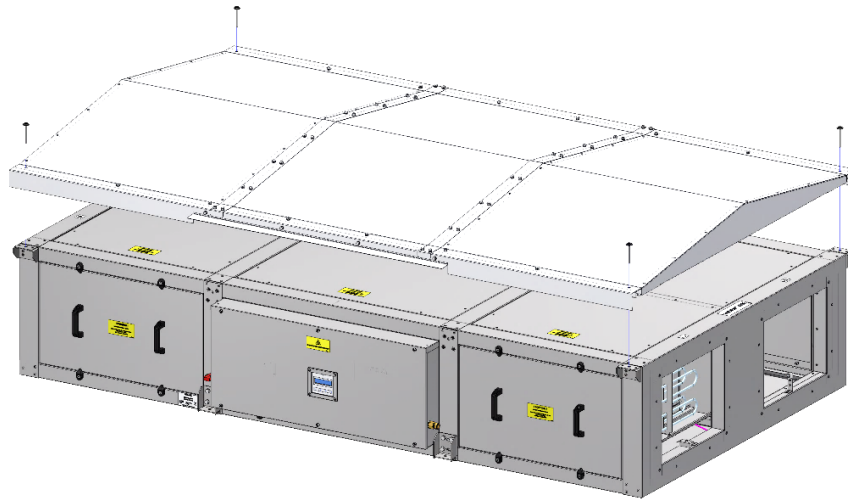

Figure 8: Weather Roof

Weatherproof Cowls

If required, weatherproof cowls (see Appendix B: Options and Accessories on page 73) can be fitted at the ambient end, pointing downwards as shown in the figure below. If required, ducting or attenuators can be fitted between the cowls and the unit.

Ensure the unit has been mounted with sufficient clearance available to fit the weatherproof cowls at the ambient end. Ensure a minimum distance below the cowl inlet of 150mm is available.

Position the cowls over each of the unit apertures, aligning the 4No. fixings holes. Secure each cowl using 4 x M6x26 bolts. Ensure flange is suitably sealed to the unit by use of a closed cell foam or suitable mastic sealant to maintain the internal pressure and prevent water ingress.

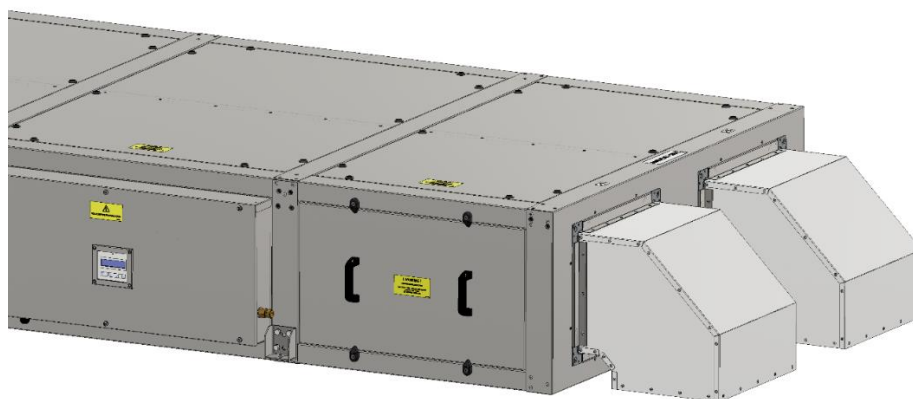

Figure 9: Weather Cowls

Attach Ducting



WARNING

IF THIS EQUIPMENT IS RUN WITHOUT DUCTING FITTED, THERE IS A POTENTIAL HAZARD FROM ROTATING EQUIPMENT AND HOT SURFACES THAT CAN BE REACHED DURING OPERATION.

Fit appropriate ducting to the unit in accordance with the supplied drawings for the building. Fit flexible connectors adjacent to the unit. Ensure they are taut. The unit provides rectangular ducting interfaces. Fit adapters as necessary to connect to ducting with a circular cross-section.

Condensate Outlet

The unit **MUST** be mounted horizontally to ensure functionality of the condensate system. Use a 10 mm copper pipe connected to the condensate outlet of the unit. The condensate pipe should be directed to a suitable discharge point such as the buildings wastewater system. The condensate discharge must be no more than 8m above the unit. If the pipe is installed in an area which could freeze, insulation or a proprietary frost pipe heater should be fitted.

Electrical Installation

Connect Switches & Sensors

Connect any required switches and/or sensors as recommended by the system designer in the supplied drawings.

A 24 V_{dc} supply is provided for powering sensors and external peripherals (e.g. wall-mount remote HMI).

Analogue signal returns must be 0-10 V dc with common ground for the instrument and cable screen at the control board.

The terminal connections provided by the Main Controller PCB for connecting to switches, sensors, etc., are shown below. Other terminals are connected as required at the factory. **DO NOT** disconnect any factory fitted connections.

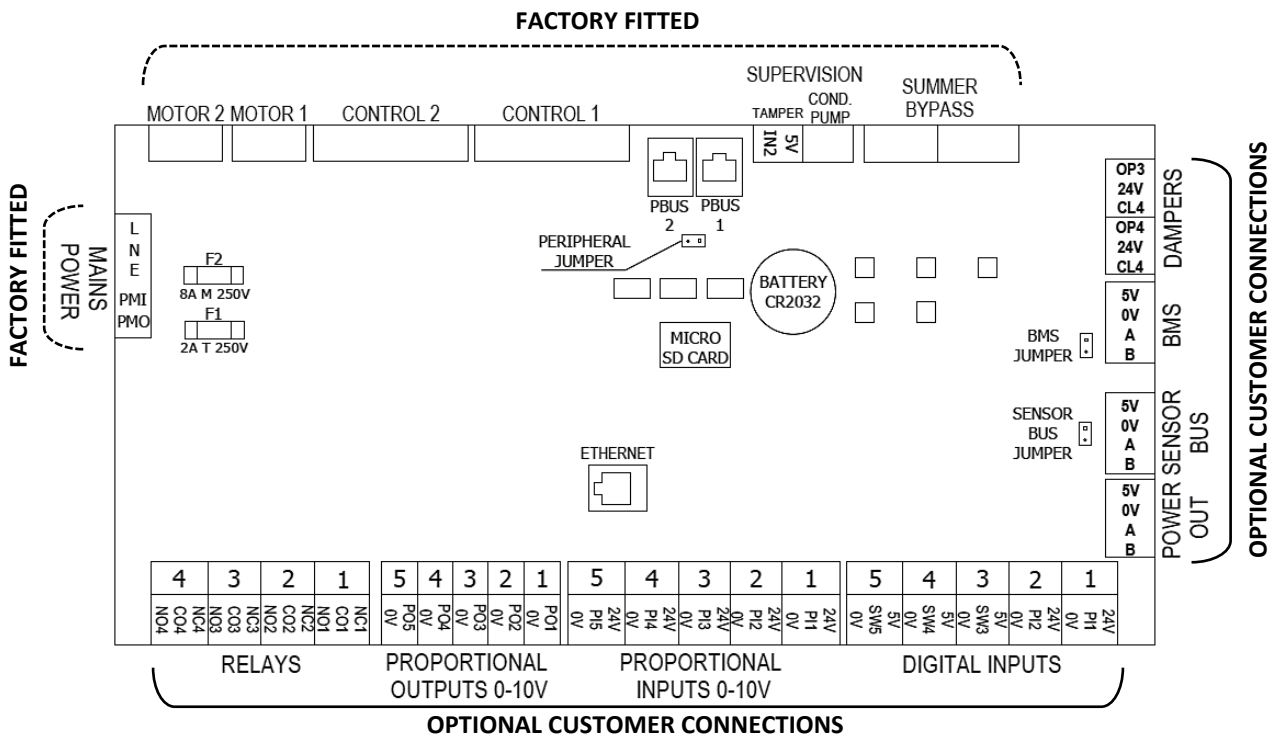

Figure 10: Main Controller PCB Terminal Connections

Connect the Power Supply



WARNINGS

1. MAINS SUPPLY VOLTAGES (220-240 V AC) ARE PRESENT IN THIS EQUIPMENT WHICH MAY CAUSE DEATH OR SERIOUS INJURY BY ELECTRIC SHOCK. ONLY A QUALIFIED ELECTRICIAN OR INSTALLER SHOULD CONNECT THE POWER SUPPLY TO THIS UNIT.
2. THIS UNIT MUST BE CORRECTLY EARTHED IN ORDER TO PROVIDE OVERCURRENT AND EARTH FAULT PROTECTION.
3. DO NOT OVERLOAD WALL OUTLETS AND EXTENSION CABLES AS THIS MAY RESULT IN A RISK OF FIRE OR ELECTRIC SHOCK.
4. ENSURE THE UNIT ISOLATOR IS SET TO OFF AND LOCKED IN POSITION BEFORE REMOVING THE UNIT COVERS.

Refer to the Technical Specification section of this document for the voltage, current and fusing information relevant to this product.

These units are designed for operation from 220-240 V ac source. By default, the units are configured to run from a single-phase alternating current source, but can be re-configured for two or three single phases from the same phase which allows the current to be distributed for the heaters, fans and unit through separate outlets and cables, if required.

Wiring to the unit should be routed via a six-pole isolating switch (in accordance with local electrical wiring regulations) adjacent to the unit or taken from the distribution board.

1. Ensure that the local AC power supply is isolated at the distribution board before connecting the supply cable.
2. Ensure the correct fuse type, or circuit breaker has been fitted to the ac power input supply.
3. A method of disconnection incorporated in the fixed wiring is to be provided.
4. To prevent the equipment being accidentally switched on while you are away from it the unit isolator may be locked in position. Pull out the yellow inner section of the isolator switch to lock the isolator in position, revealing a hole through which a padlock, or other lockable device, may be inserted.
5. Remove the unit Control Panel cover by removing the six securing screws (see Panel Removal/Replacement section of this Manual).
6. Remove the mains shield by removing three screws to reveal the installer connections on the DIN rail.

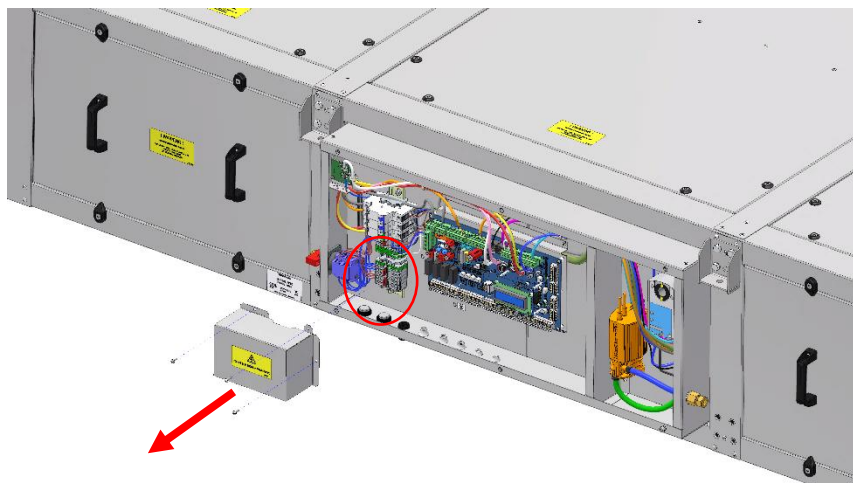

7. Route the power cable through either the 20mm or 16mm hole into the control box, beneath the DIN rail. Fitting an appropriately sized M20 or M16 gland.
8. Connect the power supply to the DIN rail. See configuration options on the next page.

One 230VAC 50Hz Single Phase Configuration

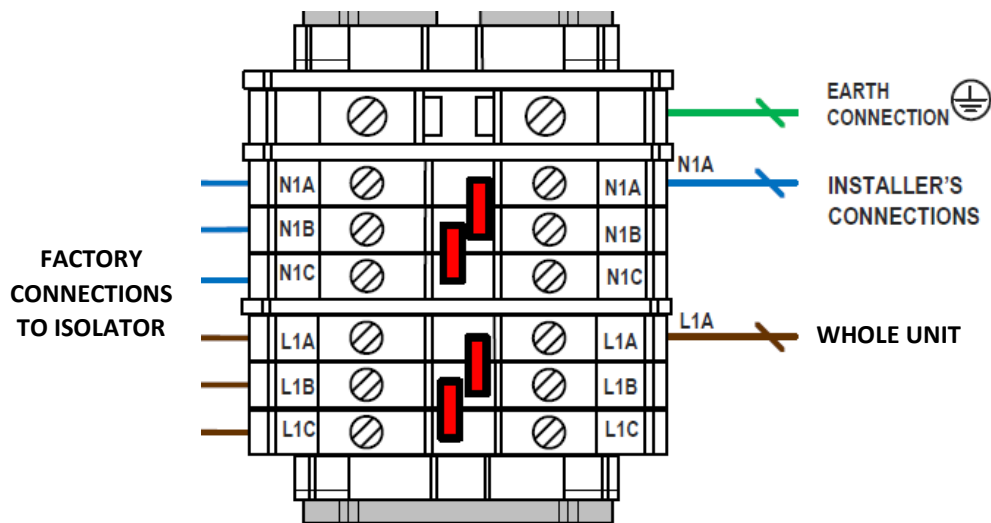

Two 230VAC 50Hz Single Phase Configuration – All same phase

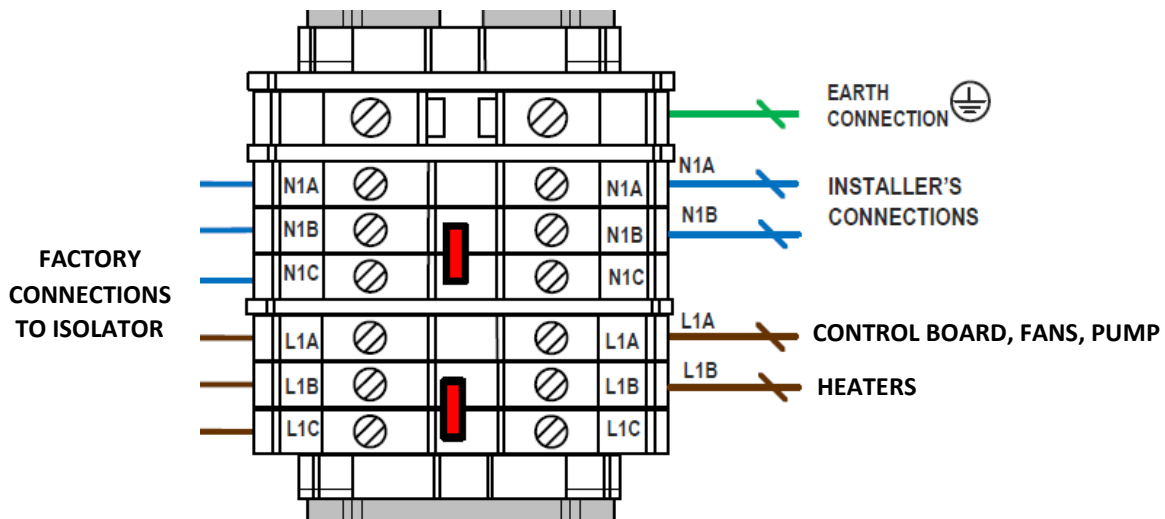

Three 230VAC 50Hz Single Phase Configuration – All same Phase

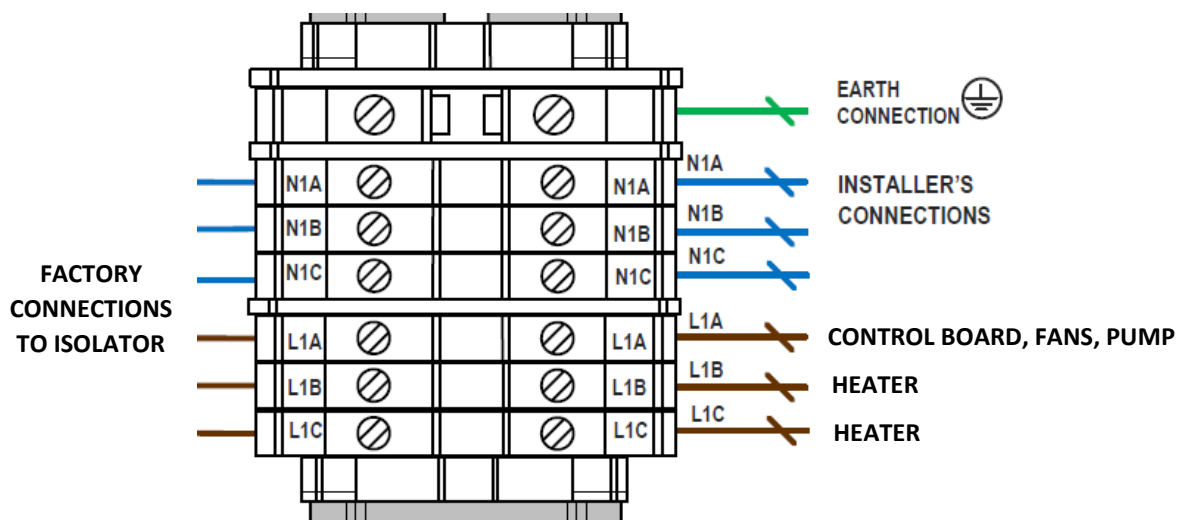

Note:

1. All units will be supplied with the DIN rail configured for single phase connection.
2. Use fixed wiring with rigid conductors. **DO NOT** use flexible cable.



WARNING

THE UNIT AND ANCILLARY CONTROL EQUIPMENT MUST BE ISOLATED FROM THE POWER SUPPLY DURING ANY MAINTENANCE AND WHEN FITTING THIS CONTROL MODULE.

Connect the Remote HMI/Commissioning Interface

The remote HMI and wall mounting kit is supplied with all Apex units and designed so that the MVHR controller unit can be operated remotely. The kit is designed to fit a single gang flush mount back-box of 25mm depth (min.). The kit is supplied with a 15m lead.

1. Site the back box for the Wall Mounting Kit at a height of 1.5m from the floor and within the distance of a 15m cable run from the MVHR unit. Do not extend the cable provided.
2. Route the cable provided from the back box to the MVHR unit entering through one of the available grommets on the underside of the control box. Avoid routing the cable alongside mains power cable.
3. Using a flat head screwdriver, separate the display and backplate by pushing the tab at the bottom.
4. Fit the signal wires to terminal 1 & 2 and fit power wires to terminals GND (-) & 24VDC (+) on the mounting plate. **Terminal 3 is unused.**
5. Screw the backplate to the backbox, then clip the HMI controller to the backplate.

Mounting Plate PCBA Connections

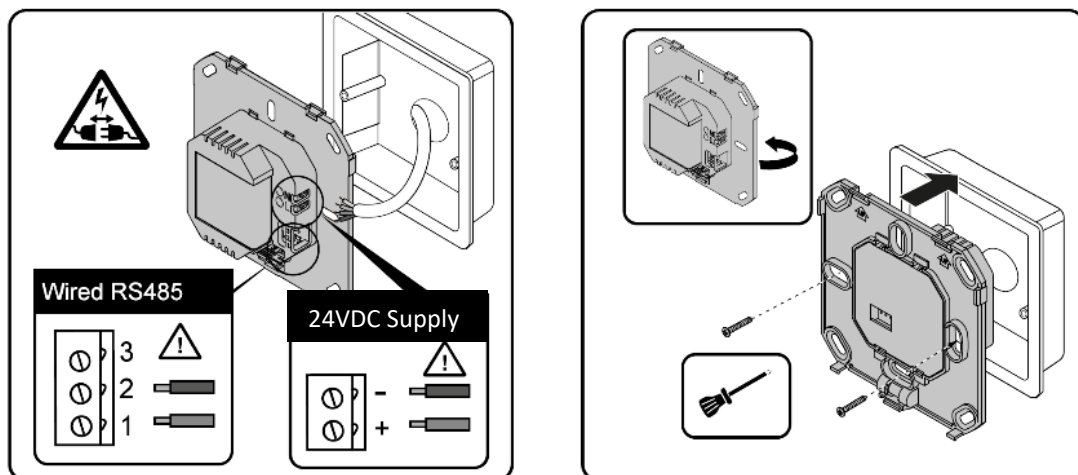

Terminal	Wiring Colour
GND (-)	Brown/White
24VDC (+)	Brown
3	N/C
2 (RS485 -B)	Blue/White
1 (RS485 +A)	Blue

Operating and Monitoring

Switching On/Off

Switch On

The following procedure assumes that all necessary installation actions have been performed in accordance with the instructions given in this section of the manual.

To switch the unit on:

1. Ensure that all removable panels are fitted and properly secured (see Panel Removal/Replacement see 43)
2. Switch on the power at the mains outlet feeding the Apex unit.
3. At the unit's cable entry panel, turn the isolator switch to position 1 (ON).
4. Observe the Commissioning Interface on the onboard HMI. After a 10 second delay, the Commissioning Interface displays a start-up screen. The start-up screen briefly displays model and software version number (a), followed by the language setting screen (b), and then the normal airflow screen (c). The fans will ramp up to the normal speed setting.

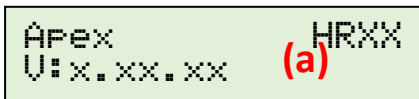

Apex HRXX
U: x.xx.xx (a)

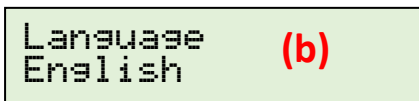

Language (b)
English

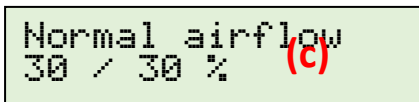

Normal airflow (c)
30 / 30 %

5. Ensure that the Status LED on the Commissioning Interface is blinking white, indicating that the unit is operating normally.

Switch Off

To switch the unit off:

- At the unit's cable entry panel, turn the isolator switch to position 0 (OFF).
- When carrying out work or maintenance inside the unit, switch off the power at the mains outlet supplying the unit before removing the covers.
- To prevent the equipment being accidentally switched on, the unit isolator may be locked in position. Pull out the yellow inner section of the isolator switch to lock the isolator in position, revealing a hole through which a padlock, or other lockable device, may be inserted.



WARNING

WITH THE ONBOARD ISOLATOR SWITCHED OFF, THERE IS POTENTIAL ACCESS TO LIVE CONNECTIONS IF DIN RAIL COVER IS REMOVED. ALWAYS FULLY ISOLATE THE MAINS SUPPLY TO THE UNIT BEFORE REMOVAL OF THE DIN RAIL COVER.

Overview

The instructions in this section are intended to provide configuration and operation information for setting up the equipment via the onboard HMI, remote HMI, or App. In the event of problems, see the Troubleshooting Section of this Manual.

Follow good practice when commissioning the unit. Ensure that the system is installed according to the system designer's intent incorporating any acoustic ducting, that all joints are airtight, ducting is well supported, bends are avoided close to vents, and that the vent valves are fully open at the start of the commissioning process.

It is recommended that commissioning of the unit is done via the App (See the Smart Device Pairing and App Download section of this Manual) for ease and to have full access to all details and settings.

Onboard HMI

All units come fitted with an onboard HMI with 2-line LCD and status LED. The onboard HMI and status LED can be viewed through the Perspex window on the control box.

Removal of the window is required to operate the push buttons.

Remove and retain 4No fixings to remove the metal shroud and Perspex window. On refitting, ensure the window is fitted with its gasket towards the unit to ensure appropriate sealing.

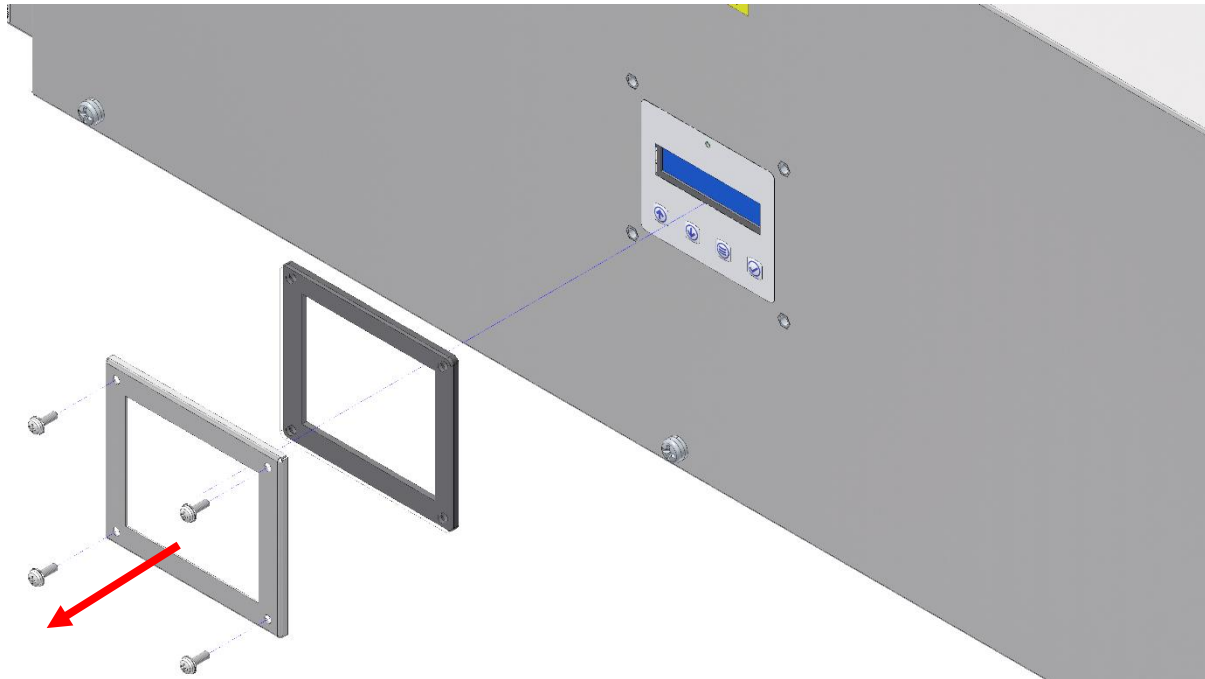

Display Overview

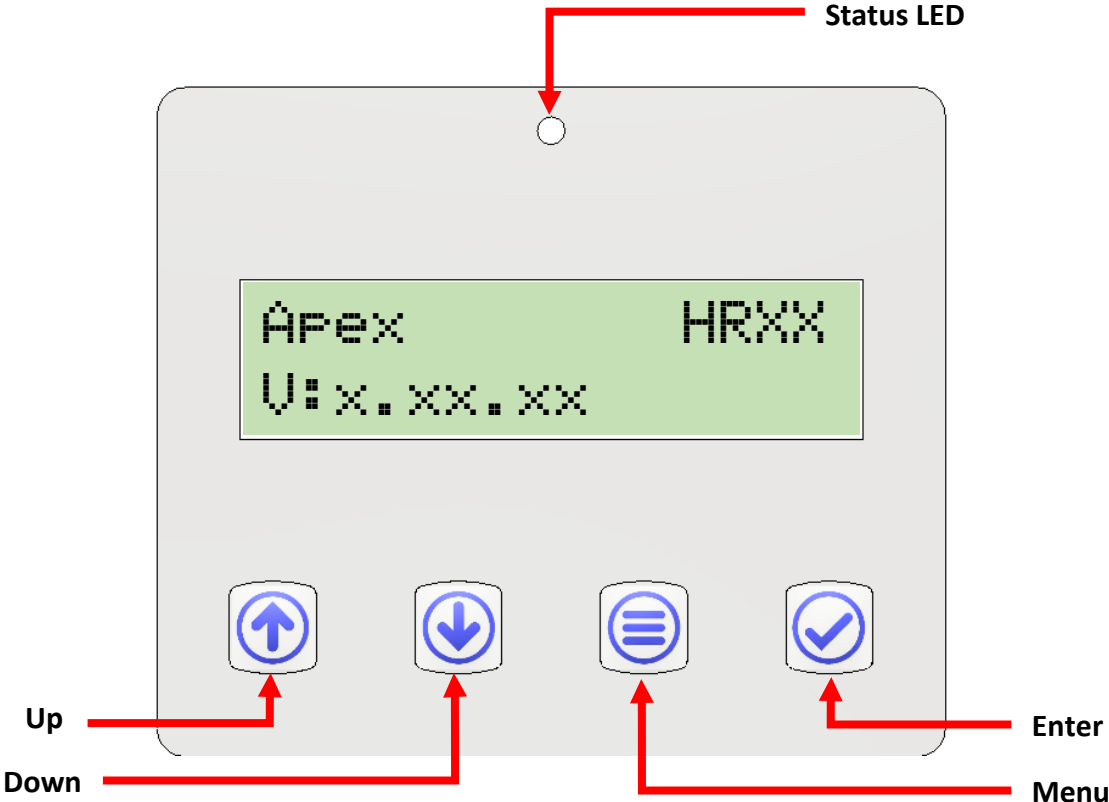

Push Buttons

Four push buttons on the onboard HMI provide controls for configuring and monitoring the unit. Removal of the window is required to operate the push buttons.

Table 1: Onboard HMI Push Buttons

Push-button	Function
Up	Press to scroll up the menu or to increase a parameter value. Press and hold for fast response.
Down	Press to scroll down the menu or to decrease a parameter value. Press and hold for fast response.
Menu	Press to move to the next menu item.
Enter	Press to enter the menu item and adjust settings.

Status LED

A status LED indicates the presence of a fault see the **Trouble Shooting Section** for details.

On-board User Menu

The below diagram shows the menu structure accessible via the onboard HMI.

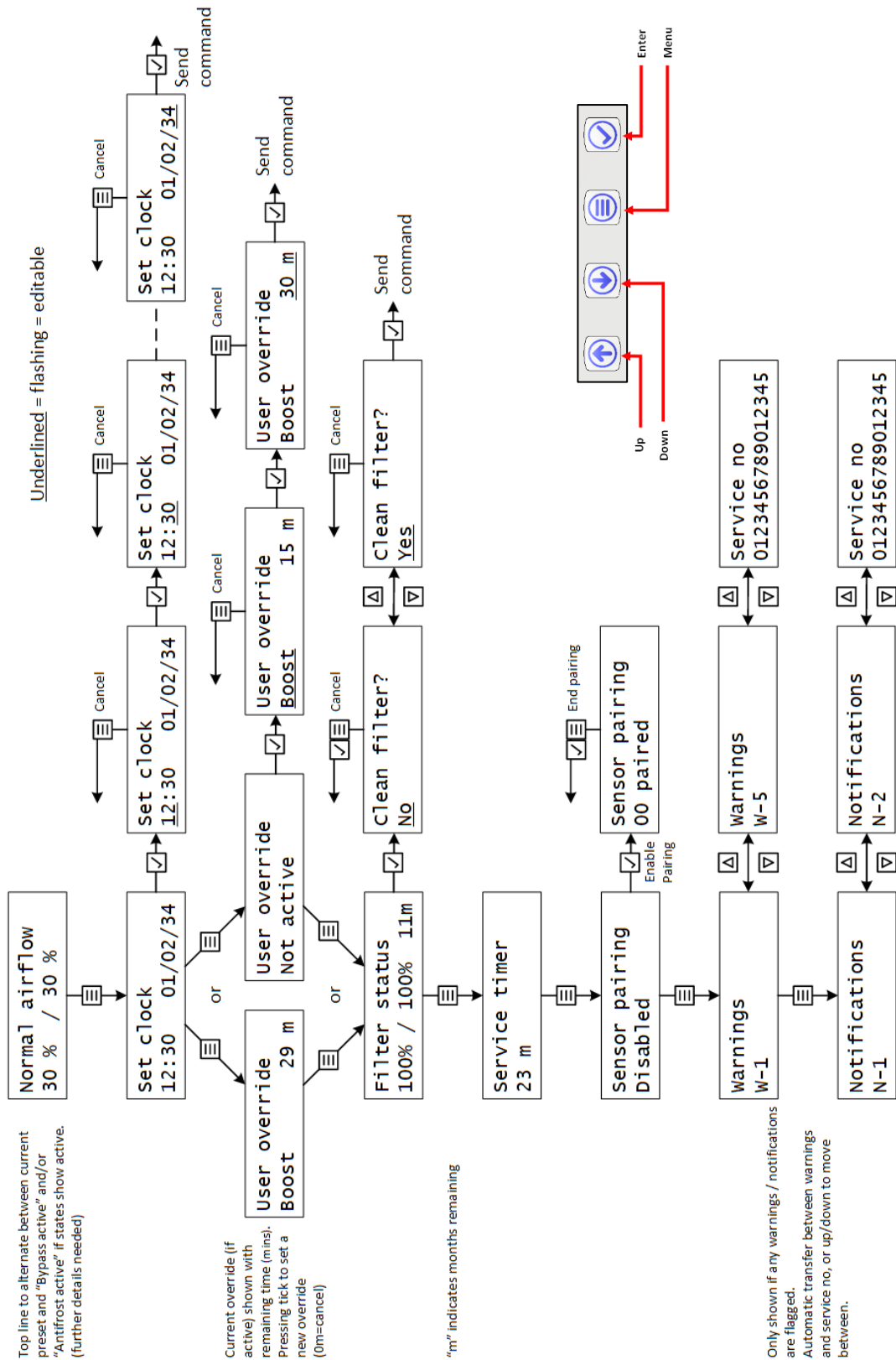

Commissioning Menu

The below diagram shows the commissioning menu structure accessible via the onboard HMI.

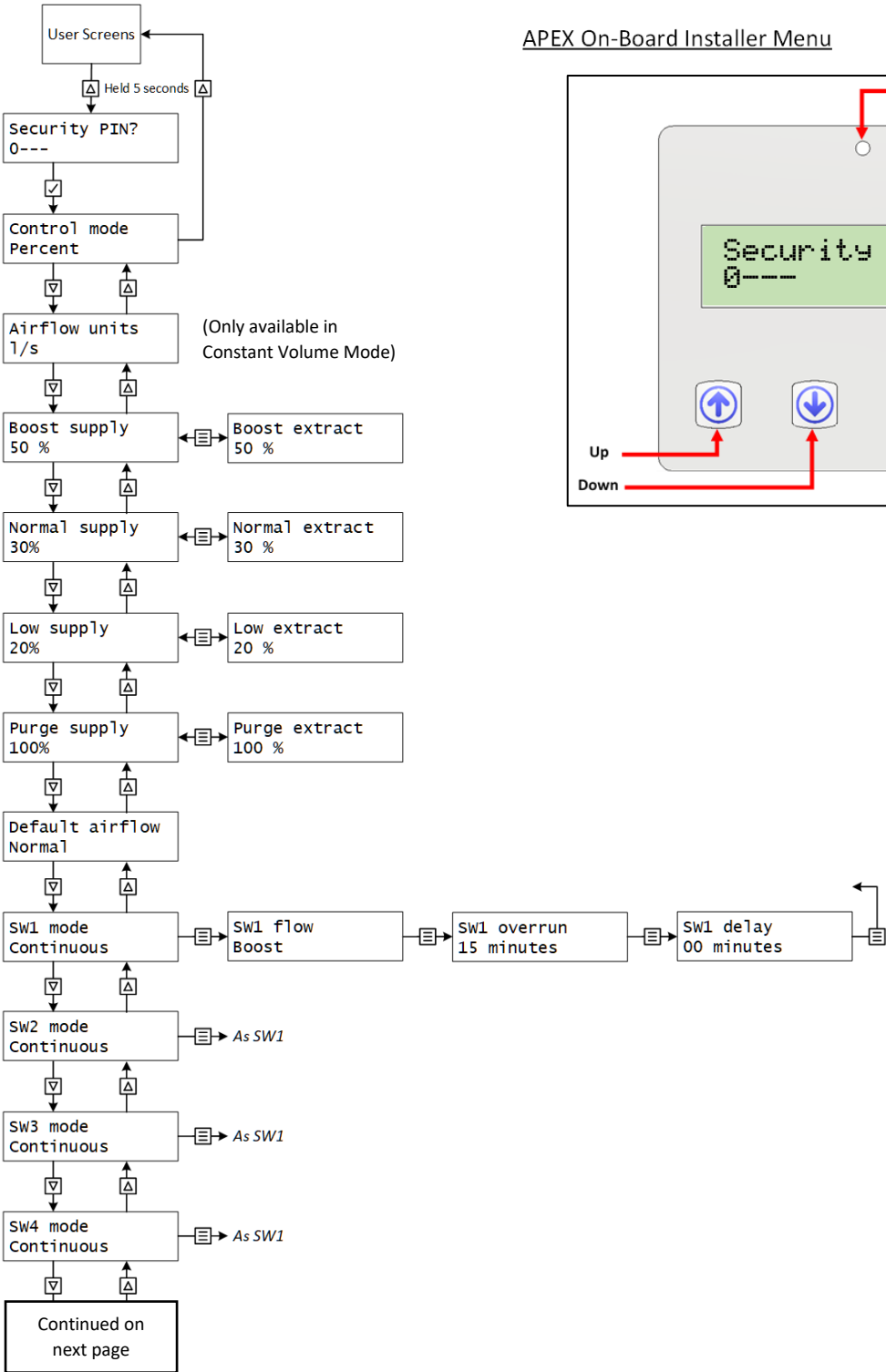

APEX On-Board Installer Menu

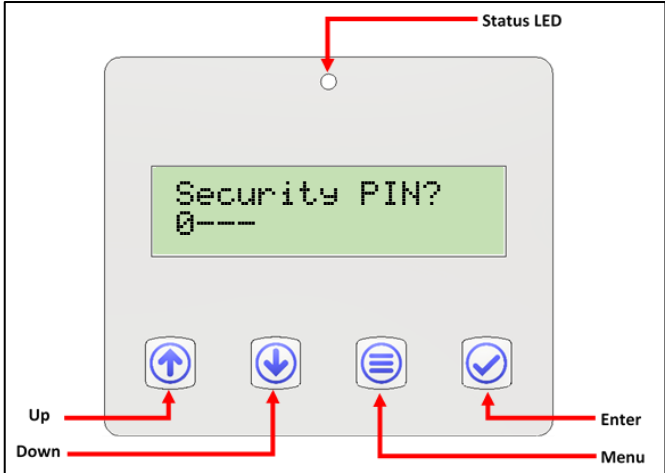

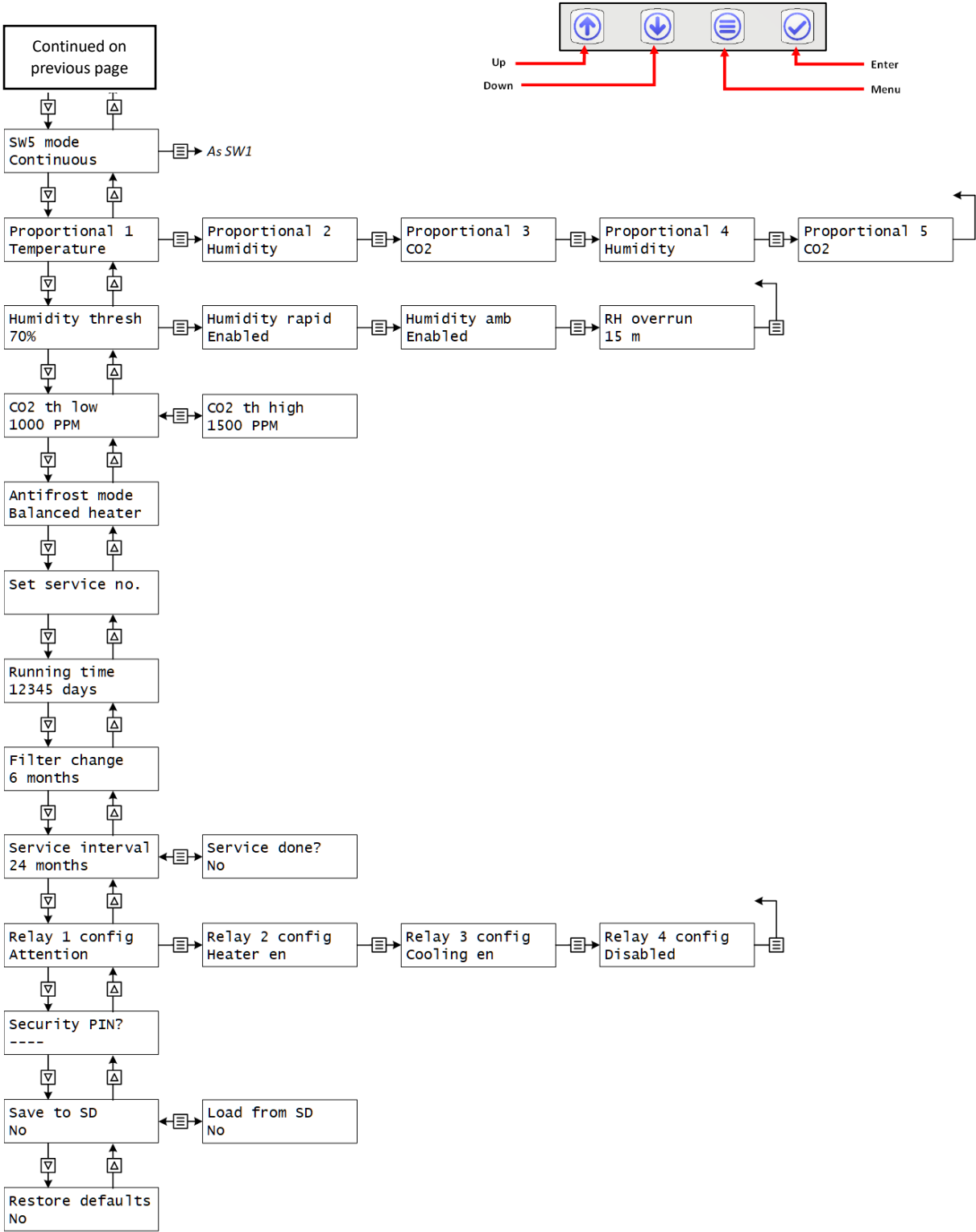

Remote HMI



THE REMOTE HMI AND WALL MOUNTING KIT IS DESIGNED SO THAT THE MVHR CONTROLLER CAN BE OPERATED REMOTELY. FOR CONNECTION DETAILS, SEE PAGE 18

WARNING

THE UNIT AND ANCILLARY CONTROL EQUIPMENT MUST BE ISOLATED FROM THE POWER SUPPLY DURING ANY MAINTENANCE AND WHEN FITTING THIS CONTROL MODULE.

Connect the Remote HMI/Commissioning Interface/Initialisation/Loading Screen

Firmware version
 1 – HMI
 2 – Bluetooth & WiFi
 3 – PCB Main Board

The Initialization can take 2 minutes to complete.

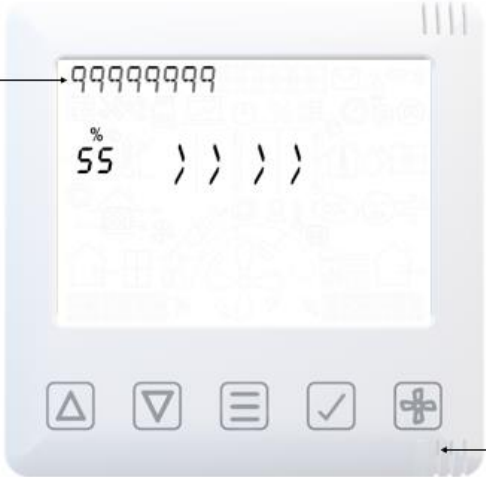

Primary Devices

Idle White LED indicates primary HMI, this device supports Bluetooth/Wifi connection (see Smart Device Pairing)

Additional Devices (If purchased)

Idle Green LED indicates secondary HMI device, no Bluetooth/Wifi support. (Refer to Pairing Sensors)

Serial number on initialisation

Serial number displayed after initialization is complete.

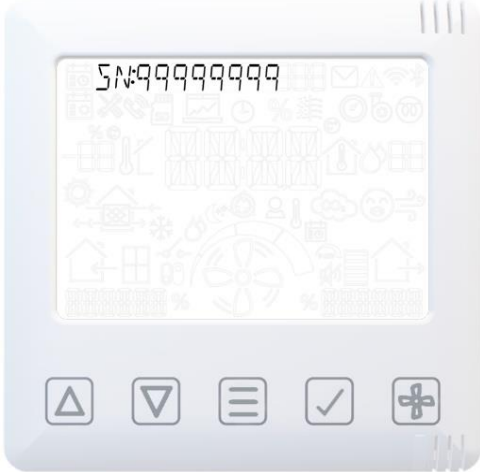

Display Overview – Home screen

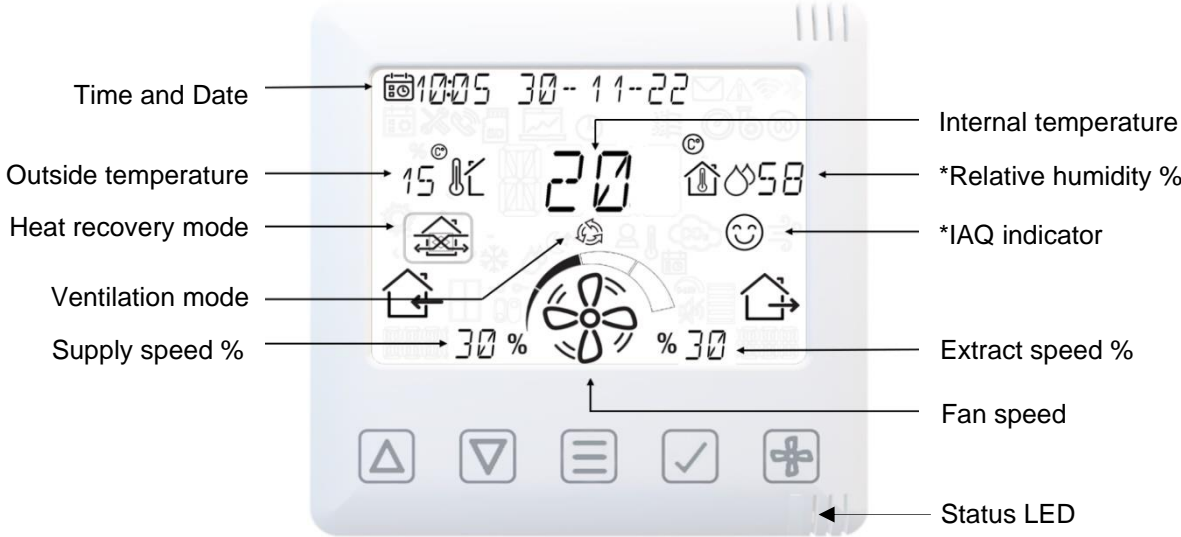

*Symbol only displayed if relevant sensor is connected.

Display Overview – Home user menu

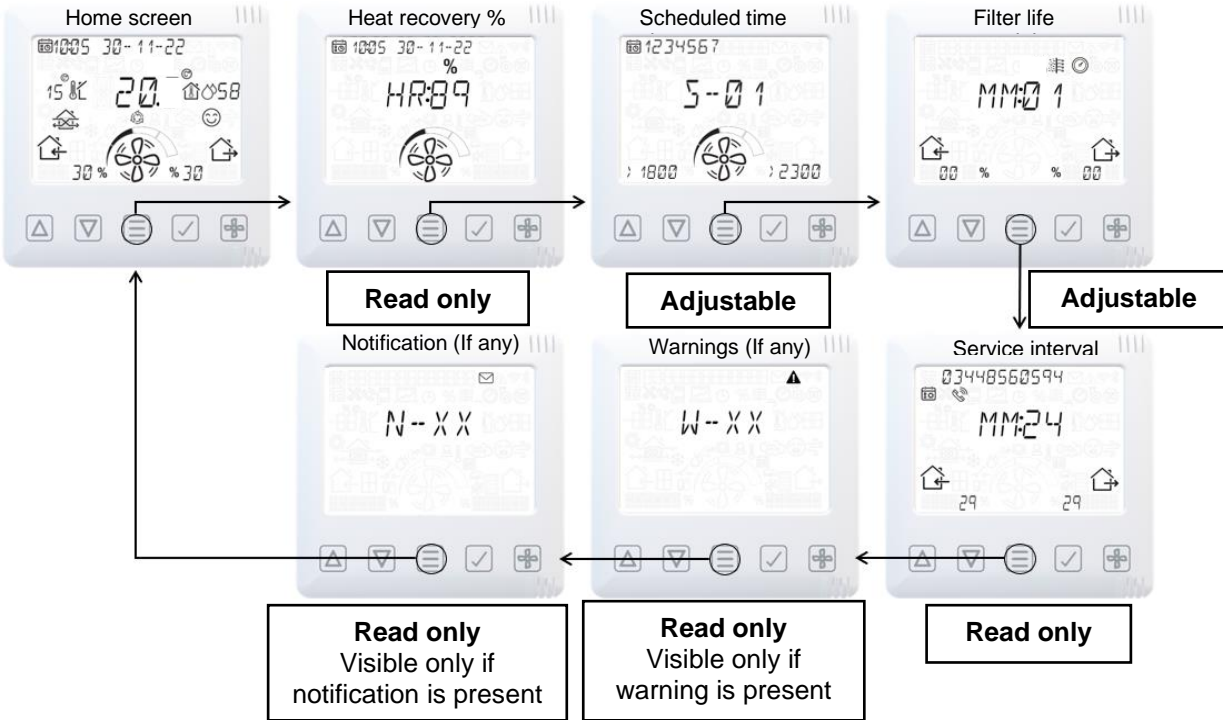

Display Overview – Additional icons

Datalogger				Notification
Clock & Countdown Timer				Warning
Summer bypass active				Wi-fi
Anti-frost Active				Bluetooth
Filter				Pressure icon
				Pre-heater

Display Overview – Mode indicators

Auto Mode				User Override
Humidity Override				Temperature Override
Switch Override				Schedule Override
LS Override				0-10V Override
CO2 Override				Silent Hours

Display Overview – Indoor air quality monitor

In conjunction with and linked to:

- CO2
- TVOC
- Relative humidity

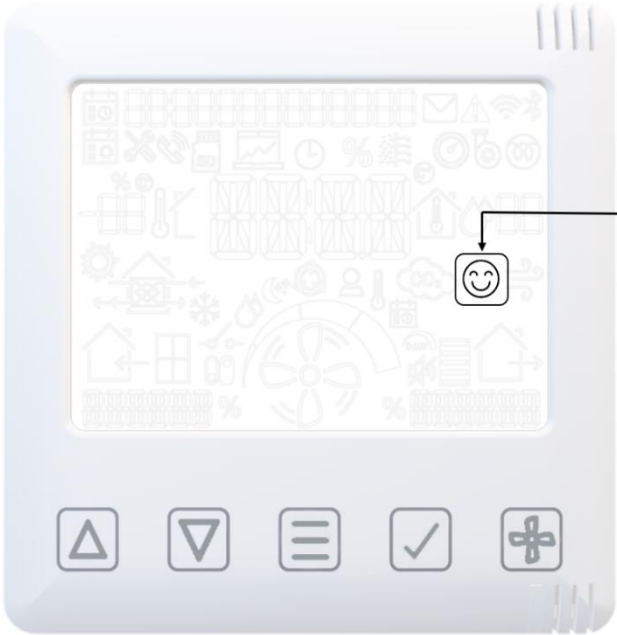

- IAQ
- No additional demand
 - Proportional demand
 - Full boost operation

Display Overview – Heat Recovery mode

- Heat Recovery Mode
- Bypass
 - Balance
 - Imbalance

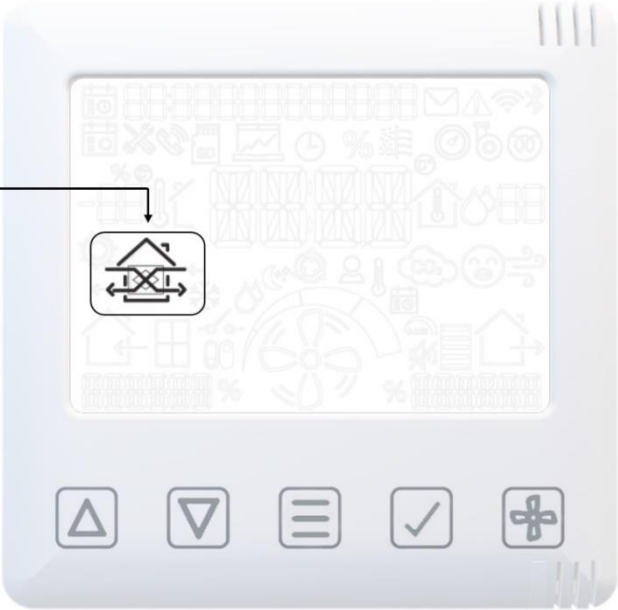

Smart Device Pairing and App Download

To be utilized in conjunction with App Instructions

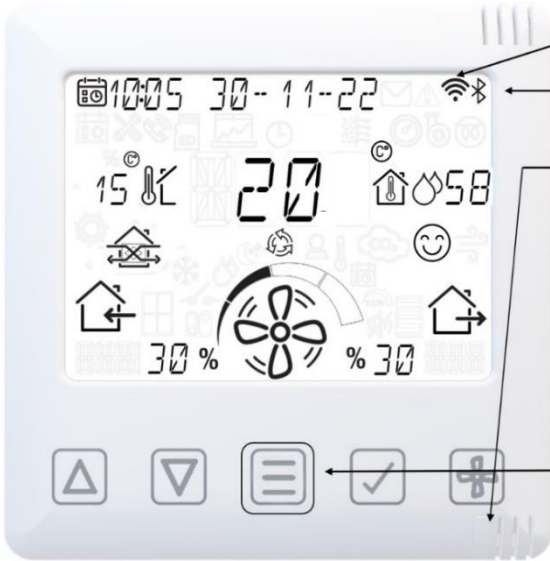





- WiFi icon will appear
- Bluetooth icon will appear
- Flashing Blue LED = Pairing/Enabled.
Solid Blue LED = User Connected/Authenticated.
- Press and hold for 8 seconds, until Blue LED is

The App allows the user easy access to commissioning, configuration, direct monitoring and control of the MVHR unit, using a smart phone or tablet with the **Vent-Axia Connect App**, available from the iTunes Store or on Google Play.



Pairing sensors





To pair the unit with a wired or wireless sensor:

- Press the **MENU**  button to turn on the display.
- Press and hold the **MENU**  button until the LED illuminates solid White.
- Release the **MENU**  button, the LED will flash White to indicate that it is in pairing mode. The unit will remain in pairing mode for 5 minutes, or until the **MENU**  button is pressed again.
- Activate the pairing function on the sensor to be paired (see the instructions supplied with the sensor).
- When a sensor is paired the total number of paired devices is displayed on the unit (P-XX).

For sensor options, see *Appendix B: Options and Accessories* of this Manual.

Removing sensors

To remove paired sensors, the unit must be reset. Caution, this will reset all values back to factory default.

- Press the **MENU**  button to turn on the display.
- Press and hold the **MENU**  button until the LED illuminates solid Red.
- Release the **MENU**  button, the LED will stay Red.
- Pressing the **MENU**  button again will confirm the reset command. If a reset is not wanted, leave the unit until the command times out and the LED turns off.

Speed Override

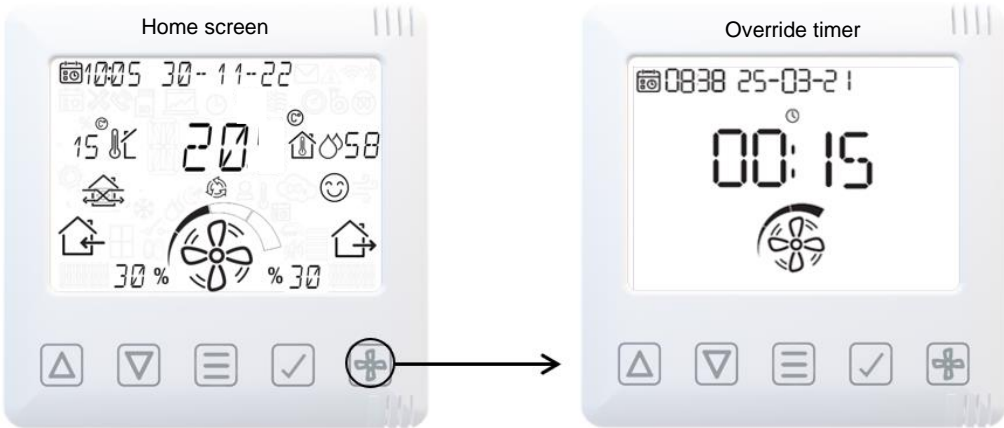

- Increase Timer
- Decrease Timer
- Change Fan Speed – Low, Normal, Boost, Purge
- Confirm Timer



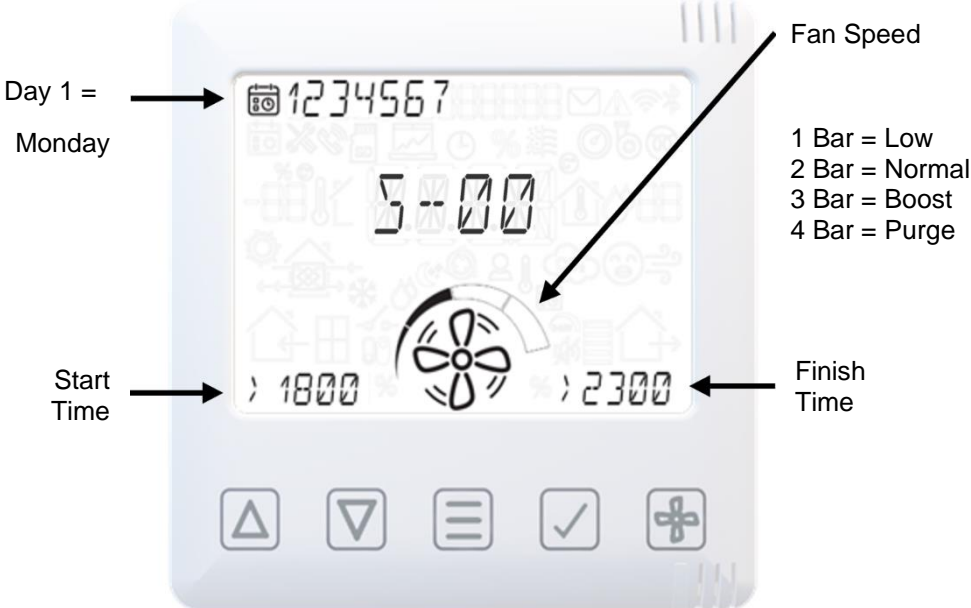

Schedule

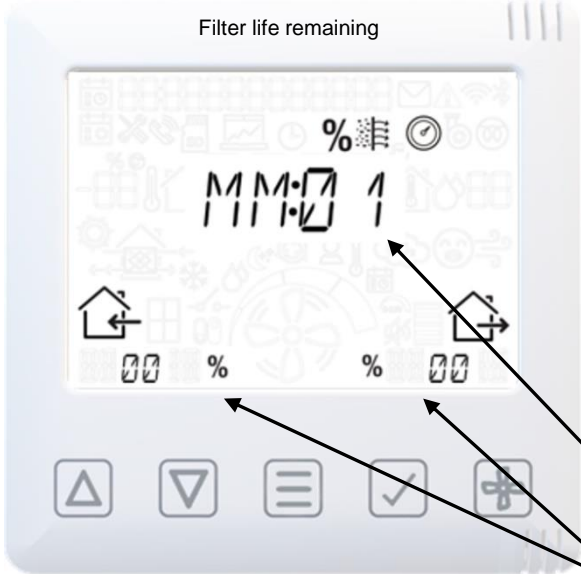

- Press 2 x from Home Screen to enter scheduling.
- Enter edit mode/Confirm Selection.
- Move between existing schedules and adjust schedule times/days in edit mode
- Move between existing schedules and adjust schedule times/days in edit mode
- Change Fan Speed – Low, Normal, Boost, Purge when flashing.

Filter Reset



-  Press 3 x from Home Screen to enter filter screen.
-  Enter Reset/Confirm Selection.
-  Change service duration for filters: 3, 6 or 12 months.
- 
- Months remaining, will indicate when filters need replacing/cleaning.
- Models with filter pressure sensors fitted, filter life is indicated by % block values.

Warning Screen

Please see the *Trouble Shooting* Section of this Manual for warning codes.



Important: This screen is only visible if a warning or fault is known.

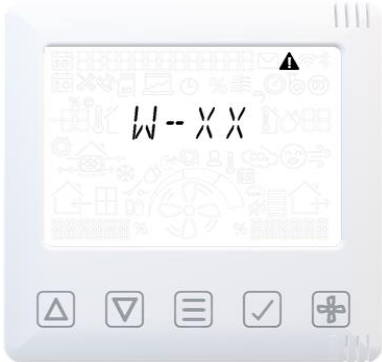

Service Interval Remaining

Months remaining before service is due.

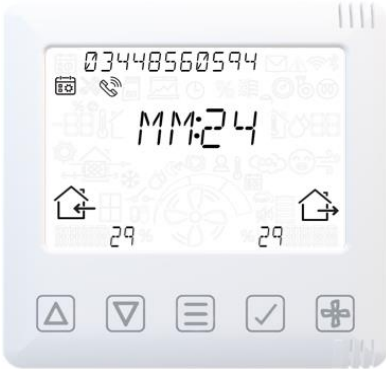

Notifications if any

Please see the *Trouble Shooting* Section of this Manual for notification codes.







Important: This screen is only visible if any notification is present.

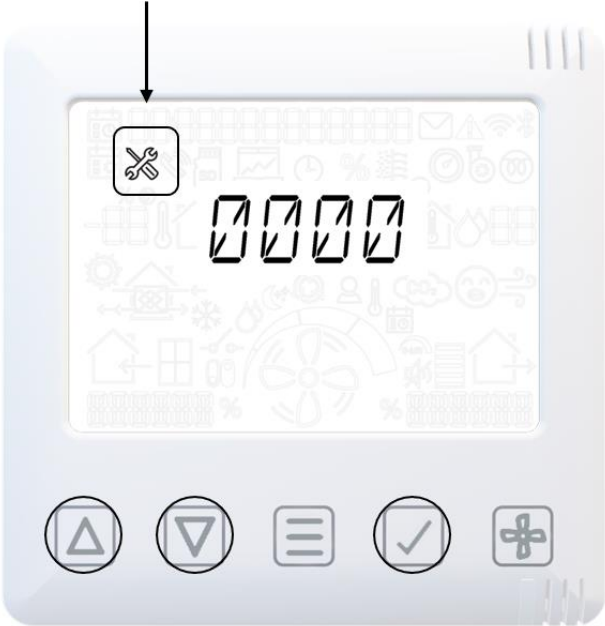

Engineer menu

Engineering mode



-  Press and hold for 3 seconds to exit or enter the Engineer Menu.
-  Use up and down to adjust each pin number and press  to confirm each number and enter Engineer settings.
-  number and enter Engineer settings.

Engineer menu – Overview

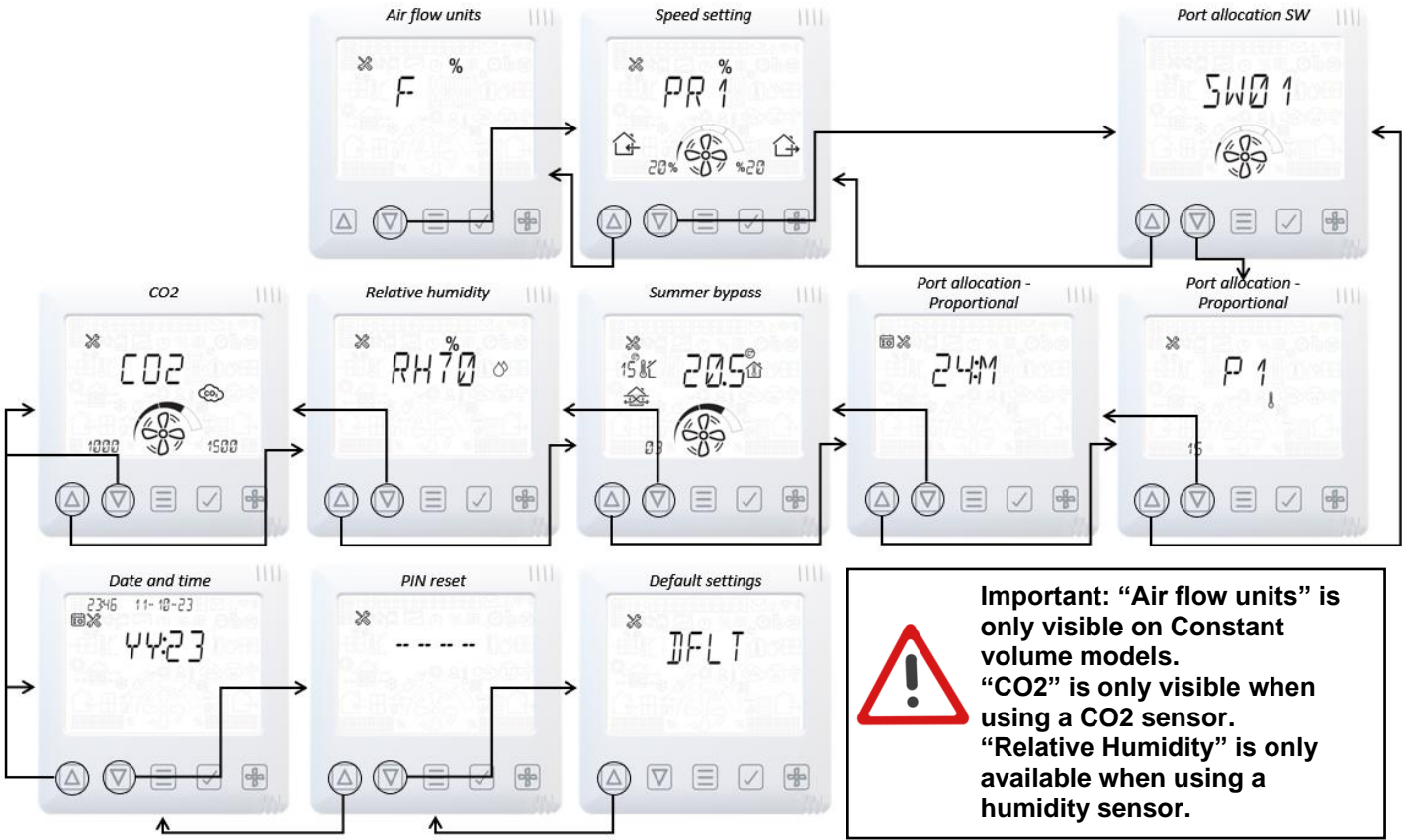

Engineer menu – Airflow units

User can select preferred airflow units.

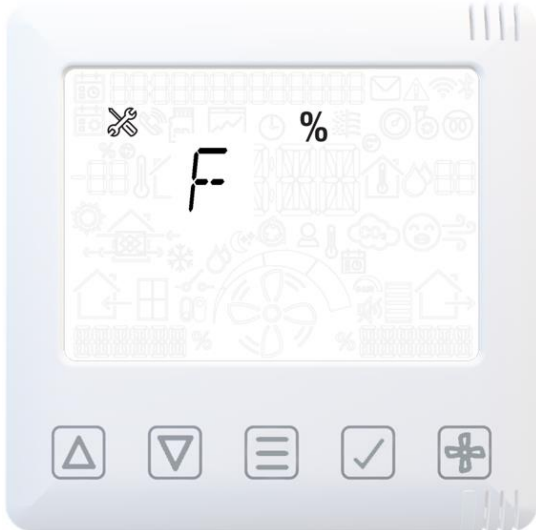

- Enter Menu/Confirm Selection
- Alternate measures
L/S M3/H C-E

This is only visible and used on Constant volume models.

Engineer menu – Airflow speed setting



- Select PR1-4
- Enter/Confirm Selection
- Adjust flow rate as % pr l/s

PR1 = Low Speed 20% Default



PR2 = Normal Speed 30% Default



PR3 = Boost Speed 50% Default



MVHR unit will run at speed indicated on this screen to aid commissioning.

% will be displayed as l/s for Constant volume.

Engineer menu – Port allocation SW



- Change Fan Speed – Low, Normal, Boost,

- Enter/Confirm
- Change Port Switch SW01 to SW05

Engineer menu – Proportional control

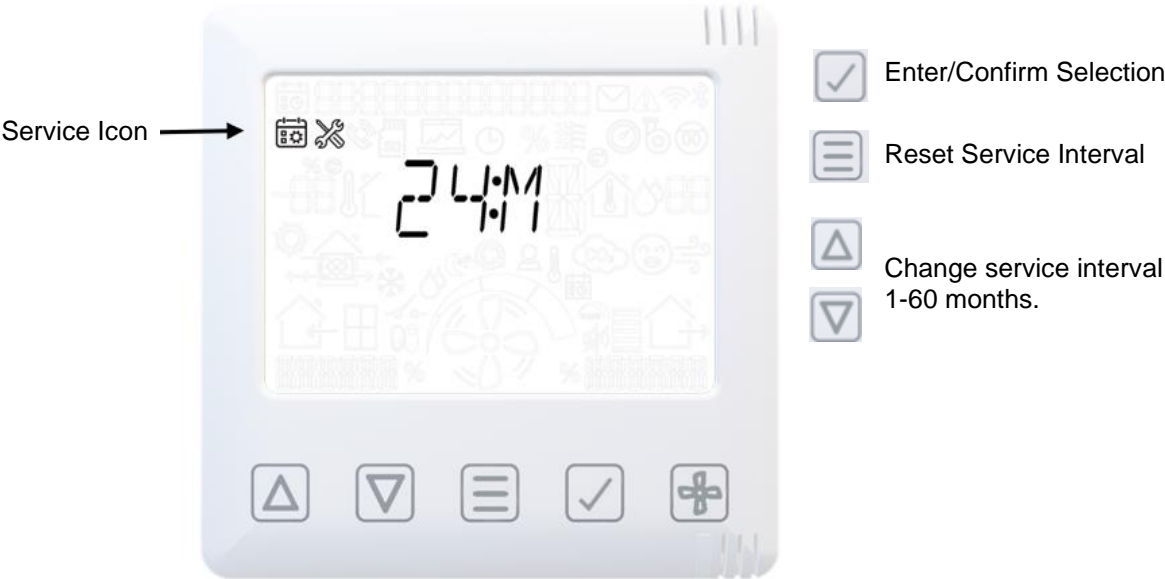

- Press Once for Zonal Selection
- Press twice for Control method Selection
- Change Proportional Control P1 or P2
- Change Zonal Control 1-15
or
- Control Method Temperature, Humidity,
0-10V, CO2

Engineer menu – Service Intervals



Engineer menu – Summer Bypass

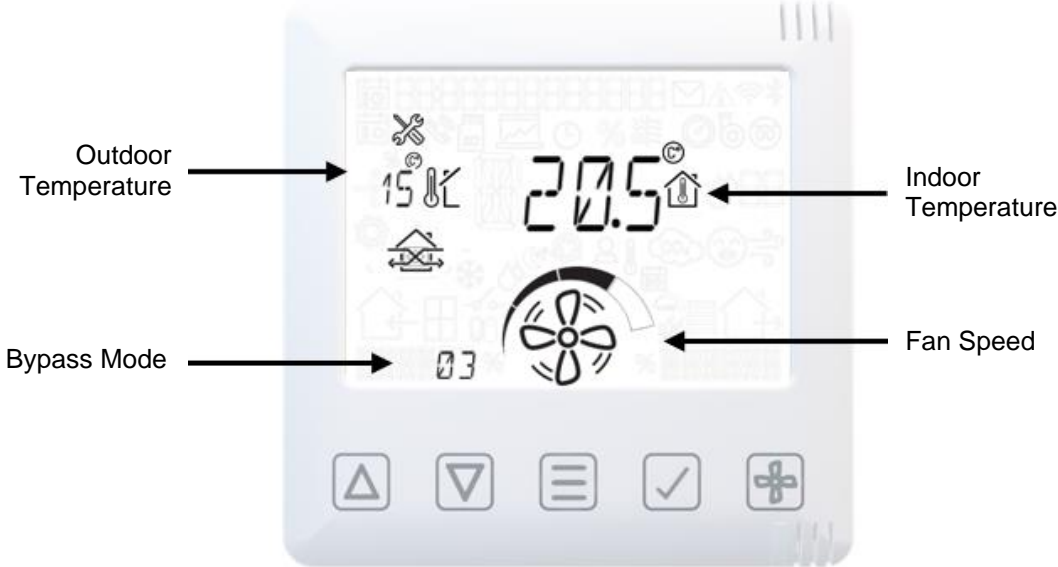

- Press 1 x for Bypass Mode
- Change Fan Speed - Low, Normal, Boost, Purge

00 = Disabled (not recommended)
 01 = Normal Bypass
 02 = Evening Fresh
 03 = Night Time Fresh
 See Annex F for details



- Press 2 x for Indoor Temperature
- Press 3 x for Outdoor Temperature
- Press 4 x for return to main menu
- Change field up/down

Engineer menu – Humidity

This is only visible when the humidity sensor is installed.



Enter/Confirm Selection

Change Relative Humidity between 50-90%

70% Default

Rapid rise can be Enabled/Disabled via the App. Along with Ambient response/overrun times.

This is only visible when the CO2 sensor is installed.



Enter/Confirm Selection

Change Fan Speed - low, normal, boost, purge



Change CO2 PPM Threshold

1000-2000 Default

Engineer menu – Date / Time



- Enter/Confirm Selection

- Change entry within below field.

- YY = Year
MM = Month
DD = Day
HH = Hour
MM = Minutes

Engineer menu – PIN Change

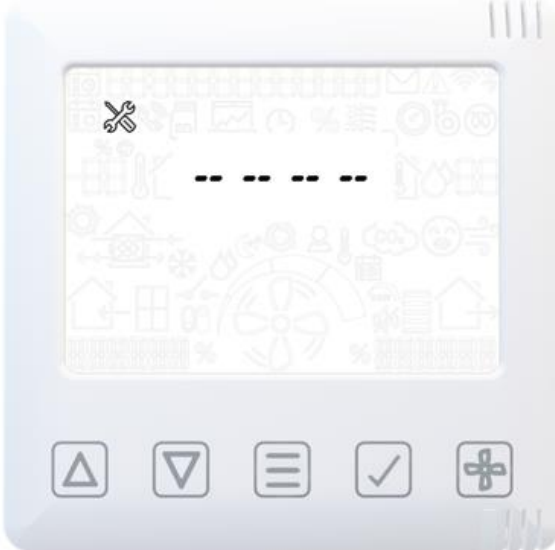

- Enter/Confirm Selection

- Change Pin Number 1-9

-

Engineer menu – Default settings

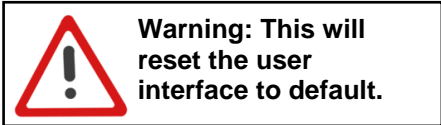

Push and hold the menu button for 15 seconds to reset to default including commission speeds.

LED will illuminate Red.

Engineer menu - HMI Hard Reset



Push and hold the menu button for 15 seconds.

LED will illuminate Red.

Press TICK to confirm HMI reset.

OR

Mobile App

The App allows the user easy access to commissioning, configuration, direct monitoring and control of the MVHR unit, using a smart phone or tablet with the **Vent-Axia Connect App**, available from the iTunes Store or on Google Play.



Maintenance



DISCONNECT THE APPLIANCE FROM ITS POWER SOURCE DURING SERVICE, MAINTENANCE OR WHEN REPLACING PARTS.

Caring for your Unit

Heat recovery units, by their very nature, require regular maintenance. The Sentinel Apex has been designed to facilitate access to enable maintenance to be carried out easily.

In addition to the maintenance tasks outlined below, periodic sterilisation of the unit in line with current medical advice on legionella risks is required. This is contained in a separate leaflet available from Vent-Axia.

6-Monthly Maintenance

The following 6-monthly maintenance is recommended:

Table 2: 6-Monthly Maintenance

Item	Action
General	Inspect the unit internally for build-up of dust, dirt and condensation. Clean as required.
Filters	A filter change alarm is triggered by final pressure drop. This could be less than 6 months depending on environmental conditions. Replace the filters if necessary. Note the filters are NOT washable. When the filter has been replaced, reset filter status by following the instructions on the Commissioning Interface Filter screen.

12-Monthly Maintenance

The following 12-monthly maintenance is recommended:

Table 3: 12 Monthly Maintenance

Item	Action
Heat Exchanger Cell	Inspect the cell for build-up of dust and dirt. Blow with an airline to clean it. Removal of the cell is not required for general cleaning.
Motors	Inspect the motors for build-up of dust and dirt on the impeller blades, which could cause imbalance and increased noise levels. Vacuum or wipe clean if necessary.
Condensate Tray	Wipe any wet surfaces with a dilute cleaning solution, such as Milton.
Condensate Drain	Check the condensate drain tube is secure and clear. Clean if necessary.
Filters	A filter change alarm is triggered by final pressure drop. Replace the filters if necessary. Note the filters are NOT washable. When the filter has been replaced, reset filter status by following the instructions on the Commissioning Interface Filter screen.

5-Yearly Maintenance

The following 5-yearly maintenance is recommended:

Table 4: 5-Yearly Maintenance

Item	Action
Battery	Replace the battery on the Main Controller PCB (type CR2032). Ensure positive (+) side is uppermost (i.e. visible) when replaced. Adjust the clock to agree with the local time. (See pages 23 and 40)

Removal/Replacement of Parts



WARNING

THIS EQUIPMENT PRESENTS ELECTRICAL, MECHANICAL AND NOISE HAZARDS. FAILURE TO USE SAFE WORKING PRACTICES AND OBSERVE THE RELEVANT REGULATIONS MAY RESULT IN DEATH OR SERIOUS INJURY. REMOVAL AND REPLACEMENT OF PARTS SHOULD ONLY BE PERFORMED BY QUALIFIED AND VENT-AXIA APPROVED SERVICE ENGINEERS. DISCONNECT THE APPLIANCE FROM ITS POWER SOURCE DURING SERVICE, MAINTENANCE OR WHEN REPLACING PARTS

Panel Removal/Replacement

Control Box Panel

Access to the control box is via a single removable panel.

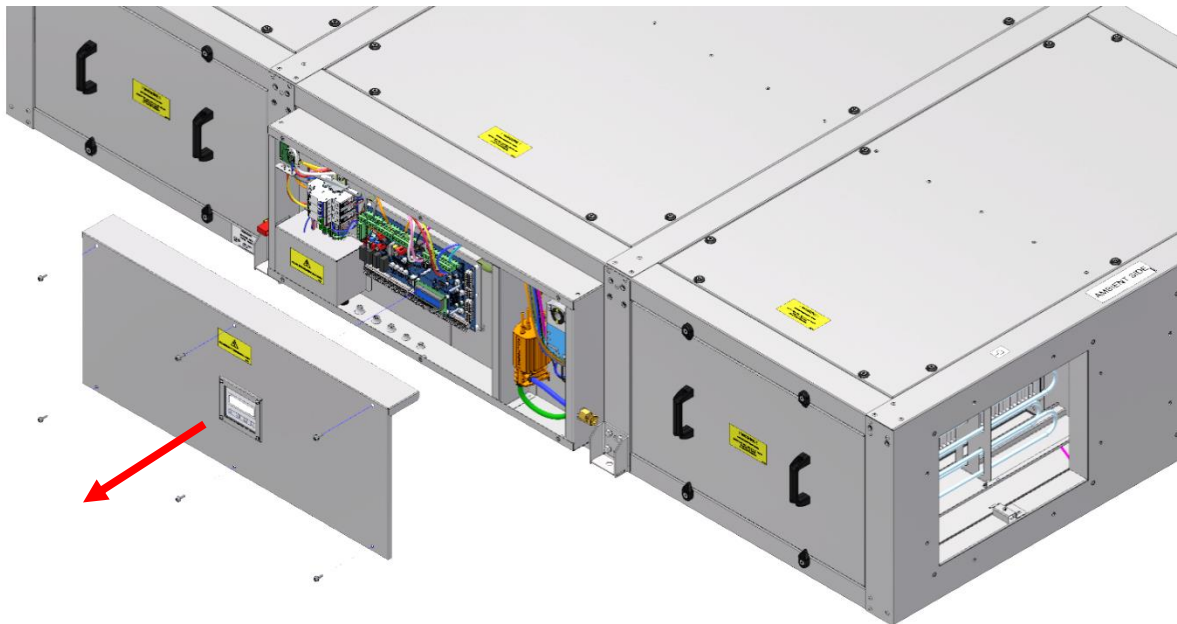

Removal:

1. Turn off and isolate the unit.
2. Use an appropriate tool to begin loosening the panel fixings by hand. Remove and retain 6 No. fixings and pull the panel away from the control box.

Replacement:

1. Position the cover onto the control box oriented with the long flange overlapping the top of the control box.
2. Replace the retained fixings and tighten by hand.

Side Access panels

Side access is from the control box side of the unit via 2 panels designed to be removed separately.

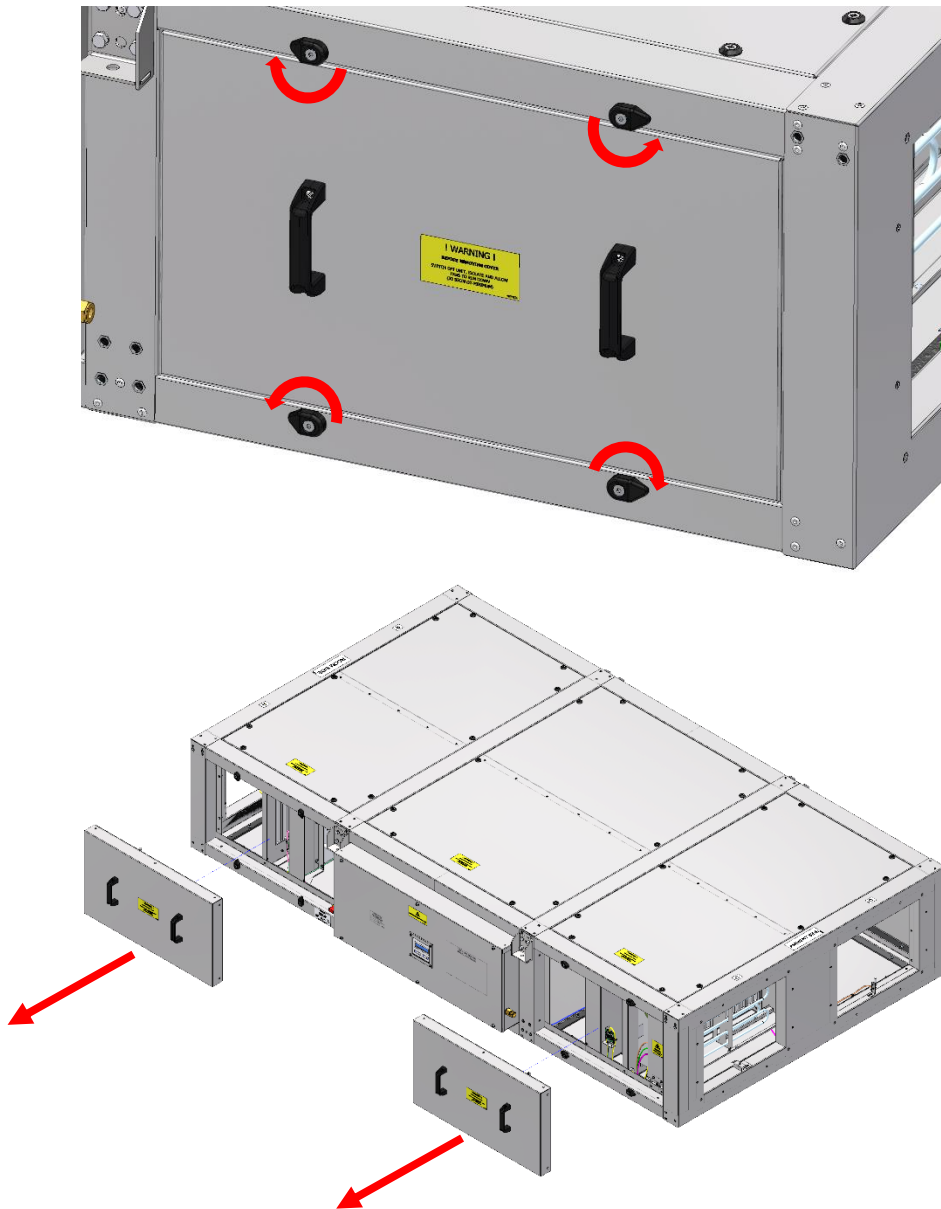

Removal:

1. Turn off and isolate the unit, allow at least 30 seconds for fans to run down.
2. Using an appropriately sized Allen key, loosen the turnbuckle fixing sufficiently to allow the turnbuckle to be rotated.
3. Using the two handles, pull the panel away from the frame.

Replacement:

1. Position the panel into the frame, ensure correct alignment of the filter bracket (inside face of the panel) with the filter edge.
2. Rotate the turnbuckles to secure the panels and firmly tighten the screws with a suitable Allen key to ensure the turnbuckles cannot be rotated by hand.

Notes:

The opposite side panels can be removed by unscrewing the fixings using, however removal is not required for routine maintenance.

Bottom Panels



WARNING

THIS EQUIPMENT PRESENTS A MANUAL HANDLING HAZARD. APPROPRIATE PRECAUTIONS SHOULD BE TAKEN WHEN REMOVING AND LOWER PANELS FROM THE UNIT.

Bottom access is via 3 panels designed to be removed separately.

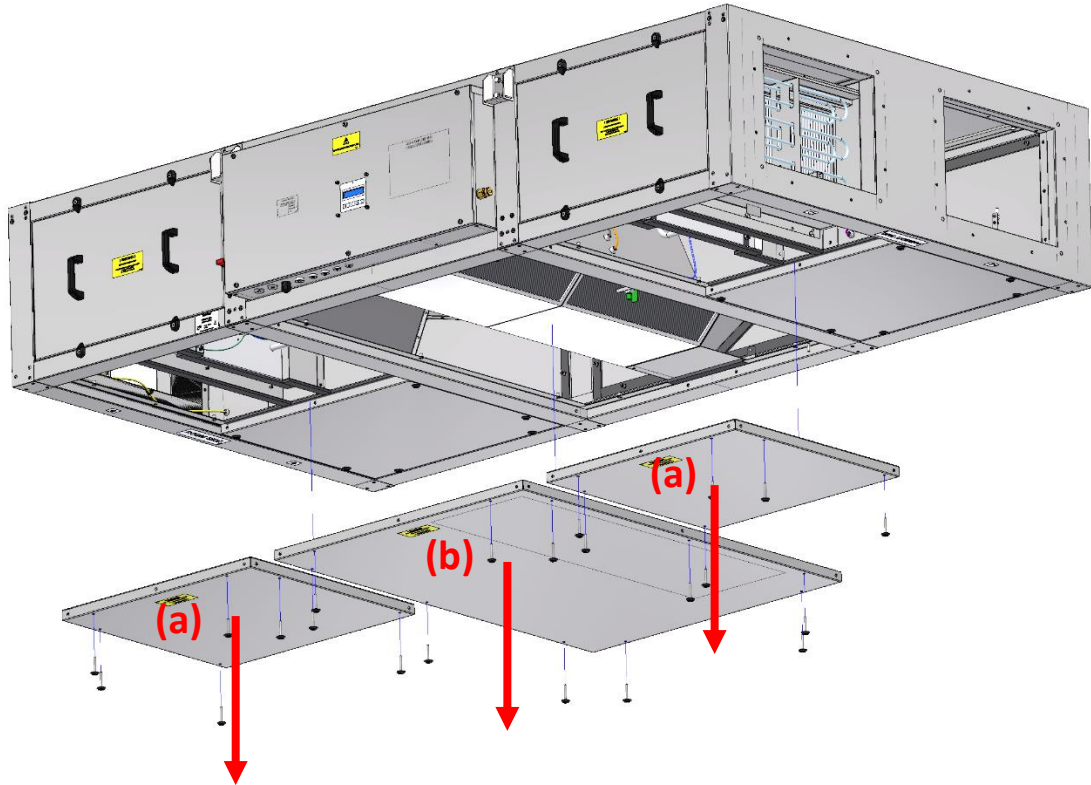

BOTTOM PANEL WEIGHTS (Kg)				
IDENTIFICATION	HR06X	HR10X	HR15X	HR21X
Outer Panel (a)	7.7	8.5	8.5	11.25
Centre Panel (b)	20.0	24.9	24.9	31.5

Removal:

1. Turn off and isolate the unit, allow at least 30 seconds for fans to run down.
2. Use an appropriate tool to begin loosening the panel fixings by hand. The panel may start to drop out of the chassis, support the panel to prevent it falling out. Attach a suction lifter to the panel prior to complete removal of the fixings.
3. Once all fixings are removed, lower the panel away from the unit and set it aside. Use the attached suction lifter to assist with manoeuvring.

Replacement:

1. Lift the panel into the recess in the chassis and support it in position while the retained fixings are inserted.
2. Tighten the fixings by hand to secure the panel and seal the air path.

Notes:

- The far side bottom split panels can be removed in the same way, but removal is not required for routine maintenance.
- The centre panel has an integrate condensate tray which may contain water.
- When refitting, the centre panel must be correctly oriented to locate with the guide pins on the chassis.

Top Panels

Top access is via 3 panels designed to be removed separately. Access via the top panels is intended only for installations where bottom and side access is not possible.

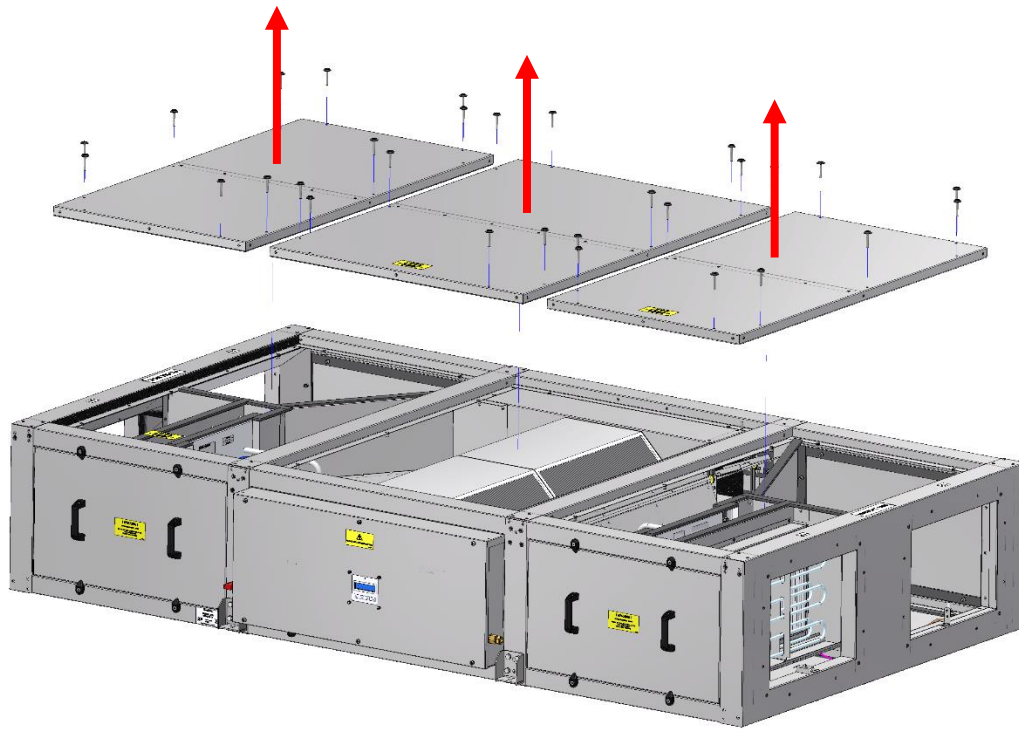

Removal:

1. Turn off and isolate the unit, allow at least 30 seconds for fans to run down.
2. Use an appropriate tool to begin loosening the panel fixings by hand. Remove and retain the 10 No. fixings per panel.
3. Secure a suction lifter to the panel. Lift the panel from the recess in the chassis and place out of the way.

Replacement:

1. Lower the panel into the recess in the chassis with the help of a suction lifter.
2. Replace the retained fixings and tighten by hand, to secure the panel and seal the air path.

Note:

On HR10X and HR15X models, top centre panel must be correctly oriented to locate with the guide pins on the chassis.

Filter Removal & Replacement (Side Access)

Filters are fitted to both supply and extract air inlets to prevent dust being drawn into the unit. The unit uses pressure measurements to detect when a filter requires replacement.

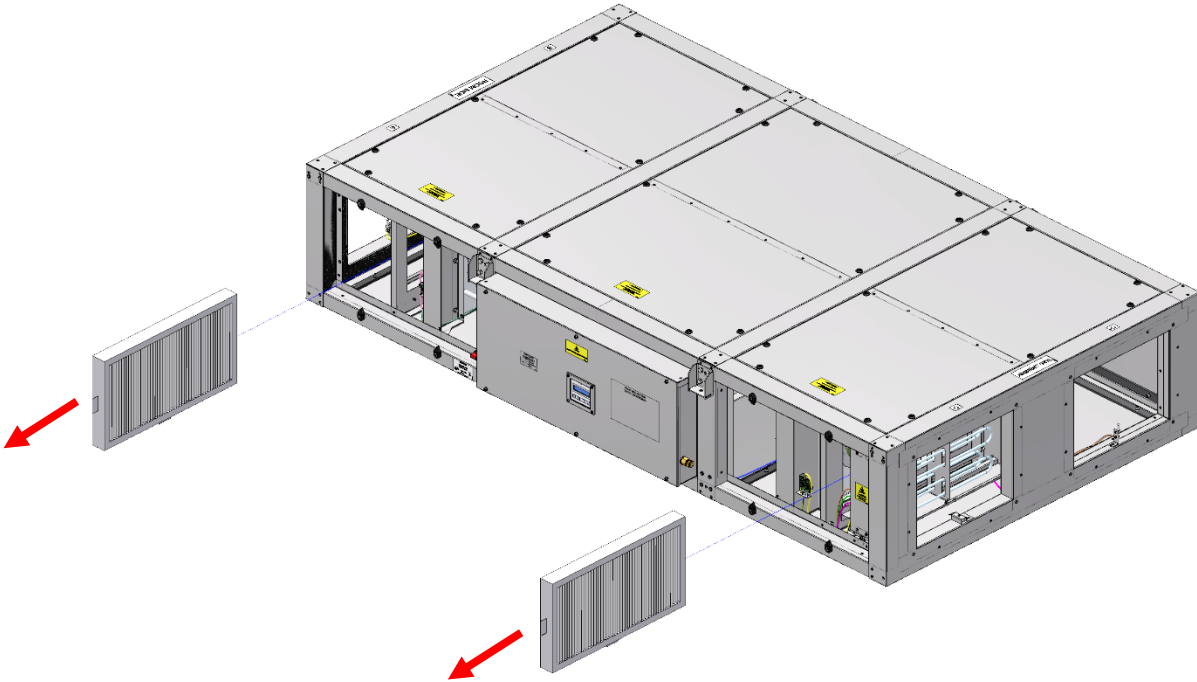

Removal:

1. Turn off and isolate the unit, allow at least 30 seconds for fans to run down.
2. Remove the side access covers (see the *Panel Removal/Replacement* section of this Manual).
3. Loosen the 4 No. wing bolts securing the top and bottom filter brackets to release the clamping pressure on the filter. The fixings do not need to be fully removed.
4. Withdraw the filter by pulling firmly on the pull tab and sliding it out of the unit.

Replacement:

1. Remove the new filter from its packaging, confirm filter grade, and identify the direction of flow through the filter as stated on the label. (See *Appendix B: Options and Accessories* of this Manual for filter options and part numbers)
2. Slide the new (clean) filter into the unit. Ensure one pull tab points down and the other towards the access panel.
3. Tighten the wing bolts to secure the filter brackets firmly against the filter.
4. Replace the side access cover (see *Panel Removal/Replacement* section of this manual).
5. Reset filter service indicator on HMI (see *On-board User Menu* section)

Filter Removal & Replacement (Bottom Access)

Filters are fitted to both supply and extract air inlets to prevent dust being drawn into the unit. The unit uses pressure measurements to detect when a filter requires replacement.

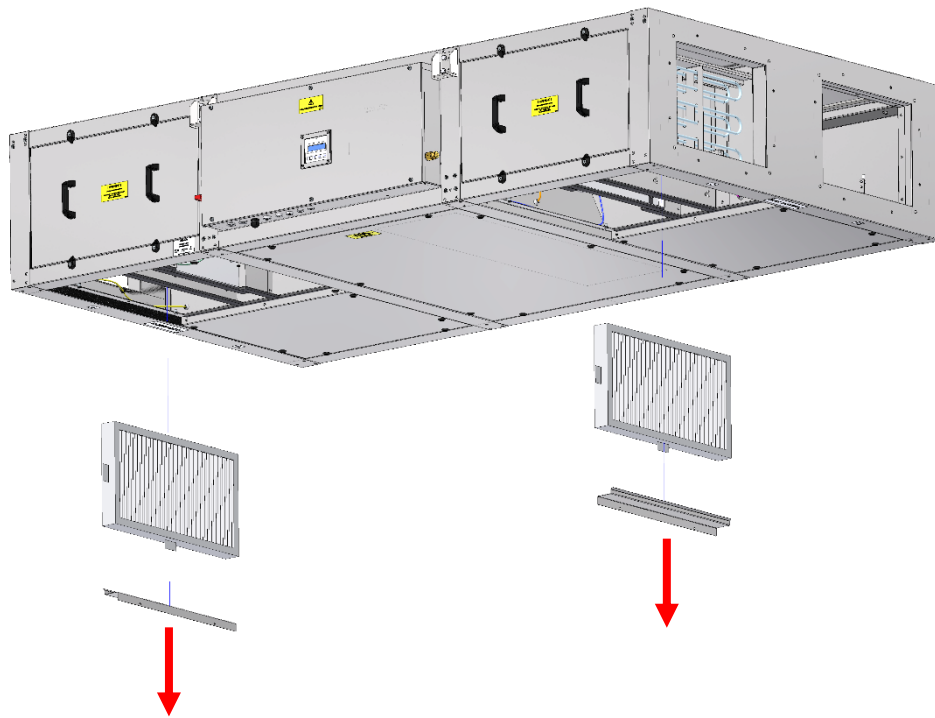

Removal:

1. Turn off and isolate the unit, allow at least 30 seconds for fans to run down.
2. Remove the bottom access split panel on the side closest to the control box (see *Panel Removal/Replacement* section of this Manual).
3. Loosen the wing bolts securing the top and bottom filter brackets to release the clamping pressure on the filter.
4. Remove the bottom filter bracket to expose the bottom edge of the filter.
5. Withdraw the filter by pulling firmly on the pull tab and sliding it down out of the unit.

Replacement:

1. Remove the new filter from its packaging, confirm filter grade, and identify the direction of flow through the filter as stated on the label. (See *Appendix B: Options and Accessories* of this manual for filter options and part numbers)
2. Slide the new (clean) filter into the unit. Ensure one pull tab points down and the other towards the access panel.
3. Refit bottom filter bracket and fixings.
4. Tighten the wing bolts to secure the filter brackets firmly against the filter.
5. Replace access cover (see *Panel Removal/Replacement* Section of this manual).
6. Reset filter service indicator on HMI (see *On-board User Menu* Section of this manual)

Motor Removal & Replacement (Roof-Mounted)

Two motors are used to draw in supply air and extract air into the unit. Each motor is positioned at the inlet of each airpath. Each motor can be accessed by removing a single top cover. Removal of the motors is not part of routine maintenance and is only required in the unlikely event that a motor failure occurs.

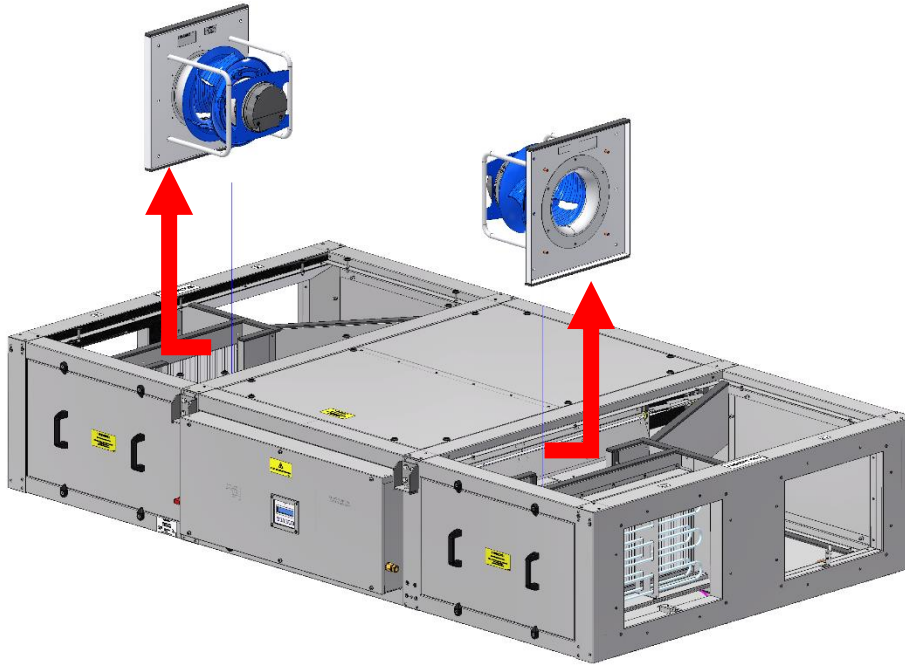

Removal:

1. Turn off and isolate the unit, allow at least 30 seconds for fans to run down.
2. Remove top outer panels (see *Panel Removal/Replacement* section of this Manual).
3. Disconnect the motor cables and pressure pipe from the motor tapping.
4. Remove and retain the motor fixings securing the motor to the chassis. Note that HR15X and HR21X fans include a motor plate and must be removed with the fan.
5. Pull the motor away from the mounting studs, then withdraw the motors through the top of the unit.

Replacement:

1. Lower each new motor into the unit. For HR15X and HR21X units, rest the motor plate onto the mounting studs.
2. Secure the motor with the retained fixings.
3. Reconnect the motor cables and pressure pipe to the motor tapping. Ensure cables and pipes do not foul the impeller.
4. Switch the unit on and check direction of rotation is correct.
5. Replace the top outer panels (see *Panel Removal/Replacement* section of this Manual).

Note:

Pictured is an HR15X unit, motor removal and fixing type for other units may vary.

Motor Removal & Replacement (Ceiling-Mounted)

Two motors are used to draw in supply air and extract air into the unit. Each motor is positioned at the inlet of each airpath. Each motor can be accessed by removing a single bottom cover. Removal of the motors is not part of routine maintenance and is only required when a failure occurs.

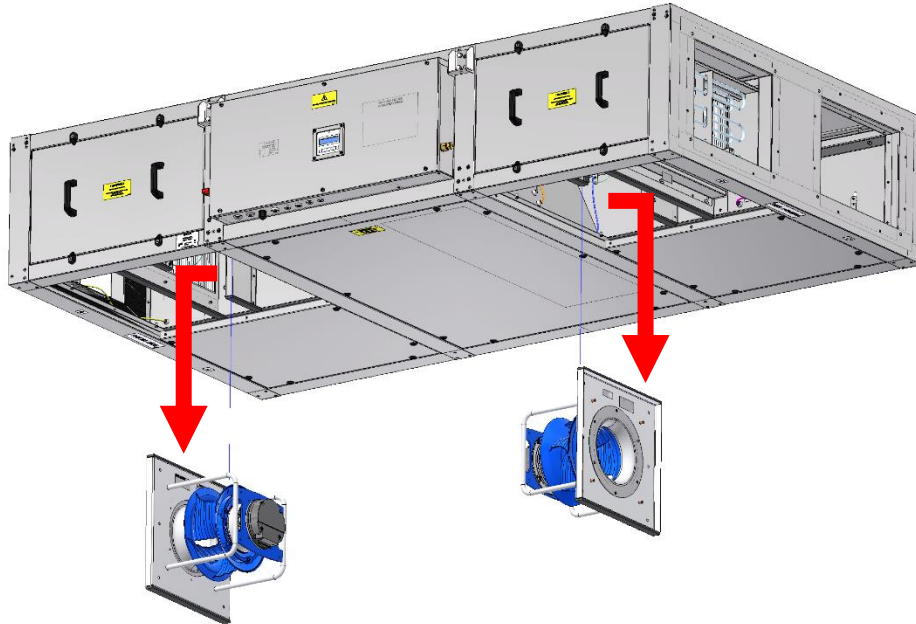

Removal:

1. Turn off and isolate the unit, allow at least 30 seconds for fans to run down.
2. Remove the bottom access split panel on the side closest to the control box (see *Panel Removal/Replacement* section of this Manual).
3. Disconnect the motor cables and pressure pipe from the motor tapping.
4. Remove and retain the motor fixings securing the motor plate to the chassis.
5. Pull the motor away from the mounting studs, supporting its weight, then withdraw the motors through the bottom of the unit.

Replacement:

1. Raise each new motor into the unit and fit onto the mounting studs.
2. Secure with the retained fixings.
3. Reconnect the motor cables and pressure pipe to the motor tapping. Ensure cables and pipes do not foul the impeller.
4. Switch the unit on and check direction of rotation is correct.
5. Replace the bottom access panels (see *Panel Removal/Replacement* section of this Manual).

Note:

Pictured is an HR15X unit, motor removal and fixing type for other units may vary.

Heat Exchanger Removal & Replacement (Roof-Mounted)

Two heat exchangers span the centre of the unit with gaskets on the end faces to seal the air path. The heat exchangers are secured with clamping strips on either side. Each one can be accessed and removed through the top or bottom panels. Removal of the cells is not part of routine maintenance and is only required in the unlikely event that damage has occurred to the cell.

Removal:

1. Turn off and isolate the unit, allow at least 30 seconds for fans to run down.
2. Remove top centre panel (see *Panel Removal/Replacement* section of this Manual)
3. Remove and retain 6 No. fixings on each clamp strip, then lift both clamp strips out of the unit.

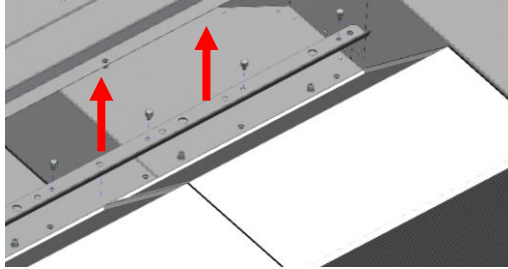

4. Secure a suction lifter to the heat exchanger furthest from the control box and lift (a).
5. Slide the second heat exchanger away from the control box so that the top face is not obstructed under the frame, then repeat stage 4 to remove it (b).

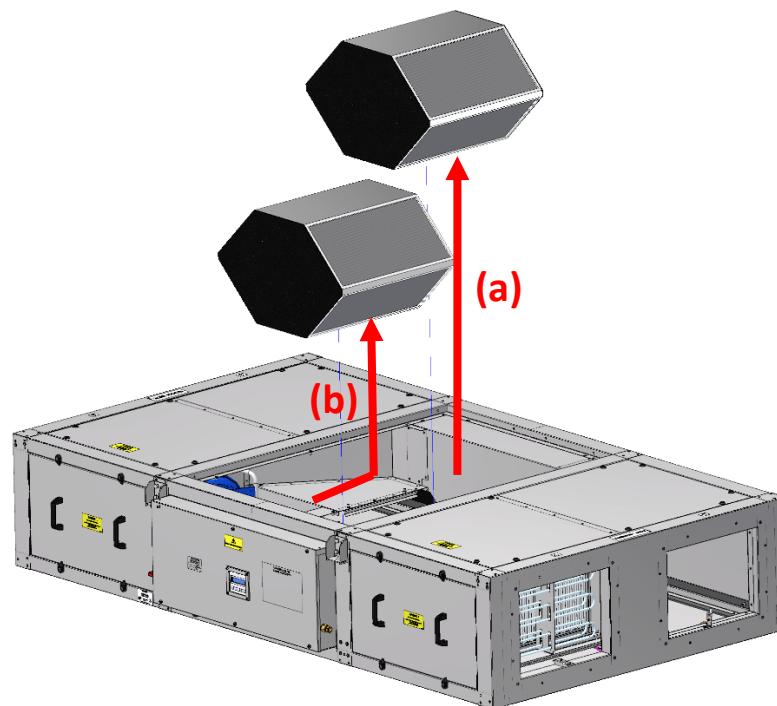

Replacement:

1. Apply quick drying silicone lubricant spray liberally to the foam gaskets on the heat exchanger end faces, and foams within the unit.
2. Lower the first heat exchanger into the unit and slide towards the control box ensuring it tucks under the foam blocks on the top and bottom frame.
3. Lower the second heat exchanger into position, applying uniform pressure to the top face as required.
4. Refit the clamp strips and replace the top panel (see *Panel Removal/Replacement* section of this Manual).

Heat Exchanger Removal & Replacement (Ceiling-Mounted)

Two heat exchangers span the centre of the unit with gaskets on the end faces to seal the air path. The heat exchangers are secured with clamping strips on either side. Each one can be accessed and removed through the top or bottom panels. Removal of the cells is not part of routine maintenance and is only required in the unlikely event that damage has occurred to the cell .

Removal:

1. Turn off and isolate the unit, allow at least 30 seconds for fans to run down.
2. Remove bottom centre panel (see Panel Removal/Replacement on page 45).
3. Locate the condensate sensor mounted to one of the bottom frame members. Loosen, but do not remove, the 2No wing bolts clamping it in position (a). Pivot the condensate sensor out of the way to prevent damaging it when the heat exchangers are removed (b).

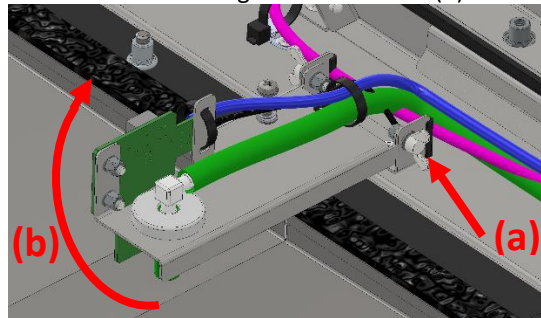

4. Ensuring the heat exchanger furthest from the control box is suitably supported, remove the clamp strips which secure it in place.

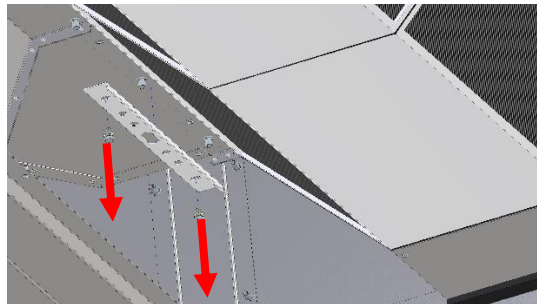

5. Lower the heat exchanger from the unit. Use a suction lifter to the bottom face to apply downward force if required.

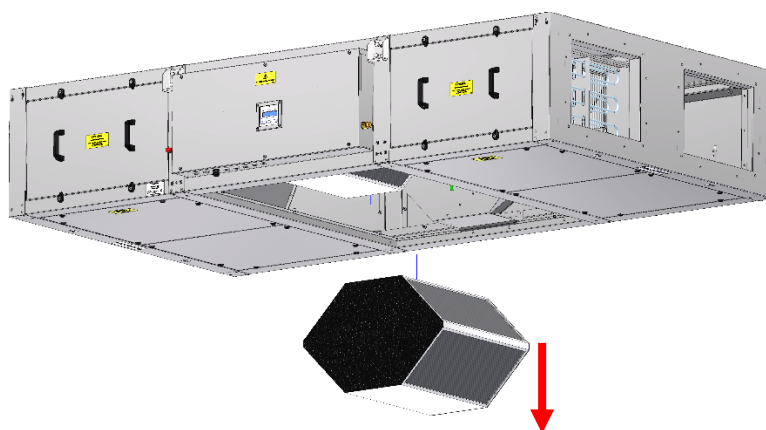

6. Ensuring the heat exchanger closest to the control box is suitably supported, remove the clamp strips which secure it in place.
7. Slide the heat exchanger away from the control box so that it is not obstructed by the bottom frame, then repeat stage 5.

Replacement:

1. Apply silicone lubricant spray liberally to the foam gaskets on the heat exchanger end faces, and foams within the unit.
2. Raise the first heat exchanger into the unit and slide towards the control box ensuring it tucks under the foam blocks on the top and bottom frame.
3. Secure the heat exchanger with the clamping strips to prevent it dropping out.
4. Raise the second heat exchanger into position, applying uniform pressure to the bottom face as required.
5. Refit the remaining clamp strips.
6. Pivot the condensate sensor back down (a), ensuring the height adjustment screw (b) is sitting firmly on the frame. **DO NOT** adjust the screw. Tighten the wing bolts (c) on both sides of the bracket to clamp the sensor position.

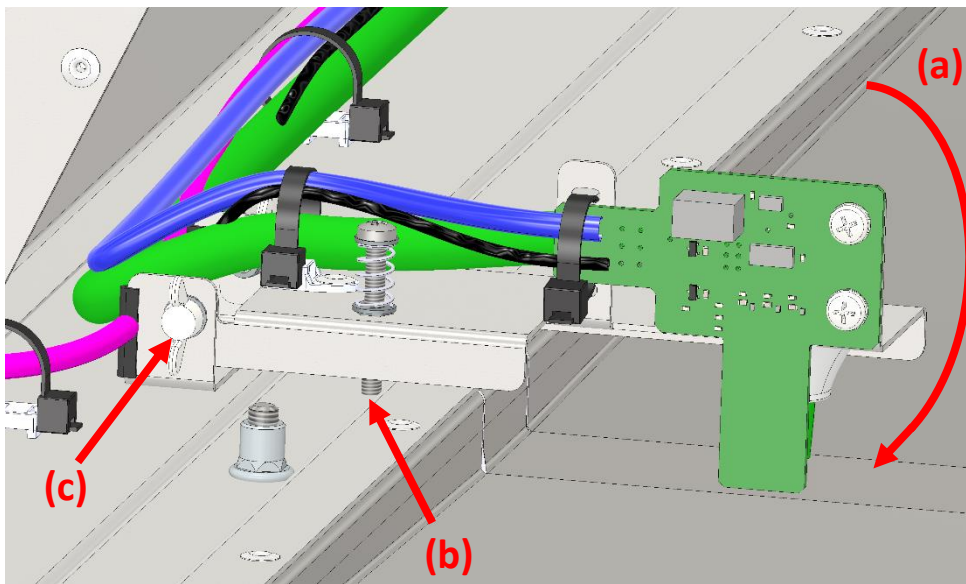

7. Replace the bottom centre panel (see *Panel Removal/Replacement* section of this Manual).

Condensate Sensor Removal & Replacement (Roof-Mounted)

A condensate sensor is used to trigger the condensate pump when there is a build-up of condensation within the unit. It is located underneath the heat exchanger which requires removal to access when roof-mounted.

Removal:

1. Turn off and isolate the unit, allow at least 30 seconds for fans to run down.
2. Remove the top centre panel (see *Panel Removal/Replacement* section of this Manual).
3. Remove the heat exchangers (see *Heat Exchanger Removal & Replacement (Roof-Mounted)* section of this Manual).
4. Remove the control box cover (see *Panel Removal/Replacement* section of this manual).
5. Disconnect the two sensor cables:
 - 5.1. Locate the DIN connector near the condensate pump, within the control box. Pull the two connectors apart to disconnect the signal cable to the pump.
 - 5.2. Identify the sensor supervision terminals on the main control board. Using a terminal driver, loosen the screws and remove the cable from the connector.
6. Push the grommets out of the control box and feed the cables through into the air path. Follow the route of the sensor cables and cut cable ties if required to ensure the cables are fully released.
7. Remove and retain 2No. fixings holding the sensor to the bracket, then lift the sensor out of the unit.

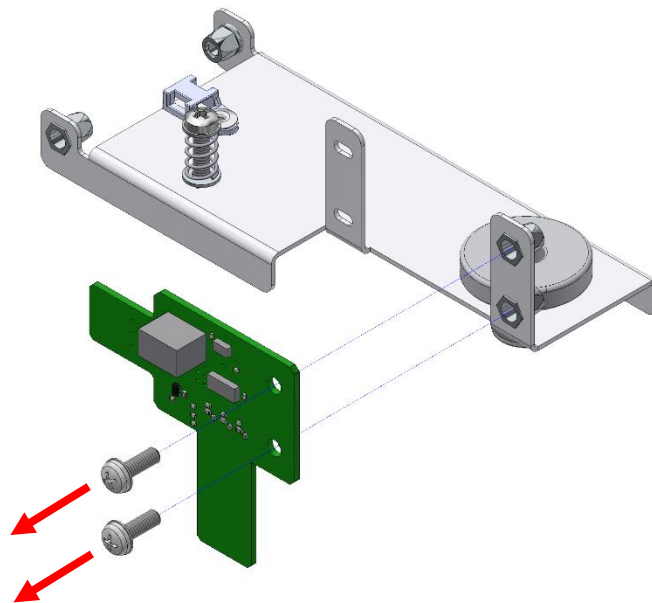

Replacement:

1. Screw the new sensor to the bracket with the retained fixings.
2. Route the sensor cables along the chassis and into the control box. Ensure the grommets are pushed into the holes to seal the control box and replace all zip ties.
3. Re-connect the sensor cables to the pump and control board.
4. Ensure that the sensor bracket adjustment screw is still sitting against the chassis. Replace the heat exchangers (see *Heat Exchanger Removal & Replacement (Roof-Mounted)* on page 51).
5. Replace the top panel (see *Panel Removal/Replacement* on page 46).
6. Replace the control box cover (see *Panel Removal/Replacement* on page 43).

Condensate Sensor Removal & Replacement (Ceiling-Mounted)

A condensate sensor is used to trigger the condensate pump when there is a build-up of condensation within the unit. It is located underneath the heat exchanger and requires removal of the bottom centre panel when ceiling mounted.

Removal:

1. Turn off and isolate the unit, allow at least 30 seconds for fans to run down.
2. Remove the bottom centre panel (see *Panel Removal/Replacement* section of this Manual).
3. Remove the control box cover (see *Panel Removal/Replacement* section of this Manual).
4. Disconnect the two sensor cables:
 - 4.1. Locate the DIN connector near the condensate pump, within the control box. Pull the two connectors apart to disconnect the signal cable to the pump.
 - 4.2. Identify the sensor supervision terminals on the main control board. Using a terminal driver, loosen the screws and remove the cable from the connector.
5. Push the grommets out of the control box and feed the cables through into the air path. Follow the route of the sensor cables and cut cable ties if required to ensure the cables are fully released.
6. Remove and retain 2No. fixings holding the sensor to the bracket, then lift the sensor out of the unit.

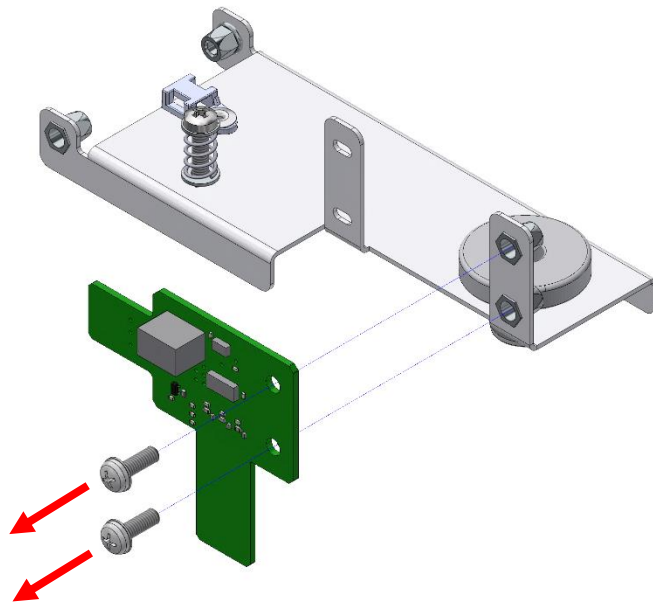

Replacement:

1. Screw the new sensor to the bracket with the retained fixings.
2. Route the sensor cables along the chassis and into the control box. Ensure the grommets are pushed into the holes to seal the control box and replace all zip ties.
3. Re-connect the sensor cables to the pump and control board.
4. Ensure that the sensor bracket adjustment screw is still sitting against the chassis.
5. Replace the top panel (see *Panel Removal/Replacement* section of this Manual).
6. Replace the control box cover (see *Panel Removal/Replacement* section of this Manual).

Condensate Pump Removal & Replacement

The condensate pump is located in the control box. When triggered by the condensate sensor, the pump will draw water from the condensate tray and discharge it out of the unit. The method for removal and replacement is the same for ceiling and roof mounted installations.

Removal:

1. Turn off and isolate the unit.
2. Remove the control box cover (see *Panel Removal/Replacement* section of this Manual).
3. Squeeze the pipe clamps to open them up, then slide them out of the way. Pull the hose off the pump inlet and outlets.

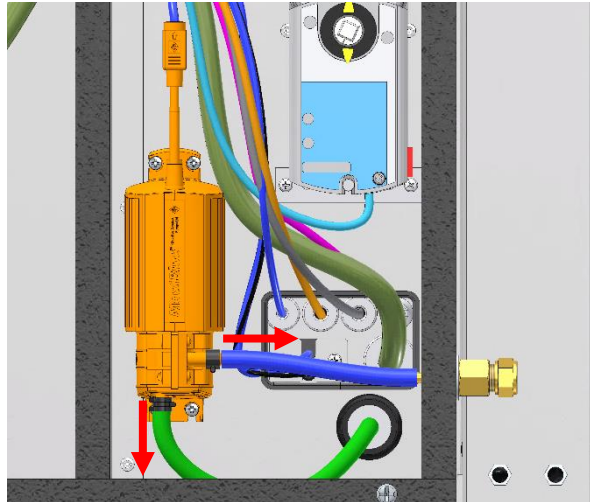

4. Disconnect the power cable from the main board and signal cable from the sensor.
5. Remove and retain 4No. pump fixings screws and withdraw the pump.

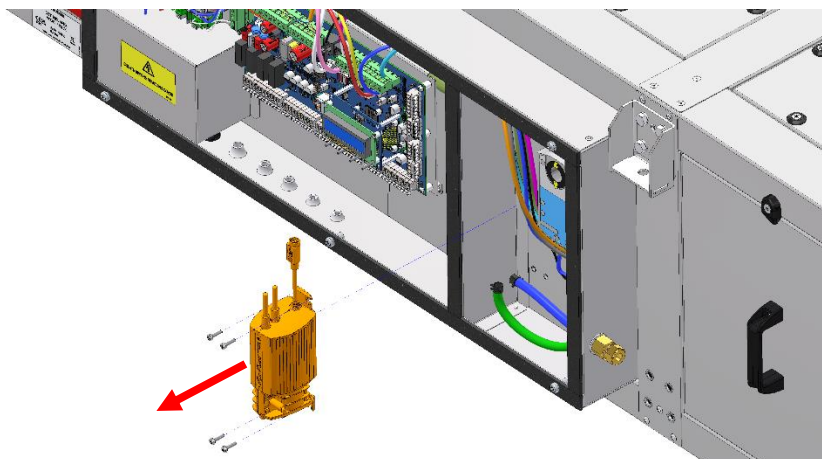

Replacement:

1. Place the condensate pump into position and secure with retained screws. Note that it can only be fitted in one orientation.
2. Reconnect the power and signal cables. Note: pump relay cable is not used.
3. Reconnect pipes to the pump inlet and outlet, then slide the clamps on. Check the connections of inlet and outlet match the flow direction arrows on the pump body.
4. Replace the control box cover (see *Panel Removal/Replacement* section of this Manual).

Note:

Pump mounting orientation varies across unit. Method of removal is the same.

Pre-Heater Removal & Replacement

A pre-heater is used to raise the temperature of the supply air when required, dependant on ambient air temperature. The pre-heater is located at the ambient intake and is accessed via the side panel. The pre-heater assembly houses the heating elements, overheat thermostats, and the heater control PCB.

Removal:

1. Turn off and isolate the unit, allow at least 30 seconds for fans to run down.
2. Remove the side access panel at the ambient end (see *Panel Removal/Replacement* section of this manual)
3. Remove and retain the screws on the face of the heater cover.
4. Pull the heater cover away from the heater cartridge. Note that on HR06X units the PCB is mounted to the cover. Disconnect the wires between the PCB and heater before full removal.

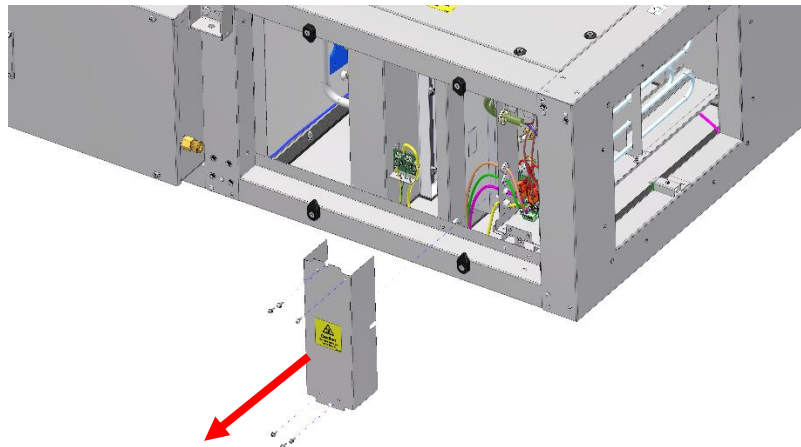

5. Locate the locking bolts on the rear edge of the Frost Heater Rails which the Heater Assembly sits in. One on the Top Rail and one on the Bottom Rail. Remove using a 7mm spanner or socket wrench and retain these fixings.

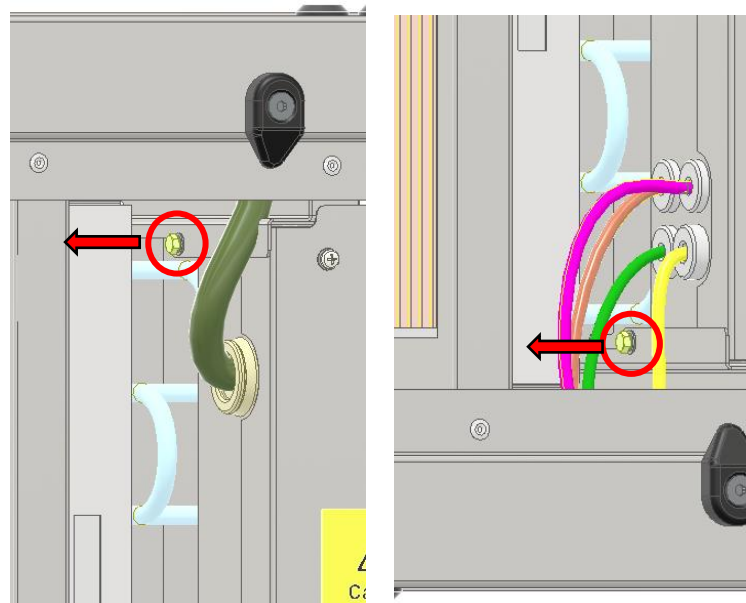

6. Remove all cables from the heater assembly to allow its removal:
 - 6.1. Remove power cable by pulling the terminals from the spades, unscrewing the earth terminal ring, then pushing the grommet from the hole in the enclosure.

Removal & Replacement of Parts

- 6.2. Disconnect thermistors from T1 and T4 on the heater PCB, then push the grommets out of the heater enclosure.
- 6.3. Disconnect the pressure sensor cable from I2C1 on the heater PCB, then push the grommet out of the heater enclosure.
- 6.4. Pull the 6-way screw terminal away from the connector on the heater PCB, loosen all terminals and remove the wires from the connector, then push the grommet out of the heater enclosure.
7. Pull the heater assembly to withdraw it from the unit.

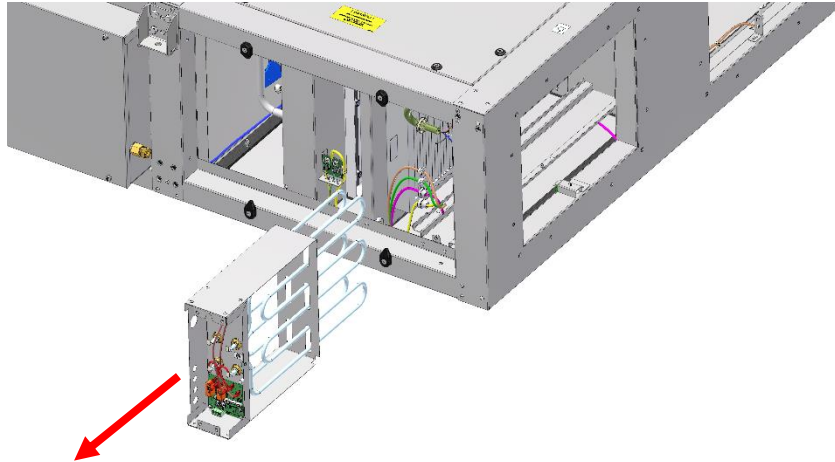

Replacement:

1. Slide the heater assembly into the carriage. Ensure it is oriented with the notch at the bottom to align with the nutsert within bottom tray.

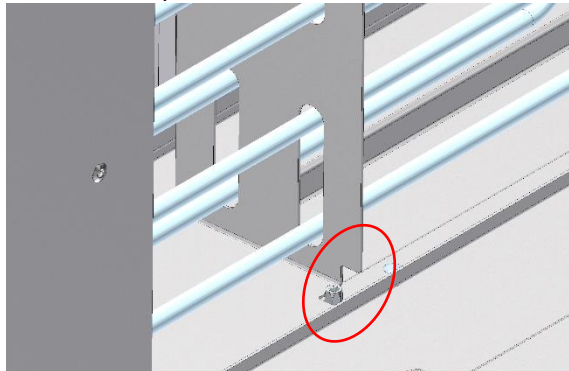

2. Refit all cable grommets into the enclosure and refit connectors.
 - 2.1. Refit the two thermistors to PCB connectors T1 and T4, and the pressure sensor to PCB connector I2C1.
 - 2.2. Refit the power cable grommet into the enclosure, then connect each terminal to the heaters and thermostats.
 - 2.3. Refit the 6-way cable into the heater enclosure, fit each wire into the screw terminal, and push the connector onto the board.

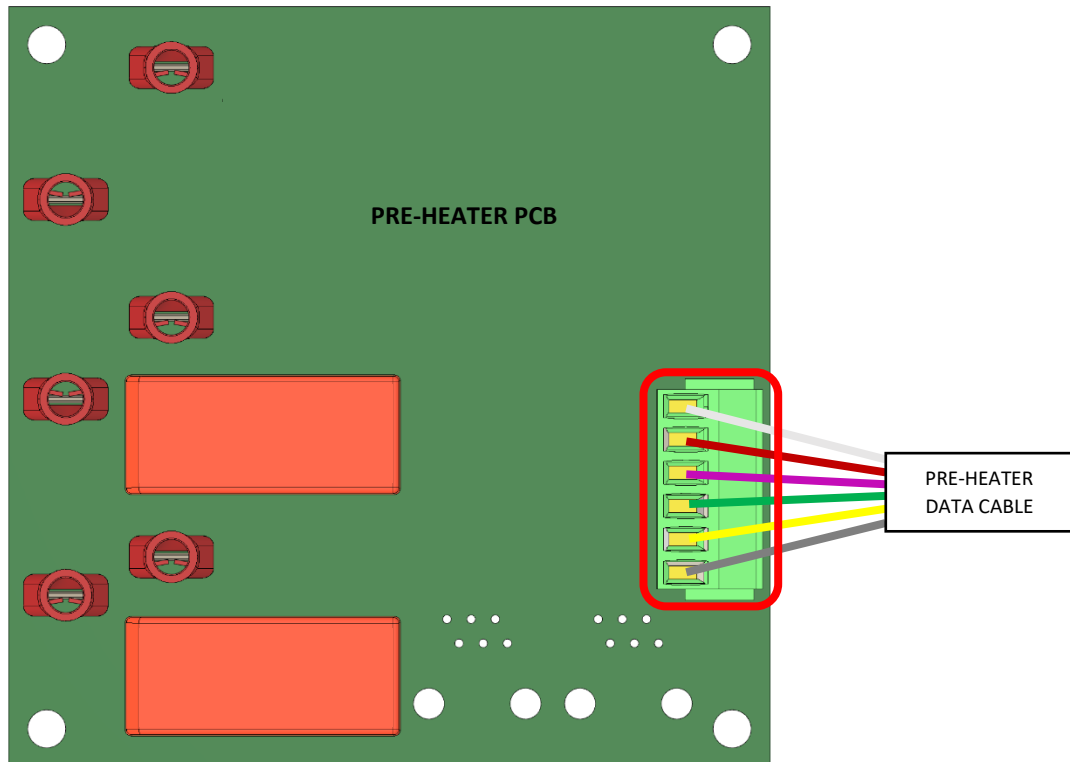

3. Replace the heater cover and secure it to the heater assembly with 4No fixings.
4. Push the heater assembly fully into the unit. Align the top and bottom slots with the holes in the chassis, then secure with 2No. retained fixings.

Actuator Removal & Replacement

Removal:

1. Turn off and isolate the unit.
2. Remove the control box cover (see *Panel Removal/Replacement* section of this Manual).
3. Disconnect the actuator plug from the Main Control PCB .
4. Press the actuator clutch (a) and manually move the damper fully to one end (b). This will unsecure the new actuator can be put on in the same position.

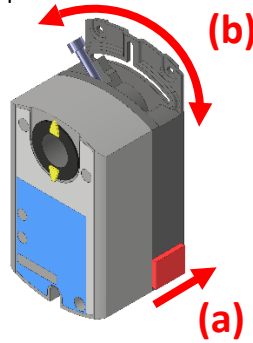

5. Loosen the shaft clamping screw.
6. Remove and retain the 2No. fixings which hold the actuator mounting strip to the control box.
7. The actuator can now be pulled out of the control box. Note that there is a small shaft adapter bush, care should be taken to ensure that it does not fall out or get lost.

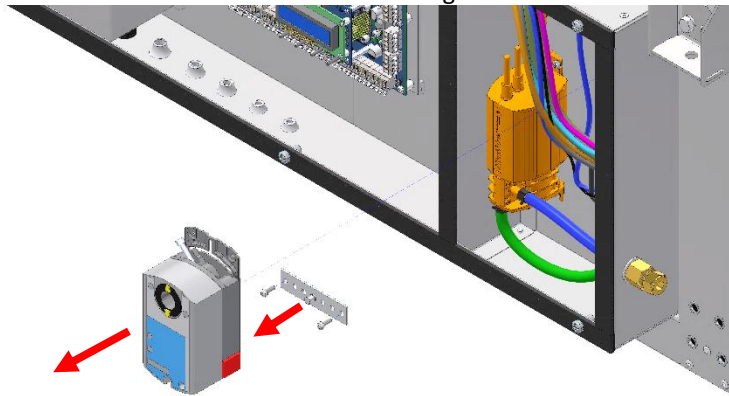

8. Using a terminal driver, remove and retain the green connector plug on the end of the motor cable.

Replacement:

1. Press the clutch and manually move the new actuator to the same position as the old, removed, actuator.
2. Push the actuator onto the shaft ensuring that the adapter bush remains in place.
3. Slide the actuator mounting strip into position such that the pin fits into the slot in the back of the actuator.
4. Secure the actuator to the control box with the retained fixings.
5. Tighten the shaft clamping screw.
6. Route the cable so the control board and fit the retained PCB connector. Plug the connector onto the PCB.

Note:

Actuator model and mounting orientation varies across unit. Method of removal is the same.

Actuator PSU Removal & Replacement (HR21X Model ONLY)

On HR21X models, there is an additional power supply to run the larger actuator. It is mounted within the control box.

Removal:

1. Turn off and isolate the unit.
2. Remove the control box cover (see *Panel Removal/Replacement* of this Manual).
3. Remove 2No. M3 screws to release the PSU.
4. Turn the PSU over to access the screw terminals on the back and remove the connections.

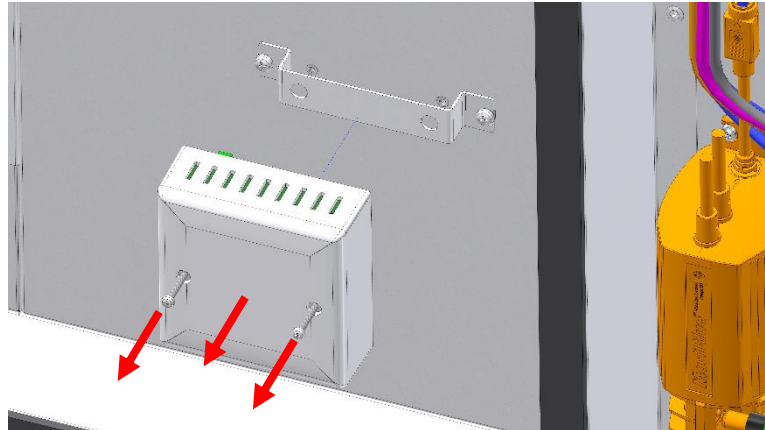

Replacement:

1. Refit the wires into the terminal block on the new PSU.
2. Align the PSU with the bracket in the control box and fit the retained fixings.
3. Replace the control box cover (see *Panel Removal/Replacement* of this Manual).

Main Control PCB Removal & Replacement

Removal:

1. Turn off and isolate the unit.
2. Remove the control box cover (see *Panel Removal/Replacement* of this Manual).
3. To transfer settings to the new board, ensure a micro SD card is fitted into the slot on the main control board and use the HMI to Save the settings. (see *On-board User Menu* section of this manual). **The unit will need to be Turned On to do this so follow safe practice by replacing the electrical covers for this stage.** Once complete Turn off and isolate the unit.
4. Remove all plugs and connectors from the main board.
5. Remove and retain 6No fixings securing the board to the control box.

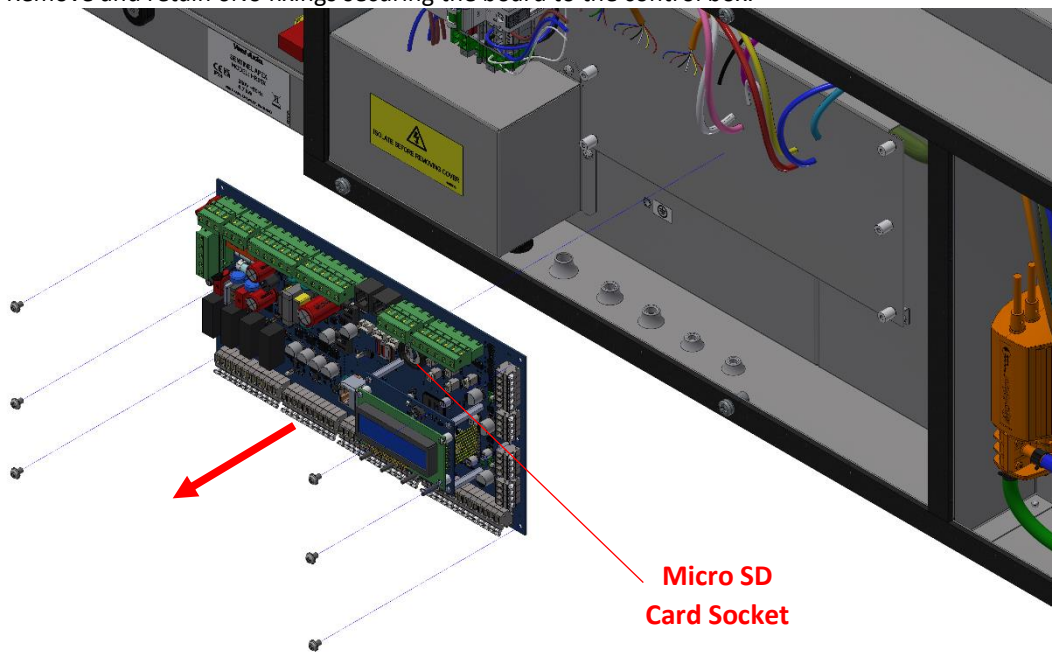

Replacement:

1. Secure the new board into position using the retained fixings.
2. If loading setting from the old board, push the SD card into the slot on the new board.
3. Power on the unit to check the new board functions correctly.
4. If an SD card was fitted, load settings from the SD card (see *On-board User Menu* section of this manual).
5. Replace the control box cover (see *Panel Removal/Replacement* section of this manual).

Pressure Sensor PCB Removal & Replacement

Each Apex unit is fitted with 3 pressure sensor PCB's. One is located within the control box, the other two are in each intake, in between the filter and fan plate. The pressure sensors in each intake are used for monitoring filter status and will trigger a filter change when required.

Removal:

1. Turn off and isolate the unit, allow at least 30 seconds for fans to run down.
2. For the single pressure sensor, remove the control box cover (see *Panel Removal/Replacement* section of this manual). For the dual pressure sensors, remove the required side access panel (see *Panel Removal/Replacement* section of this manual).
3. Locate the pressure sensor. Disconnect the pressure tubes and cables.
4. If access to the PCB fixings screws is restricted, remove 2No M4 fixings to release the PCB and bracket assembly first.
5. Remove and retain 3No. fixings securing the PCB to the bracket.

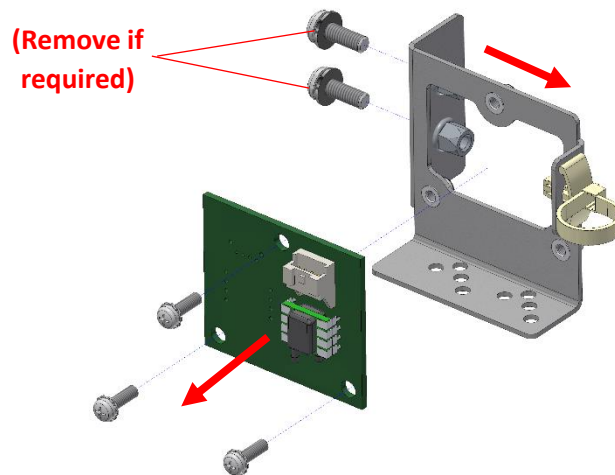

Replacement:

1. Secure the new PCB to the bracket using the retained fixings.
2. If required, refit the bracket and PCB assembly into the control box.
3. Reconnect the pressure tubes and cable as shown in the table below.
4. Replace whichever access cover was removed previously.

Table 5: Pressure Sensor Connections

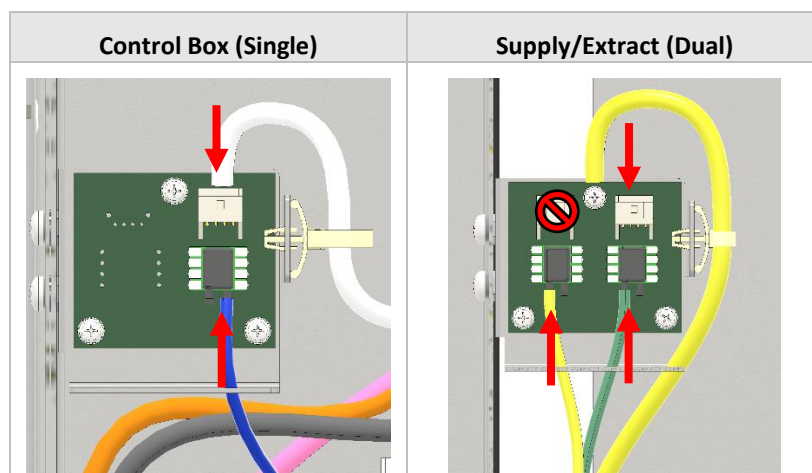

Heater Control PCB Removal & Replacement

Removal:

1. Turn off and isolate the unit, allow at least 30 seconds for fans to run down.

Remove the ambient end side access panel (see *Panel Removal/Replacement* section of this Manual) and heater assembly cover (see

Removal & Replacement of Parts

2. Pre-Heater Removal & Replacement section of this Manual, up to step 4).
3. Remove all connectors from the PCB. Remove and retain the fixing which secures the Triac to the sheet metal (a).
4. Remove and retain 4No. fixings holding the PCB to the standoffs in the heater enclosure (b). Note on HR06X models the heater PCB is mounted to the cover.

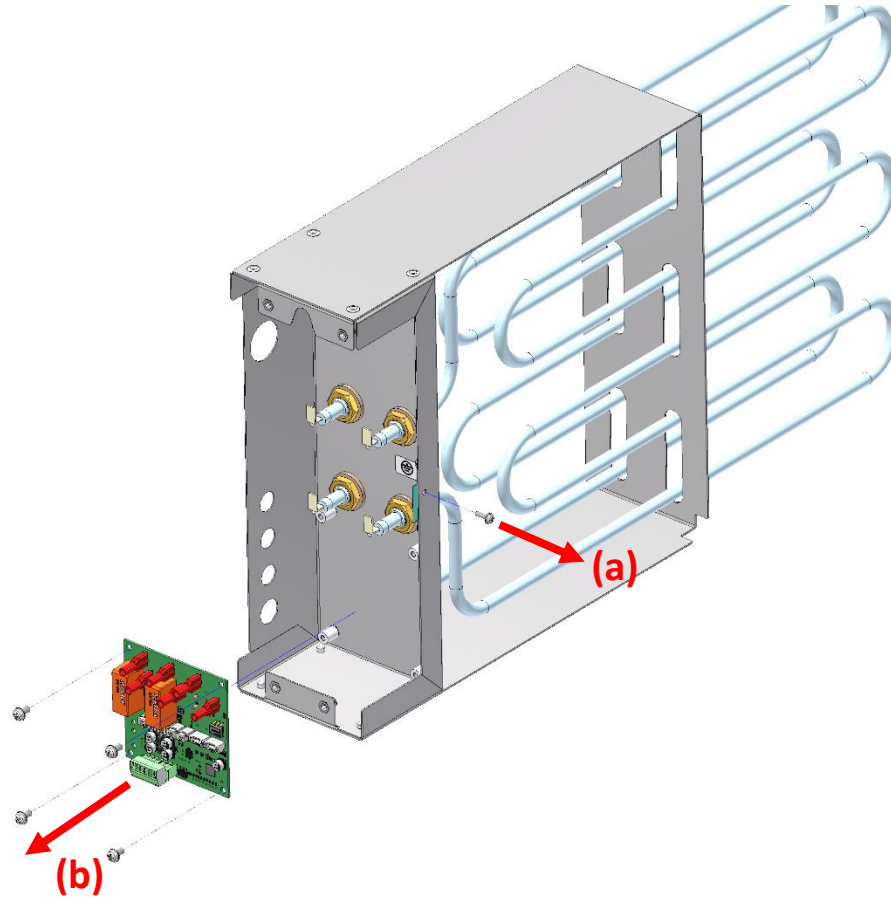

Note:

The heater carriage can be partially withdrawn to give better access. **Do NOT strain the cables.**

Replacement:

1. Align the new PCB with the standoffs, ensuring the PCB is oriented with the spade terminals at the top, and the 6-way green connector at the bottom. Secure with retained fixings.
2. Align the Triac with its fixing hole and refit the fixings. Ensure the legs point downwards and the wires are not snagged.
3. Reconnect all cables and connectors to the PCB as shown in the diagram below.

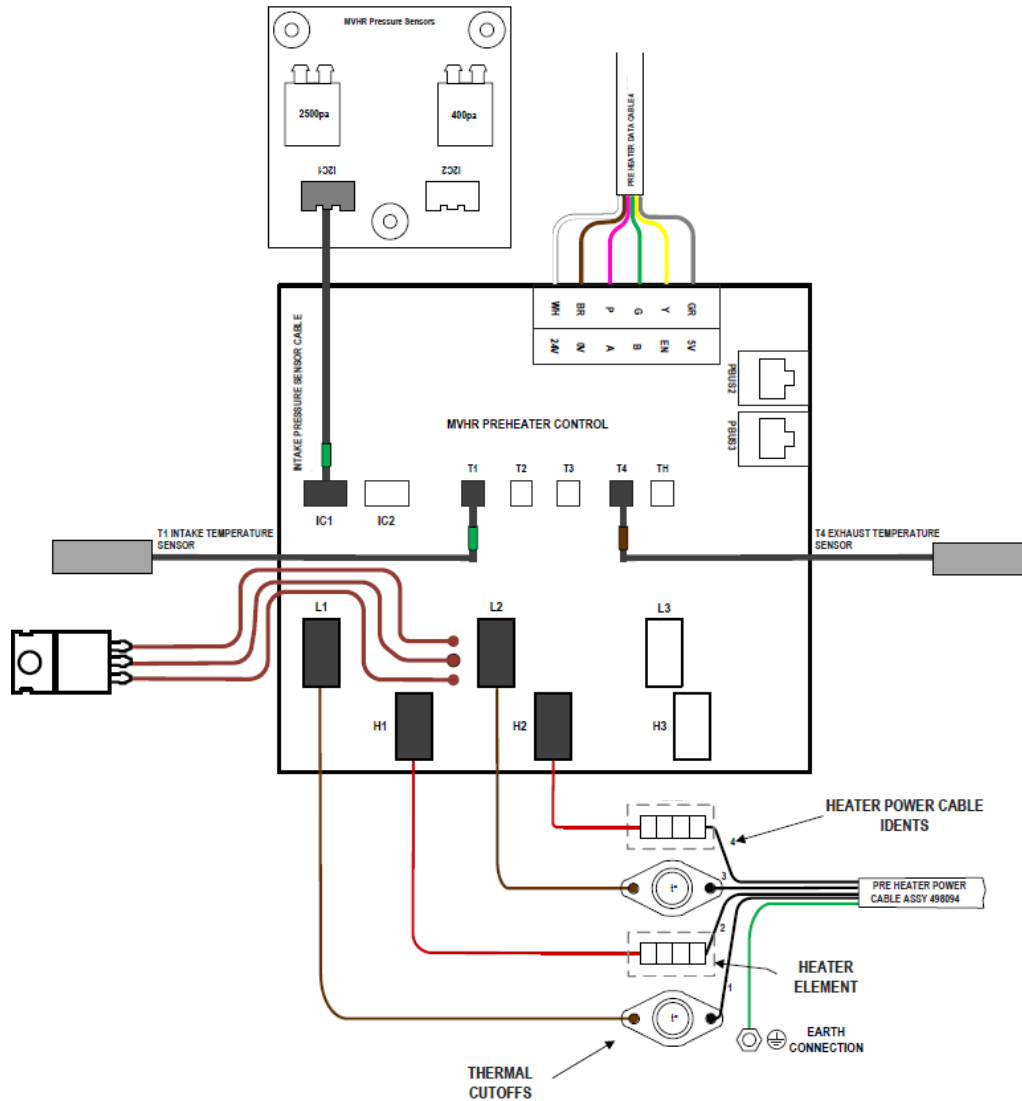

Overheat thermostats Resetting, Removal & Replacement

Resetting:

1. Turn off and isolate the unit, allow at least 30 seconds for fans to run down.

Remove the ambient end side access panel (see *Panel Removal/Replacement* section of this Manual) and heater assembly cover (see

Removal & Replacement of Parts

2. Pre-Heater Removal & Replacement section of this Manual, up to step 4).
3. Locate the thermostats at the top of the heater assembly. Press firmly the button on the back of the thermostat, a 'click' should be felt when it has reset.

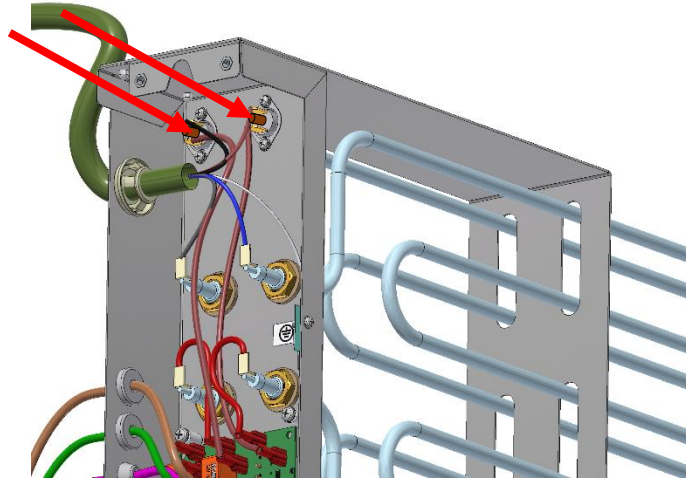

Removal:

1. Turn off and isolate the unit, allow at least 30 seconds for fans to run down.
2. Remove the ambient end side access panel (see *Panel Removal/Replacement section of this Manual*) and heater assembly cover (see

Removal & Replacement of Parts

3. *Pre-Heater Removal & Replacement* section of this manual, up to step 4).
4. Remove the spade connectors from each terminal on the thermostats.
5. Remove and retain 2No. fixings per thermostat then remove from heater assembly.

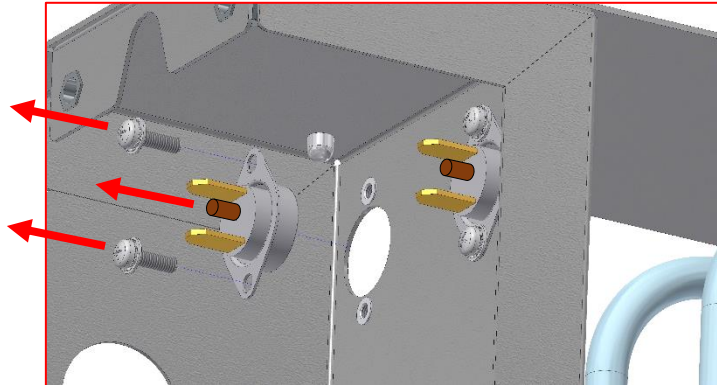

Replacement:

1. Place the new overheat thermostat into position, align the holes and refit the retained fixings.
2. Refit the spade connections, noting the cable idents. Refer to the diagram on the previous page.
3. Replace the ambient end side access panel (see *Panel Removal/Replacement* of this Manual) and heater assembly cover (see

4. *Pre-Heater Removal & Replacement* section of this Manual).

Note:

The heater carriage can be partially withdrawn to give better access.

Thermistors Removal & Replacement

Each Apex unit is fitted with 5No. thermistors, one in each of the 4 spigots, and one in the airpath between the intake motor and the cell. All thermistors are of the same type/construction with varying cable lengths. A coloured band at the connector end of the cable identifies the thermistor. The image below shows the routes which each thermistor takes.

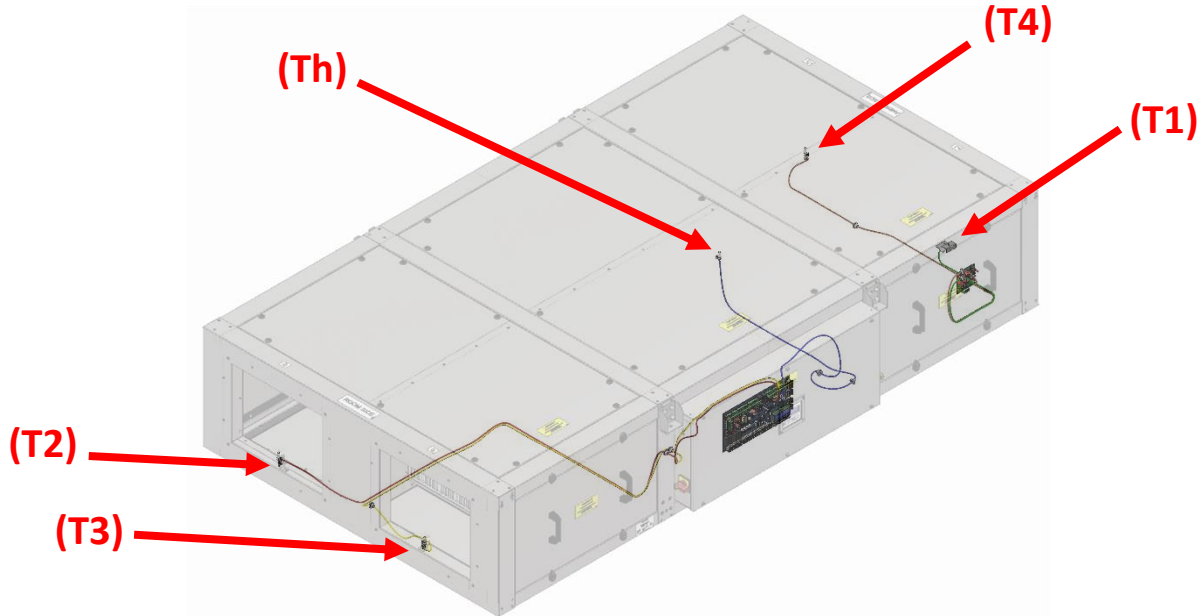

	T1	T2	T3	T4	Th
Colour	Green	Red	Yellow	Brown	Blue
Method of Access	Via T1 Spigot. (Panel access is obstructed by heater)	Room side top, bottom, or far side panel.	Room side top, bottom, or side access panel.	Ambient side top, bottom, or far side panel.	Ambient side top or bottom panel.
Connector location	Pre-heater PCB	Main Control PCB	Main Control PCB	Pre-heater PCB	Main Control PCB

Removal:

1. Turn off and isolate the unit, allow at least 30 seconds for fans to run down.
2. Remove the required panels to access the thermistor due to be replaced (See *Panel Removal/Replacement* section of this manual).
3. If removing/replacing T2, T3, or Th thermistors from above, the cells also require removal (See *Heat Exchanger Removal & Replacement (Roof-Mounted)* section of this Manual).
4. Locate the thermistor (white cylinder) at one end of the cable and push it out of its mounting clip.
5. Trace the route of the cable, cutting any cable ties as required, to the PCB end. Unplug the connector from the PCB. (Note some cable ties hold more than one cable)
6. Where fitted, push the grommets out of the sheet metal. (Note: The maximum number of grommets fitted to any thermistor cable is two).

Replacement:

1. Place the new thermistor and cable into the unit, push grommets through the sheet metal where required.
2. Route the thermistor to its mounting clip and push it in.
3. Route the cable along the original path back to the PCB. Plug in the connector to the PCB terminal.
4. Refit any cable ties which were removed. (Note: some cable ties hold more than one cable)
5. Refit the panels.

List of Spares

The table below lists the spares for the Sentinel Apex HR06X, HR10X, HR15X & HR21X:

Description	Part Number (HR06X)	Part Number (HR10X)	Part Number (HR15X)	Part Number (HR21X)
MOTOR ASSEMBLY SPARE (1 Motor)	497226	497227	497228	497229
MAIN PCB ASSEMBLY SPARE	497238	TBC	TBC	TBC
REMOTE HMI & WALL MOUNTING KIT APEX	412550			
POWER SUPPLY PCB SPARE	N/A	N/A	N/A	TBC
FILTER PACK M5 & F7	498470	498471	498472	498473
CONDENSATE PUMP SPARE	497244			
CONDENSATE SENSOR SPARE	TBC			
PRESSURE SENSOR PCB SINGLE	TBC			
PRESSURE SENSOR PCB DUAL	TBC		TBC	
ACTUATOR KIT SPARE				
HEATER PCB SPARE	497237			
OVERHEAT THERMOSTAT SPARE	TBC			
THERMISTOR PACK (T1, T2, T3, T4, Th)	497239	497240	497241	497242

*If the unit is a single stage filter system a Fine filter must be fitted to the Intake and a Coarse filter on the Extract. If a separate filter is fitted to the intake duct a coarse filter may be used on both Airpaths. This should be set on the unit firmware.

For an up-to-date list please ensure you review the latest version of this Manual available on our website under the product page and downloads. Alternative contact Technical Support, contact details can be found on the last sheet of this Manual.

Troubleshooting

Diagnosing a Problem

In the event of a problem, always troubleshoot the unit according to:

- **Status LED** above the on-board HMI and the bottom of the Remote HMI.
- **Diagnostic code** displayed on the Remote HMI, Onboard HMI and Vent-Axia Connect App.
- **Check Fuses** on the Main Control PCB.
 - **F1** – 2A T 250V
 - **F2** – 8A M 250V

Status LED

The Status LED flashing **RED** indicates a fault occurring on the unit. There are two flash patterns:

- **Fast Flash** - 2 Flashes every 1 second, contact Technical Support. (Contact details on final page)
- **Slow Flash** - 1 pulse every 5 seconds, Check HMI for Diagnostic Codes.

Diagnostic Codes

For assistance contact the service provider and quote the fault code number and the product serial number which can be found on the Unit Data Plate.

Fault Codes	
ID	Cause
F-1	Intake Thermistor
F-2	Extract Thermistor
F-3	Supply Fan
F-4	Extract Fan
F-5	Condensate Pump
F-6	Tamper Switch
F-7	Preheater Fault
...	
F-32	HMI Comms Lost

Warning Codes	
ID	Cause
W-1	Supply Temperature
W-2	Exhaust Temperature
W-3	Preheater Temperature
W-4	Intake RH
W-5	Extract RH
W-6	Supply Flow
W-7	Extract Flow
W-8	Filter Sensor 1
W-9	Filter Sensor 2
W-10	System Over-pressure
W-11	Preheater Tripped
W-12	Filter Clean Overdue
W-13	Service Overdue
W-14	Networked Device Lost
W-15	BMS Offline
W-16	Supply Fan Modbus
W-17	Extract Fan Modbus
W-18	Bypass/Cell Efficiency
W-19	Preheater I/O Offline

Notification Codes	
ID	Cause
N-1	Filter clean / replacement due soon
N-2	Networked Device Lost

Note:

- The fault code is not displayed until the fault has been present for 3 minutes.
- There may be new fault codes not listed here, please ensure that you always review the latest F&W available on our website under the product page and downloads.

Power Supply Troubleshooting

Troubleshoot according to the fault symptoms. If the fault cannot be rectified, contact your local dealer or sales office for a service engineer.

Table 6: Power Supply Troubleshooting

Symptom	Possible Problem	Action
No Power Supply (unit dead)	External Power Supply Failure	Check external power source is available and switched on.
	RCD Tripped	Check RCD on the DIN rail. Replace/reset if necessary.
	Main Controller PCB Fuses	Check fuses on the Main Controller PCB and Power Supply PCB
	Other	Contact Vent-Axia Technical Support.
No 24 V supply (at sensors/switches)	Fuse F1	Check fuses on the Main Controller PCB.
	Main Controller PCB	Contact Vent-Axia Technical Support.

Airflow Troubleshooting

Troubleshoot according to the fault symptoms. If the fault cannot be rectified, contact your local dealer or sales office for a service engineer.

Table 7: Airflow/Temperature Troubleshooting

Symptom	Possible Problem	Action
No airflow	Settings	Check the Commissioning Interface Status LED and display screens for alarm indications/messages.
	Motor	Check operation of the motors. Check HMI for taco readout.
	Condensate sensor alarm level	Check if high condensate level alarm is present. Check sensor and pump operation.
	Ducting	Check that ducting has not become loose or disengaged at any point along the airflow.
Max Airflow	Settings	Check the Commissioning Interface Status LED and display screens for alarm indications/messages.

Temperature Troubleshooting

Troubleshoot according to the fault symptoms. If the fault cannot be rectified, contact your local dealer or sales office for a service engineer.

Table 8: Temperature Troubleshooting

Symptom	Possible Problem	Action
Too Low	Pre-heater not turning on	Check circuit breakers. Check operation of thermistors and preheater. Check Commissioning Interface Status LED and display screens for alarm indications/messages.
	Summer bypass stuck open	Check position of summer bypass. Check operation of actuator.
Too High	Sensor incorrect signal	Check operation of thermistors and heater control board. Check Commissioning Interface Status LED and display screens for alarm indications/messages.
	Summer bypass stuck closed	Check position of summer bypass. Check operation of actuator.

Condensate Troubleshooting

Troubleshoot according to the fault symptoms. If the fault cannot be rectified, contact your local dealer or sales office for a service engineer.

Table 9: Condensate Troubleshooting

Symptom	Possible Problem	Action
Condensate water not being pumped out/water dripping from unit.	Condensate Sensor	Check position of sensor. Check operation of the sensor sitting in the condensate tray. Replace if necessary.
	Pump	Check the operation of the pump. Replace if necessary.
	Internal Pipe Damaged/Split	If the sensor and pump are both operational, check that the pipe carrying the water to the pump is not split, disconnected or kinked. Replace if necessary.
	External Pipe frozen	Fit insulation or a proprietary frost pipe heater.
	Other	Contact Vent-Axia Technical Support.
Pump running continuously	Pump	Check the signal connections to the pump. Replace pump if necessary.
	Condensate Sensor	Check the operation of the condensate sensor. Replace if necessary.
	Other	Contact Vent-Axia Technical Support.

Appendices

Appendix A: Glossary

The following technical terms and abbreviations are used in this manual.

Term/Abbreviation	Description
AC	Alternating Current
BSRIA	Building Services Research and Information Association
Cct	Circuit
CO2	Carbon Dioxide
DC	Direct Current
D-ERV	Demand Energy Recovery Ventilation
DIN	Deutsches Institut für Normung
HMI	Human Machine Interface
HR	Heat Recovery
IP	Ingress Protection
ISO	International Organization for Standardization
LED	Light Emitting Diode
MVHR	Mechanical ventilation Heat Recovery
PCB	Printed Circuit Board
PIR	Passive Infrared
PSU	Power Supply Unit
SRL	Sound Research Laboratories
TVOC	Total Volatile Organic Compounds

Appendix B: Options and Accessories

The following options and accessories are available for the Sentinel Apex.

No.	Item	Part Number			
		HR06X	HR10X	HR15X	HR21X
Ducting Accessories					
1.	Attenuator 900mm	ATT900-HR06	ATT900-HR10	ATT900-HR15	ATT900-HR21
2.	Attenuator 1200mm	ATT1200-HR06	ATT1200-HR10	ATT1200-HR15	ATT1200-HR21
3.	Attenuator 1500mm	ATT1500-HR06	ATT1500-HR10	ATT1500-HR15	ATT1500-HR21
4.	Duct mounted Rectangular electric heater with controls	EHB-HR06	EHB-HR10	EHB-HR15	HWB-HR21
5.	Duct mounted Rectangular LPHW heating battery	HWB-HR06	HWB-HR10	HWB-HR15	EHB-HR21
6.	Duct mounted Rectangular water-cooling battery	CWB-HR06	CWB-HR10	CWB-HR15	CWB-HR21
7.	Roof Assembly	WRF-HR06	WRF-HR10	WRF-HR15	WRF-HR21
8.	Intake / Exhaust Cowl	497213	497214	497215	497216
9.	Flexible Connection	497018	497019	497020	497021
10.	Transformation Piece	497222	497223	495296	497224
Sensors					
11.	0-10V – Internal Temp and Humidity - Wired				496428
12.	0-10V CO2 – Temperature and Humidity - Wired				496432
13.	240V – Internal Temperature and Humidity - Wireless				496429
14.	240V CO2 – Temperature and Humidity - Wireless				496433
15.	240V PIR Sensor – Wireless				496438
16.	240V – 4 Speed Switch with Temperature and Humidity - Wireless				496620 (White) 497693 (Black)
17.	240V – 4 Speed Switch with Temperature and Humidity - Wired				496621 (White) 497697 (Black)
18.	240V – AIM Alarm Interface Module including Temperature and Humidity - Wireless				496441

Appendix C: Main Controller PCB Terminals

The following table details the terminals on the Main Controller PCB.

Name	Description
MAINS	Factory wired to the DIN rail mains
MOTOR 2	Factory wired to extract fan
MOTOR 1	Factory wired to supply fan
CONTROL 2	Factory wired to extract fan
CONTROL 1	Factory wired to supply fan
PERIPHERALS	OUT1 – Factory wired to preheater controller OUT2 – Spare JP2 – Leave jumper fitted for 120 ohm termination when OUT2 not in use.
SUPERVISION	IN1 – Factory wired to condensate pump IN2 – Factory shorted (or to tamper switch if fitted)
SUMMER BYPASS	Port 1 – Factory wired to summer bypass Port 2 – Not used
DAMPERS	OP – switched 0V, active when backdraught dampers are being opened. 24V – permanent 24V supply to damper CL – switched 0V, active when backdraught dampers are being closed
BMS	5V – available for RS485 bus biasing (if required) 0V – for screening data cable (recommended attached one end only) A/B – differential RS485 data-pair to connect to Building Management System JP1 – leave jumper fitted for 120 ohm termination
SENSOR BUS	5V – Available for RS485 bus biasing (if required) 0V – For screening data cable or bus biasing (if required) A/B – Differential RS485 data-pair to connect to remote HMI and networked sensors. JP3 – Leave jumper fitted for 120 ohm termination
POWER OUT	24 V supply available
DIGITAL INPUTS	5V – power to switch SW – digital signal from switch (short to 5V to activate) 0V – ground reference (if required)
PROPORTIONAL INPUTS 0-10V	24V – power supply to room sensor PI – 0-10 V sensor input 0V – power supply return from return sensor
PROPORTIONAL OUTPUTS 0-10V	Reserved for future use (RFU) PO1 may be factory wired to summer bypass
RELAY 1	Relays may be custom configured for either: <ul style="list-style-type: none"> • Disabled • Attention Ventilation • Heating / cooling enable (controlled externally) • Controlled heating / cooling (controlled by MVHR)
RELAY 2	
RELAY 3	
RELAY 4	

Appendix D: Modbus Registers

RS485 settings can be set via the Vent-Axia Connect App or the on-board HMI

Register Map

Input Registers	Description	Unit
30001	Run time	uint16 days
30002	Service timer	uint16 months remaining
30003	Filter timer	uint16 months remaining
30004	Faults present h	uint32 bitmask
30005	Faults present l	
30006	Warnings present h	uint32 bitmask
30007	Warnings present l	
30008	Notifications present h	uint32 bitmask
30009	Notifications present l	
30010	System power	uint16 W
30020	Attention Ventilation LED output	bool
30021	Cooling enable output	bool
30022	Preheater enable output	bool
30023	<i>Other output sources...</i>	bool
30100	Intake duct temperature T1	int16 °C x10
30101	Intake duct RH	uint16 %
30102	Intake duct CO2	uint16 PPM
30110	Supply duct temperature T2	int16 °C x10
30120	Extract duct temperature T3	int16 °C x10
30121	Extract duct RH	uint16 %
30122	Extract duct CO2	uint16 PPM
30130	Exhaust duct temperature T4	int16 °C x10
30200	Zone 0 Temperature	int16 °C x10
30201	Zone 0 RH	uint16 %
30202	Zone 0 CO2	uint16 PPM
30210	Zone 1...	
30220	Zone 2...	
30230	Zone 3...	
30240	Zone 4...	
30250	Zone 5...	
30260	Zone 6...	
30270	Zone 7...	
30280	Zone 8...	
30290	Zone 9...	
30300	Zone 10...	
30310	Zone 11...	
30320	Zone 12...	
30330	Zone 13...	
30340	Zone 14...	
30350	Zone 15...	

Holding Register	Description	Unit
40001	Virtual Input 1	
40002	Virtual Input 2	
40003	Virtual Input 3	
40004	Virtual Input 4	
40005	Virtual Input 5	
40006	Virtual Input 6	
40007	Virtual Input 7	
40008	Virtual Input 8	
40009	Virtual Input 9	
40010	Virtual Input 10	
40020	BMS Shutdown	
40030	User Override	
40040	Machine Date - Year	uint16
	Machine Date - Month/Day	2x uint8
	Machine Time - hh:mm	2x uint8

Attribute	Default Value
Address	2
Baud Rate	115200
Parity	No Parity

Appendix E: Commissioning Record

Record the unit commissioning settings here.

Unit Serial Number (SN) (This 8 digit number can be found on the rating label)

Week		Year		Unique Number			

Date	Commissioning Setting			Engineer/Technician
		Supply	Extract	
	Normal	%	%	
	Boost	%	%	

Date	Commissioning Setting			Engineer/Technician
		Supply	Extract	
	Normal	%	%	
	Boost	%	%	

Date	Commissioning Setting			Engineer/Technician
		Supply	Extract	
	Normal	%	%	
	Boost	%	%	

Date	Commissioning Setting			Engineer/Technician
		Supply	Extract	
	Normal	%	%	
	Boost	%	%	

Date	Commissioning Setting			Engineer/Technician
		Supply	Extract	
	Normal	%	%	
	Boost	%	%	

Date	Commissioning Setting			Engineer/Technician
		Supply	Extract	
	Normal	%	%	
	Boost	%	%	

Date	Commissioning Setting			Engineer/Technician
		Supply	Extract	
	Normal	%	%	
	Boost	%	%	

Appendix F: Additional Technical Data

Summer Bypass Mode

The MVHR includes an intelligent Summer Bypass (SBP) feature, this bypasses the heat exchanger when necessary to provide free cooling, this is triggered when the desired Indoor Temperature is above the ambient temperature.

Note that the volume of air provided by a ventilation system is a fraction of that required for space heating or space cooling and will not in itself be sufficient to cool a room. It will however provide a contribution.

Modes of operation

Bypass Mode	Operation
Off	Summer Bypass feature is disabled, Bypass will be active during Anti-frost
Normal	The unit will run on Normal Mode, unless cancelled
Evening Fresh	The unit will run on the user selected Mode for 5-hours before reverting to Normal, unless cancelled
Night-Time Fresh*	The unit will run at the user selected Mode, unless cancelled

Bypass mode will operate when both the Indoor and Outdoor temperature thresholds are exceeded, and the outdoor temperature is below the indoor temperature.

Indoor Temp: This is the maximum desired indoor temperature. Above the set indoor temperature, the summer bypass will operate.

Indoor temp should be set, 2-3°C higher than the central heating thermostat to prevent the bypass operating in winter, and 2-3°C lower than any air conditioning thermostat if fitted.

Outdoor Temp: This is the minimum allowed outdoor air temperature. The air temperature must be above this value for the Bypass to operate, use this value to prevent the bypass operating in winter.

The suggested Outdoor Temp, is 14°C, set as appropriate for your region.

Bypass mode will be cancelled when either:

- The internal air temperature drops below the Indoor Temp threshold, or
- The external air temperature drops below the Outdoor Temp threshold

It is recommended that the user selected mode chosen for Evening Fresh and Night-Time Fresh is higher than Normal flow rate to reduce the indoor temperature more rapidly.

*Night-Time Fresh Mode is intended for use through the night when cooling is a higher priority than any increase of noise. Note, that the air noise in your system is influenced by flowrate, ducting design, layout and the size and type of vents used in the rooms. If improvements are required, please contact your installer.

Flow Rate Settings

The Unit has four (4) user defined speeds, which are adjustable in the advance setting menu or via the App. The speed mode names are customisable via the App.

Default speed modes names: -

- Low
- Normal (Unit default operating mode)
- Boost
- Purge

Frost Protection

Frost Protection is required to prevent condensate freezing in the heat exchanger at low temperatures. The process is fully automatic. The method used for frost protection will depend on the model and building it is installed in.

For buildings with a leak rate of 3m³/hr or less (at 50Pa), a balanced frost protection mode must be used. A balanced mode must also be used when a combustion device without a dedicated air supply is present.

Airflow (Imbalanced)

Airflow mode reduces the Intake flow and increases the Extract flow in varying proportions dependent on the incoming air temperature. The unit will continue to recover heat as low as “-20°C”. At this point, the unit switches to 'Extract Only' mode.

Bypass (Balanced)

Bypass mode opens the Summer Bypass and stops recovering heat until the external temperature increases sufficiently.

Airflow & Preheater (Imbalanced)

If a preheater is fitted, the preheater will turn on to warm the incoming air to above freezing. If the air temperature is so low that the heater cannot warm the air sufficiently, the supply flow rate will be reduced to compensate.

Airflow & Preheater (Balanced)

If a preheater is fitted, the preheater will turn on to warm the incoming air to above freezing. If the air temperature is so low that the heater cannot warm the air sufficiently, both the supply and extract flow rate will be reduced to compensate.

Intentionally Blank

Disposal



This product should not be disposed of with household waste.

Please recycle where facilities exist. Check with your local authority for recycling advice.

The **Vent-Axia** Guarantee

Applicable only to products installed and used in the United Kingdom. For details of guarantee outside the United Kingdom contact your local supplier.

Vent-Axia guarantees its products for five years from date of purchase against faulty material or workmanship. In the event of any part being found to be defective, the product will be repaired, or at the Company's option replaced, without charge, provided that the product: -

- Has been installed and used in accordance with the instructions given with each unit.
- Has not been connected to an unsuitable electricity supply. (The correct electricity supply voltage is shown on the product rating label attached to the unit).
- Has not been subjected to misuse, neglect or damage.
- Has not been modified or repaired by any person not authorised by the company.

IF CLAIMING UNDER TERMS OF GUARANTEE

Please return the complete product, carriage paid to your original supplier or nearest Vent-Axia Centre, by post or personal visit. Please ensure that it is adequately packed and accompanied by a letter clearly marked "Guarantee Claim" stating the nature of the fault and providing evidence of date and source of purchase.

Vent-Axia

Head Office: Fleming Way, Crawley, West Sussex, RH10 9YX

EU Authorised Representative: Vent-Axia Sigarenmaker 5 - 5521DJ Eersel Nederland authorisedrep@vent-axia.nl

UK NATIONAL CALL CENTRE: -

Sales Enquiries: Tel: 0344 8560590

Email: sales@vent-axia.com

Technical Support: Tel: 0344 8560594

Email: vatechsupport@vent-axia.com