

NVHRe - Setting the standard for a sustainable future.

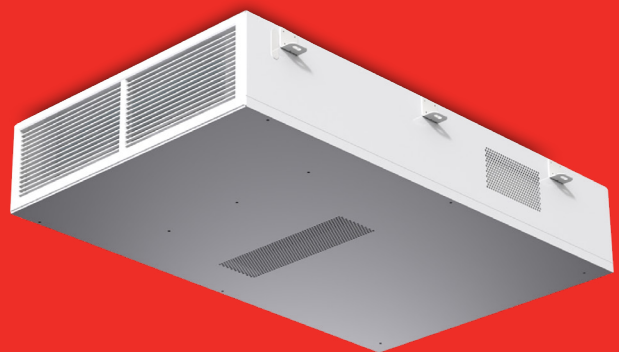

Natural Ventilation units
utilising hybrid technology
to deliver Heat Recycling
and Heat Recovery with
maximum energy efficiency.





**Focused on helping
you create a healthy
indoor environment
with the lowest
energy, CO₂ and
capital cost.**

Leading provider of quality built, controlled hybrid ventilation systems



Breathing Buildings is a UK manufacturer whose mission, since we established in 2006, is to help clients create the lowest energy building possible with minimum associated CO₂ emissions and capital cost. Our energetic team of ventilation specialists are focused on providing the highest level of ventilation and thermal comfort of buildings nationwide, throughout all the challenges of the British seasons and in compliance with all relevant industry standards.

We pride ourselves on being the construction industry's leading provider of quality built, controlled hybrid ventilation systems. Our product range includes the industry renowned and patented E-Stack[®] roof top ventilation units and the Award winning NVHR[®] range of Natural Ventilation units with Heat Recycling. These units have helped drive the change in how the UK construction industry thinks about low-energy ventilation solutions in commercial buildings.



Energy efficient Natural Ventilation units with Heat Recovery, designed and built in Britain to help you achieve your net zero carbon emissions.

Our team believe that the preservation of our environment is not simply a necessary business objective but it is our responsibility, both commercially and personally. The Government has set clear targets for companies to work towards, so whether you are focused on reducing your carbon footprint or achieving net zero carbon emissions by 2050, our new NVHRe Heat Recovery system is designed to firmly place you on the road to meeting your goal. We are not just passionate about ensuring a happy, healthy environment for the future - we specialise in it.

Key components are British made which ensures several benefits including minimum carbon footprint of transported components and fast lead times as we are not reliant on materials being supplied internationally. A further benefit is the assurance of the very best quality.

Furthermore, key components utilise advanced technology to ensure their energy efficiency such as the twin fan deck and the centrifugal backward curved motors that deliver high energy efficiency thanks to the incorporated EC technology.





**Sustainability
takes more than
responsible
manufacturing**

Sustainability benefits were key at every stage of the product design

Our popular industry award winning Natural Ventilation unit with Heat Recycling (NVHR) is performing as designed in hundreds of commercial buildings nationwide. It has become particularly popular in Schools, Colleges and Universities as they require low energy, fresh air ventilation all year round to keep their students happy, healthy and focused.



Benefits of the inclusion of a Heat Exchanger.

The key difference between the NVHR units and the new Natural Ventilation with Heat Recycling and Heat Recovery (NVHRe) units is the addition of a heat exchanger cell within the unit. The continuous increase in the cost of energy has put organisations under immense pressure to find ways of significantly reducing the energy consumed by their building whilst also ensuring superior indoor air quality to keep occupants comfortable, healthy and productive. Adding a heat exchanger cell provides the heat recovery function. Reclaiming even more heat than other models, provides significant benefits in terms of energy saving and occupant comfort. It also enables you to include it within your building's energy assessments (SBEM).

The NVHRe is ideally suited to a diverse range of commercial buildings with high heat gains, generally associated with multiple occupants or equipment. Typical applications include Schools and Colleges, Leisure Centres and Libraries, Offices, Theatres and even Churches.

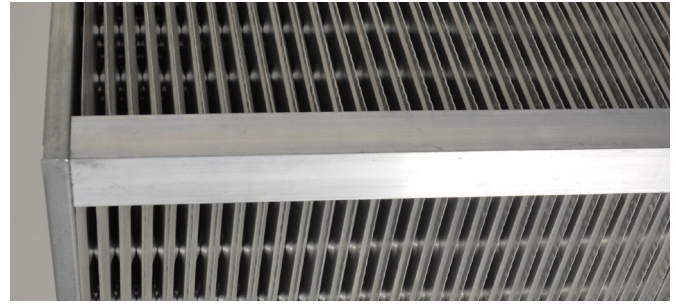

Aluminium cross flow plate heat exchanger

The inclusion of a heat exchanger within the NVHRe provides the ability to actively recover heat that would otherwise be wasted. Heat Recovery, along with low specific fan power, benefits the building owner in terms of both energy efficiency and cost by reducing the reliance on space heating systems to maintain the thermal comfort within the room.

The heat exchanger utilised in our NVHRe is an aluminium cross flow plate heat exchanger. It has a galvanised casing and an aluminium plate heat exchanger surface.

It is utilised during colder external temperatures, typically where it is lower than 7°C and mixing alone isn't enough to maintain the desired temperature of the air delivered to the occupants. This is called the Winter Heat Recycling and Heat Recovery mode. We can utilise the heat exchanger technology on demand. The cold air coming into the building crosses over the heat exchanger before being further mixed with a portion of room air before being delivered to the space as a tempered fresh air supply.

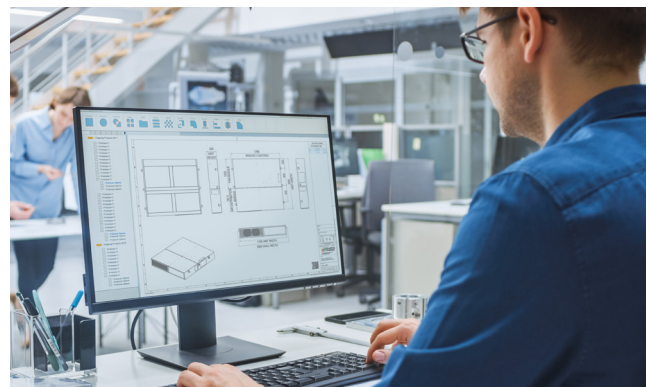

The NVHRe can help you meet your buildings objectives and contribute to the Life Cycle Assessment (LCA) of your Building.

- It is the most energy efficient, Hybrid Heat Recovery unit in the industry
- It delivers an impressive 46% heat recovery efficiency and has extremely low Specific Fan Power (SFP)
- It has the lowest industry energy consumption with an SFP of 0.075 W/l/s
- UK design and manufacture
- Provides excellent thermal comfort and enhanced indoor air quality
- Robust quality, built for longevity
- Incorporates high performing, energy efficient components
- All key components are recyclable
- Several operating modes including natural ventilation ensure energy consumption is kept to the absolute minimum with no need for mechanical operation
- The core of the unit is built with high grade EPP throughout

Delivering 46% heat recovery efficiency with extremely low Specific Fan Power levels to help you achieve your sustainability targets towards achieving Net Zero Carbon.

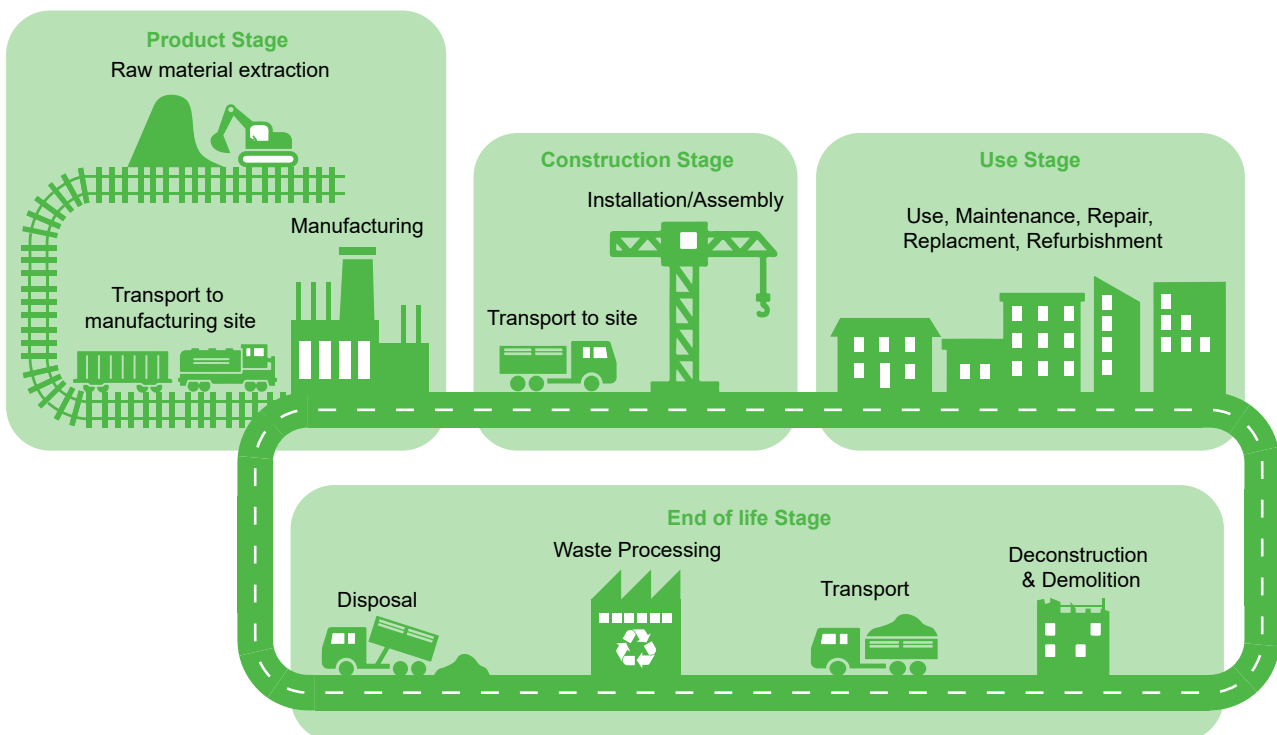
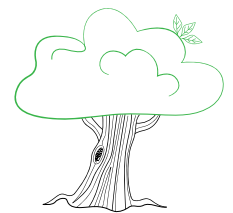

Life Cycle Assessment (LCA) of a Building - Sources of embodied carbon across the construction lifecycle

Industry leading NVHRe Range

The 'e' in the product code refers to the incorporation of a heat exchanger cell in the unit that contributes to the increase in energy efficiency. The + refers to the addition of a heating coil. The C refers to the addition of a cooling coil.

Our range of heat recovery units are aesthetically designed to meet the requirements of a variety of commercial applications and functions with a choice of concealed or exposed units as desired. Three models are in the range as summarised below. All three models share the same physical dimensions: 1100mm wide x 1800mm deep x 330mm high.

NVHRe 1100 Ventilation, Mixing and Heat Recovery



NVHRe+ 1100 Ventilation, Mixing, Heat Recovery and Heating Coil

NVHRe C+ 1100 Ventilation, Mixing, Heat Recovery, Heating and Cooling Coil

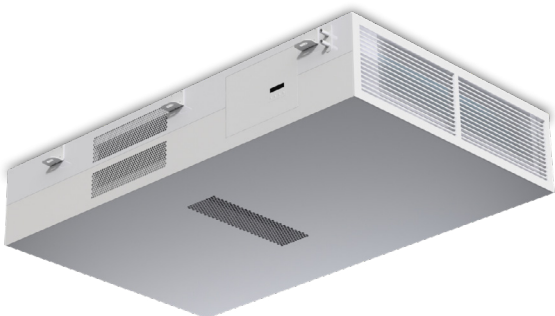

User friendly controls

The advanced connected controller has many features and is compatible with leading Building Management Systems. It utilises trusted algorithms and has a secure night cooling mode and enhanced features including a function for those with Special Educational Needs and Disabilities.

The interface provides greater flexibility to the user than ever before with a boost mode that is complaint with BB93 relating to noise regulations in Educational premises and sleep modes for a variety of periods to perfectly match the occupants preference and deliver the ideal thermal comfort.

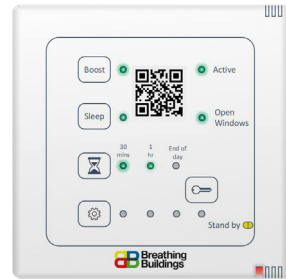

The unit is provided with an on-board text screen for ease of commissioning and fault finding. Even more benefits are added with this controller as you can commission the system via an App. The App takes you through a step-by-step process to ensure nothing is missed from installation to handover, ensuring that one of the most important stages of your project is smooth and efficient.



Model	NVHRe 1100	NVHRe+ 1100	NVHRe C+ 1100
Weight	85kg	89.5kg	90kg

All units are 1100mm wide x 1800mm deep x 330mm high.

Specification Data

The NVHRe delivers multiple benefits including an impressive 46% heat recovery efficiency in Winter thanks to the low resistance aluminium cross flow plate heat exchanger.

Working with the extremely low Specific Fan Power of just 0.075 W//s enables us to deliver you the most energy efficient, industry leading unit available.

Heating & Cooling Data

Model	Flow/Return	Output
NVHRe+ 1100	45/39	>5kW
NVHRe C+ 1100	6/12	2kW

Mode	NVHRe 1100				NVHRe+ 1100 & NVHRe C+ 1100			
	Total Flow Rate	Noise*	ESP	SFP	Total Flow Rate	Noise*	ESP	SFP
Summer	100 l/s	24	0	0.026	100 l/s	24	0	0.077
Summer	128 l/s	25	0	0.069	128 l/s	28	0	0.041
Summer	160 l/s	26	0	0.066	160 l/s	28	0	0.084
Summer	180 l/s	30	0	0.055	180 l/s	30	0	0.073
Mid Season	100 l/s**	28	2.3	0.028	100 l/s**	22	1.8	0.08
Mid Season	128 l/s**	32	4.1	0.071	128 l/s**	26	3.3	0.075
Mid Season	160 l/s**	35	5.9	0.075	160 l/s**	32	6.9	0.08
Winter	160 l/s**	34	0	0.075	160 l/s**	34	0	0.109
Night Cool	231 l/s	45	33.9	0.129	241 l/s	41	30	0.124

*The above Winter Mode and Summer Mode tables are based on our NVHRe 1100 grilled system. Predicted noise level based on two units in a 55m² Classroom with 0.4 reverberation time.

** Total flow rate based on a 1:1 mixing ratio of fresh air to recirculation air.

Annual Energy Consumption

Utilising our data, we have calculated the Annual Energy Consumption used by our NVHRe 1100 Grilled System.

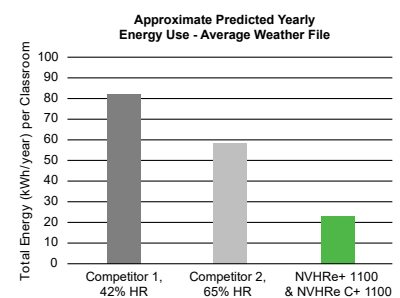
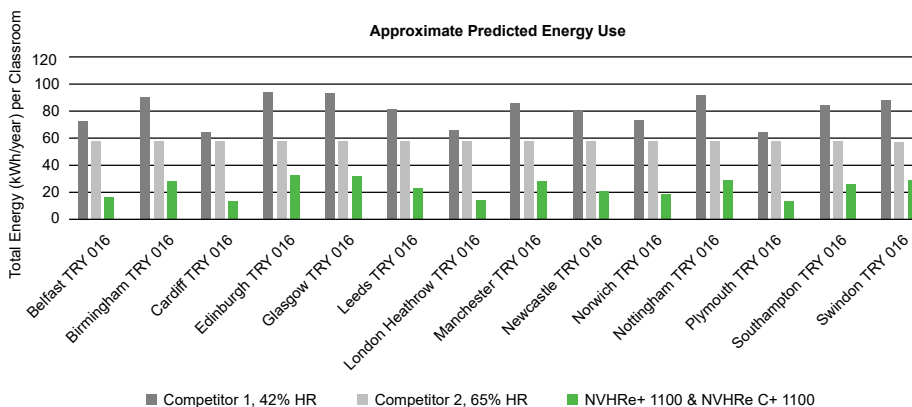
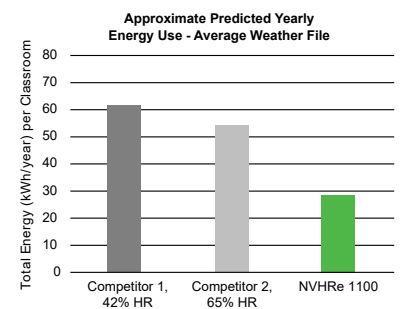
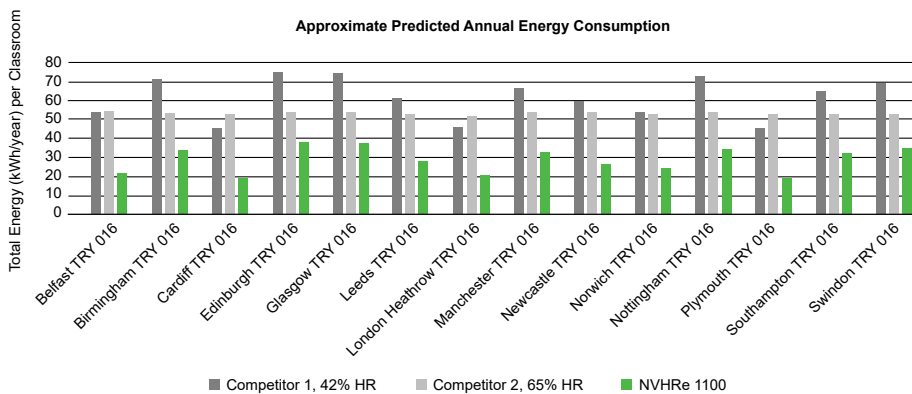

The above graphs are based on CIBSE TRY 2016 weather data, 128 l/s per system in Summer, 80 l/s per system in Winter, 2 units per classroom. Average of combined weather files across the UK, occupied hours, 9am - 4pm Weekends and school holiday periods have been excluded.

Compliance as standard

Achieving Net Zero carbon is a shared objective and core to the development of our NVHRe range which is why it is the most energy efficient solution available today. The entire range is fully compliant with all relevant legislation and guidance including:

- ✓ CIBSE TM52 – for the avoidance of overheating in naturally ventilated spaces
- ✓ BB101 – Government guidance on ventilation, thermal comfort and indoor air quality in Schools
- ✓ BB93 – Acoustic design of Schools, performance standards
- ✓ DfE Annex 2F – Department of Education guidance on Mechanical Services and Public Health Engineering
- ✓ Part F and Part L 2021 – Performance and SFP requirements

Enhanced Indoor Air Quality helps students maximise their potential

It is recommended to measure CO₂ levels in occupied spaces to ensure pollutants, including carbon dioxide and moisture, are controlled, and the indoor air quality is good. This is particularly important in educational facilities such as Schools, Colleges and Universities where students levels of concentration can be affected. Ask our team for more information on the Government guidance on ventilation, thermal comfort and indoor air quality in Schools and how our products can help you exceed these recommendations.

Design and maintenance benefits

The design of the units makes them ideal for use in a variety of commercial buildings with access to either a window or roof where the unit is to be installed. The aesthetics of the unit was a key consideration, the result is aesthetically pleasing units that are ideal for either an exposed or concealed ceiling application. Great consideration has also been given to the maintenance of the units. All core components in the unit including the heat exchanger, the twin fan deck and the motorised impellers are easily accessible. Access is gained from beneath the unit via a full width access panel that has toggle latches to facilitate its removal safely. The incorporation of a low resistance heat exchanger negates the need for filters.

The sustainability benefits don't end here.

Ease of maintenance of these core components ensures further sustainability benefits as each component can be serviced to ensure it operates efficiently and for as long as possible, enhancing the overall longevity of the unit. Units that contain components that are not easily accessible, can not be maintained and would therefore over time perform poorly. This results in the building owner having to completely replace the unit, causing unnecessary disruption to the building, creating waste and having an impact on the environment and landfill. Furthermore, it is very costly compared to having a maintenance contract to replace the units that would ensure the unit operates effectively for longer.





**Ease of maintenance
of core components
ensures further
sustainability benefits**

**Thanks to carefully crafted design,
the NVHRe units deliver high
performance and efficiency and in
addition, all key
components can
be recycled.**



Thanks to carefully crafted design, every key component within our NVHRe including the heat exchanger, the EC twin fan deck, the EC centrifugal backward curved motorised impellers and the high grade EPP are all recyclable. This was a fundamental focus for the design team who have truly delivered.

High grade EPP

The key structure of the product is the high grade EPP. This is carefully crafted to ensure the lowest acoustic sound is emitted from the unit.

This is recyclable.

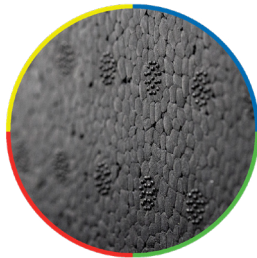

Energy efficient heat exchanger

The heat exchanger used in the NVHRe helps deliver the highest achievable energy efficiency of the unit.

This is recyclable.

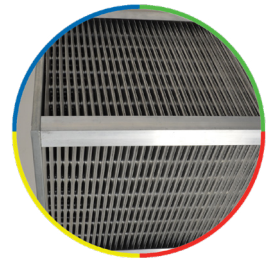

Condensation tray and pump

Condensation from the coil is gathered in the moulded EPP condensate tray that is within the NVHRe unit.

This is recyclable.



Centrifugal backward curved motor / extractor fan

The UK manufactured motor utilised advanced EC motor technology to achieve the highest energy efficiency.

This is recyclable.



Coil

The high quality coil provides either hot or cold water, or a combination of the two to the fan coil unit.

This is recyclable.



Twin fan deck / fresh air fan

The UK manufactured motor is built with quality and performance in mind. It helps deliver the highest achievable energy efficiency thanks to the EC motor technology.

This is recyclable.

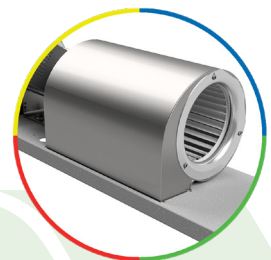

Quality steel construction

The body of the unit is constructed of the highest quality steel both beneath the unit and on all sides. A full width access panel is beneath the unit to ensure ease of maintenance on site.

This is recyclable.

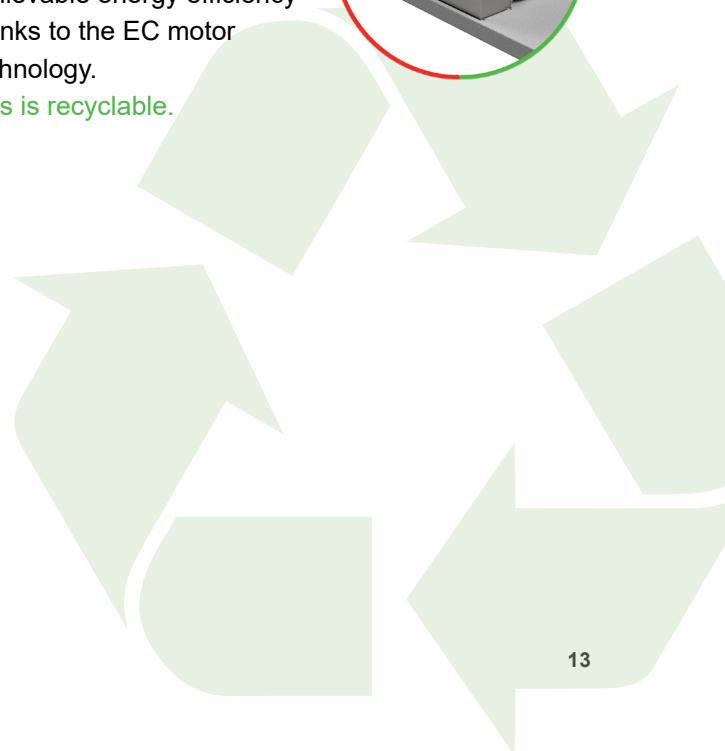

Delivering affordable comfort, all-year-round

The NVHRe has several different operating modes to ensure its suitability for all seasons. It has an operation to enhance indoor air quality and occupant comfort in the most energy efficient and convenient way. Being an intelligent hybrid system, the unit automatically decides when and if mechanical operation is required, ensuring the mechanical operation is minimised. The building owner still has the ability to over-ride the system for more or less ventilation as desired. Having this level of control helps to ensure the lowest cost ventilation for your building by reducing heating demand. The key operational modes are explained here.

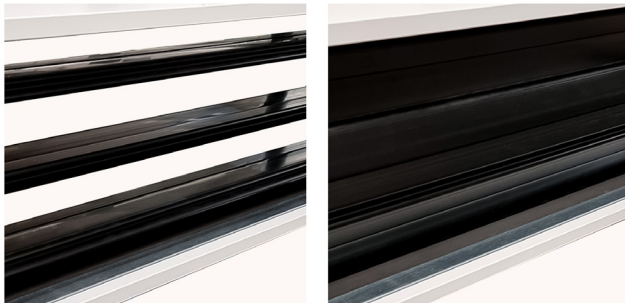

Damper open

Damper closed

In all modes, the high quality UK manufactured damper is connected to the exterior of the building and is either closed, open fully or modulates on demand depending on the requirements of the space. The damper offers exceptional U-Value and very low leakage benefits, which prevents heat loss and therefore ensures lower energy consumption.

The NVHRe units benefit from a large cross section area that allows the maximum amount of natural fresh air to flow into the building, and exhaust air to flow out of the building. This is a significant benefit as it avoids the need for mechanical operation, therefore fresh air is provided at the very lowest energy consumption.

A large cross section area reduces mechanical operation and keeps energy consumption to the minimum

Exhaust air extracted from inside the room, to the outside of the building

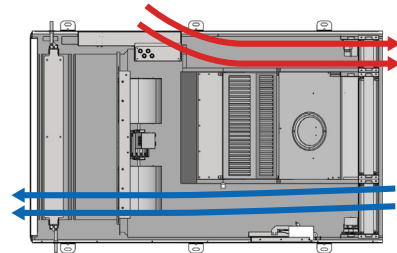

Fresh air from outside the building, brought into the room

The NVHRe in Summer, Mechanical Mode

In summer mode, the damper is fully open and can work in conjunction with other openings in the space, for example, windows, roof lights, dampers or similar to allow for a cross ventilation strategy within the space that offer a cross-ventilation strategy. There is also some mechanical operation as the fans operate to increase the flow of fresh air into the building. The fans ensure an increase in airflow within the space to increase thermal comfort for occupants during the hotter weather. The NVHRe C+ 1100 contains a cooling coil that can assist with occupant comfort in hotter days. This mode includes a secure night cooling operation, which enables exhaust air from inside the building to be extracted, this allows the cool night air into the building so a comfortable morning temperature is achieved.

Exhaust air extracted from inside the room, to the outside of the building

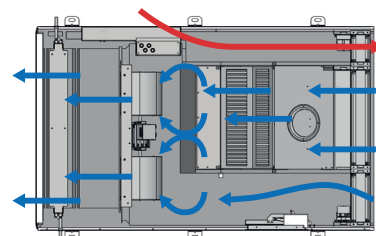

Fresh air is supplied to the room passively via other openings such as windows and is assisted by the NVHRe unit to distribute the air effectively throughout the room and further enhance occupants' comfort.

The NVHRe in Summer, Natural Mode

In natural mode, the damper is fully open and can work in conjunction with other openings in the space for example windows, roof lights, dampers or similar to allow for a cross ventilation strategy within the space that offer a cross ventilation strategy. In natural mode, there is no mechanical operation as the unit is utilising natural driving forces to its maximum benefit. A free running building, a cost saving operation.

Exhaust air extracted from inside the room, to the outside of the building.

Fresh air is supplied to the room passively via other openings such as windows before being exhausted passively via the NVHRe unit.

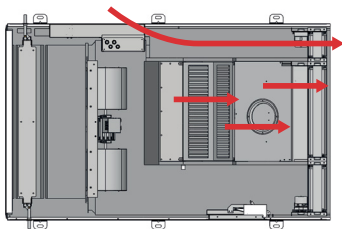

The NVHRe in Winter Mode

In winter mode, the damper modulates on demand. This mode utilises mechanical operation and benefits from a draught mitigation strategy, this mixes warm room air with fresh air coming into the space which creates a draft free and comfortable environment for occupants. During periods with colder external conditions, the addition of a cross flow heat exchanger can be used to temper incoming air before being further mixed downstream to maintain the delivered air temperature.

Winter Mode: Mixing

Stale air is exhausted passively from the room and discharged to the outside of the building.

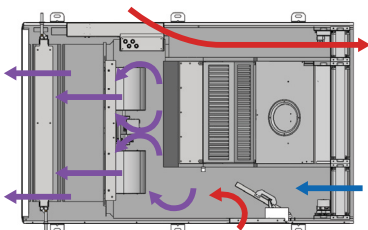

The damper is partially open, enabling incoming fresh air, whilst also preventing cold draughts. The mixing door is open, allowing room air to be re-circulated into the in-coming fresh air pathway. This results in tempered fresh, warmer air being supplied to the occupant, maintaining enhanced internal comfort and good indoor air quality.

Natural openings such as windows during this mode remain closed.

Winter Mode: Mixing with Heat Recovery

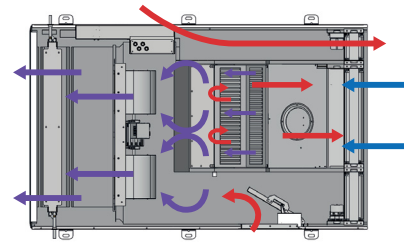

Stale, warm air is extracted from inside the room, and passed across the heat exchanger before being exhausted to the outside of the building.



Fresh air is supplied to the room by passing across the pre-warmed heat exchanger, which tempers the incoming air. The air is then mixed downstream of the heat exchanger with room air resulting in good indoor air quality and improved thermal comfort during the coldest external conditions.

Natural openings such as windows during this mode remain closed.

Key

-  The process of the air in heat recovery and/or heat recycling mode
-  Fresh air entering the building
-  Exhaust air leaving the building



1st Fix Wiring Diagram

NVHRe 1100

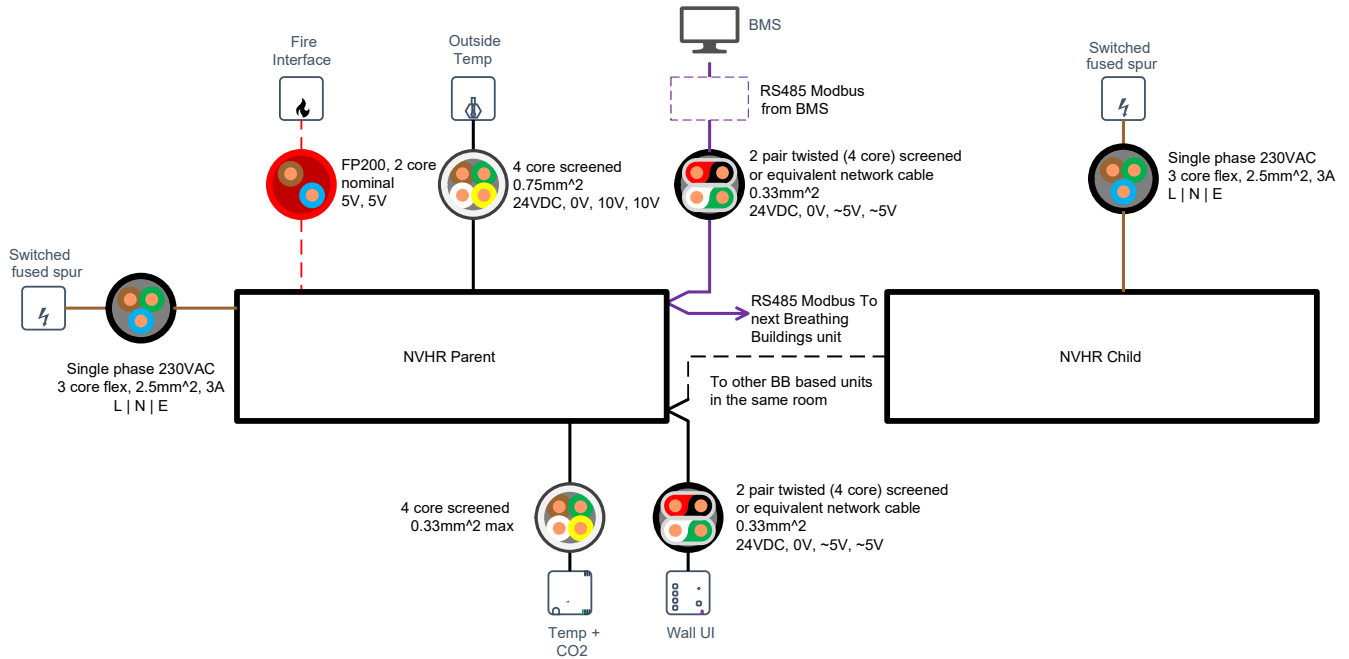

NVHRe+ 1100 & NVHRe C+ 1100

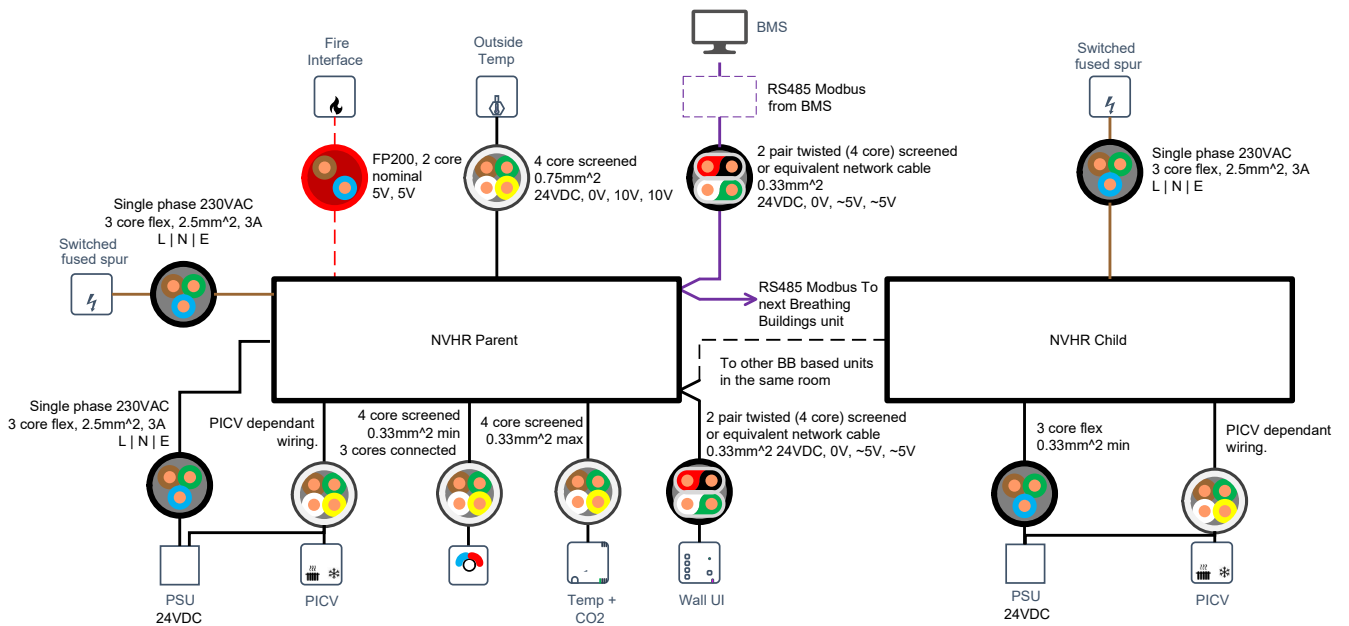



Our team are passionate about delivering the very best personalised service to our customers with emphasis on providing the ideal solution for your particular property needs. We will happily organise a free consultation at your convenience, to assess all of the ventilation options and ensure you are recommended the ideal solution that delivers enhanced indoor air quality, the best energy efficiency, ease of operation, internal comfort and peace-of-mind.

Our customers can be assured of our product quality, our processes and our excellent customer service. Breathing Buildings have won several industry awards. Three prestigious awards were won in 2022 for one project, ask our team to explain more about the East Anglian Air Ambulance project that won awards from the Chartered Institute of Building Services Engineers (CIBSE), Heating and Ventilating Review (HVR) and the Society of Public Architecture, Construction, Engineering and Surveying (SPACES) for our NVHR range and our close collaboration with customers.





Our team would welcome the opportunity of demonstrating our case studies to you and answering any questions you may have. Simply call 01223 450060 or email us at info@breathingbuildings.com and we will visit you at your convenience.

Contact our team for a free site consultation at your convenience.



QUALITY MANAGEMENT SYSTEM - ISO 9001:2015
OCCUPATIONAL HEALTH & SAFETY MANAGEMENT SYSTEM - ISO 45001:2018
ENVIRONMENTAL MANAGEMENT SYSTEM - ISO 14001:2015

 **Breathe Better
Build Sustainably****Contact us:**

-  www.breathingbuildings.com
-  info@breathingbuildings.com
-  01223 450060
-  Fleming Way, Crawley RH10 9YX
-  www.linkedin.com/company/breathing-buildings