



**CONFIDENTIAL**

**Report: Chilt/RF10167**

**A fire resistance test performed on ten duct penetration sealing systems within a flexible supporting construction**

**Test conducted in accordance with BSEN 1366-3: 2009 and BSEN 1363-1: 1999**

**Test date: 15<sup>th</sup> December 2010**

**Page 1 of 24**



**committed to excellence**

[www.chilternfire.co.uk](http://www.chilternfire.co.uk)

[www.chilterndynamics.co.uk](http://www.chilterndynamics.co.uk)

[www.qmark.info](http://www.qmark.info)

**Prepared for: Tenmat Ltd  
Ashburton Road West  
Trafford Park  
Manchester  
M17 1RU**



Opinions and interpretations expressed herein are outside the scope of UKAS accreditation. This document is confidential and remains the property of Chiltern International Fire Ltd. *The legal validity of this report can only be claimed on the presentation of the complete report.*



## Contents

	Page No
<b>1 Introduction .....</b>	<b>3</b>
<b>2 Specimen verification .....</b>	<b>3</b>
<b>3 Description of supporting construction .....</b>	<b>3</b>
<b>4 Description of specimen.....</b>	<b>3</b>
4.1 Ducts fitted through partition wall (see figures 1 - 4) .....	4
4.2 Duct seal specifications .....	5
4.3 Service penetrations supports .....	7
<b>5 Test conditions.....</b>	<b>9</b>
5.1 Furnace temperature .....	9
5.2 Pressure readings .....	10
5.3 Ambient temperature .....	10
5.4 Thermocouple positions .....	11
<b>6 Observations .....</b>	<b>12</b>
<b>7 Expression of results.....</b>	<b>14</b>
<b>8 Limitations .....</b>	<b>15</b>
<b>9 Photograph.....</b>	<b>16</b>
<b>10 Graphs .....</b>	<b>19</b>
<b>Appendix 1 – figures 1 – 5 .....</b>	<b>24</b>
<b>Appendix 2 - Raw test data (12 pages)</b>	

*The legal validity of this report can only be claimed on presentation of the complete report.*

## **1 Introduction**

Fourteen duct sealing systems, of which ten only are subject to this report, were installed into a flexible supporting construction and tested.

## **2 Specimen verification**

The specimens were delivered to Chiltern International Fire Ltd (CIFL) during December 2010. CIFL constructed a 130mm thick steel stud/plasterboard clad partition. The client then subsequently installed the systems into the supporting construction, with assistance from CIFL as required.

## **3 Description of supporting construction**

The supporting construction was comprised of a 3m wide x 3m high steel stud/plasterboard clad partition, built into a refractory lined steel restraint frame

The partition framing was comprised of 70mm wide galvanised steel 'C' section studs, at nominally 600mm centres, and 72mm wide galvanised steel 'U' channel head and base track, clad on both faces with 2 layers of 15mm thick 'Type F' plasterboard. 50mm thick Rockwool mineral fibre insulation (100kg/m<sup>3</sup> density) was friction fitted between the studs, but cut back for 100mm around the penetration aperture perimeters. The supporting construction was fixed on the horizontal edges only, the vertical edges remained free.

## **4 Description of specimen**

Details of the specimens are shown in Appendix 1. All measurements are in millimetres (mm) and the descriptions are written viewing the specimens from the unexposed face unless stated otherwise.

All ducts measured 1150mm long with 500mm protruding from the exposed face.

The ducts were tested uncapped at each end.

#### 4.1 Ducts fitted through partition wall (see figure 1)

Specimen Ref.	Duct material	Duct dimensions (nominal)	Duct wall thickness (nominal)	Cut out aperture dimension (nominal)
A	PVC-u	Ø100mm	1.5-1.7mm	Ø160mm
B	PVC-u	110mm wide x 54mm high	1.5-1.7mm	160mm wide x 104mm high
C	PVC-u	310mm wide x 29mm high	1.8-2.0mm	360mm wide x 79mm high
D	PVC-u	110mm wide x 54mm high	1.5-1.7mm	126mm wide x 72mm high
E	PVC-u	Ø100mm	1.5-1.7mm	Ø130mm
F	PVC-u	204mm wide x 60mm high	1.5-1.7mm	254mm wide x 110mm high
G	PVC-u	310mm wide x 29mm high	1.8-2.0mm	326mm wide x 46mm high
H	PVC-u	204mm wide x 60mm high	1.5-1.7mm	234mm wide x 84mm high
L	PVC-u	150mm wide x 70mm high	1.5-1.7mm	174mm wide x 94mm high
M	PVC-u	180mm wide x 95mm high	1.5-1.7mm	204mm wide x 116mm high

*The legal validity of this report can only be claimed on presentation of the complete report.*

## 4.2 Duct seal specifications (see figures 2-4)

Specimen Ref.	Fire sealing product	Intumescent material	Intumescent thickness
A	Tenmat Vent Duct Fire Sleeve	Tenmat Firefly 109	25mm thick x 150mm long Product ref. VDFS100
		Tenmat Firefly 107	4mm thick x 150mm long
B	Tenmat Vent Duct Fire Sleeve	Tenmat Firefly 109	25mm thick x 180mm long Product ref. VDFS110x54
C	Tenmat Vent Duct Fire Sleeve	Tenmat Firefly 109	25mm thick x 180mm long Product ref. VDFS308x29
D	Tenmat Vent Duct Wrap fitted within a Tenmat Galvanised Steel Sleeve 141mm long x 124mm wide x 70mm high Product reference VDWS110x54x141	Tenmat Firefly 107	4mm thick x 100mm long Product ref. VDW110x54
E	Tenmat Vent Duct Wrap fitted within a Tenmat Galvanised Steel Sleeve 141mm long x Ø128mm Product reference VDW100x141	Tenmat Firefly 107	8mm thick x 100mm long Product ref. VDW100
F	Tenmat Vent Duct Fire Sleeve	Tenmat Firefly 109	25mm thick x 180mm long Product ref. VDFS204x60
G	Tenmat Vent Duct Wrap fitted within a Tenmat Galvanised Steel Sleeve 141mm long x 324mm wide x 44mm high Product reference VDWS308x29x141	Tenmat Firefly 107	4mm thick x 100mm long Product ref. VDW308x29
H	Tenmat Vent Duct Wrap fitted within a Tenmat Galvanised Steel Sleeve 141mm long x 232mm wide x 82mm high Product reference VDWS204x60x141	Tenmat Firefly 107	8mm thick x 100mm long Product ref. VDW204x60
L	Tenmat Vent Duct Wrap fitted within a Tenmat Galvanised Steel Sleeve 141mm long x 172mm wide x 92mm high Product reference VDWS150x170x141	Tenmat Firefly 107	8mm thick x 100mm long Product ref. VDW150x70
M	Tenmat Vent Duct Wrap fitted within a Tenmat Galvanised Steel Sleeve 141mm long x 202mm wide x 114mm high Product reference VDWS180x90x141	Tenmat Firefly 107	8mm thick x 100mm long Product ref. VDW180x90

*The legal validity of this report can only be claimed on presentation of the complete report.*

### Mastic details

Penetrations D, E, G, H, L and M -

Nominally 5mm wide fillet of acrylic intumescent mastic sealing the steel sleeve to the wall.

Penetration A, B, C and F -

Nominally 5mm wide fillet of acrylic intumescent mastic sealing the firesleeve to the wall.

### Galvanised steel sleeves

The galvanised steel sleeves for penetrations D, G, H, L and M incorporated 2No 'L' shaped steel fixing brackets (25mm x 25mm footprint size x 0.8mm thick), spot welded 5mm from the edge of the sleeve, on the exposed side, and fixed to the supporting construction using 42mm long drywall screws. The steel sleeve for penetration E had 3No of the brackets fitted.

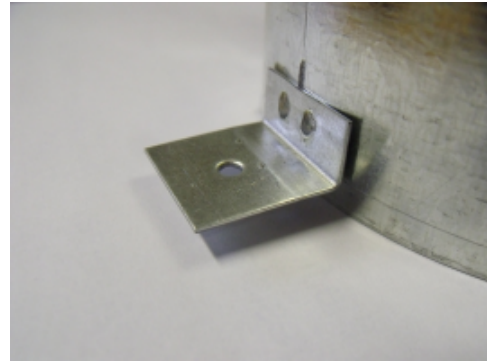
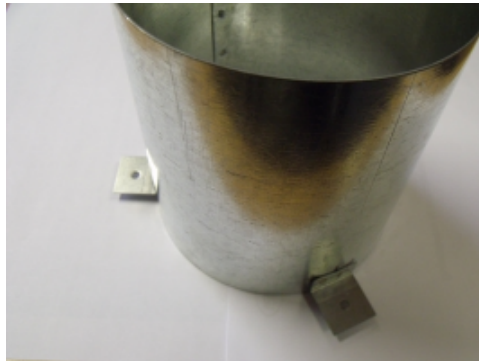

### Tenmat 109 Fire sleeves (penetrations A, B, C and F)

The Tenmat 109 fire sleeves had a longitudinal cut along the sleeve to aid in fitting. The sleeve was resealed along the cut with 50mm wide aluminium foil tape

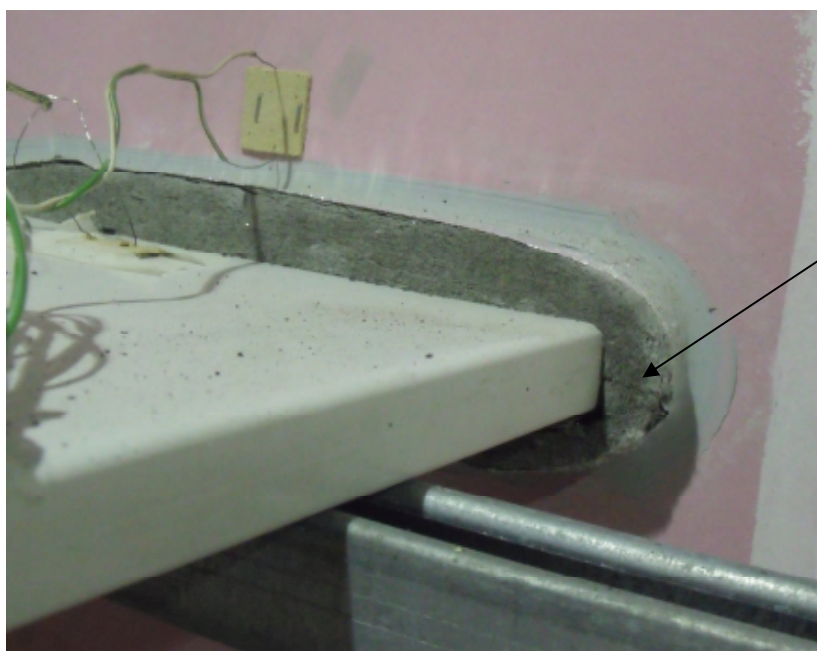

Longitudinal cut  
along length of  
fire sleeve

### 4.3 Service penetrations supports

(Read in conjunction with Figures 1 - 4 and photographs)

The service penetration support system consisted of Unistrut steel frame sections and associated attachments.

Unistrut frame section – constructed using 3mm thick profiled steel ‘U’ channel.

On the unexposed face, 2No 3000mm long lengths of Unistrut frame section were used as vertical supports on the wall/partition (see photographs). The vertical supports were bolted to the restraint frame using Unistrut steel brackets and masonry anchors. 6No 500mm long Unistrut cantilever arm sections provided horizontal supports for 6No 3000mm horizontal lengths of Unistrut, supporting the ducts at 150mm and 450mm from the walls. All ducts were cable tied down to the supports at 450mm from the wall.

On the exposed face, 2No 3000mm were used as vertical supports on the partition. 6No 500mm long Unistrut cantilever arm sections provided support for 6No 3000mm horizontal lengths of Unistrut, supporting the ducts at 150mm and 450mm from the wall.

#### Unexposed face support system

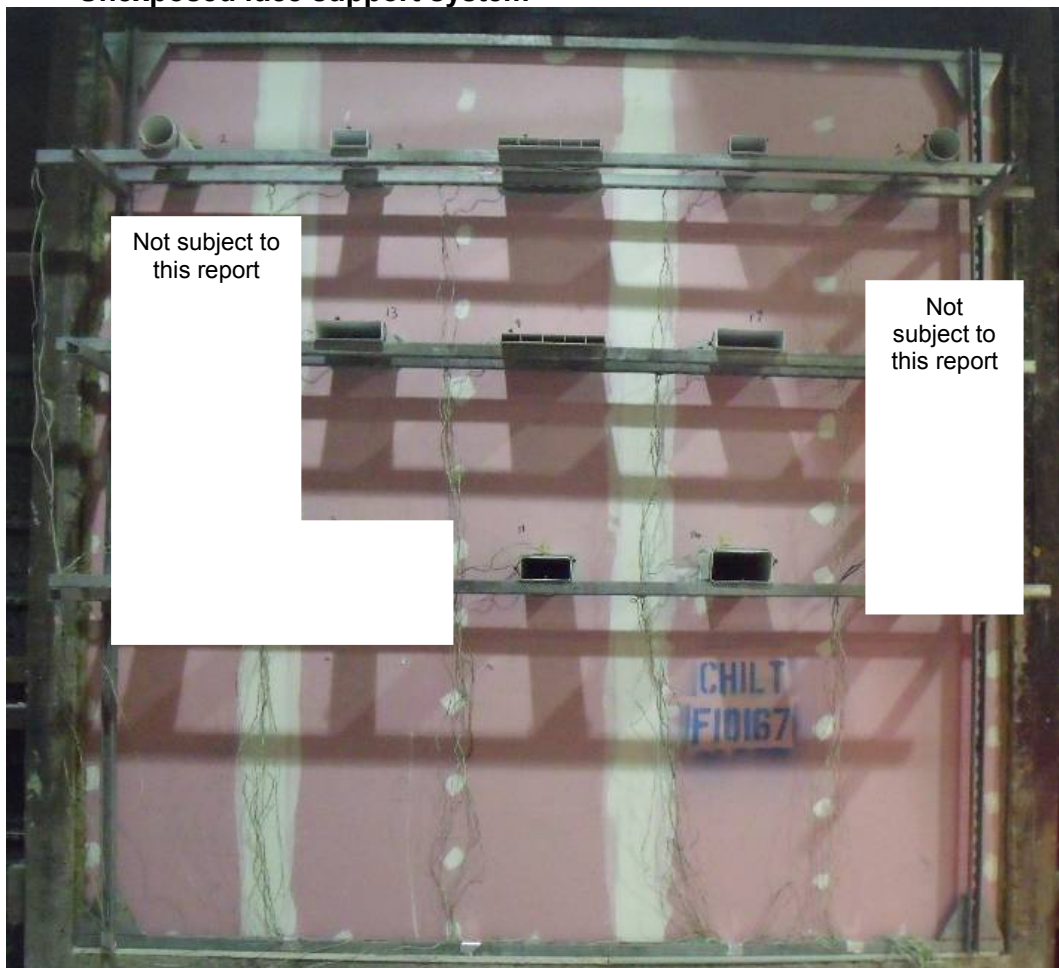

*The legal validity of this report can only be claimed on presentation of the complete report.*

Unexposed face – Duct E support system and Tenmat steel sleeve with Tenmat vent duct wrap

Tenmat galvanised steel sleeve

Tenmat Firefly 107 vent duct wrap

Acrylic intumescent mastic sealant between steel sleeve and wall



Unexposed face – Duct A support system and Tenmat vent duct sleeve

Tenmat Firefly 109 vent duct sleeve

(Tenmat Firefly 107 is not visible but is fitted between the Firefly 109 sleeve and the duct)

Acrylic intumescent mastic sealant between sleeve and wall

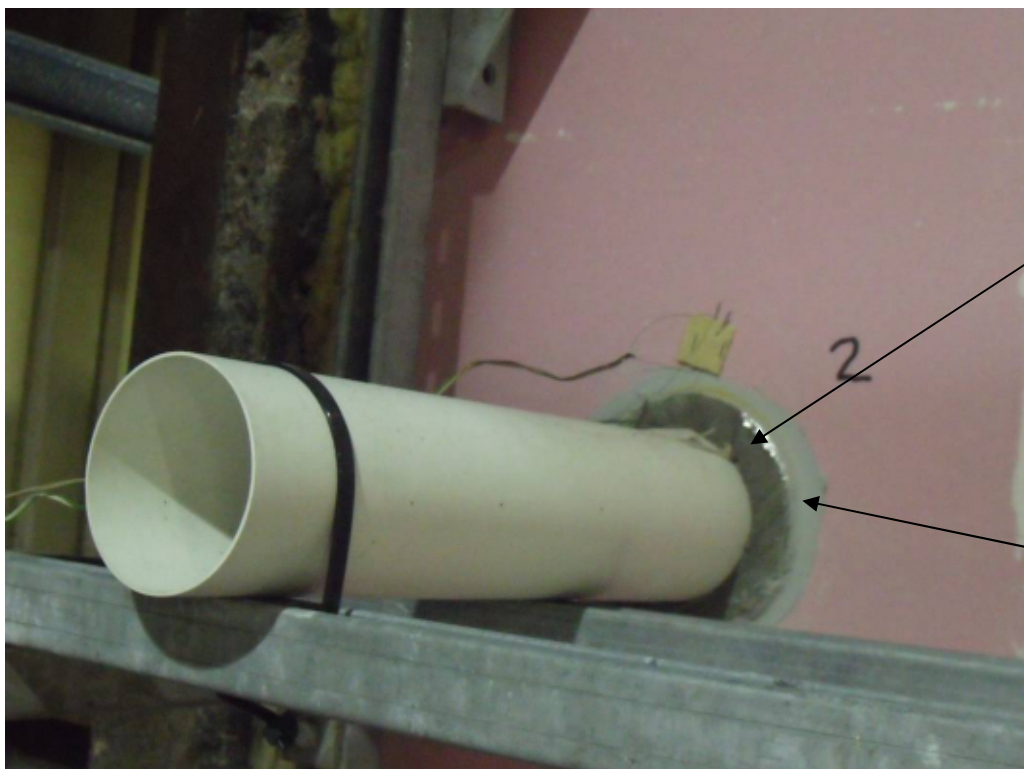

*The legal validity of this report can only be claimed on presentation of the complete report.*



## 5 Test conditions

### 5.1 Furnace temperature

The furnace was controlled to follow the temperature/time relationship specified in BSEN 1363-1: 1999 as closely as possible, using the average of nine plate thermocouples suitably distributed within the furnace. The temperatures recorded have been tabulated in Appendix 2 and are shown graphically below:

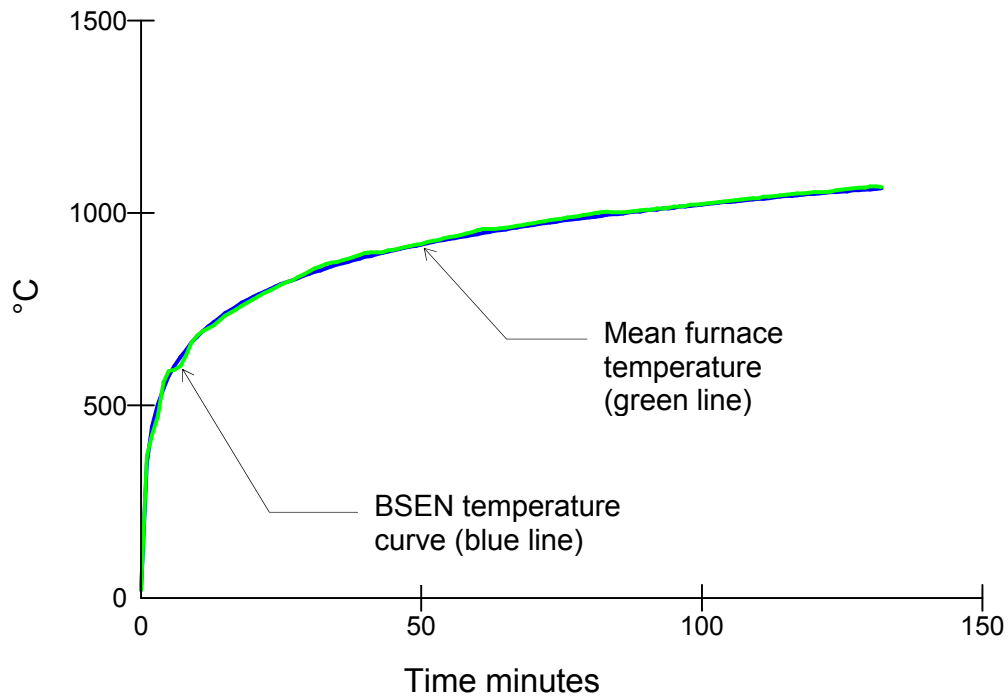

*The legal validity of this report can only be claimed on presentation of the complete report.*

## 5.2 Pressure readings

After the first 5 minutes of the test, the furnace pressure was maintained at  $7.25 \pm 5$  Pa and after 10 minutes was maintained at  $7.25 \pm 3$  Pa with respect to atmosphere, at a point 0.5m from the notional floor level. Therefore equating to 13.2 Pa at the base of ducts L and M. The pressure readings have been tabulated in Appendix 2 and are shown graphically below:

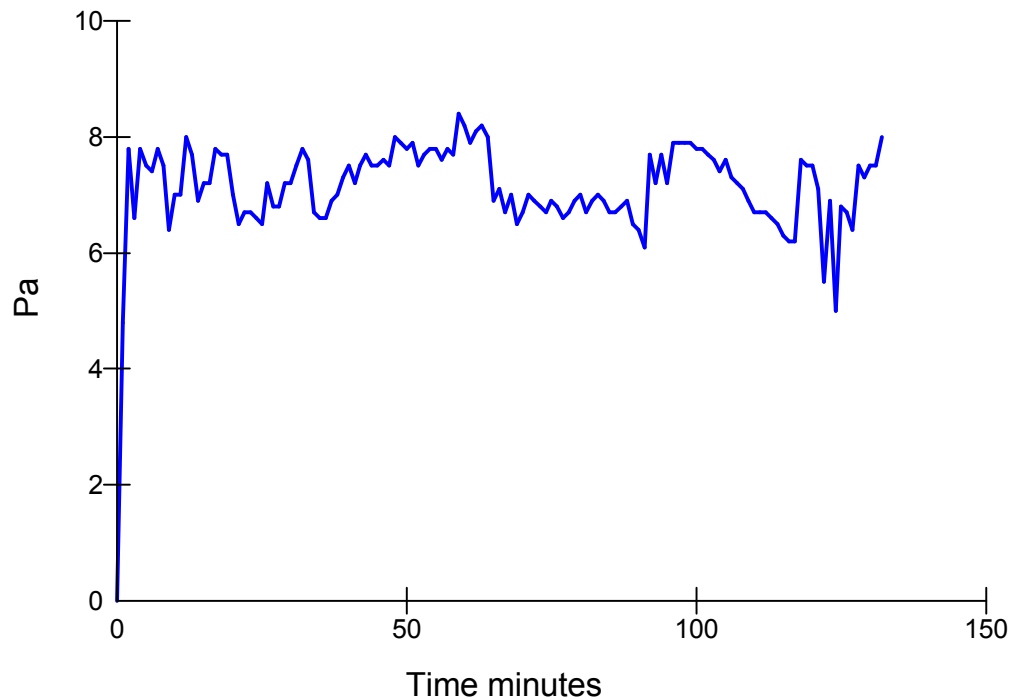

## 5.3 Ambient temperature

The ambient temperature of the test area at commencement of test was  $15^{\circ}$  C. The temperatures recorded have been tabulated in Appendix 2.

## 5.4 Thermocouple positions

The temperature of the unexposed face was monitored by means of the following thermocouples.

Graphs of each service penetration can be found in Section 10.

The temperatures recorded have been tabulated in the Appendix 2.

Duct penetration	Thermocouple number	Type (location)
-	1	Furnace
-	2	Furnace
-	3	Furnace
-	4	Furnace
-	5	Furnace
-	6	Furnace
A	10	On plasterboard 25mm from duct sleeve
A	11	On duct 25mm from plasterboard
B	12	On plasterboard 25mm from duct sleeve
B	13	On duct 25mm from plasterboard
C	14	On plasterboard 25mm from duct sleeve
C	15	On duct 25mm from plasterboard
D	16	On plasterboard 25mm from duct sleeve
D	17	On duct 25mm from plasterboard
E	18	On plasterboard 25mm from duct sleeve
E	19	On duct 25mm from plasterboard
F	20	On plasterboard 25mm from duct sleeve
F	21	On duct 25mm from plasterboard
G	22	On plasterboard 25mm from duct sleeve
G	23	On duct 25mm from plasterboard
H	24	On plasterboard 25mm from duct sleeve
H	25	On duct 25mm from plasterboard
L	32	On plasterboard 25mm from duct sleeve
L	33	On duct 25mm from plasterboard
M	34	On plasterboard 25mm from duct sleeve
M	35	On duct 25mm from plasterboard
-	38	Laboratory ambient

## 6 Observations

All comments relate to the unexposed face unless otherwise specified, (reference to Appendix 1 - figure 1).

Time (minutes)	Duct	Comments
00.00	-	Test started
00.20	All	There is smoke issuing from all duct perimeters.
00.40	A-G	The ducts have started to distort out of shape as the sleeves start to react.
02.40	M	The intumescent has reacted and sealed off the duct.
10.00	A-G	There is a decrease in the level of smoke issuing from all duct perimeters.
20.00	H, L and M	All the ducts have collapsed and fully sealed.
20.02	A-G	All ducts have collapsed and fully sealed.
30.30	L	There is smoke issuing from the duct perimeter.
40.50	H, L and M	There is smoke issuing from all ducts.
40.51	A-G	There is a decrease in the level of smoke issuing from all ducts.
78.02	A-G	There is an increase in the level of smoke issuing from all duct perimeters. All ducts have melted at the end nearest the wall of the supporting construction.
81.33	A	The intumescent collar has been forced out and is visible.
89.17	A-G	There is discolouration of the plasterboard above the ducts.
99.09	D&G	The ducts are detaching themselves from the construction wall.
100.40	L&H	The ducts are no longer in contact with the wall but the aperture is still sealed.
107.35	A	There is a glow visible at the head of the aperture where a small section of the intumescent has fallen away.
110.02	M	There is a glow visible at the top of the aperture.
119.20	M	A cotton pad integrity test was performed on the glow, no failure.
120.00	L	There is a glow visible at the top of the aperture.

*The legal validity of this report can only be claimed on presentation of the complete report.*

121.05	A	A cotton pad integrity test was performed at the head of the aperture, no failure.
121.50	L	There is continuous flaming from the specimen thereby constituting <b>integrity failure</b> .
122.20	M	A cotton pad integrity test was performed at the glow visible, no failure.
123.25	M	A cotton pad integrity test was performed at the glow visible which resulted in ignition of the cotton pad thereby constituting <b>integrity failure</b> .
126.35	A	A cotton pad integrity test was performed at the glow visible, no failure.
	D	There is a glow visible at the top of the aperture of the specimen.
128.50	A	A cotton pad integrity test was performed at the head of the aperture which resulted in ignition of the cotton pad thereby constituting <b>integrity failure</b> .
132.50		Test terminated.

## 7 Expression of results

Duct penetration seal	Integrity		Insulation
	Cotton pad	Continuous flaming	
A	128 (one hundred and twenty eight) minutes	*128 (one hundred and twenty eight) minutes	*128 (one hundred and twenty eight) minutes
B	**132 (one hundred and thirty two) minutes	**132 (one hundred and thirty two) minutes	**132 (one hundred and thirty two) minutes
C	**132 (one hundred and thirty two) minutes	**132 (one hundred and thirty two) minutes	**132 (one hundred and thirty two) minutes
D	**132 (one hundred and thirty two) minutes	**132 (one hundred and thirty two) minutes	129 (one hundred and twenty nine) minutes
E	**132 (one hundred and thirty two) minutes	**132 (one hundred and thirty two) minutes	**132 (one hundred and thirty two) minutes
F	**132 (one hundred and thirty two) minutes	**132 (one hundred and thirty two) minutes	**132 (one hundred and thirty two) minutes
G	**132 (one hundred and thirty two) minutes	**132 (one hundred and thirty two) minutes	**132 (one hundred and thirty two) minutes
H	**132 (one hundred and thirty two) minutes	**132 (one hundred and thirty two) minutes	**132 (one hundred and thirty two) minutes
L	*121 (one hundred and twenty one) minutes	121 (one hundred and twenty one) minutes	*121 (one hundred and twenty one) minutes
M	123 (one hundred and twenty three) minutes	*123 (one hundred and twenty three) minutes	120 (one hundred and twenty) minutes

\* Failure criteria was not achieved prior to initial failure

\*\* Failure criteria was not achieved prior to test termination at 132 minutes

## 8 Limitations

The results only relate to the behaviour of the element of construction under the particular conditions of test; they are not intended to be the sole criteria for assessing the potential fire performance of the element in use nor do they reflect the actual behaviour in fires.

The specification and interpretation of fire test methods are the subject of ongoing development and refinement. Changes in associated legislation may also occur. For these reasons it is recommended that the relevance of test reports over 5 years old should be considered by the user. CIFL will be able to offer, on behalf of the legal owner, a review of the procedures adopted for a particular test to ensure that they are consistent with current practices, and if required may endorse the test report.

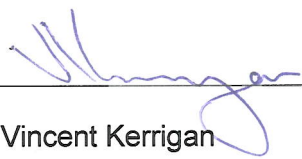
<b>Signature:</b>		
<b>Name:</b>	Robert Axe	Vincent Kerrigan
<b>Title:</b>	Deputy Head of Section – Fire Resistance	Technical Manager
<b>Date of issue:</b>	22/2/11	22-02-2011

*The legal validity of this report can only be claimed on presentation of the complete report.*

## 9 Photograph

Unexposed face at start of test

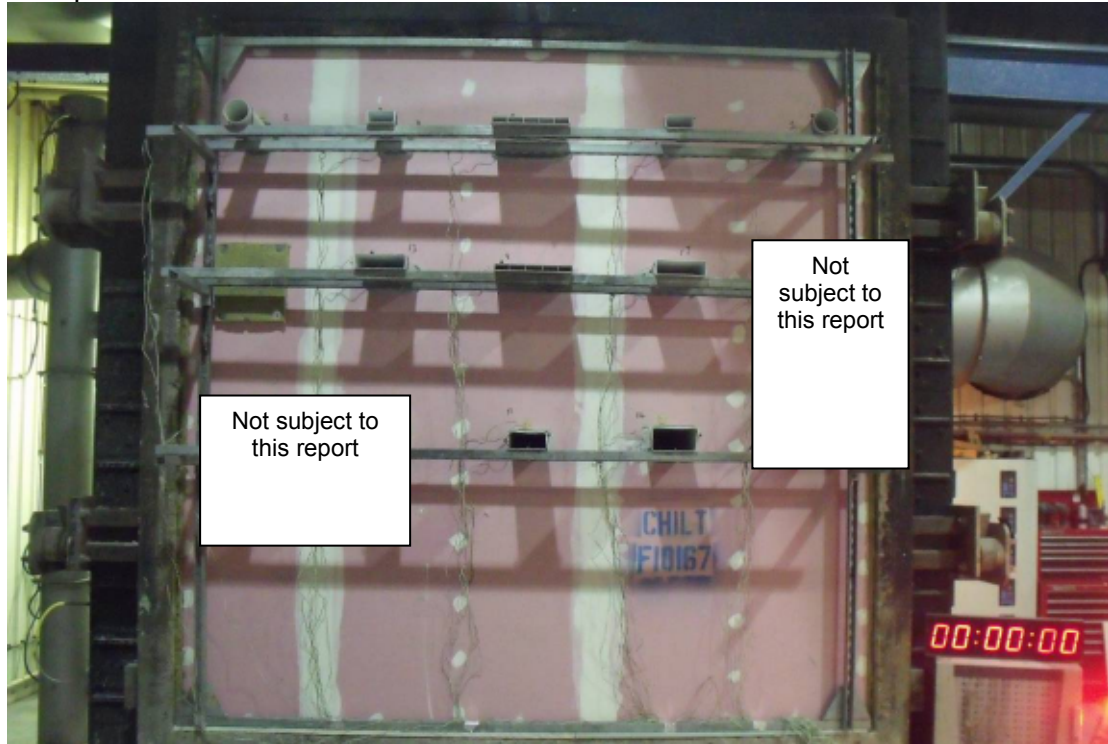

After 32 minutes



*The legal validity of this report can only be claimed on presentation of the complete report.*



After 60 minutes

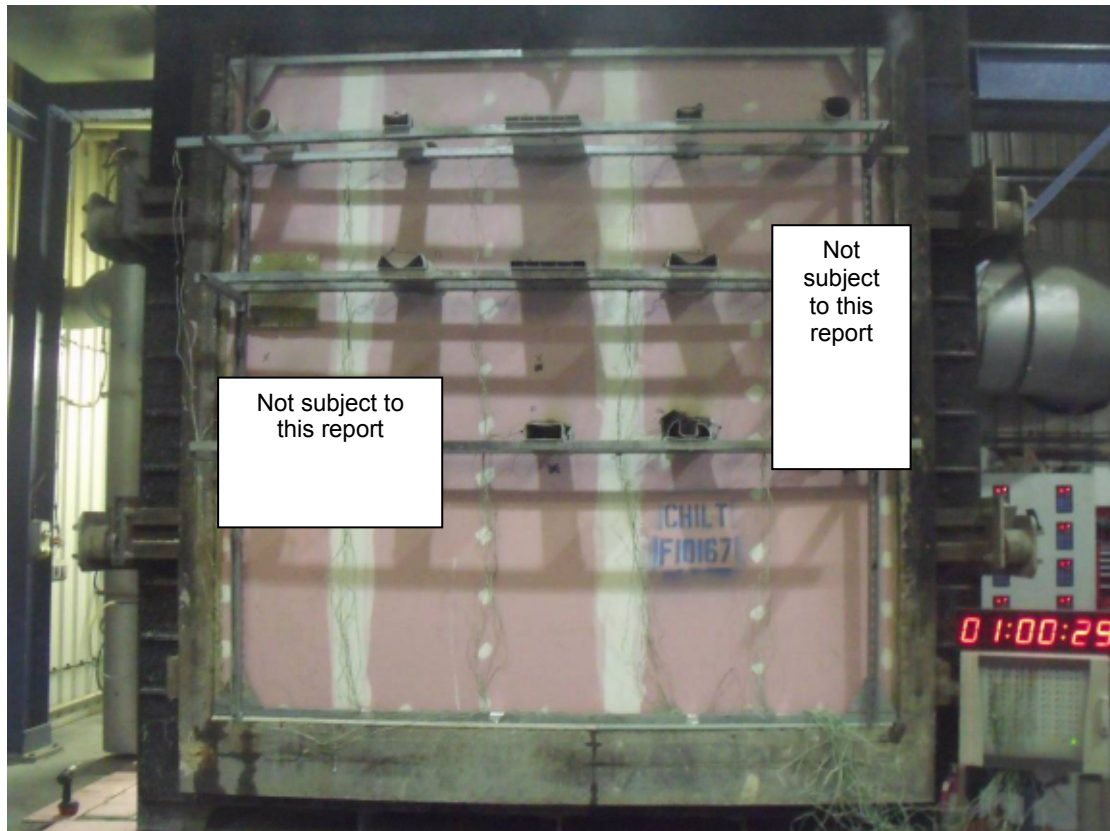

After 90 minutes

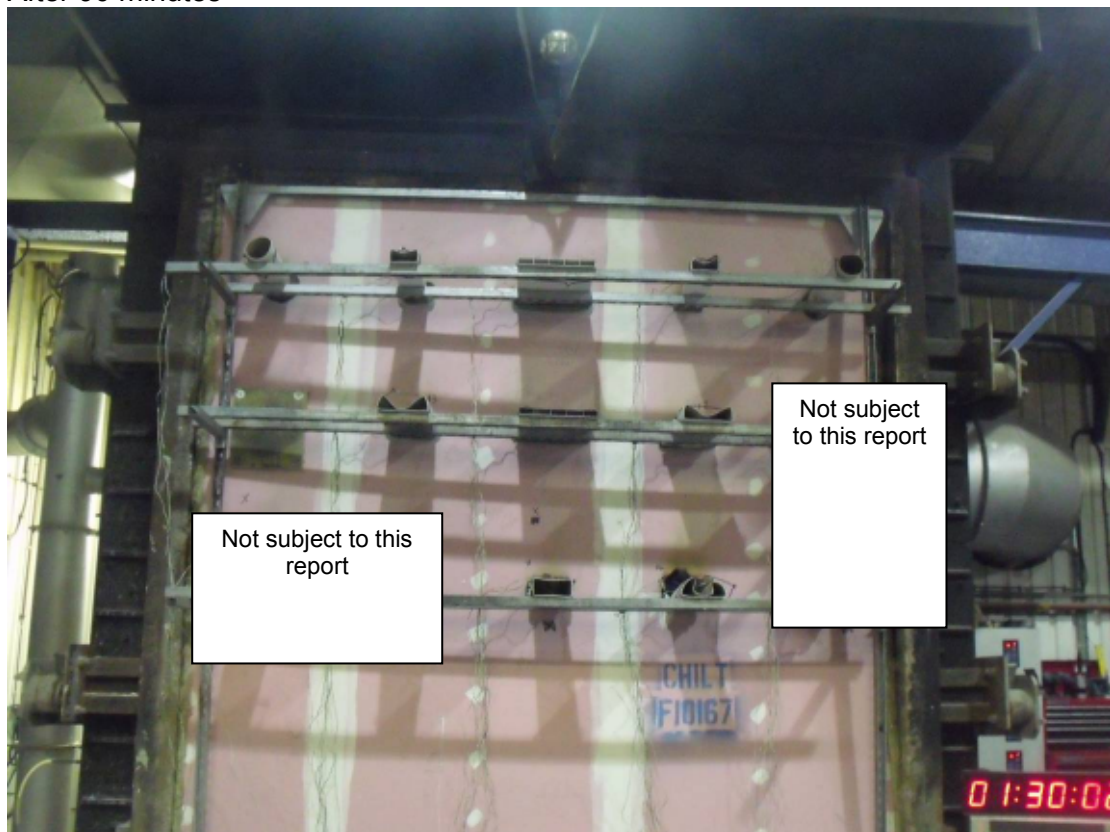

*The legal validity of this report can only be claimed on presentation of the complete report.*

After 132 minutes



*The legal validity of this report can only be claimed on presentation of the complete report.*

## 10 Graphs

### Unexposed face temperatures

#### Duct A

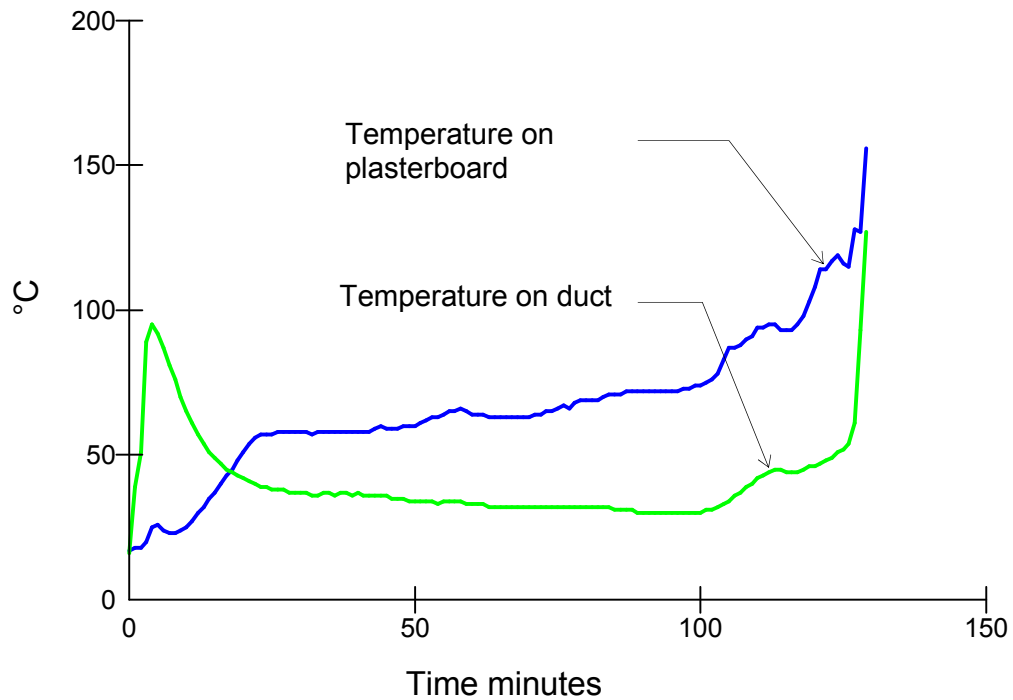

#### Duct B

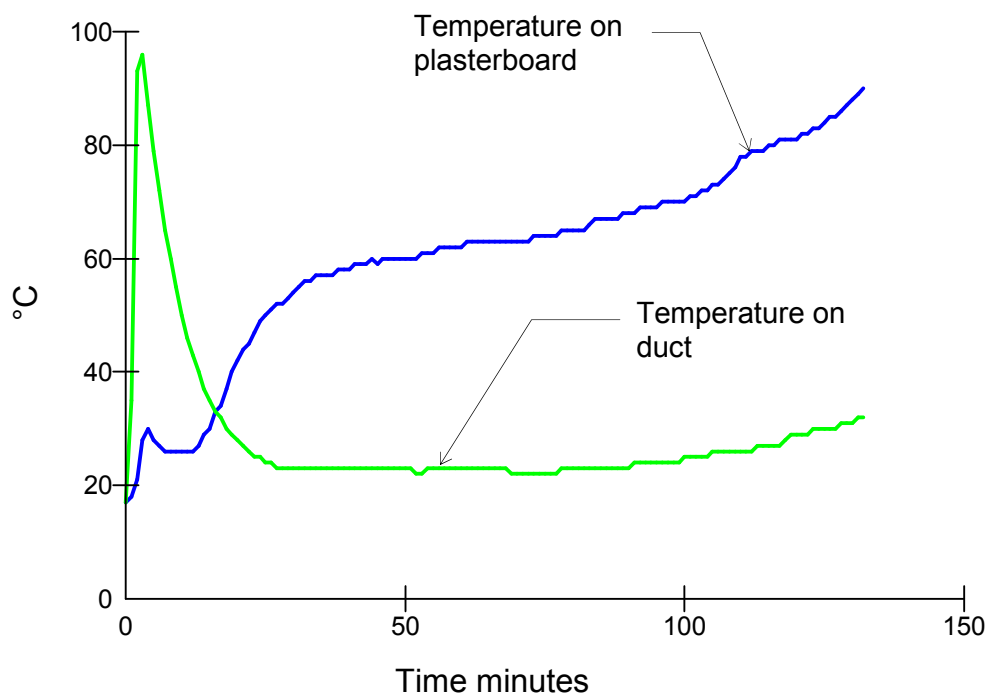

*The legal validity of this report can only be claimed on presentation of the complete report.*

### Duct C

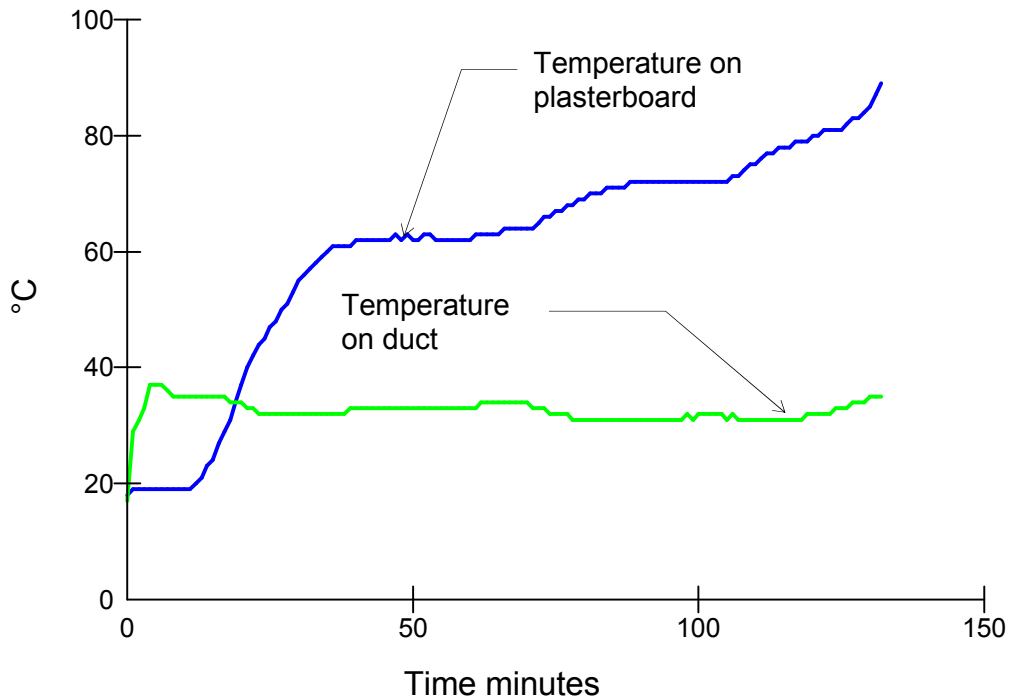

### Duct D

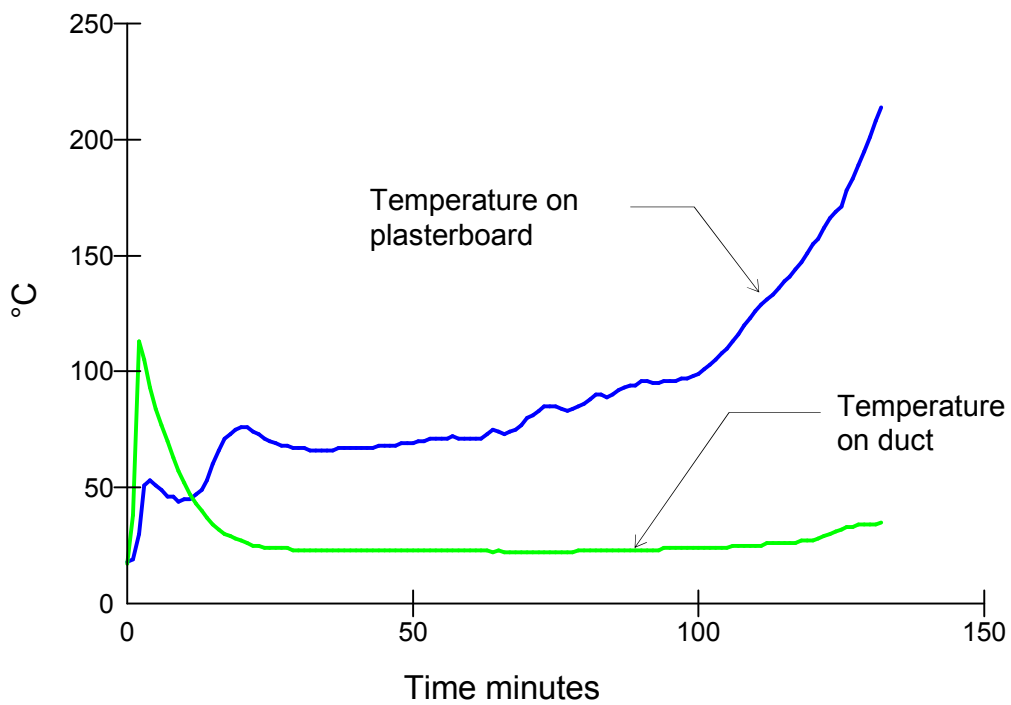

*The legal validity of this report can only be claimed on presentation of the complete report.*

### Duct E

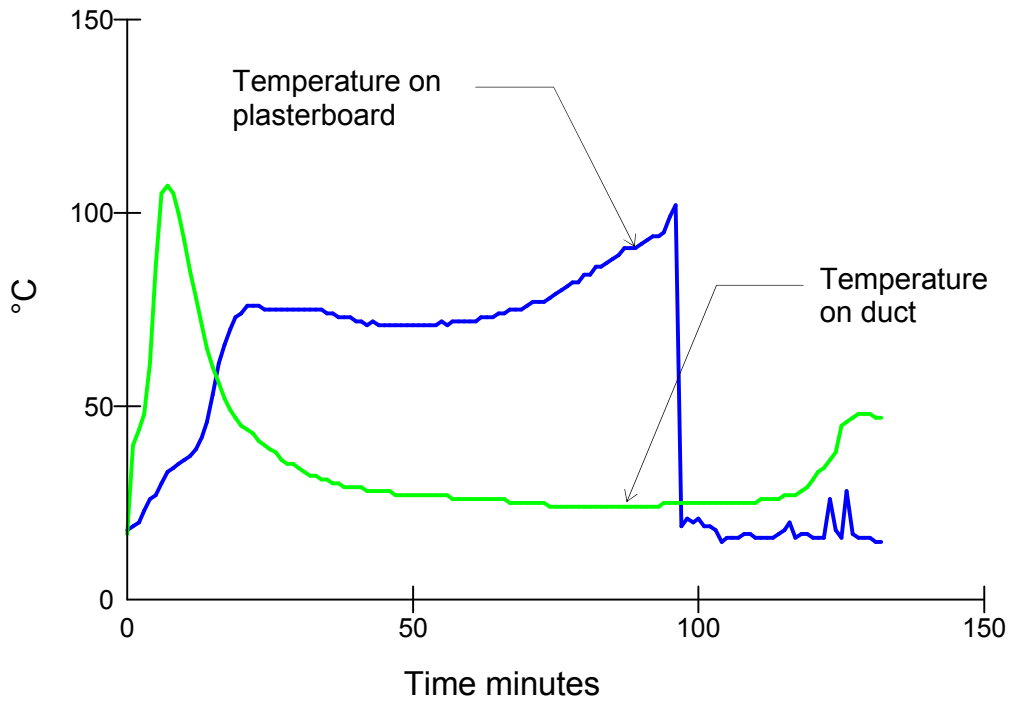

### Duct F

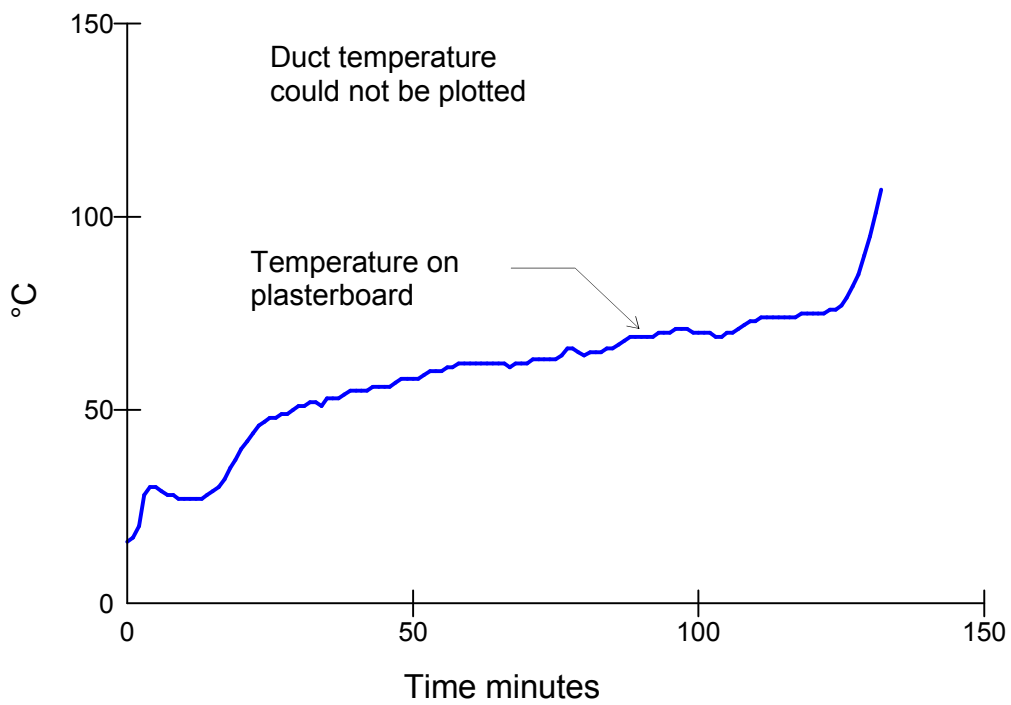

*The legal validity of this report can only be claimed on presentation of the complete report.*

### Duct G

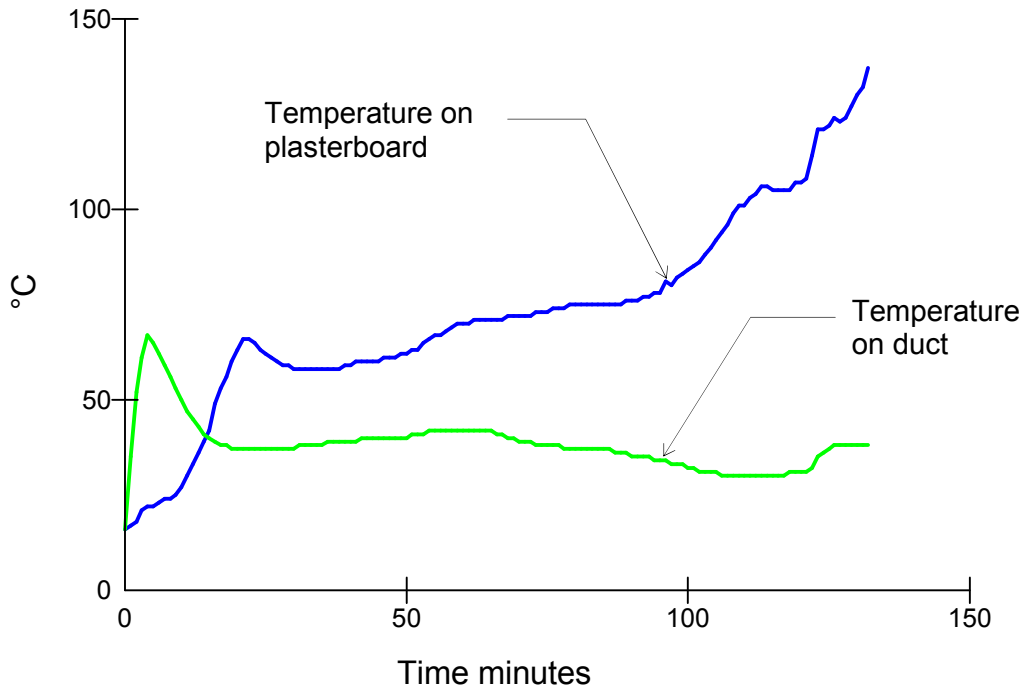

### Duct H

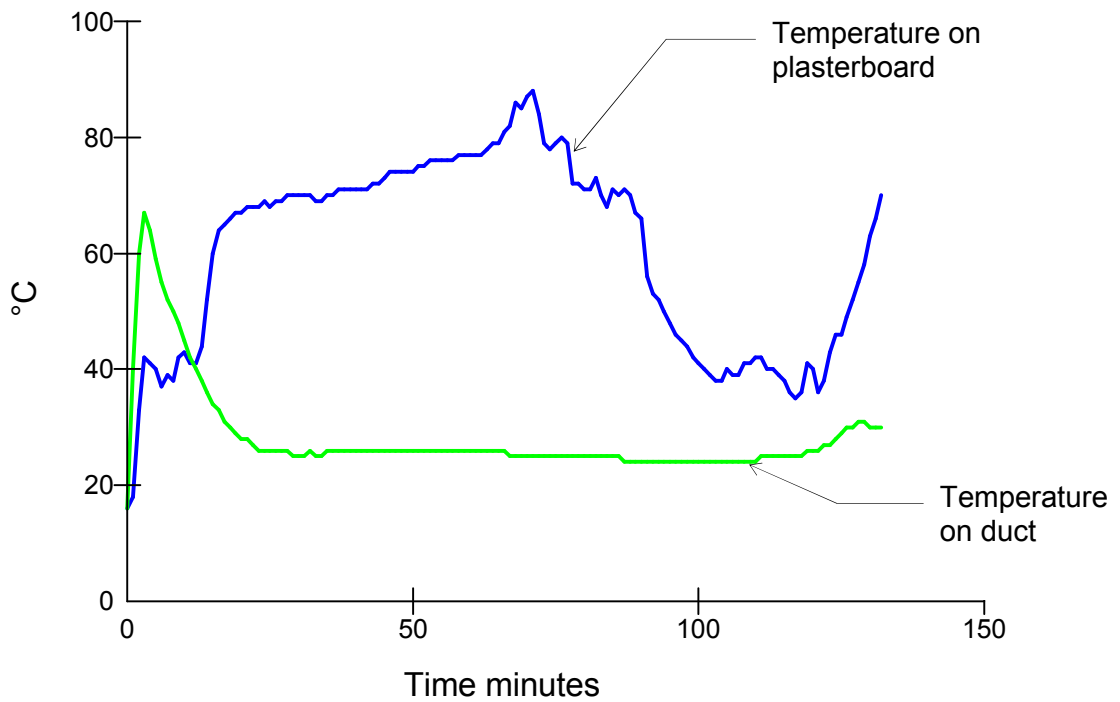

*The legal validity of this report can only be claimed on presentation of the complete report.*

### Duct L

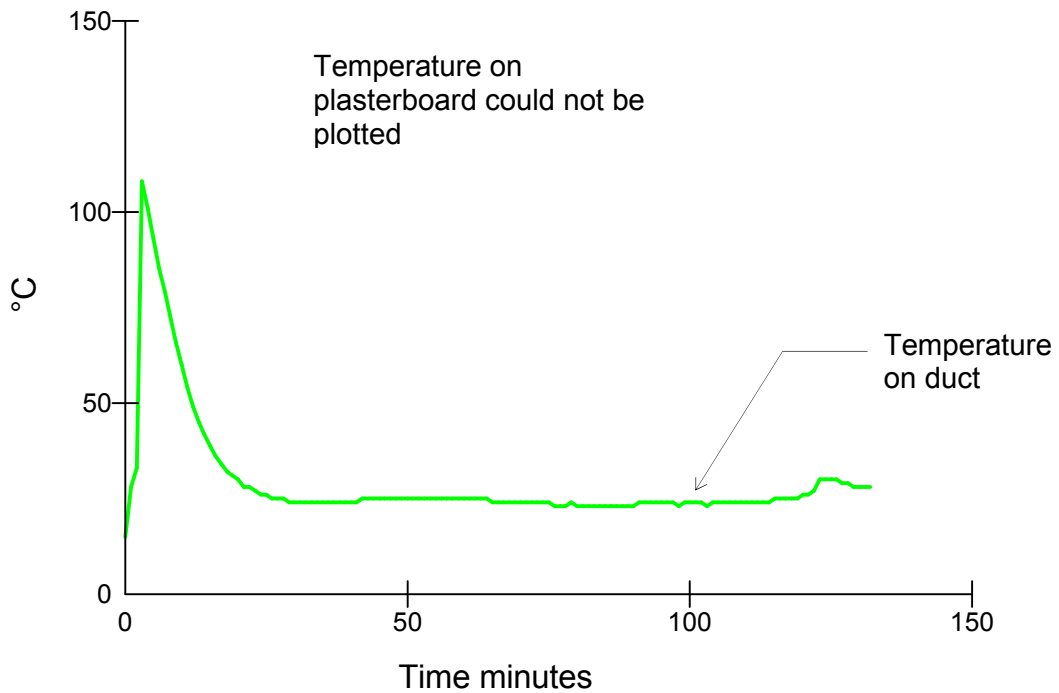

### Duct M

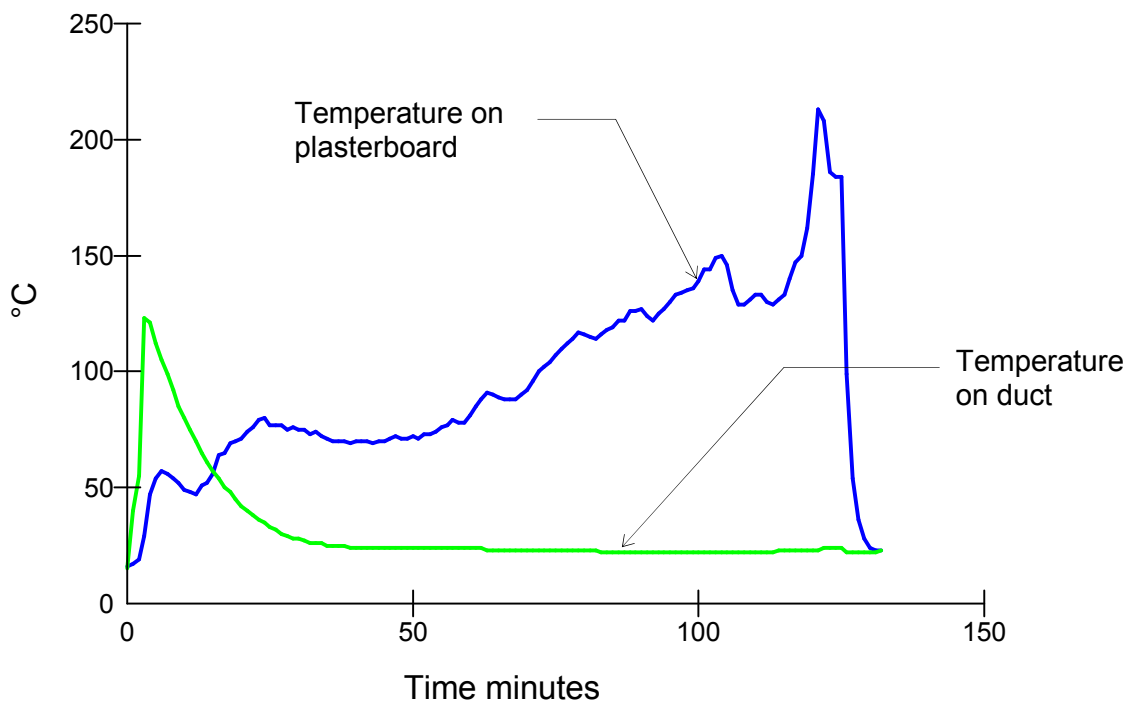

*The legal validity of this report can only be claimed on presentation of the complete report.*



## Appendix 1 – figures 1 – 5

---

*The legal validity of this report can only be claimed on presentation of the complete report.*



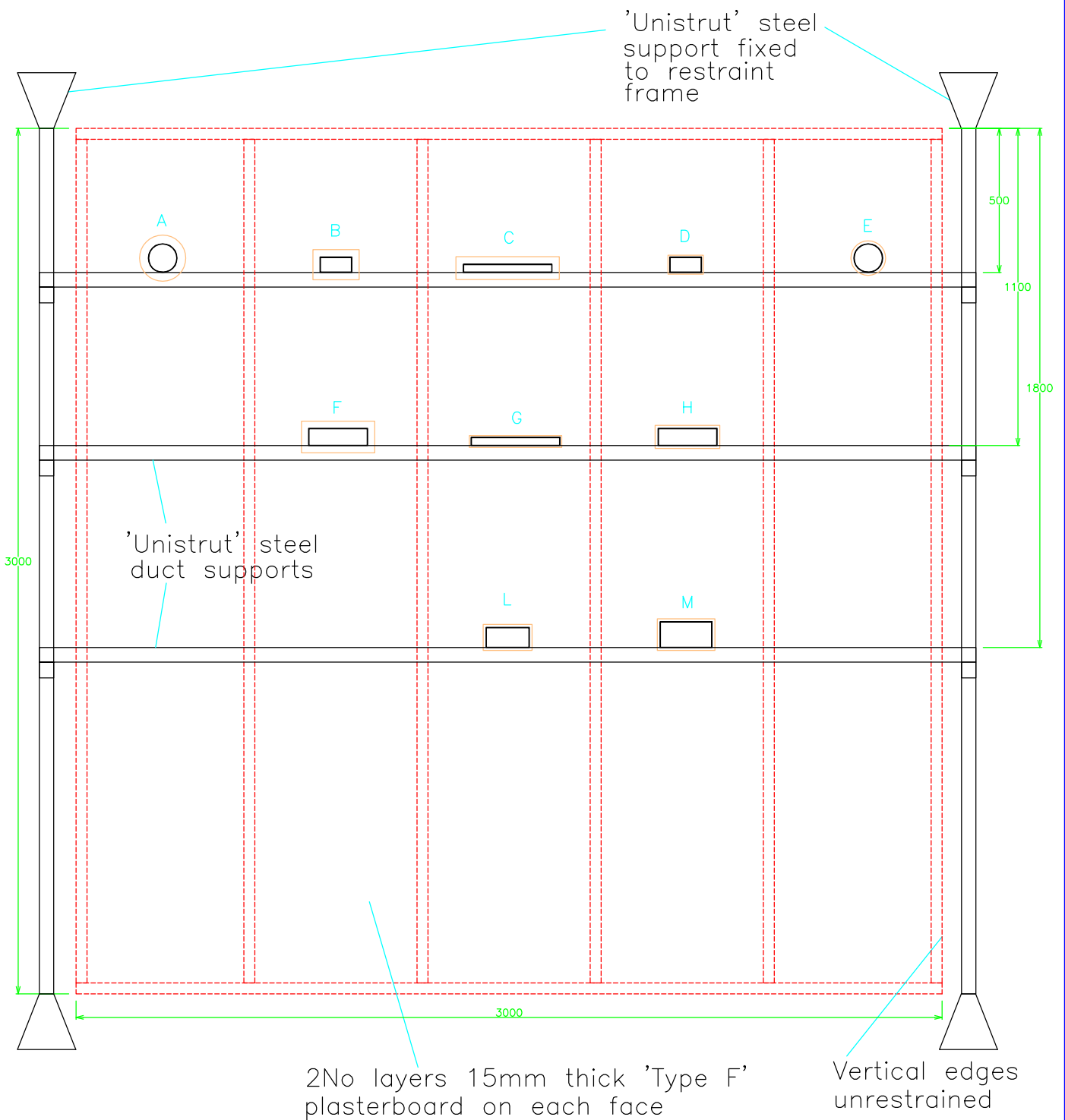

Chiltern House, Stocking Lane, Hughenden Valley  
 High Wycombe, Buckinghamshire, HP14 4ND, UK.  
 Tel: +44 (0)1494 569800 Fax: +44 (0)1494 564895

Title  
 Unexposed face front elevation  
 showing studwork and duct supports  
 (All dimensions in mm)

Date Drawn 19/01/11	Drawn By ARD	Scale NTS
Project No. Chilt/RF10167		Appendix 1

Duct sealing sealing system A

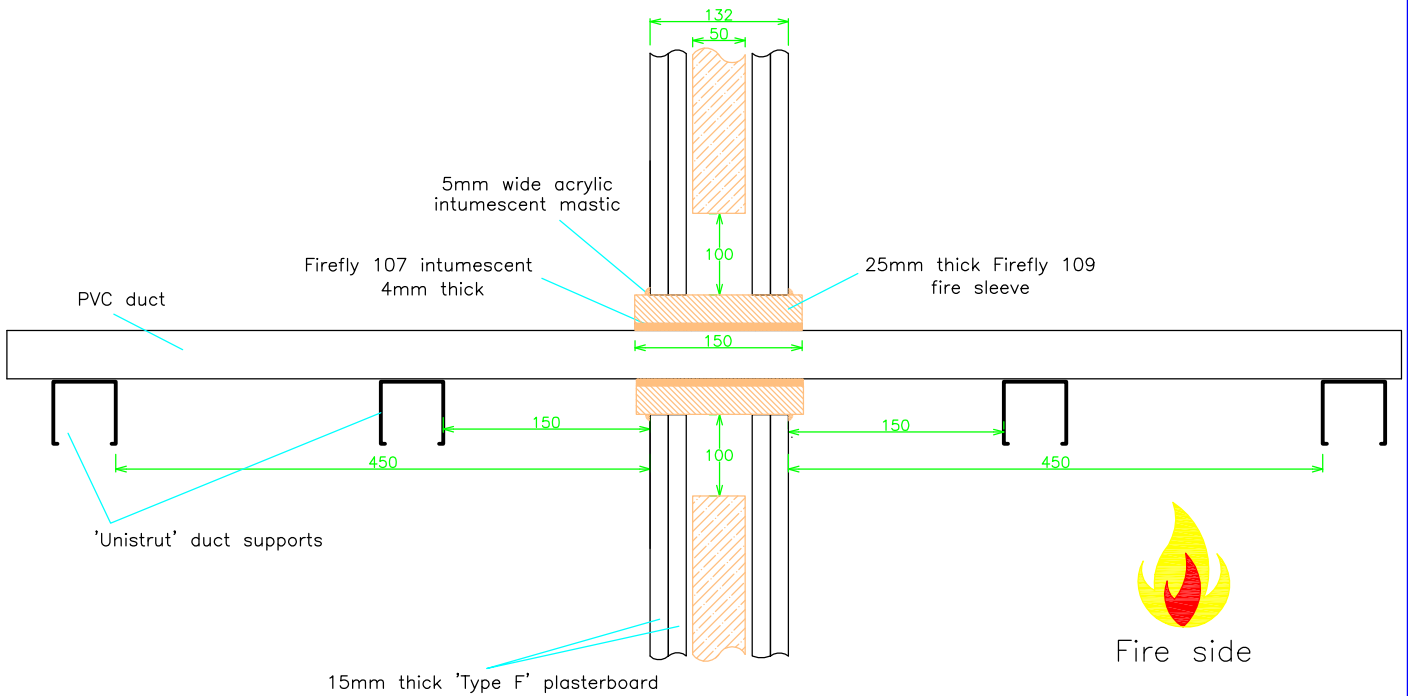

Chiltern House, Stocking Lane, Hughenden Valley  
 High Wycombe, Buckinghamshire, HP14 4ND, UK.  
 Tel: +44 (0)1494 569800 Fax: +44 (0)1494 564895

Title		
Cross section of duct seal A		
Date Drawn	Drawn By	Scale
19/01/11	ARD	NTS
Project No.		Appendix 1
Chilt/RF10167		

Duct sealing systems B,C and F

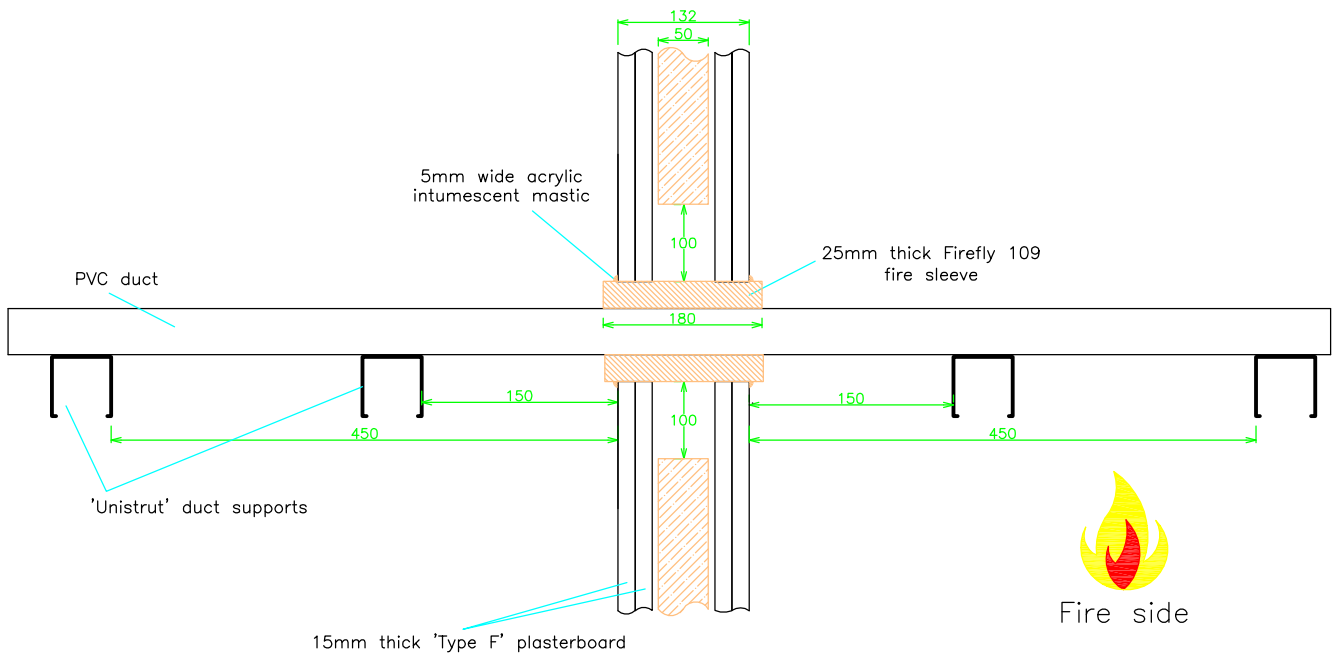

Chiltern House, Stocking Lane, Hughenden Valley  
 High Wycombe, Buckinghamshire, HP14 4ND, UK.  
 Tel: +44 (0)1494 569800 Fax: +44 (0)1494 564895

Title

Cross section of duct seals  
 B, C and F

Date Drawn

19/01/11

Drawn By

ARD

Scale

NTS

Project No.

Chilt/RF10167

Appendix 1

Duct sealing systems D, E, G, H, L and M

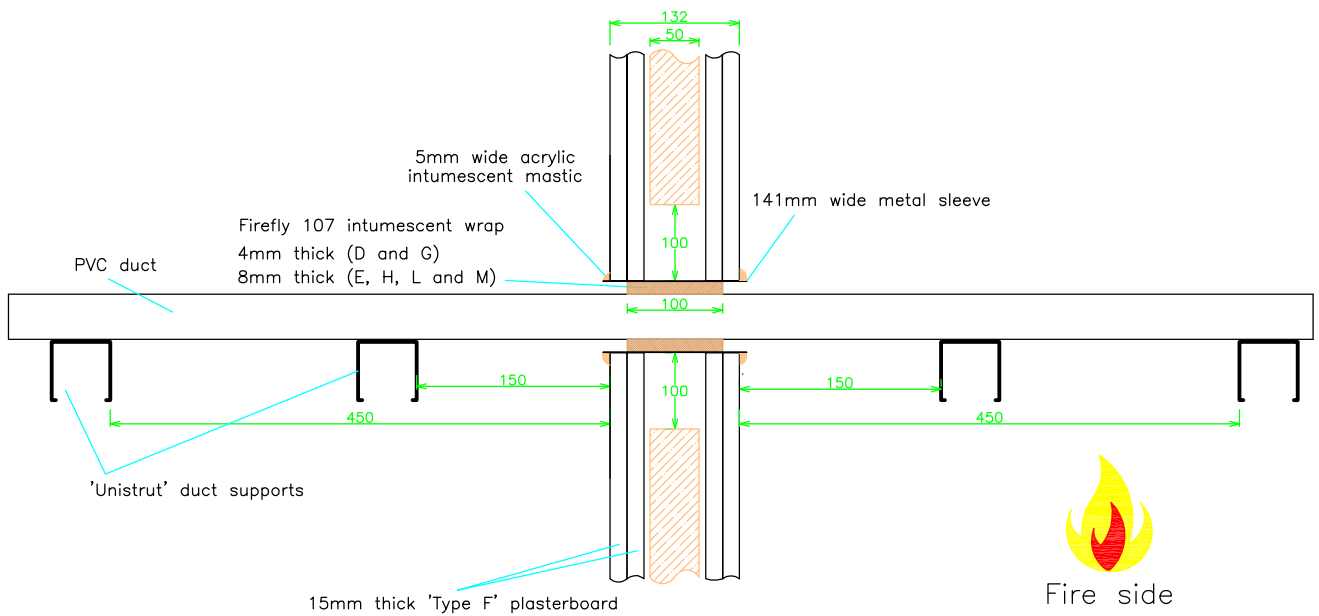

Chiltern House, Stocking Lane, Hughenden Valley  
 High Wycombe, Buckinghamshire, HP14 4ND, UK.  
 Tel: +44 (0)1494 569800 Fax: +44 (0)1494 564895

Title

Cross section of duct seals  
 D, E, G, H, I and M

Date Drawn

19/01/11

Drawn By

ARD

Scale

NTS

Project No.

Chilt/RF10167

Appendix 1

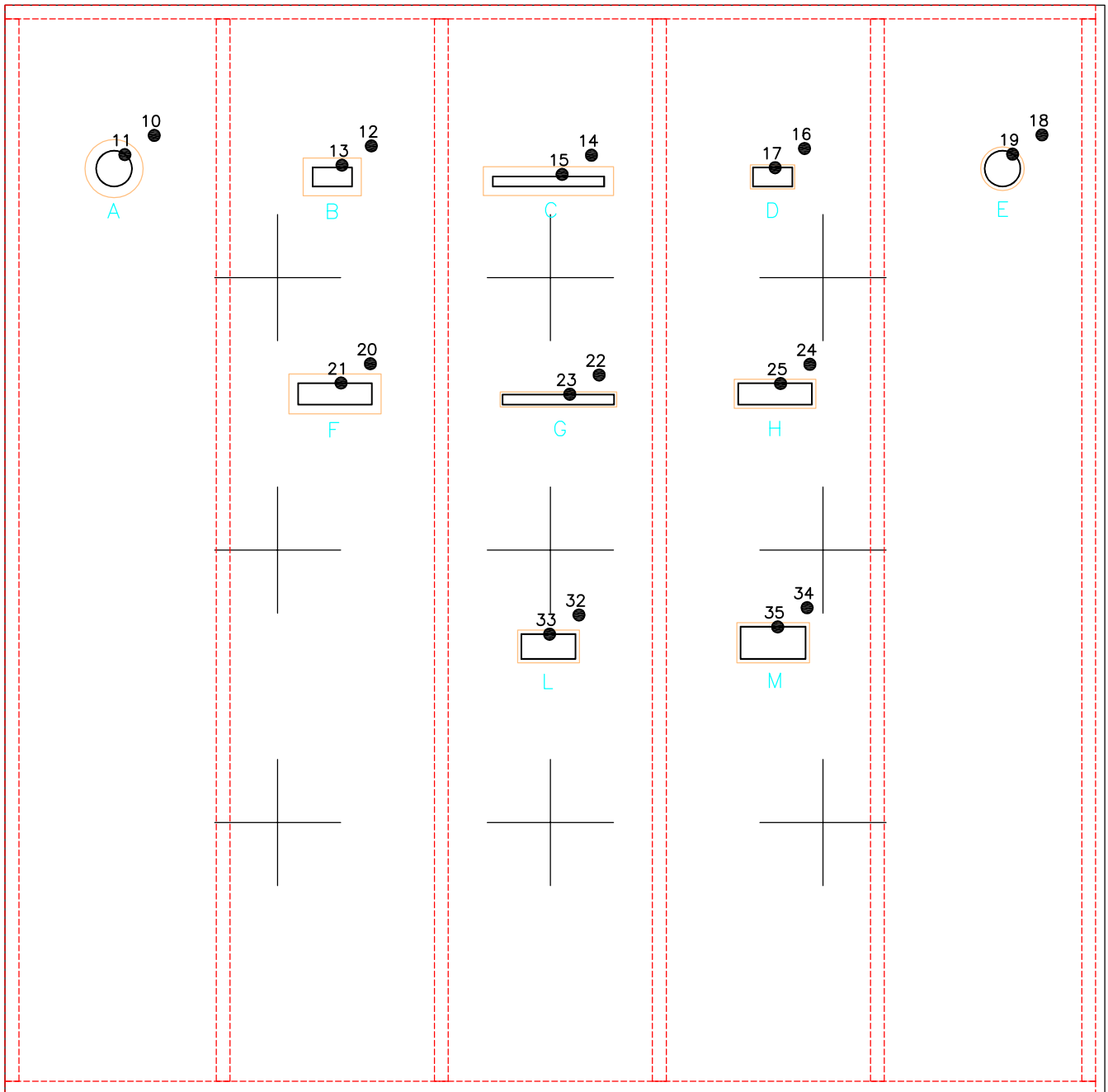

 : Furnace Thermocouples  
 : Unexposed Face Thermocouples

Viewed From Unexposed Face



Chiltern House, Stocking Lane, Hughenden Valley  
 High Wycombe, Buckinghamshire, HP14 4ND, UK.  
 Tel: +44 (0)1494 569800 Fax: +44 (0)1494 564895

Title

Thermocouple positions  
 (All dimensions in mm)

Date Drawn

19/01/11

Drawn By

ARD

Scale

NTS

Project No.

Chilt/RF10167

Appendix 1



## Appendix 2 - raw test data (12 pages)

(See figure 5 of appendix 1 for channel locations.)

Time	Chan 0	Chan 1	Chan 2	Chan 3	Chan 4	Chan 5	Chan 6	Chan 7	Chan 8	Chan 9	Chan 10	Chan 11	Chan 12	Chan 13	Chan 14	Chan 15	Chan 16	Chan 17	Chan 18
min	Pa	°C	°C	°C	°C	°C	°C	°C	°C	°C	°C	°C	°C	°C	°C	°C	°C	°C	°C
0	0	15	16	15	16	16	16	17	17	17	17	16	17	17	18	17	18	17	18
1	4.8	312	310	293	378	361	358	386	451	472	18	39	18	35	19	29	19	38	19
2	7.8	356	328	429	432	404	436	478	451	493	18	51	21	93	19	31	30	113	20
3	6.6	403	354	488	472	465	482	525	505	548	20	89	28	96	19	33	51	105	23
4	7.8	476	465	583	566	566	565	588	597	642	25	95	30	87	19	37	53	93	26
5	7.5	508	507	619	596	598	595	611	617	658	26	92	28	79	19	37	51	84	27
6	7.4	515	515	620	600	602	603	619	615	649	24	87	27	72	19	37	49	77	30
7	7.8	529	532	619	613	613	611	632	627	649	23	81	26	65	19	36	46	70	33
8	7.5	563	569	640	641	641	635	653	659	670	23	76	26	60	19	35	46	63	34
9	6.4	596	610	667	676	674	666	681	698	697	24	70	26	55	19	35	44	57	35
10	7	617	634	687	700	690	683	696	711	711	25	65	26	50	19	35	45	52	36
11	7	634	649	702	706	697	696	707	723	718	27	61	26	46	19	35	45	47	37
12	8	642	663	711	716	706	703	713	727	725	30	57	26	43	20	35	47	43	39
13	7.7	651	672	718	725	714	709	719	737	733	32	54	27	40	21	35	49	40	42
14	6.9	665	688	731	740	727	723	734	752	745	35	51	29	37	23	35	53	37	46
15	7.2	678	702	740	748	736	732	742	764	758	37	49	30	35	24	35	60	34	53
16	7.2	689	711	746	756	744	743	752	772	768	40	47	33	33	27	35	66	32	61
17	7.8	700	721	755	764	752	751	761	780	773	43	45	34	32	29	35	71	30	66
18	7.7	711	730	761	767	760	759	767	789	781	45	44	37	30	31	34	73	29	70
19	7.7	721	738	771	773	766	767	776	797	791	48	43	40	29	34	34	75	28	73



Time	Chan 0	Chan 1	Chan 2	Chan 3	Chan 4	Chan 5	Chan 6	Chan 7	Chan 8	Chan 9	Chan 10	Chan 11	Chan 12	Chan 13	Chan 14	Chan 15	Chan 16	Chan 17	Chan 18
min	Pa	°C	°C	°C	°C	°C	°C	°C	°C	°C	°C	°C	°C	°C	°C	°C	°C	°C	°C
20	7	729	750	776	784	778	776	786	805	797	51	42	42	28	37	34	76	27	74
21	6.5	738	759	781	792	786	785	795	814	804	54	41	44	27	40	33	76	26	76
22	6.7	746	768	791	801	794	793	803	820	808	56	40	45	26	42	33	74	25	76
23	6.7	753	775	798	808	801	800	810	829	815	57	39	47	25	44	32	73	25	76
24	6.6	764	783	805	815	807	810	817	835	820	57	39	49	25	45	32	71	24	75
25	6.5	772	791	811	823	815	815	825	842	828	57	38	50	24	47	32	70	24	75
26	7.2	780	799	817	831	823	823	832	847	834	58	38	51	24	48	32	69	24	75
27	6.8	789	807	823	834	828	829	838	853	841	58	38	52	23	50	32	68	24	75
28	6.8	797	815	831	839	835	838	847	862	847	58	37	52	23	51	32	68	24	75
29	7.2	805	823	835	847	841	844	852	866	852	58	37	53	23	53	32	67	23	75
30	7.2	816	831	844	857	850	851	861	873	862	58	37	54	23	55	32	67	23	75
31	7.5	821	838	851	863	855	858	866	879	864	58	37	55	23	56	32	67	23	75
32	7.8	828	846	859	869	861	865	873	885	870	57	36	56	23	57	32	66	23	75
33	7.6	837	853	863	871	867	870	878	891	879	58	36	56	23	58	32	66	23	75
34	6.7	841	858	868	879	870	874	881	894	880	58	37	57	23	59	32	66	23	75
35	6.6	843	859	868	880	872	875	881	894	882	58	37	57	23	60	32	66	23	74
36	6.6	848	863	872	886	877	879	886	898	888	58	36	57	23	61	32	66	23	74
37	6.9	853	867	876	890	881	884	890	902	891	58	37	57	23	61	32	67	23	73
38	7	859	872	884	894	886	889	894	906	895	58	37	58	23	61	32	67	23	73
39	7.3	864	877	887	898	891	892	897	908	901	58	36	58	23	61	33	67	23	73
40	7.5	869	883	892	902	895	897	901	913	905	58	37	58	23	62	33	67	23	72
41	7.2	872	886	897	905	896	898	903	915	909	58	36	59	23	62	33	67	23	72
42	7.5	874	886	896	906	895	899	905	915	909	58	36	59	23	62	33	67	23	71
43	7.7	874	887	897	906	897	900	905	916	907	59	36	59	23	62	33	67	23	72



Time	Chan 0	Chan 1	Chan 2	Chan 3	Chan 4	Chan 5	Chan 6	Chan 7	Chan 8	Chan 9	Chan 10	Chan 11	Chan 12	Chan 13	Chan 14	Chan 15	Chan 16	Chan 17	Chan 18
min	Pa	°C	°C	°C	°C	°C	°C	°C	°C	°C	°C	°C	°C	°C	°C	°C	°C	°C	°C
44	7.5	880	890	899	909	900	902	908	920	913	60	36	60	23	62	33	68	23	71
45	7.5	883	893	902	912	903	906	912	922	915	59	36	59	23	62	33	68	23	71
46	7.6	884	897	904	917	907	908	915	925	920	59	35	60	23	62	33	68	23	71
47	7.5	888	900	907	918	910	912	917	928	921	59	35	60	23	63	33	68	23	71
48	8	890	904	912	924	914	916	920	931	923	60	35	60	23	62	33	69	23	71
49	7.9	894	907	914	925	917	918	923	933	925	60	34	60	23	63	33	69	23	71
50	7.8	896	910	915	929	921	922	927	938	930	60	34	60	23	62	33	69	23	71
51	7.9	899	914	919	932	925	925	930	940	932	61	34	60	23	62	33	70	23	71
52	7.5	905	917	924	936	928	928	934	943	936	62	34	60	22	63	33	70	23	71
53	7.7	906	919	925	937	930	932	937	946	939	63	34	61	22	63	33	71	23	71
54	7.8	910	923	929	942	934	936	940	950	942	63	33	61	23	62	33	71	23	71
55	7.8	914	927	930	946	938	939	942	952	945	64	34	61	23	62	33	71	23	72
56	7.6	916	930	934	948	941	942	946	956	949	65	34	62	23	62	33	71	23	71
57	7.8	918	933	936	953	944	946	950	958	952	65	34	62	23	62	33	72	23	72
58	7.7	924	937	941	954	949	948	954	962	959	66	34	62	23	62	33	71	23	72
59	8.4	928	940	945	958	951	954	956	965	960	65	33	62	23	62	33	71	23	72
60	8.2	931	945	949	963	956	957	959	967	961	64	33	62	23	62	33	71	23	72
61	7.9	937	950	953	965	960	961	963	970	968	64	33	63	23	63	33	71	23	72
62	8.1	937	950	953	966	961	962	962	969	965	64	33	63	23	63	34	71	23	73
63	8.2	937	950	953	965	960	963	963	970	966	63	32	63	23	63	34	73	23	73
64	8	937	952	954	967	961	965	964	971	967	63	32	63	23	63	34	75	22	73
65	6.9	941	954	957	969	963	966	966	973	968	63	32	63	23	63	34	74	23	74
66	7.1	943	956	958	971	965	968	968	974	971	63	32	63	23	64	34	73	22	74
67	6.7	946	959	963	973	967	971	970	977	972	63	32	63	23	64	34	74	22	75





Time	Chan 0	Chan 1	Chan 2	Chan 3	Chan 4	Chan 5	Chan 6	Chan 7	Chan 8	Chan 9	Chan 10	Chan 11	Chan 12	Chan 13	Chan 14	Chan 15	Chan 16	Chan 17	Chan 18
min	Pa	°C	°C	°C	°C	°C	°C	°C	°C	°C	°C	°C	°C	°C	°C	°C	°C	°C	°C
68	7	948	961	964	976	969	973	972	979	974	63	32	63	23	64	34	75	22	75
69	6.5	951	964	968	979	972	975	975	982	977	63	32	63	22	64	34	77	22	75
70	6.7	953	966	970	980	974	978	978	983	979	63	32	63	22	64	34	80	22	76
71	7	955	969	973	984	976	981	980	986	981	64	32	63	22	64	33	81	22	77
72	6.9	958	971	975	985	979	983	982	989	985	64	32	63	22	65	33	83	22	77
73	6.8	962	973	977	988	981	986	985	992	986	65	32	64	22	66	33	85	22	77
74	6.7	963	975	979	990	984	987	987	993	990	65	32	64	22	66	32	85	22	78
75	6.9	967	978	982	992	985	991	990	996	992	66	32	64	22	67	32	85	22	79
76	6.8	970	980	985	994	988	992	992	998	994	67	32	64	22	67	32	84	22	80
77	6.6	971	983	986	996	990	995	994	1001	995	66	32	64	22	68	32	83	22	81
78	6.7	973	985	988	999	992	997	996	1002	997	68	32	65	23	68	31	84	22	82
79	6.9	976	988	992	1002	995	1000	1000	1005	1000	69	32	65	23	69	31	85	23	82
80	7	980	990	994	1005	998	1003	1002	1006	1001	69	32	65	23	69	31	86	23	84
81	6.7	982	992	996	1007	1000	1005	1004	1010	1005	69	32	65	23	70	31	88	23	84
82	6.9	984	994	998	1007	1002	1008	1005	1011	1006	69	32	65	23	70	31	90	23	86
83	7	986	996	1000	1010	1003	1009	1008	1013	1008	70	32	66	23	70	31	90	23	86
84	6.9	984	995	997	1007	1001	1007	1005	1010	1005	71	32	67	23	71	31	89	23	87
85	6.7	985	996	1000	1007	1001	1008	1006	1011	1005	71	31	67	23	71	31	90	23	88
86	6.7	985	996	1000	1008	1002	1009	1006	1010	1006	71	31	67	23	71	31	92	23	89
87	6.8	987	998	1001	1010	1002	1010	1007	1012	1006	72	31	67	23	71	31	93	23	91
88	6.9	988	999	1002	1012	1005	1012	1010	1013	1008	72	31	67	23	72	31	94	23	91
89	6.5	990	1000	1003	1014	1005	1013	1011	1015	1011	72	30	68	23	72	31	94	23	91
90	6.4	992	1002	1005	1014	1007	1015	1013	1016	1012	72	30	68	23	72	31	96	23	92
91	6.1	993	1003	1007	1015	1009	1017	1012	1017	1014	72	30	68	24	72	31	96	23	93



Time	Chan 0	Chan 1	Chan 2	Chan 3	Chan 4	Chan 5	Chan 6	Chan 7	Chan 8	Chan 9	Chan 10	Chan 11	Chan 12	Chan 13	Chan 14	Chan 15	Chan 16	Chan 17	Chan 18
min	Pa	°C	°C	°C	°C	°C	°C	°C	°C	°C	°C	°C	°C	°C	°C	°C	°C	°C	°C
92	7.7	995	1005	1009	1017	1010	1018	1015	1019	1015	72	30	69	24	72	31	95	23	94
93	7.2	996	1006	1010	1018	1012	1020	1017	1020	1017	72	30	69	24	72	31	95	23	94
94	7.7	998	1008	1012	1019	1014	1021	1018	1022	1018	72	30	69	24	72	31	96	24	95
95	7.2	1000	1009	1014	1021	1015	1023	1019	1023	1020	72	30	69	24	72	31	96	24	99
96	7.9	1001	1011	1016	1023	1018	1023	1021	1025	1022	72	30	70	24	72	31	96	24	102
97	7.9	1003	1013	1017	1025	1019	1025	1024	1027	1024	73	30	70	24	72	31	97	24	19
98	7.9	1006	1015	1018	1027	1021	1025	1024	1028	1026	73	30	70	24	72	32	97	24	21
99	7.9	1007	1016	1020	1029	1023	1027	1026	1030	1025	74	30	70	24	72	31	98	24	20
100	7.8	1009	1017	1021	1030	1024	1028	1028	1032	1028	74	30	70	25	72	32	99	24	21
101	7.8	1011	1019	1023	1030	1026	1029	1029	1033	1030	75	31	71	25	72	32	101	24	19
102	7.7	1013	1020	1026	1033	1026	1031	1031	1035	1032	76	31	71	25	72	32	103	24	19
103	7.6	1014	1023	1027	1035	1028	1032	1032	1036	1033	78	32	72	25	72	32	105	24	18
104	7.4	1016	1024	1028	1037	1030	1036	1033	1038	1034	83	33	72	25	72	32	108	24	15
105	7.6	1018	1026	1029	1038	1032	1035	1035	1040	1036	87	34	73	26	72	31	110	24	16
106	7.3	1019	1028	1031	1039	1034	1039	1037	1042	1037	87	36	73	26	73	32	113	25	16
107	7.2	1021	1029	1032	1041	1034	1039	1039	1044	1038	88	37	74	26	73	31	116	25	16
108	7.1	1023	1031	1034	1043	1036	1041	1040	1044	1039	90	39	75	26	74	31	120	25	17
109	6.9	1024	1032	1036	1045	1038	1043	1042	1047	1041	91	40	76	26	75	31	123	25	17
110	6.7	1025	1034	1037	1046	1039	1043	1044	1047	1042	94	42	78	26	75	31	126	25	16
111	6.7	1027	1035	1039	1048	1041	1046	1046	1050	1044	94	43	78	26	76	31	129	25	16
112	6.7	1030	1036	1039	1048	1042	1048	1047	1050	1046	95	44	79	26	77	31	131	26	16
113	6.6	1030	1037	1042	1050	1044	1049	1048	1051	1048	95	45	79	27	77	31	133	26	16
114	6.5	1031	1038	1043	1051	1044	1050	1050	1053	1049	93	45	79	27	78	31	136	26	17
115	6.3	1034	1039	1044	1053	1046	1052	1052	1054	1050	93	44	80	27	78	31	139	26	18



Time	Chan 0	Chan 1	Chan 2	Chan 3	Chan 4	Chan 5	Chan 6	Chan 7	Chan 8	Chan 9	Chan 10	Chan 11	Chan 12	Chan 13	Chan 14	Chan 15	Chan 16	Chan 17	Chan 18
min	Pa	°C	°C	°C	°C	°C	°C	°C	°C	°C	°C	°C	°C	°C	°C	°C	°C	°C	°C
116	6.2	1036	1041	1045	1054	1048	1054	1053	1056	1052	93	44	80	27	78	31	141	26	20
117	6.2	1037	1042	1047	1055	1049	1056	1054	1057	1053	95	44	81	27	79	31	144	26	16
118	7.6	1037	1045	1048	1056	1050	1056	1057	1058	1054	98	45	81	28	79	31	147	27	17
119	7.5	1039	1045	1050	1058	1051	1058	1058	1060	1057	103	46	81	29	79	32	151	27	17
120	7.5	1041	1046	1052	1059	1053	1062	1059	1061	1058	108	46	81	29	80	32	155	27	16
121	7.1	1042	1047	1051	1059	1051	1059	1059	1061	1058	114	47	82	29	80	32	157	28	16
122	5.5	1042	1048	1052	1060	1047	1058	1060	1061	1060	114	48	82	29	81	32	162	29	16
123	6.9	1046	1053	1056	1060	1048	1063	1061	1063	1062	117	49	83	30	81	32	166	30	26
124	5	1047	1056	1065	1065	1050	1063	1064	1064	1061	119	51	83	30	81	33	169	31	18
125	6.8	1052	1060	1075	1058	1052	1067	1059	1063	1060	116	52	84	30	81	33	171	32	16
126	6.7	1055	1061	1074	1058	1053	1070	1061	1065	1061	115	54	85	30	82	33	178	33	28
127	6.4	1056	1064	1079	1061	1055	1072	1063	1067	1062	128	61	85	30	83	34	183	33	17
128	7.5	1054	1066	1082	1064	1056	1072	1065	1069	1062	127	93	86	31	83	34	189	34	16
129	7.3	1056	1070	1083	1064	1058	1073	1066	1069	1063	156	127	87	31	84	34	195	34	16
130	7.5	1060	1072	1085	1066	1059	1076	1068	1070	1066	56	145	88	31	85	35	201	34	16
131	7.5	1061	1074	1077	1066	1061	1072	1067	1070	1067	11	71	89	32	87	35	208	34	15
132	8	1061	1070	1083	1066	1061	1067	1065	1069	1067	8	33	90	32	89	35	214	35	15

Time	Chan 19	Chan 20	Chan 21	Chan 22	Chan 23	Chan 24	Chan 25	Chan 32	Chan 33	Chan 34	Chan 35	Chan 38
min	°C	°C	°C	°C	°C	°C	°C	°C	°C	°C	°C	°C
0	17	16	15	16	16	16	16	15	15	16	15	15
1	40	17	38	17	35	18	40	11	28	17	40	15
2	44	20	-1212	18	52	33	60	12	33	19	55	15
3	48	28	-1212	21	61	42	67	-1212	108	29	123	15
4	61	30	-1212	22	67	41	64	-18	101	47	121	15
5	86	30	-1212	22	65	40	59	970	93	54	112	15
6	105	29	-1212	23	62	37	55	617	85	57	105	14
7	107	28	-523	24	59	39	52	-597	79	56	99	14
8	105	28	-554	24	56	38	50	770	72	54	92	14
9	100	27	-1212	25	53	42	48	1247	66	52	85	13
10	93	27	-1212	27	50	43	45	1247	60	49	80	13
11	85	27	-1212	30	47	41	42	213	54	48	75	13
12	78	27	-1213	33	45	41	40	-229	49	47	70	13
13	71	27	-1213	36	43	44	38	-305	45	51	65	12
14	65	28	-1213	39	41	52	36	229	42	52	61	12
15	60	29	-1213	42	40	60	34	810	39	56	57	12
16	56	30	-1213	49	39	64	33	1246	36	64	54	12
17	52	32	-1213	53	38	65	31	1246	34	65	50	12
18	49	35	-1213	56	38	66	30	274	32	69	48	12
19	47	37	-1213	60	37	67	29	713	31	70	45	11
20	45	40	-1214	63	37	67	28	-824	30	71	42	11
21	44	42	-1214	66	37	68	28	-1214	28	74	40	11
22	43	44	-1214	66	37	68	27	-1214	28	76	38	11
23	41	46	-1214	65	37	68	26	-1214	27	79	36	11

Time	Chan 19	Chan 20	Chan 21	Chan 22	Chan 23	Chan 24	Chan 25	Chan 32	Chan 33	Chan 34	Chan 35	Chan 38
min	°C	°C	°C	°C	°C	°C	°C	°C	°C	°C	°C	°C
24	40	47	-1214	63	37	69	26	-1214	26	80	35	11
25	39	48	-1214	62	37	68	26	-1214	26	77	33	11
26	38	48	-1214	61	37	69	26	-1214	25	77	32	11
27	36	49	-1214	60	37	69	26	-1214	25	77	30	11
28	35	49	-1215	59	37	70	26	-1215	25	75	29	11
29	35	50	-1215	59	37	70	25	-1215	24	76	28	11
30	34	51	-1215	58	37	70	25	-738	24	75	28	11
31	33	51	-1215	58	38	70	25	-661	24	75	27	11
32	32	52	-1215	58	38	70	26	-700	24	73	26	11
33	32	52	-1215	58	38	69	25	-708	24	74	26	11
34	31	51	-1215	58	38	69	25	-819	24	72	26	11
35	31	53	-1215	58	38	70	26	-868	24	71	25	11
36	30	53	-1215	58	39	70	26	-788	24	70	25	11
37	30	53	-1215	58	39	71	26	-836	24	70	25	11
38	29	54	-1216	58	39	71	26	-983	24	70	25	11
39	29	55	-1216	59	39	71	26	-1046	24	69	24	11
40	29	55	-1216	59	39	71	26	-1103	24	70	24	11
41	29	55	-1216	60	39	71	26	-1216	24	70	24	11
42	28	55	-1216	60	40	71	26	136	25	70	24	11
43	28	56	-1216	60	40	72	26	-944	25	69	24	11
44	28	56	-1216	60	40	72	26	-982	25	70	24	11
45	28	56	-1216	60	40	73	26	-976	25	70	24	11
46	28	56	-1216	61	40	74	26	-953	25	71	24	11
47	27	57	-1216	61	40	74	26	-823	25	72	24	11

Time	Chan 19	Chan 20	Chan 21	Chan 22	Chan 23	Chan 24	Chan 25	Chan 32	Chan 33	Chan 34	Chan 35	Chan 38
min	°C	°C	°C	°C	°C	°C	°C	°C	°C	°C	°C	°C
48	27	58	-1216	61	40	74	26	-537	25	71	24	11
49	27	58	-1216	62	40	74	26	-512	25	71	24	11
50	27	58	-1216	62	40	74	26	-537	25	72	24	11
51	27	58	-1051	63	41	75	26	-559	25	71	24	11
52	27	59	-959	63	41	75	26	-532	25	73	24	11
53	27	60	-1216	65	41	76	26	-686	25	73	24	11
54	27	60	-1216	66	42	76	26	-892	25	74	24	11
55	27	60	-834	67	42	76	26	-1009	25	76	24	11
56	27	61	-636	67	42	76	26	-1216	25	77	24	11
57	26	61	-603	68	42	76	26	-1217	25	79	24	10
58	26	62	-782	69	42	77	26	-1217	25	78	24	10
59	26	62	-810	70	42	77	26	-1217	25	78	24	10
60	26	62	-354	70	42	77	26	-1217	25	81	24	10
61	26	62	-487	70	42	77	26	-1217	25	85	24	10
62	26	62	-318	71	42	77	26	-1217	25	88	24	11
63	26	62	-597	71	42	78	26	-1217	25	91	23	10
64	26	62	-1217	71	42	79	26	-1217	25	90	23	11
65	26	62	-1131	71	42	79	26	-1217	24	89	23	10
66	26	62	-1085	71	41	81	26	-1217	24	88	23	11
67	25	61	-1217	71	41	82	25	-1217	24	88	23	10
68	25	62	-1217	72	40	86	25	-1217	24	88	23	10
69	25	62	-1217	72	40	85	25	-1217	24	90	23	10
70	25	62	-1217	72	39	87	25	-1217	24	92	23	10
71	25	63	-1217	72	39	88	25	-1217	24	96	23	10

Time	Chan 19	Chan 20	Chan 21	Chan 22	Chan 23	Chan 24	Chan 25	Chan 32	Chan 33	Chan 34	Chan 35	Chan 38
min	°C	°C	°C	°C	°C	°C	°C	°C	°C	°C	°C	°C
72	25	63	-1217	72	39	84	25	-1217	24	100	23	10
73	25	63	-1217	73	38	79	25	-1217	24	102	23	10
74	24	63	-1217	73	38	78	25	-1217	24	104	23	10
75	24	63	-1217	73	38	79	25	-1217	24	107	23	10
76	24	64	-1217	74	38	80	25	-1217	23	110	23	10
77	24	66	-1217	74	38	79	25	-1217	23	112	23	10
78	24	66	-1217	74	37	72	25	-1217	23	114	23	10
79	24	65	-1217	75	37	72	25	-1217	24	117	23	10
80	24	64	-1217	75	37	71	25	-1217	23	116	23	10
81	24	65	-1217	75	37	71	25	-1217	23	115	23	10
82	24	65	-1217	75	37	73	25	-1217	23	114	23	10
83	24	65	-1217	75	37	70	25	-1217	23	116	22	10
84	24	66	-1217	75	37	68	25	-1217	23	118	22	10
85	24	66	-1217	75	37	71	25	-1217	23	119	22	10
86	24	67	-1217	75	37	70	25	-1217	23	122	22	10
87	24	68	-1217	75	36	71	24	-1217	23	122	22	10
88	24	69	-1217	75	36	70	24	-1217	23	126	22	10
89	24	69	-1217	76	36	67	24	-1217	23	126	22	10
90	24	69	-1217	76	35	66	24	-1217	23	127	22	10
91	24	69	-1217	76	35	56	24	-1217	24	124	22	10
92	24	69	-1217	77	35	53	24	-1217	24	122	22	10
93	24	70	-1217	77	35	52	24	-1217	24	125	22	10
94	25	70	-1217	78	34	50	24	-1217	24	127	22	10
95	25	70	-1217	78	34	48	24	-1032	24	130	22	10



Time	Chan 19	Chan 20	Chan 21	Chan 22	Chan 23	Chan 24	Chan 25	Chan 32	Chan 33	Chan 34	Chan 35	Chan 38
min	°C	°C	°C	°C	°C	°C	°C	°C	°C	°C	°C	°C
96	25	71	-1217	81	34	46	24	-1159	24	133	22	10
97	25	71	-1217	80	33	45	24	-1217	24	134	22	10
98	25	71	-1217	82	33	44	24	-954	23	135	22	10
99	25	70	-1217	83	33	42	24	-1069	24	136	22	11
100	25	70	-1217	84	32	41	24	-904	24	139	22	11
101	25	70	-1217	85	32	40	24	-818	24	144	22	11
102	25	70	-1217	86	31	39	24	-699	24	144	22	11
103	25	69	-1217	88	31	38	24	-564	23	149	22	11
104	25	69	-1217	90	31	38	24	-123	24	150	22	11
105	25	70	-1217	92	31	40	24	409	24	146	22	11
106	25	70	-1217	94	30	39	24	1243	24	135	22	11
107	25	71	-1217	96	30	39	24	1243	24	129	22	11
108	25	72	-1217	99	30	41	24	1243	24	129	22	11
109	25	73	-1217	101	30	41	24	1231	24	131	22	11
110	25	73	-1217	101	30	42	24	1101	24	133	22	11
111	26	74	-1217	103	30	42	25	1011	24	133	22	11
112	26	74	-1217	104	30	40	25	841	24	130	22	11
113	26	74	-1217	106	30	40	25	888	24	129	22	11
114	26	74	-1217	106	30	39	25	938	24	131	23	11
115	27	74	-1217	105	30	38	25	1243	25	133	23	11
116	27	74	-1217	105	30	36	25	1243	25	140	23	11
117	27	74	-1217	105	30	35	25	1243	25	147	23	11
118	28	75	-1217	105	31	36	25	1243	25	150	23	11
119	29	75	-1216	107	31	41	26	1243	25	162	23	11





Time	Chan 19	Chan 20	Chan 21	Chan 22	Chan 23	Chan 24	Chan 25	Chan 32	Chan 33	Chan 34	Chan 35	Chan 38
min	°C	°C	°C	°C	°C	°C	°C	°C	°C	°C	°C	°C
120	31	75	-1216	107	31	40	26	1243	26	185	23	11
121	33	75	-1216	108	31	36	26	601	26	213	23	11
122	34	75	-1216	114	32	38	27	-1216	27	208	24	11
123	36	76	-1216	121	35	43	27	14	30	186	24	11
124	38	76	-1216	121	36	46	28	14	30	184	24	11
125	45	77	-1216	122	37	46	29	9	30	184	24	11
126	46	79	-1216	124	38	49	30	14	30	99	22	11
127	47	82	-1216	123	38	52	30	15	29	54	22	11
128	48	85	-1216	124	38	55	31	14	29	36	22	12
129	48	90	-1216	127	38	58	31	15	28	28	22	12
130	48	95	-1216	130	38	63	30	14	28	24	22	12
131	47	101	-1216	132	38	66	30	15	28	23	22	12
132	47	107	-1216	137	38	70	30	14	28	23	23	12