

The approved F/CHWB/BN/RD/DB sounder beacon is part of the VTG family of products designed for use with conventional fire alarm systems including SAV-WIRE® two wire.

The sounder function like all VTG family of products comes as standard with 32 tones. The beacon function has been designed for maximum all round visibility coupled with low power consumption utilising an array of energy efficient LED's.

The sounder function features a two-stage alarm override which is activated by a third negative wire from the fire panel.

Both the sounder and beacon functions are fully synchronised. The sounder function has been fully approved to EN54 part 3 by Intertek on tones 1, 3, 8, 11, 25 and 27. The product can also be used as a beacon only which is easily selected by a dial switch at the time of installation.

- sounder function fully approved to EN54-3
- 32 tones plus a selectable override tone
- shallow base IP21C and deep base IP33C versions available
- designed to work with both conventional and two-wire (SAV-WIRE®) systems
- switch selectable beacon only feature
- unique twist and lock bayonet mounting system
- removable cover on deep base for surface wiring
- features base locking system as standard



TECHNICAL

voltage range (Vdc)	21 - 28	
number of tones	32	
operating frequency (Hz)	440 - 2900	
temperature range (°C)	-20 to +70	
flash rate	c. 1Hz	
monitoring	reverse polarity	
protection rating	IP21C (shallow)	IP33C (deep)
boxed weight (kg)	0.22 (shallow)	0.25 (deep)
body colours available	red or white (ABS fire retardant plastic)	
lens colours available	red or amber	

PERFORMANCE

volume setting	high	med	low
sound output, typical (dBA)	99.1	95.4	79.7
sound output, anechoic chamber (dBA)	98.0	94.3	78.5
sound output, reverberation chamber (dBA)	113.6	110.2	96.0
max. current consumption @ 24Vdc (mA)	34.4	19.9	10.8
power consumption @ 24Vdc (mW)	826	478	259

NB: see tone list performance for more accurate current consumption figures

ORDERING INFORMATION

red body, 32 tone, shallow base, red lens	511-095L
red body, 32 tone, shallow base, amber lens	511-099L
red body, 32 tone, deep base, red lens	511-097L
red body, 32 tone, deep base, amber lens	511-101L
white body, 32 tone, shallow base, red lens	511-096L
white body, 32 tone, shallow base, amber lens	511-100L
white body, 32 tone, deep base, red lens	511-098L
white body, 32 tone, deep base, amber lens	511-102L

APPROVALS INFORMATION



0359-CPR-00060



DIMENSIONS

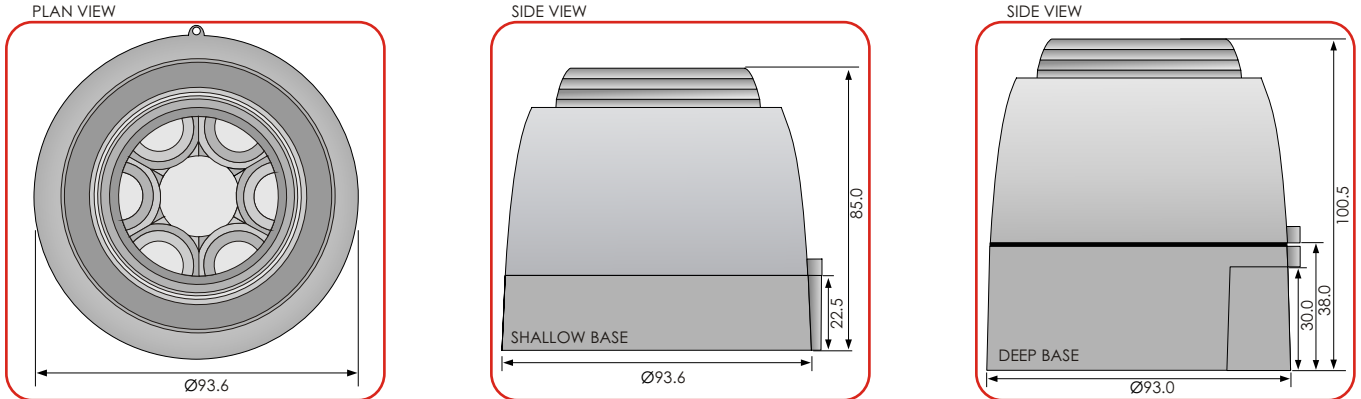

PRODUCT MOUNTING & CABLE ENTRY

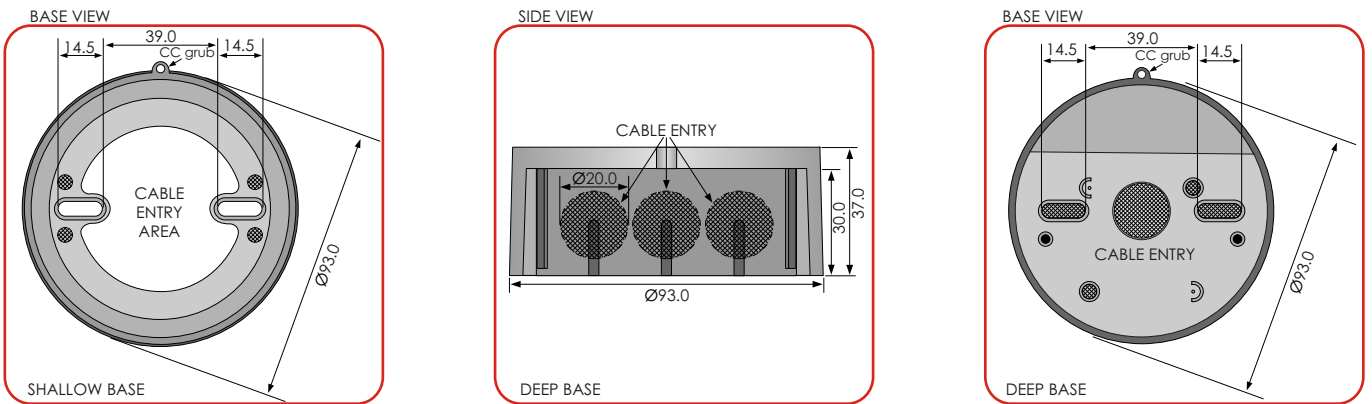

WIRING CONFIGURATION

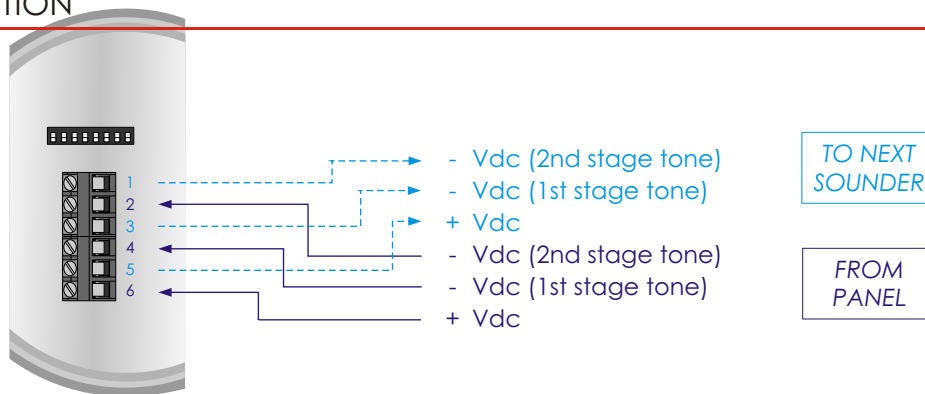

STONE & VOLUME SELECTION

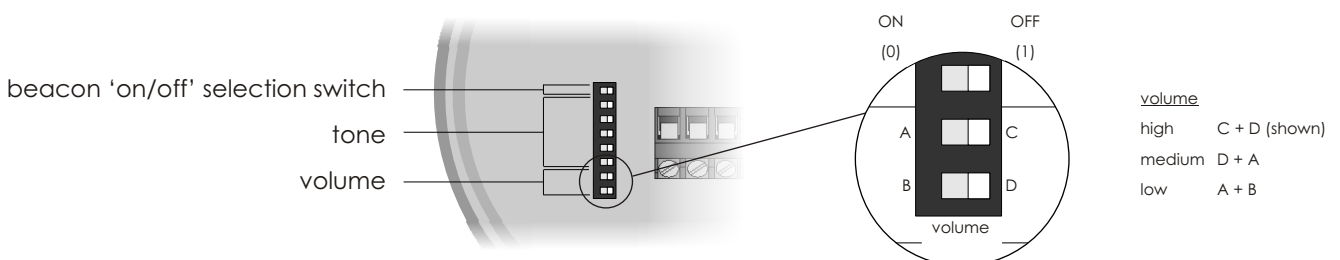

TONE LIST - GRAPHICAL

Tones 1,3,8,11(Second Stage Tone),25 & 27 Approved to EN54-3

no. name	1st stage frequency	1st stage graphical	2nd stage frequency	2nd stage graphical
1 LF Sweep (Cranford sweep)	800-1000Hz swept every 500ms (2Hz)		800Hz continuous	800Hz
2 Alternative warble BS	800Hz for 250ms, then 960Hz for 250ms		800Hz continuous	800Hz
3 Warble Tone BS	800Hz for 500ms, then 1000Hz for 500ms		800Hz continuous	800Hz
4 Alternative warble BS	500Hz for 250ms, then 600Hz for 250ms		500Hz continuous	500Hz
5 HF Back up Interrupted	2800Hz for 1000ms, then off for 1000ms		2800Hz continuous	2800Hz
6 LF Back up Alarm	800Hz for 150ms, then off for 150ms		800Hz continuous	800Hz
7 HF Back up Interrupted (fast)	2800Hz for 150ms, then off for 150ms		800Hz continuous	800Hz
8 LF Continuous tone BS5839	800Hz continuous	800Hz	800Hz continuous	800Hz
9 Sweep - 1Hz	800-900Hz swept every 1000ms (1Hz)		800Hz continuous	800Hz
10 Australian slow whoop	970Hz for 625ms, then off for 150ms		500-1200Hz for 3250ms, then off for 250ms	
11 Dutch sweep	970Hz continuous	970Hz	500-1200Hz for 3500ms, then off for 500ms	
12 Analogue sweep	500-600Hz swept every 500ms (2Hz)		500Hz continuous	500Hz
13 Sweep - 3Hz	800-970Hz swept every 333ms (3Hz)		800Hz continuous	800Hz
14 Alternate HF slow sweep	2350-2900Hz swept every 333ms (3Hz)		2400Hz continuous	2400Hz
15 Fast HF sweep	2400-2800Hz swept every 143ms (7Hz)		2400Hz continuous	2400Hz
16 US Temporal Pattern LF	950Hz for 500ms on, 500ms off (x3), then 1500ms off		800Hz continuous	800Hz
17 Interrupted BS	800Hz for 500ms, then off for 500ms		800Hz continuous	800Hz
18 ISO 8201 LF BS5839 Pt 1	970Hz for 500ms, then off for 500ms		970Hz for 500ms, then off for 500ms	970Hz
19 Interrupted medium	1000Hz for 250ms, then off for 250ms		800Hz continuous	800Hz
20 ISO8201 HF	2850Hz for 500ms, then off for 500ms		2850Hz for 500ms, then off for 500ms	2850Hz
21 Continuous	1000Hz continuous	1000Hz	1000Hz continuous	1000Hz
22 LF Buzz	800-950Hz swept every 9ms (110Hz)		800Hz continuous	800Hz
23 HF Continuous	2800Hz continuous	2800Hz	2800Hz continuous	2800Hz
24 Sweep	800-970Hz swept every 111ms (9Hz)		800Hz continuous	800Hz
25 German DIN tone	1200-500Hz swept every 1000ms (1Hz)		800Hz continuous	800Hz
26 Swedish Fire signal	660Hz for 150ms, then off for 150ms		660Hz for 150ms, then off for 150ms	660Hz
27 French tone AFNOR	554Hz for 100ms, then 440Hz for 400ms		800Hz continuous	800Hz
28 Swedish all clear signal	660Hz continuous	660Hz	660Hz continuous	660Hz
29 US Temporal Pattern HF	2900Hz for 500ms on, 500ms off (x3), then 1500ms off		2900Hz continuous	2900Hz
30 Siren 2 way ramp (short)	500-1200Hz rising for 250ms, then falling for 250ms		800Hz continuous	800Hz
31 FP1063.1-Telecom	800Hz for 250ms, then 970Hz for 250ms		800Hz continuous	800Hz
32 Siren 2 way ramp (long)	500-1200Hz rising for 3000ms, then falling for 3000ms		800Hz continuous	800Hz

TONE LIST - PERFORMANCE

Tones 1,3,8,11(Second Stage Tone),25 & 27 Approved to EN54-3

no.	name	1st stage frequency	switch (2345)	typical current (mA)			typical sound output (dBA)		
				low	medium	high	low	medium	high
1	LF Sweep (Cranford sweep)	800-1000Hz swept every 500ms (2Hz)	11111	10.2	14.8	23.0	80.1	95.6	99.9
2	Alternative warble BS	800Hz for 250ms, then 960Hz for 250ms	11110	9.9	14.6	19.2	80.4	95.7	100.0
3	Warble Tone BS	800Hz for 500ms, then 1000Hz for 500ms	11101	9.9	14.7	18.9	79.7	94.7	98.5
4	Alternative warble BS	500Hz for 250ms, then 600Hz for 250ms	11100	9.1	12.7	14.9	80.0	95.8	99.1
5	HF Back up Interrupted	2800Hz for 1000ms, then off for 1000ms	11011	12.4	19.4	28.9	79.2	93.7	101.0
6	LF Back up Alarm	800Hz for 150ms, then off for 150ms	11010	10.7	15.0	18.2	78.6	93.6	97.2
7	HF Back up Interrupted (fast)	2800Hz for 150ms, then off for 150ms	11001	11.8	19.4	28.8	78.3	92.9	99.9
8	LF Continuous tone BS5839	800Hz continuous	11000	9.6	14.0	17.4	79.8	94.7	98.4
9	Sweep - 1Hz	800-900Hz swept every 1000ms (1Hz)	10111	9.9	14.8	19.2	80.2	95.6	99.8
10	Australian slow whoop	970Hz for 625ms, then off for 150m	10110	9.9	15.6	19.5	80.2	95.5	99.9
11	Dutch sweep	970Hz continuous	10101	10.1	15.0	19.6	80.2	95.5	100.1
12	Analogue sweep	500-600Hz swept every 500ms (2Hz)	10100	9.1	12.6	14.7	80.2	94.8	97.8
13	Sweep - 3Hz	800-970Hz swept every 333ms (3Hz)	10011	9.9	15.0	19.0	80.2	95.7	100.0
14	Alternate HF slow sweep	2350-2900Hz swept every 333ms (3Hz)	10010	11.4	19.3	34.5	83.7	95.7	104.6
15	Fast HF sweep	2400-2800Hz swept every 143ms (7Hz)	10001	11.4	19.6	34.4	82.6	97.1	104.2
16	US Temporal Pattern LF	950Hz for 500ms on, 500ms off (x3), then 1500ms off	10000	10.4	15.1	19.6	80.6	96.0	100.5
17	Interrupted BS	800Hz for 500ms, then off for 500ms	01111	9.2	15.1	18.4	79.6	94.5	98.3
18	ISO 8201 LF BS5839 Pt 1	970Hz for 500ms, then off for 500ms	01110	9.2	14.6	20.5	80.1	95.4	99.9
19	Interrupted medium	1000Hz for 250ms, then off for 250ms	01101	11.0	16.0	20.2	78.5	93.8	98.0
20	ISO8201 HF	2850Hz for 500ms, then off for 500ms	01100	12.1	17.5	28.3	79.4	93.4	100.7
21	Continuous	1000Hz continuous	01011	10.2	15.1	20.1	78.9	94.2	98.7
22	LF Buzz	800-950Hz swept every 9ms (110Hz)	01010	9.8	14.7	18.9	79.9	95.3	99.5
23	HF Continuous	2800Hz continuous	01001	11.3	18.6	29.3	79.3	93.8	101.1
24	Sweep	800-970Hz swept every 111ms (9Hz)	01000	9.7	14.6	18.9	80.1	95.5	99.7
25	German DIN tone	1200-500Hz swept every 1000ms (1Hz)	00111	9.7	13.5	20.9	79.5	95.0	99.0
26	Swedish Fire signal	660Hz for 150ms, then off for 150ms	00110	10.4	14.3	17.0	76.0	91.9	95.6
27	French tone AFNOR	554Hz for 100ms, then 440Hz for 400ms	00101	9.1	11.9	15.6	76.9	93.1	95.9
28	Swedish all clear signal	660Hz continuous	00100	9.3	13.2	16.2	77.1	93.1	96.8
29	US Temporal Pattern HF	2900Hz for 500ms on, 500ms off (x3), then 1500ms off	00011	11.3	18.3	28.9	79.2	93.1	100.4
30	Siren 2 way ramp (short)	500-1200Hz rising for 250ms, then falling for 250ms	00010	9.4	13.6	17.6	79.2	94.6	98.7
31	FP1063.1-Telecom	800Hz for 250ms, then 970Hz for 250ms	00001	9.8	15.9	19.6	80.2	95.5	100.0
32	Siren 2 way ramp (long)	500-1200Hz rising for 3000ms, then falling for 3000ms	00000	9.9	15.0	19.7	81.0	95.9	100.2

EN54-3 APPROVED MINIMUM SOUND OUTPUT AT 1 METRE - LOW VOLUME

<u>Tone 1 - Cranford Sweep</u>					
Horizontal Plane			Vertical Plane		
Angle	21V	28V	Angle	21V	28V
15°	66.54	69.64	15°	65.94	69.14
45°	72.44	75.54	45°	72.24	75.34
75°	72.54	75.64	75°	72.44	75.64
105°	72.54	75.74	105°	72.44	75.54
135°	72.44	75.54	135°	73.24	76.34
165°	65.74	68.94	165°	66.14	69.24

<u>Tone 8 - Continuous 800Hz Tone</u>					
Horizontal Plane			Vertical Plane		
Angle	21V	28V	Angle	21V	28V
15°	62.14	64.54	15°	61.14	64.24
45°	69.14	72.14	45°	68.74	71.84
75°	70.94	74.04	75°	70.84	73.94
105°	71.64	74.64	105°	70.74	73.74
135°	68.24	71.24	135°	69.84	72.94
165°	60.94	64.04	165°	59.94	63.14

<u>Tone 11 - Dutch Sweep Tone</u>					
Horizontal Plane			Vertical Plane		
Angle	21V	28V	Angle	21V	28V
15°	66.34	69.54	15°	66.04	69.14
45°	72.44	75.54	45°	72.34	75.34
75°	73.64	76.74	75°	73.14	76.24
105°	73.24	76.44	105°	73.44	76.54
135°	72.34	75.44	135°	72.74	75.74
165°	65.94	69.04	165°	66.14	69.34

<u>Tone 25 - German DIN Tone</u>					
Horizontal Plane			Vertical Plane		
Angle	21V	28V	Angle	21V	28V
15°	64.44	67.54	15°	63.94	67.04
45°	71.14	74.14	45°	70.94	74.04
75°	71.74	74.84	75°	71.34	74.54
105°	71.54	74.74	105°	71.54	74.74
135°	70.64	73.74	135°	71.14	74.34
165°	63.94	67.04	165°	64.24	67.34

<u>Tone 27 - French AFNOR Tone</u>					
Horizontal Plane			Vertical Plane		
Angle	21V	28V	Angle	21V	28V
15°	61.54	64.64	15°	60.44	63.34
45°	69.14	72.14	45°	68.84	71.84
75°	68.54	71.64	75°	68.34	71.34
105°	68.54	71.54	105°	68.84	71.84
135°	68.24	71.24	135°	69.44	72.44
165°	61.64	64.74	165°	61.74	64.74

EN54-3 APPROVED POLAR DIAGRAMS - LOW VOLUME

Tone 1 - Cranford Sweep

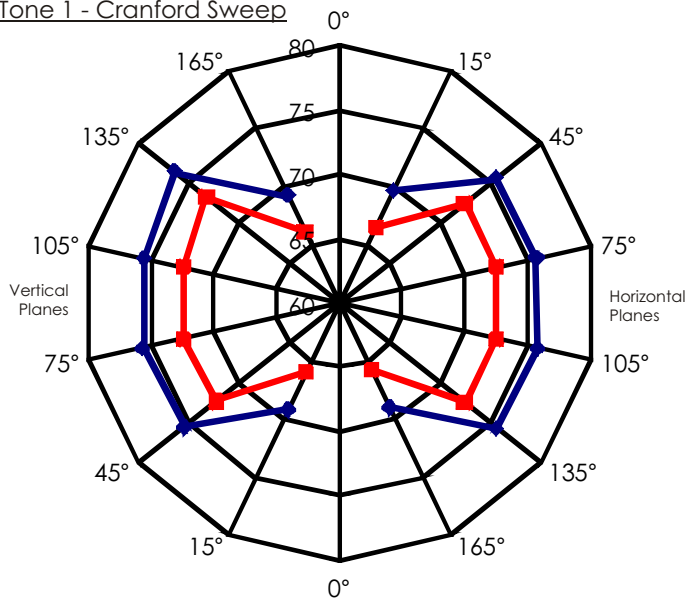

Continuous 800Hz Tone
15° (Override Tone)

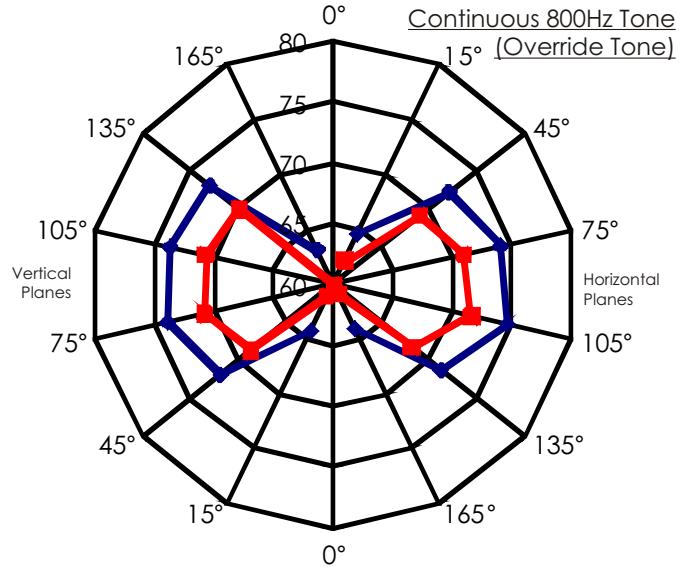

Tone 11 - Dutch Sweep Tone

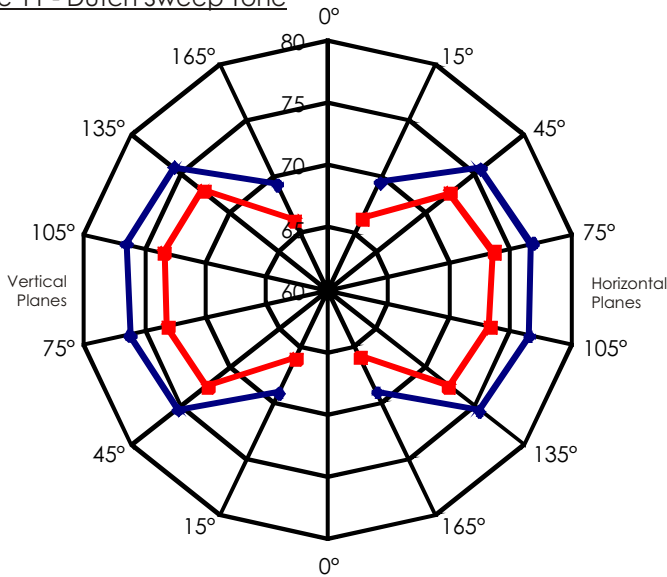

Tone 25 - German DIN Tone

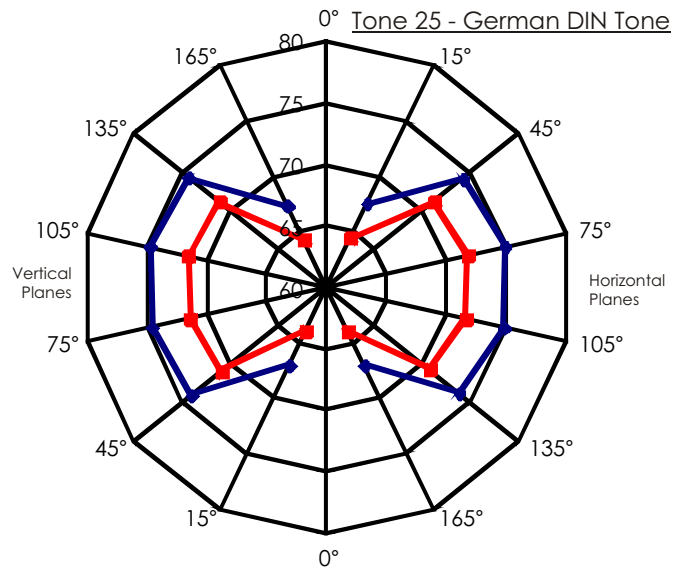

Tone 27 - French AFNOR Tone

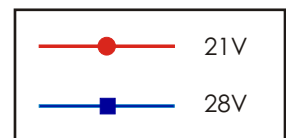
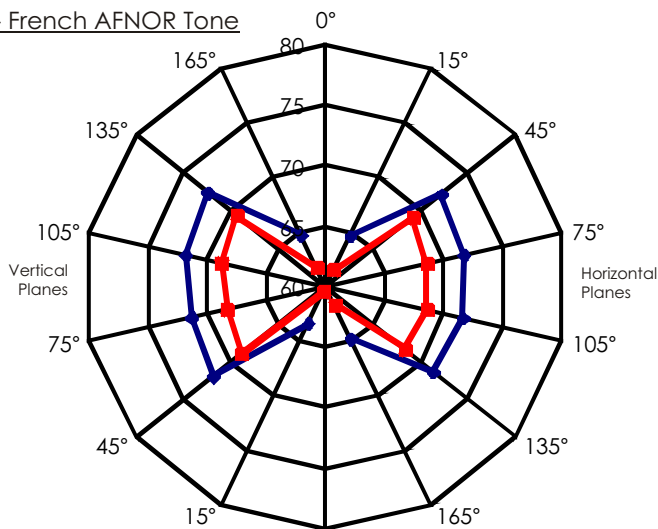

EN54-3 APPROVED MINIMUM SOUND OUTPUT AT 1 METRE - HIGH VOLUME

<u>Tone 1 - Cranford Sweep</u>					
Horizontal Plane			Vertical Plane		
Angle	21V	28V	Angle	21V	28V
15°	89.14	91.44	15°	88.64	91.04
45°	94.44	96.64	45°	94.14	96.44
75°	94.94	97.24	75°	94.84	97.24
105°	94.84	97.24	105°	94.94	97.14
135°	94.34	96.64	135°	95.14	97.34
165°	88.24	90.54	165°	88.54	90.84

<u>Tone 8 - Continuous 800Hz Tone</u>					
Horizontal Plane			Vertical Plane		
Angle	21V	28V	Angle	21V	28V
15°	81.04	83.44	15°	82.14	84.54
45°	89.74	91.94	45°	89.24	91.54
75°	91.14	93.44	75°	91.24	93.54
105°	92.44	94.64	105°	91.34	93.54
135°	89.04	91.24	135°	90.54	92.84
165°	81.94	84.24	165°	81.34	83.64

<u>Tone 11 - Dutch Sweep Tone</u>					
Horizontal Plane			Vertical Plane		
Angle	21V	28V	Angle	21V	28V
15°	89.14	91.44	15°	88.84	91.14
45°	94.34	96.64	45°	94.34	96.64
75°	95.14	97.44	75°	94.94	97.24
105°	95.04	97.34	105°	95.04	97.34
135°	94.44	96.64	135°	94.44	96.64
165°	88.44	90.64	165°	88.64	90.94

<u>Tone 25 - German DIN Tone</u>					
Horizontal Plane			Vertical Plane		
Angle	21V	28V	Angle	21V	28V
15°	86.84	89.14	15°	86.44	88.74
45°	92.64	94.84	45°	92.54	94.84
75°	93.64	95.94	75°	93.44	95.74
105°	93.54	95.84	105°	93.54	95.84
135°	92.34	94.54	135°	92.84	95.14
165°	86.24	88.44	165°	86.44	88.74

<u>Tone 27 - French AFNOR Tone</u>					
Horizontal Plane			Vertical Plane		
Angle	21V	28V	Angle	21V	28V
15°	82.84	85.04	15°	81.74	83.94
45°	89.84	92.04	45°	89.84	91.94
75°	89.74	91.94	75°	89.34	91.64
105°	89.84	92.14	105°	89.84	92.14
135°	89.24	91.34	135°	90.44	92.54
165°	82.74	85.04	165°	82.84	85.04

EN54-3 APPROVED POLAR DIAGRAMS - HIGH VOLUME

Tone 1 - Cranford Sweep

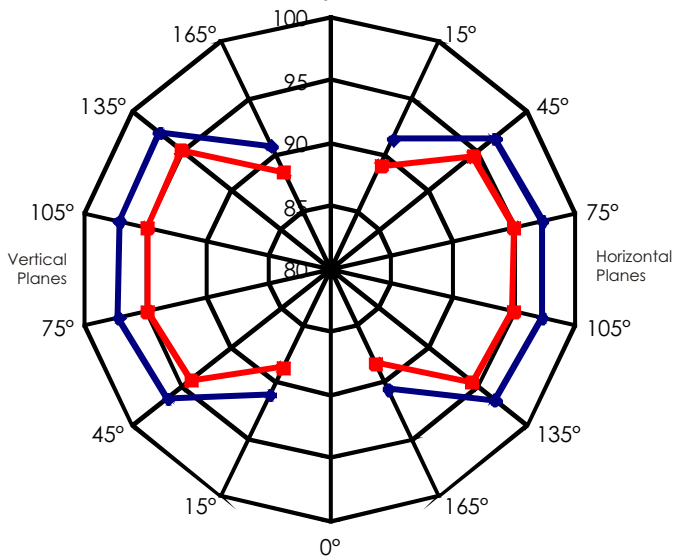

Continuous 800Hz Tone (Override Tone)

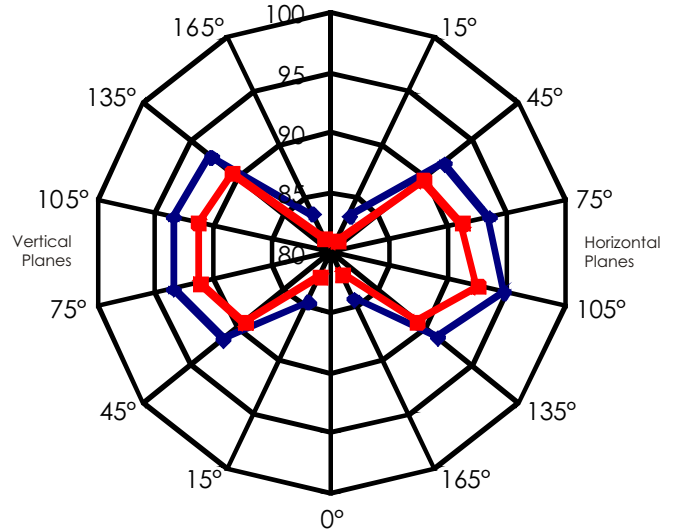

Tone 11 - Dutch Sweep Tone

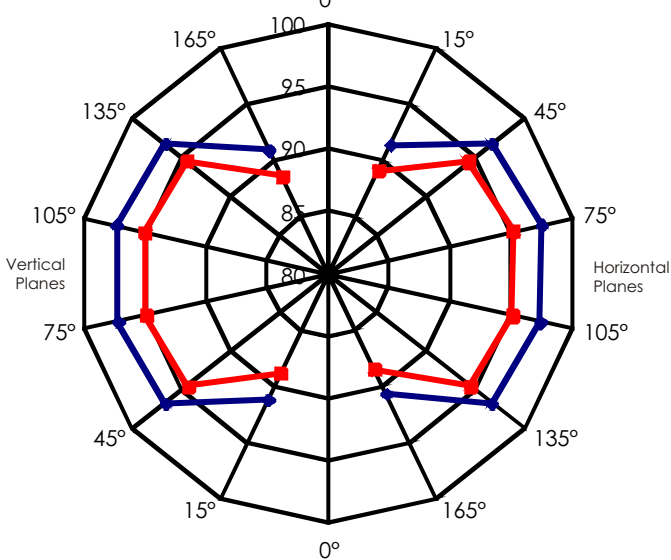

Tone 25 - German DIN Tone

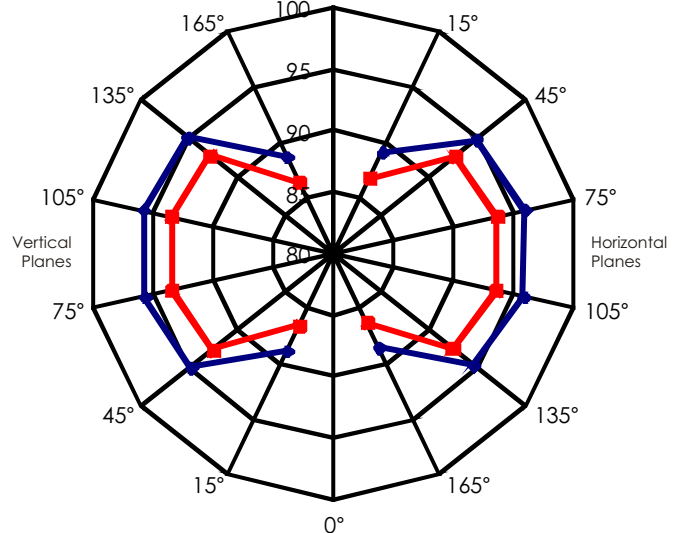

Tone 27 - French AFNOR Tone

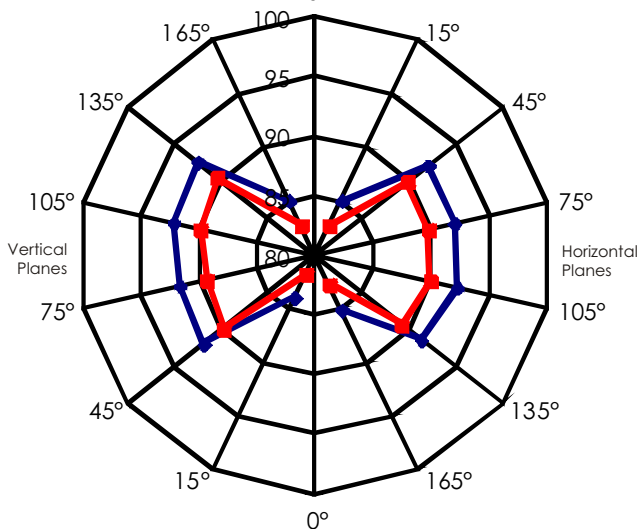

INS 1097 V1.0U

