

Introduction

The Sabre sounder allows for audible indication when the fire alarm system enters a fire alarm condition. This device is compatible with the Twinflex 2-wire range of fire alarm equipment and comprises of a 2-wire zone powered sounder. The device may be installed on the same zone as the Twinflex ASD detector/sounder and associated Twinflex devices.



Before Installation

The sounder must be installed in compliance with the control panel installation manual (26-0959). The installation must also meet the requirements of any local authority. For maximum performance the sounder should be installed in compliance with BS5839 Pt1.

Spacing

The sounder should be mounted securely and care should be taken to ensure the device is accessible for future testing or replacement. CSS recommends spacing of sounders in accordance with EN54 Pt3, and any local authority requirements.

Device Installation

Fix the back box in a suitable position using at least two screw holes/slots, remembering to allow enough cable length for installation. All wiring must be installed in compliance with the recommendations laid out by any local authority as well as any special recommendations documented in the control panel installation manual.

Care should be taken when terminating devices to ensure all cables are correctly sleeved and connections are secure. Improper connections will prevent a system from responding properly in the event of a fire. This product is maintenance free do not attempt disassembly.

Follow the steps below to ensure the IP65 rating is maintained.

1. Drill suitable holes in the base for IP65 rated gland type using O rings to maintain the rating.
2. Affix the Base to the wall using the slots in the base for the screws and using the supplied gasket fitted to maintain the IP65 rating.
3. Fit product to the base using the supplied O ring to maintain the IP65 rating.

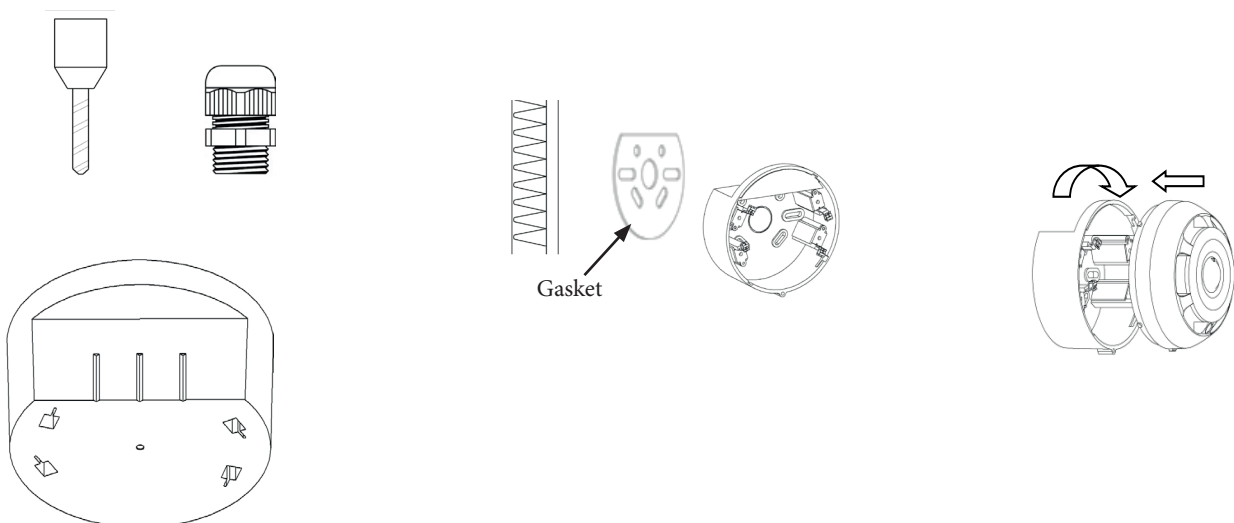

Connections

The cabling used should be of a 2-core 1.5mm² screened, fire resistant type (e.g. FP200 equivalent), and is to be wired in the form of a screened 2-core radial circuit (with no spurs) from the control panel, terminating at the last (“End of Line”) device. It is important to maintain the SCRN continuity in order to protect against data corruption from interference.

Once all testing has been carried out on the cabling and continuity and insulation has been proven and after the DIP switch programming is completed, the sounder front may be fitted. The sounder front is fitted by locating the rubber seal in the groove on the back box to maintain IP65 rating and inserting the front using the tabs then twisting clockwise until locked.

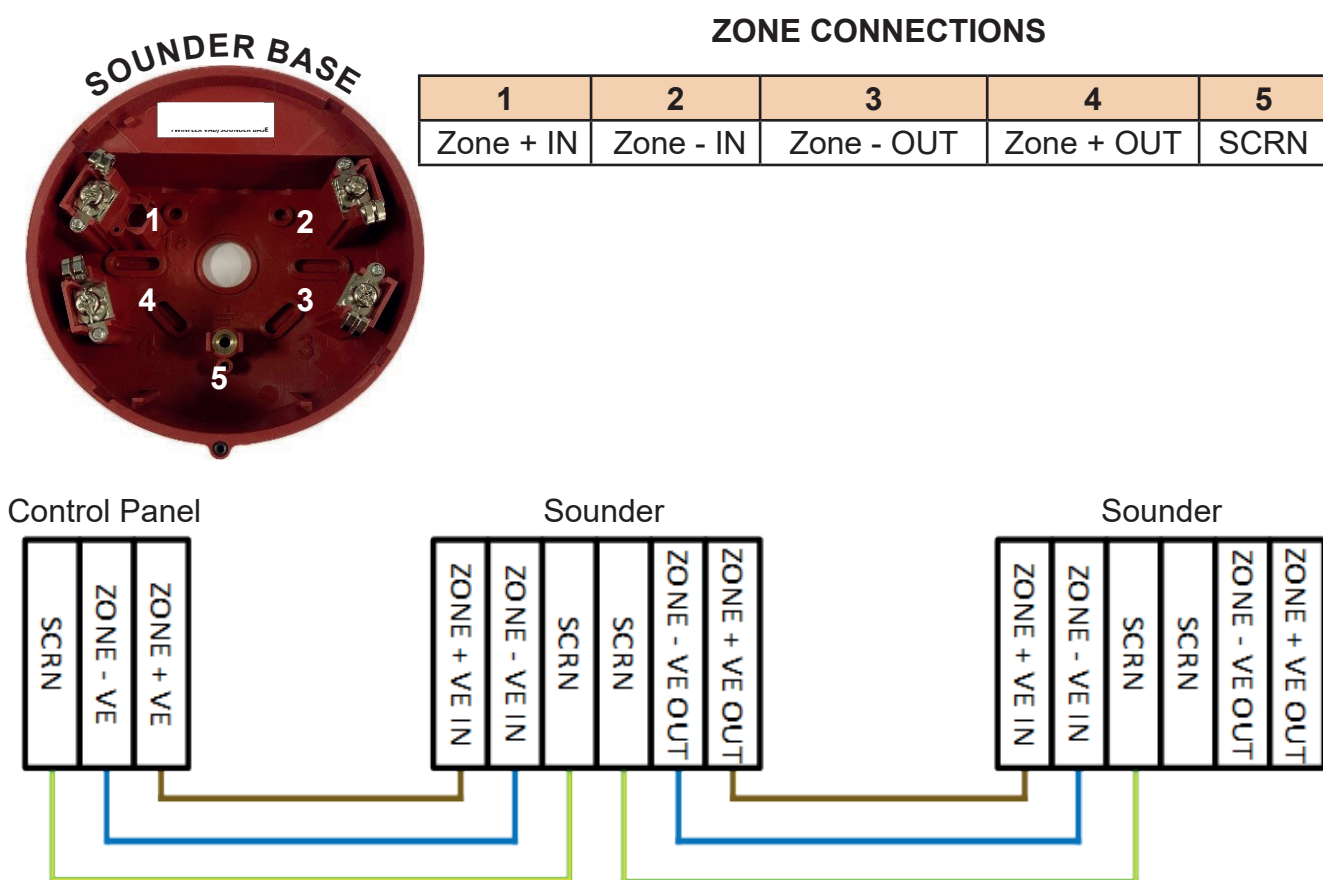

The sounder can be mixed on the same zone as other types of Sabre device (eg. Sabre ASD detectors). The above diagram shows how to make the zone positive, zone negative and SCRN connections between the control panel and sounder. Refer to the instructions of other Twinflex devices for their equivalent wiring/terminal labelling details.

Please note that the “SCRN” terminals on the sounder should only be connected to the zone cable SCRN and NOT to the building earth or the back box earth terminal. The cable SCRN is connected to earth at the panel end only, via the zone “SCRN” terminal (or earth terminal on the Twinflex Pro² 2/4/8 Zone panels). It is important to maintain the SCRN continuity in order to protect against data corruption from interference.

DIP Switch Settings

The sounder DIP switches may be used to program the operation of the Sabre sounder. They may be altered whilst the device is still powered or the system may be powered down completely. The last device on the circuit must have the EOL signal enabled (switch number 1 in the 'ON' position).

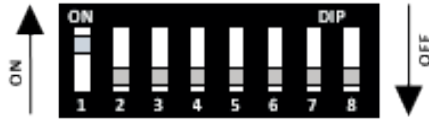

		DIP SWITCH SETTINGS							
		1	2	3	4	5	6	7	8
End Of Line	Enabled	ON							
	Disabled	OFF							
Sound Levels	High				ON				
	Low				OFF				
Sound Patterns	Disabled (No Sound)					OFF	OFF	OFF	OFF
	Sound 1 - Alternate Tone 800-970 Hz (970Hz,0.25s, 800Hz,0.25s)					OFF	ON	ON	OFF
	Sound 2 - Continuous 970 Hz					ON	OFF	ON	OFF
	Sound 3 - Sweep Up 800 to 970Hz (Over 1s)					ON	ON	ON	OFF

Technical Data

Dimensions	Diameter.....	104 mm
	Height.....	80mm
Operating Temperature	-25°C to +75°C
Voltage Ranges	DC Output from Mains Powered Panel.....	25.5 to 35.5V DC
	DC Output from Battery Powered Panel.....	21 to 26V DC
Operating Current (Typical)	Quiescent.....	144 uA
	End of line ON if applicable..... (in addition to Quiescent)	1 mA
	Alarm Sounding.....Sounder High.....	11.0 mA
	Alarm Sounding.....Sounder Low.....	3.0 mA
Power Consumption	Max.....	0.32W
	Min.....	0.096W
Pro² Panel		
Loading Units	Max Loading Units per zone.....	160 DLU
	Sounder High.....	11.00 DLU
	Sounder Low.....	3.00 DLU
Decibel Range	Sounder High.....	95+ dB(A)
	Sounder Low.....	65+ dB(A)
Flammability	UL94-V2
IP Rating	IP 65 + IP33C

Part Code F/CHWB/RD/SA
 Compatability V3,Pro & Pro²

For further advanced technical information please refer to 26-1884

Technical Support

Contact your supplier for technical support on this product.

Due to the complexity and inherent importance of a life risk type system training on this equipment is essential, and commissioning should only be carried out by competent persons. Fike cannot guarantee the operation of any equipment unless all documented instructions are complied with, without variation.

Fike's policy is one of continual improvement and the right to change a specification at any time without notice is reserved. Whilst every care has been taken to ensure that the contents of this document are correct at time of publication, Fike shall be under no liability whatsoever in respect of such contents. E&OE

	
<p>EN54-3: 2014 + 2019 (Type A) F0296337</p> <p>Intended for use in the fire detection and fire alarm Systems in and around buildings</p>	
Essential characteristics	Performance
Nominal activation conditions/Sensitivity, response delay (response time) and performance under fire conditions	Pass
Operational reliability	Pass
Tolerance to supply voltage	Pass
Durability of operational reliability and response delay, Temperature resistance	Pass
Durability of operational reliability, Vibration resistance	Pass
Durability of operational reliability, Humidity resistance	Pass
Durability of operational reliability, Corrosion resistance	Pass
Durability of operational reliability, Electrical stability	Pass
Performance under fire conditions	Pass
Durability of operational reliability, Resistance to Ingress	Pass