

## LEDsmart-BLE2-Rc-MW-Sensor

<div style="border: 1px solid black; padding: 2px; display: inline-block;">Item Code</div>	<div style="border: 1px solid black; padding: 2px; display: inline-block;">kg</div>	
821006001800	0.185kg	

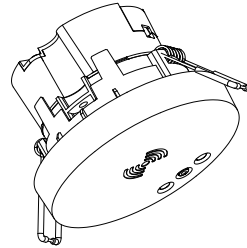

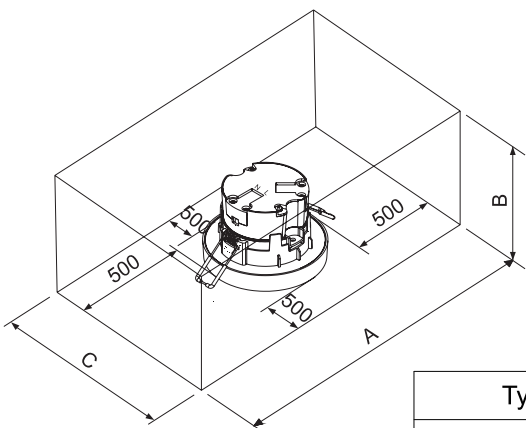
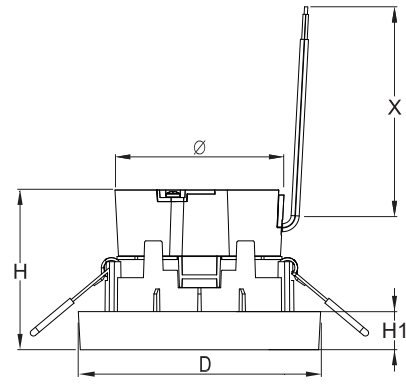

Type	A (mm)	B (mm)	C (mm)	D (mm)	Φ (mm)	H (mm)	H1 (mm)	X (mm)
RY-IOT-SSR-MW-BLE	1000	200	1000	96	64	64	15	1000

①

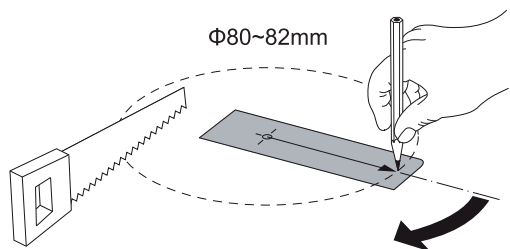

For safe connection make sure to use a 2-way terminal block outlet box that conform to EN60998-2-1 or EN60998-2-2 (450V, 5A, 0.75-2.5mm<sup>2</sup>).

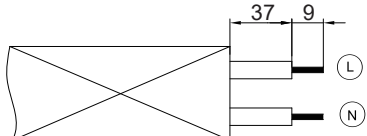

**2 × 0.75mm<sup>2</sup>**

②

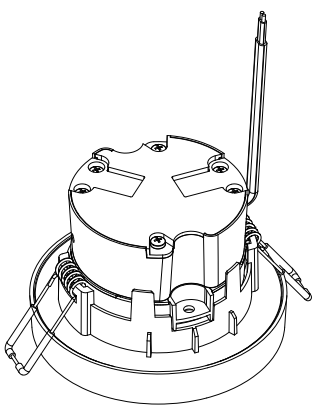

③

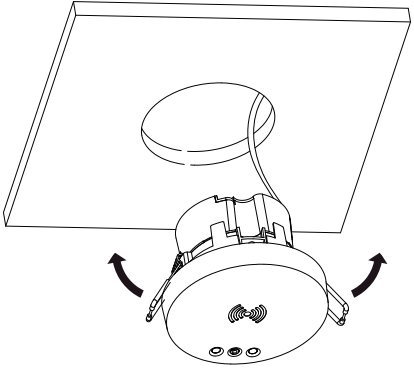

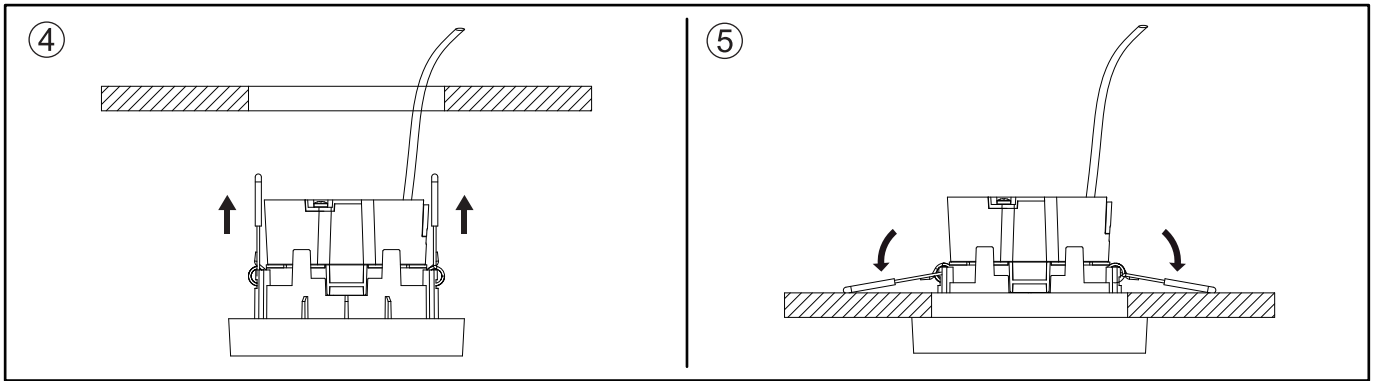

## Reset method

Method 1:

Reset button: Press and hold reset button for 5 seconds.

## Remark

Reset successful when the LED Indicator flashes.

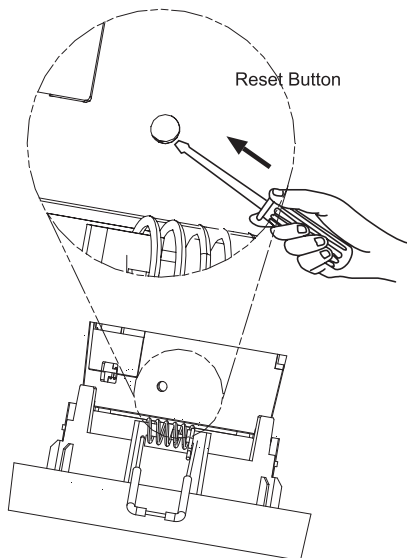

## Detection Range

The sensitivity settings need to be adjusted according to the mounting height to ensure optimal performance.

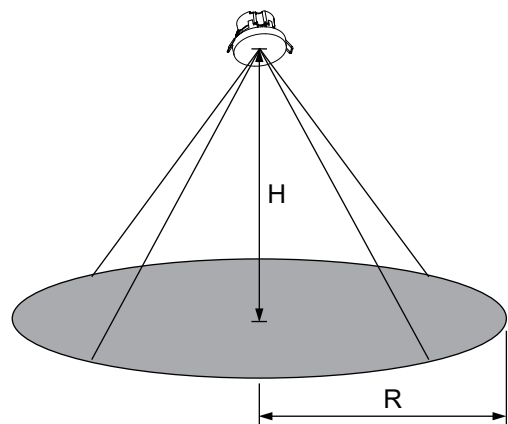

Recommended Height (m)	Sensitivity setting	Detection Radius(m)
3	Low	7
6	Middle	9
9	High	10
12	High	7

## LED Indicator

- 1.Unpaired sensor: LED Indicator will light up for 8h after power on, waiting for network pairing.
- 2.Paired sensor: LED Indicator will light up for 400ms.
- 3.Detection: LED Indicator will flash when the first movement is detected.

Bluetooth Operating Frequency: 2402-2480 MHz Microwave frequency:5.8GHz+/-75MHz, Microwave power < 1mW  
Bluetooth Max Transmission Power: < +10dBm

## Radio Frequency Interface Requirements – Related to European installation

Note: This equipment has been tested and found to comply with the limits for a EN 300 440 v2.1.1 receiver Category 3. These limits are designed to provide reasonable protection against harmful interference in a residential installation. This equipment is sensitive to other equipment that intentionally generates, radio frequency energy in the 5725~5875MHz that may conduce to the instability to the product. However, there is no guarantee that interference will not occur in a particular installation. If this equipment suffered from the harmful interference from another radio device to radio this can be determined by turning the respective equipment off and on, the user is encouraged to try to correct the interference by one or more of the following measures:

- Turn off the disturbance equipment
- Increase the separation between the disturbance equipment
- Consult the dealer or an experienced radio / TV technician for help



In case of damage to the wires, it has to be replaced only by the manufacturer, distributor or an expert to avoid risks.

Zur Vermeidung von Risiken müssen defekte Leitungen ausschließlich vom Hersteller, Inverkehrbringer oder Fachmann ausgetauscht werden.



Suzhou Opple Lighting Co.,Ltd.  
215200  
East Side, Fenyang Road,  
Fenhu Economic Development Zone,  
Wujiang City, Jiangsu Province,  
P.R.China

Opple Lighting BV  
Meerenakkerweg 1-07  
5652 AR Eindhoven  
The Netherlands  
service@opple.com  
www.opple.com