

# Suspended Panel Riga

Item Code	CCT	kg
542004095200	3000K/3500K/4000K	3.6kg
542004095300	3000K/3500K/4000K	3.5kg

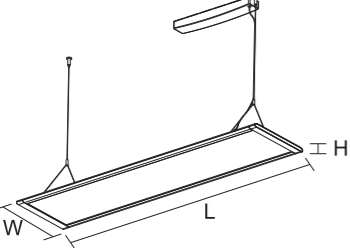

Model	L (mm)	W (mm)	H (mm)	Rated Voltage	Frequency	Power Factor	Rated Power
LED PL-R-P RE295-34/40W-DALI	1200	300	16.5	220-240V~	50/60Hz	0.9	34/40W
LED PL-R-P RE295-34/40W-BLE2	1200	300	16.5	220-240V~	50/60Hz	0.9	34/40W



## Light Source

	Product Description	N	Energy Label	Light source code	QR Code
542004095200	LED Riga-P Re295-34/40W-DALI-830/840	2		LS078001532	
542004095300	LED Riga-P Re295-34/40W-BLE2-830/840				

\* This product contains a light source of energy efficiency class (D).

## Installation

①

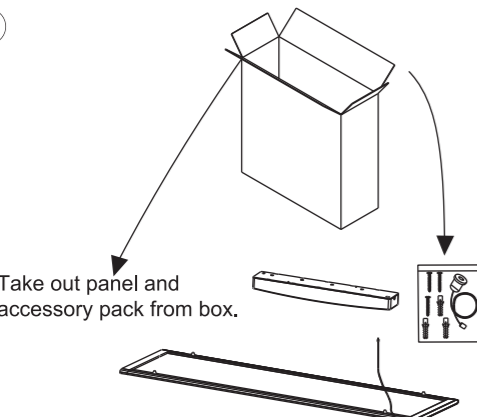

Take out panel and accessory pack from box.

②

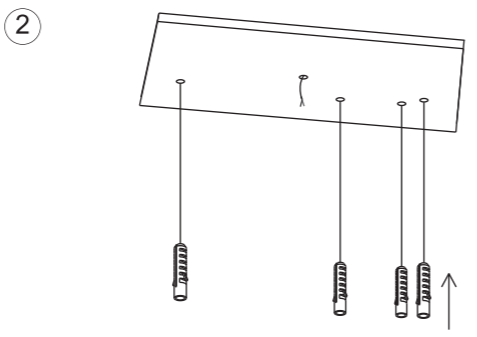

Install dowels into the ceiling.

③

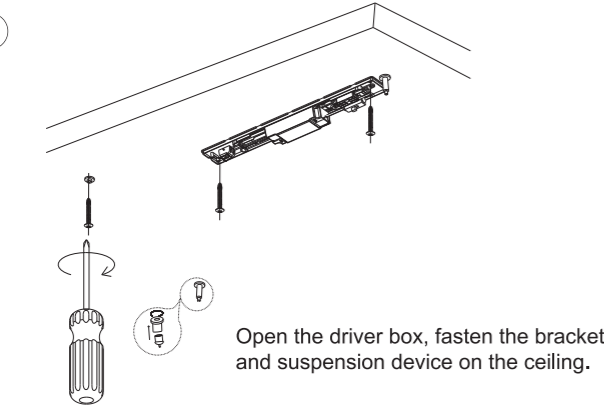

Open the driver box, fasten the bracket and suspension device on the ceiling.

④

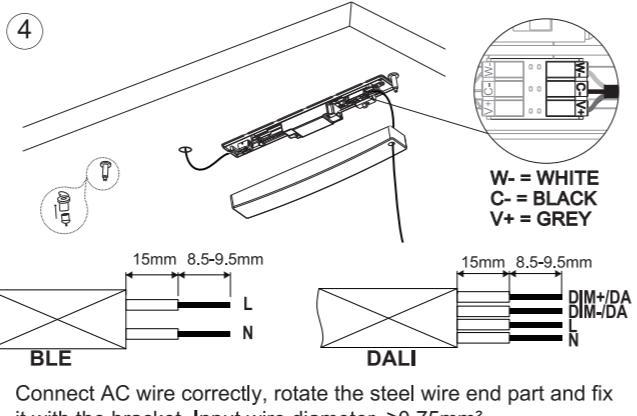

W- = WHITE  
C- = BLACK  
V+ = GREY

Connect AC wire correctly, rotate the steel wire end part and fix it with the bracket. Input wire diameter  $\geq 0.75\text{mm}^2$

⑤

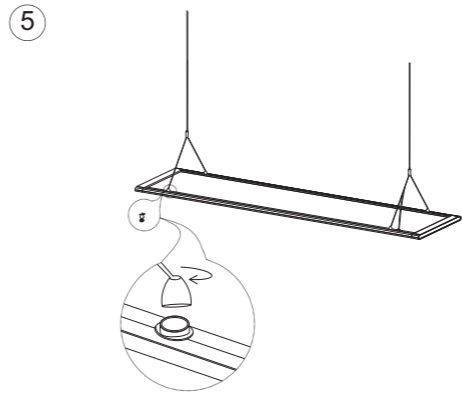

Connect two "Y" shape steel wire with panel.

⑥

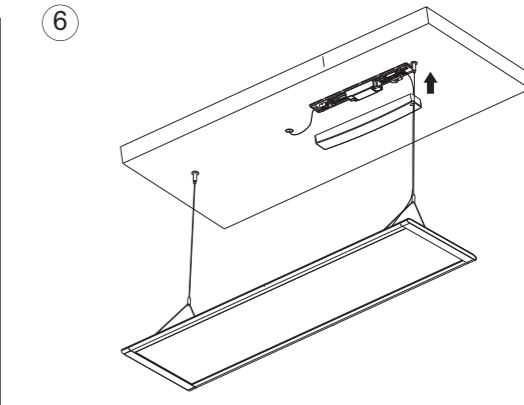

Fix the steel wire into the suspension device.

⑦

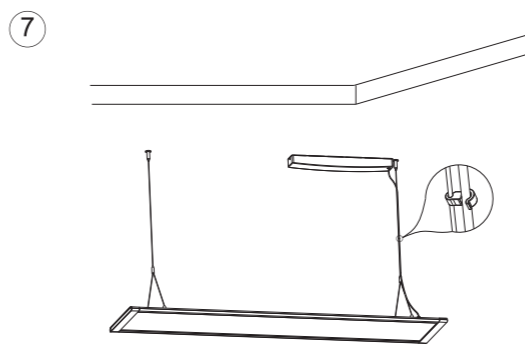

Adjust a suitable length for steel wire, fix the wires with cable clip.

⑧

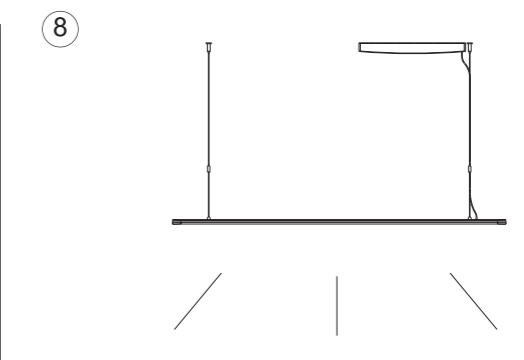

Complete.

## Power Selection

LED Driver

0.75

○ DIM+/DA

○ DIM-/DA

○ ON

○ NC

○ L

○ LED+

○ LED-

0.5-0.75

ON/OFF

Power Selection

Number	Output Current	Power	
1	900mA	34W	default
2	1050mA	40W	

**WARNING:**

1. Switch off before installation.
2. Switch on only after complete installation and examination of the circuit.
3. Professional electrician for installation and maintenance only.

Bluetooth Operating frequency: 2402-2480MHz  
Bluetooth Max. Transmission Power: 10dBm.

- Caution: Any operation on LED module is forbidden while power-on. Zur Vermeidung von Risiken müssen defekte Leitungen ausschließlich vom Hersteller, Inverkehrbringer oder Fachmann ausgetauscht werden. Achtung: In betrieb ist keine Arbeit am LED-Modul erlaubt.
- For non-user replaceable light sources: The light source contained in this luminaire shall only be replaced by the manufacturer or his service agent or a similar qualified person. Für nicht vom Benutzer austauschbare Lichtquellen: Die in dieser Leuchte enthaltene Lichtquelle darf nur vom Hersteller oder seinem Servicevertreter oder einer ähnlich qualifizierten Person ausgetauscht werden.

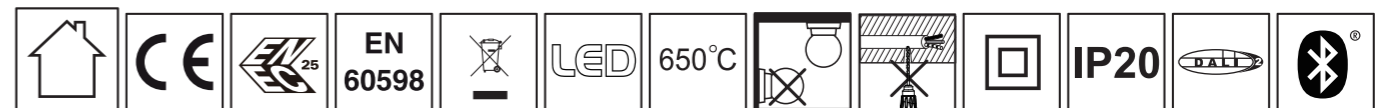

2 Data subject to change  
Les données sont sujettes à modifications  
Änderungen vorbehalten

Opplé Lighting Electronic (Zhongshan) Co.,Ltd.  
Building A, No.275 Dongan Bei Road,  
Haizhou District, Guzhen Town, Zhongshan City,  
Guangdong Province, P.R.China

Opplé Lighting B.V. Meerenakkerweg 1-07  
5652 AR Eindhoven The Netherlands  
service@opple.com  
www.opple.com

# OPPLE Smart Lighting System Quick Start Guide

# OPPLE

For the Smart Classic Manual go to  
[opple.eu/en/smart-manual](http://opple.eu/en/smart-manual)

Or scan the QR code



Smart manual

<b>OPPLE</b> LIGHTING.	<b>IT</b>	<b>OPPLE</b> LIGHTING.	<b>ES</b>
<b>OPPLE Smart Lighting Classic System</b> Installa in 5 semplici passaggi		<b>OPPLE Smart Lighting Classic System</b> Instalar en 5 pasos sencillos	
<b>PASSO 1</b>  SCARICARE E FARE IL LOGIN	<b>PASSO 2</b>  INSTALLARE I DISPOSITIVI INTELLIGENTI	<b>PASSO 3</b>  CREARE IL PROGETTO / SELEZIONARE GLI SPAZI	<b>PASO 1</b>  DESCARGAR E INICIAR SESIÓN
<b>PASSO 4</b>  SELEZIONARE GLI APPARECCHI	<b>PASSO 5</b>  CREARE SCENE E AUTOMAZIONI	<b>FINITO</b>  PRONTO AD ACCENDERE LA LUCE	<b>PASO 2</b>  INSTALAR DISPOSITIVOS INTELIGENTES
<b>PASO 3</b>  SELECCIONAR LUMINARIAS	<b>PASO 4</b>  CREAR ESCENAS Y AUTOMATIZACIONES	<b>TERMINADO</b>  LISTO ENCIÉNDELO	
<b>OPPLE</b> LIGHTING.	<b>PT</b>	<b>OPPLE</b> LIGHTING.	<b>FI</b>
<b>OPPLE Smart Lighting Classic System</b> Instale em 5 etapas fáceis		<b>OPPLE Smart Lighting Classic System</b> Asenna 5 helpolla askeleella	
<b>PASSO 1</b>  DESCARREGAR E INICIAR SESSÃO	<b>PASSO 2</b>  INSTALAR DISPOSITIVOS INTELIGENTES	<b>PASSO 3</b>  CRIAR PROJECTO / SELECCIONAR ESPAÇOS	<b>VAIHE 1</b>  LATAA & KIRJAUDU SISÄÄN
<b>PASSO 4</b>  SELECCIONE LUMINAIRES	<b>PASSO 5</b>  CRIAR CENAS & AUTOMATIZAÇÕES	<b>CONCLUÍDO</b>  PRONTO ILUMINÁ-LO	<b>VAIHE 2</b>  ASENNA ÄLYLAITTEET
			<b>VAIHE 3</b>  LUO PROJEKTI / VALITSE TILAT
			<b>VAIHE 4</b>  VALITSE VALAISIMET
			<b>VAIHE 5</b>  LUO KOHTAUKSIA & AUTOMAATIOITA
			<b>VALMIS</b>  VALMIS VALO SYTTY

<b>OPPLE</b> LIGHTING.	<b>EN</b>	<b>OPPLE</b> LIGHTING.	<b>NL</b>
<b>OPPLE Smart Lighting Classic System</b> Install in 5 easy steps		<b>OPPLE Smart Lighting Classic System</b> Installatie in 5 eenvoudige stappen	
<b>STEP 1</b>  DOWNLOAD & LOGIN	<b>STEP 2</b>  INSTALL SMART DEVICES	<b>STEP 3</b>  CREATE PROJECT / SELECT SPACES	<b>STAP 1</b>  DOWNLOADEN EN AANMELDEN
<b>STEP 4</b>  SELECT LUMINAIRES	<b>STEP 5</b>  CREATE SCENES & AUTOMATIONS	<b>FINISHED</b>  READY LIGHT IT UP	<b>STAP 2</b>  SMART APPARATEN INSTALLEREN
			<b>STAP 3</b>  CREËER PROJECT / SELECTEER RUIMTES
			<b>STAP 4</b>  SELECTEER ARMATUREN
			<b>STAP 5</b>  SCÈNES & AUTOMATISERINGEN MAKEN
			<b>EINDE</b>  KLAAR LICHT AAN
<b>OPPLE</b> LIGHTING.	<b>DE</b>	<b>OPPLE</b> LIGHTING.	<b>FR</b>
<b>OPPLE Smart Lighting Classic System</b> In 5 einfachen Schritten installieren		<b>OPPLE Smart Lighting Classic System</b> Installer en 5 étapes faciles	
<b>SCHRITT 1</b>  HERUNTERLADEN & ANMELDEN	<b>SCHRITT 2</b>  SMART DEVICES INSTALLIEREN	<b>SCHRITT 3</b>  PROJEKT ERSTELLEN / RÄUME AUSWÄHLEN	<b>ÉTAPE 1</b>  TÉLÉCHARGEMENT ET CONNEXION
<b>SCHRITT 4</b>  BELEUCHTUNGSKÖRPER AUSWÄHLEN	<b>SCHRITT 5</b>  SZENEN & AUTOMATISIERUNGEN ERSTELLEN	<b>FERTIG</b>  FERTIG LICHT AN	<b>ÉTAPE 2</b>  INSTALLER LES DISPOSITIFS INTELLIGENTS
			<b>ÉTAPE 3</b>  CRÉER UN PROJET / SÉLECTIONNER LES ESPACES
			<b>ÉTAPE 4</b>  SÉLECTIONNER LES LUMINAIRES
			<b>ÉTAPE 5</b>  CRÉER DES SCÈNES ET DES AUTOMATISMES
			<b>TERMINÉ</b>  PRÊT ALLUMEZ-LE