

# LED Waterproof

# OPPLE

Version date 09-08-2022  
www.opple.com

Item Code	CCT
LED WP-B2 L1200-36W-840	4000K
LED WP-B2 L1200-36W-865	6500K
LED WP-B2 L1500-50W-840	4000K
LED WP-B2 L1500-50W-865	6500K

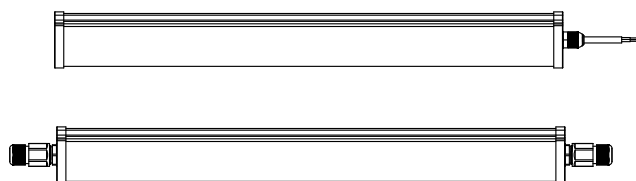
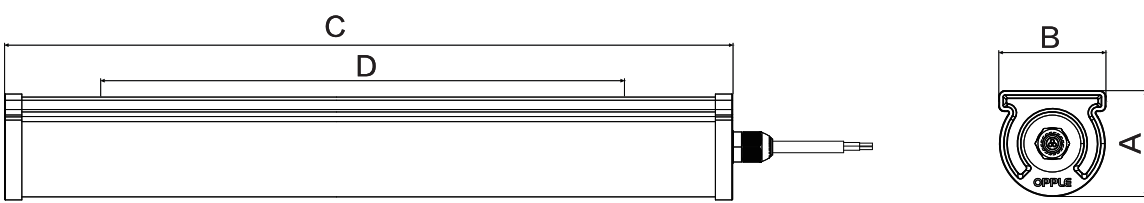



	A(mm)	B(mm)	C(mm)	D(mm)	Rated Voltage	Frequency
LED WP-B2 L1200	62	63	1200	900	220-240V~	50/60Hz
LED WP-B2 L1500	62	63	1500	1200	220-240V~	50/60Hz

Product Code	Product Description	N	Light source code	QR Code	Energy Label
71100004500	LEDWaterproof-B2 L1200-36W-865	1	LS069003619		
71100004600	LEDWaterproof-B2 L1200-36W-840	1	LS069003615		
71100004900	LEDWaterproof-B2 L1500-50W-865	1	LS069005019		
71100005000	LEDWaterproof-B2 L1500-50W-840	1	LS069005015		

\* This product contains a light source of energy efficiency class (D).

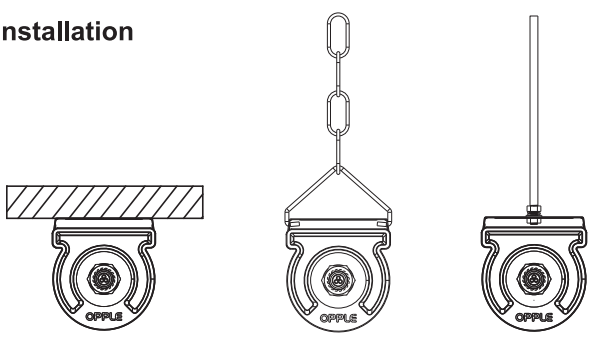
### Installation



Surface Mounting      Suspension Mounting      Pole Mounting

①

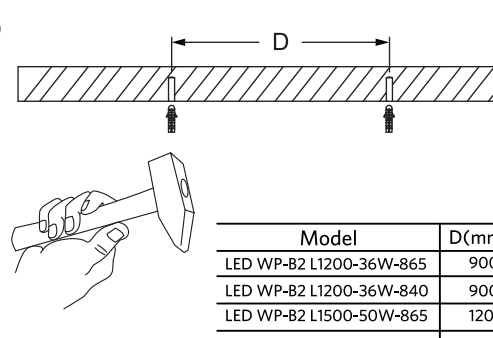

Model	D(mm)
LED WP-B2 L1200-36W-865	900
LED WP-B2 L1200-36W-840	900
LED WP-B2 L1500-50W-865	1200
LED WP-B2 L1500-50W-840	1200

② Surface Mounting

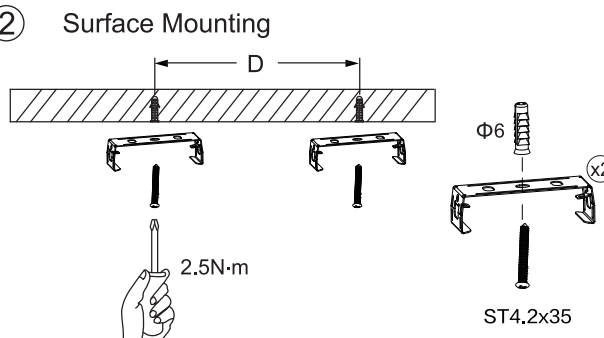

2.5N·m      Φ6      ST4.2x35      x2

③

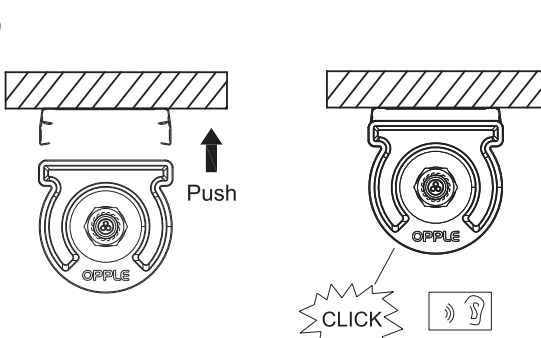

Push      CLICK

④

### Suspension Mounting

### Pole Mounting

Picture	Code	Specification
	H	M5 (External thread length > 20mm)
	I	M5
	J	M5
	K	M5

Remark: Not included;  
Please purchase separately

### Wire Through

The external cables at both ends are threaded into their respective junction boxes, and the nuts of the junction box are locked with tools

	8	N (Blue)
	8	Earth (Yellow-Green)
	8	L (Brown)

MAX: 3 × 1.5mm<sup>2</sup>

250054023001



Caution: Any operation on LED module is forbidden while power-on.  
Zur Vermeidung von Risiken müssen defekte Leitungen ausschließlich vom Hersteller, Inverkehrbringer oder Fachmann ausgetauscht werden.  
Achtung: In Betrieb ist keine Arbeit am LED-Modul erlaubt.



For non-user replaceable light sources:  
The light source contained in this luminaire shall only be replaced by the manufacturer or his service agent or a similar qualified person.  
Das Leuchtmittel dieser Leuchte ist nicht austauschbar. Wenn das Leuchtmittel das Ende seiner Lebensdauer erreicht hat, muss die gesamte Leuchte ersetzt werden.



For use in environments where normal non-conductive/conductive dust accumulation may be expected, not for use in environments with expected high/unusual dust accumulation.

