

LED Waterproof Batten

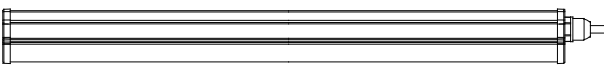

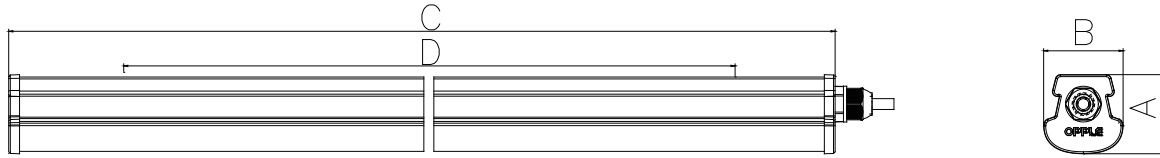



OPPLE

Version date 02-03-2024
www.opple.com

Item Code	CCT
LEDWaterproof-Batten L06-18W-840	4000K
LEDWaterproof-Batten L12-36W-840	4000K
LEDWaterproof-Batten L15-50W-840	4000K





	A (mm)	B (mm)	C (mm)	D (mm)	Rated Voltage	Frequency	Rated Power
WP-Batten L06 18W	48	48	598	400	220-240V~	50/60Hz	18W
WP-Batten L12 36W	48	48	1198	900	220-240V~	50/60Hz	36W
WP-Batten L15 50W	48	48	1498	1200	220-240V~	50/60Hz	50W

Product Code	Product Description	N	Light source code	QR Code	Energy Label
531000022800	LEDWaterproof-Batten L06-18W-840	1	403100321000		
531000022900	LEDWaterproof-Batten L12-36W-840	1	403100322000		
531000023000	LEDWaterproof-Batten L15-50W-840	1	403100323000		

* This product contains a light source of energy efficiency class (E).

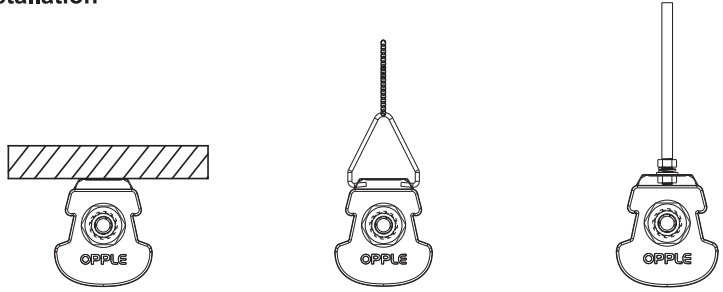
Installation



Surface Mounting Suspension Mounting Pole Mounting

1

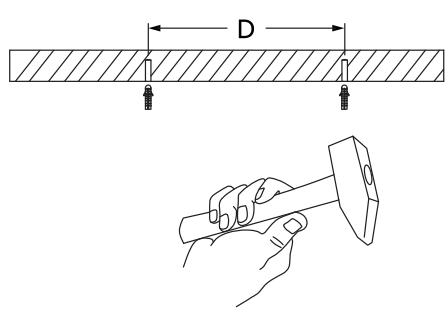

2

Surface Mounting

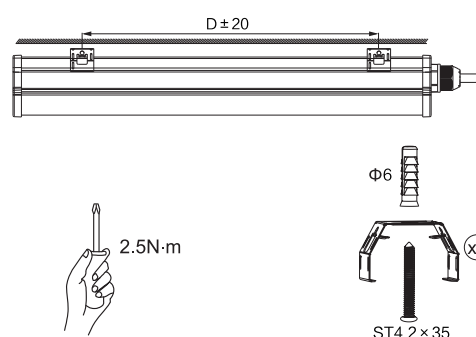

$D \pm 20$

$\Phi 6$

2.5N·m

ST4.2 x 35 (x2)

Suspension Mounting

Pole Mounting

Picture	Code	Specification
	H	M5 (External thread length > 20mm)
	I	M5
	J	M5
	K	M5

Remark: Not included;
Please purchase separately

3

Waterproof Connection Box*

*Additional IP65 waterproof connection box (including in packaging) is necessary for power connection to ensure the waterproof performance and safety.

4

CLICK



Caution: Any operation on LED module is forbidden while power-on.
 Zur Vermeidung von Risiken müssen defekte Leitungen ausschließlich vom Hersteller, Inverkehrbringer oder Fachmann ausgetauscht werden.
 Achtung: In Betrieb ist keine Arbeit am LED-Modul erlaubt.

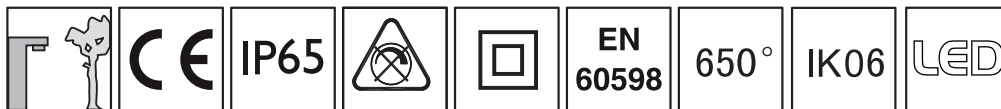

Opplé Lighting B.V.
 Meerenakkerweg 1-07 | 5652 AR Eindhoven
 The Netherlands
 service@opple.com

OPPLE Lighting Co., Ltd.
 Room 411, Building 1 No. 6111, Longdong Avenue,
 Pudong New District, Shanghai City 201201, P.R.China
 www.opple.com