

Lo-Carbon PureAir Cleanse

- Continuously running fan with sleek circular design
- Suitable for PAS 2035 energy efficiency retrofits
- Near silent operation independently tested
- IPX5 rated, wall and ceiling mounted Zones 1, 2 and 3
- Low ceiling void - 56mm (100mm spigot)
- Easy to commission, fully adjustable variable control platform
- Intelligent Air Quality sensor, humidistat and timer model option with proportional increase
- Meets UBA air quality standard
- Comfort control option
- 7 year warranty
- Recognised in SAP PCDB



Lo-Carbon PureAir Cleanse

Increased whole ventilation rates, should not mean increased noise levels. The Vent-Axia Lo-Carbon PureAir Cleanse fan, provides adequate ventilation whilst minimising noise.

The air quality sensor detects and measures chemical pollutants, specifically total volatile organic compounds (VOCs), which are commonly found in enclosed or occupied spaces. Meeting the UBA air quality standard, once unpleasant odours are detected, a proportionate boost function is triggered to increase extraction rate and help clear the air of unwanted pollutants faster.

The fan is designed in line with the Approved Document F 2021 Building Regulations, meeting the increased whole house ventilation rates.

Table 1.3 - Minimum whole dwelling ventilation rates determined by the number of bedrooms.

No. of bedrooms	2013 Edition	2021 Edition	Increase
1	13l/s	19l/s	46%
2	17l/s	25l/s	47%
3	21l/s	31l/s	47%
4	25l/s	37l/s	48%

The minimum whole dwelling ventilation rate for the supply air should meet the higher of the two following result:

- A minimum rate of 0.3l/s per m² of internal floors area
- A minimum rate determined by the number of bedrooms, as per Table 1.3

Nuisance tripping has also been minimised within the fan logic. The integral humidity sensor versions have functionality that allows for proportional speed increase up to 85% relative humidity (RH) before enabling Boost.

The Lo-Carbon PureAir Cleanse is complete with IPX5 rating, allowing flexible installation within Zone 1, 2 and 3.

A back pressure detection system option is available, to Boost if the system pressure increases momentarily due to external wind conditions. A silent mixed flow impeller means the Lo-Carbon PureAir Cleanse can meet the requirements of many domestic installations without the need to use a traditional centrifugal fan.

A brand new control platform also provides fully adjustable airflow, meaning wholehouse rates can be achieved easily using fewer fans.

Comfort Control Option

Designed to offer a more relaxing environment to the homeowner, the Lo-Carbon PureAir Cleanse features a delayed start. This patented comfort control option allows the homeowner to enjoy a quiet, peaceful bathroom for up to 20 minutes before the Boost activates. Furthermore, if the light switch turns On and Off within three minutes, the Boost will not activate. No more disturbing the family if the bathroom light is turned on during the night.

Near Silent Operation

The fan has been designed to be as discreet as possible for homeowners, with independently tested sound levels as low as 7.4dB(A).

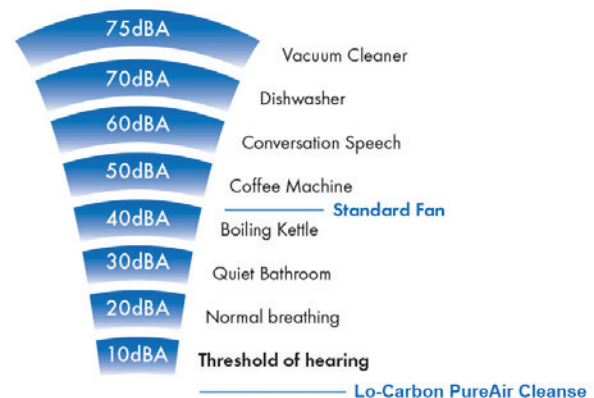

Model

Lo-Carbon PureAir Cleanse

The fan runs continuously to extract air from kitchens, utility rooms, bathrooms, and toilets. It features a built-in speed control dial, allowing users to adjust airflow to suit specific installation needs. Every model includes back-pressure detection and a quiet comfort mode as standard. The HT & HT-IAQ variant include a digital humidity/timer sensor with preset thresholds with rapid rise detection; the HT-IAQ sensor goes further by measuring chemical pollutants. Whenever humidity or pollutants climb, the fan automatically boosts its speed to quickly clear moisture and airborne contaminants from your home.

Variable speed setting

Model	Stock Ref
Lo-Carbon PureAir Cleanse 100	414942
Lo-Carbon PureAir Cleanse 100 HT	416841
Lo-Carbon PureAir Cleanse 100 HT-IAQ	414943

Accessories

Model	Stock Ref
Wall Kit White 100mm	254102
Wall Kit Brown 100mm	254100

Consultant Specification

The de-centralised mechanical extract ventilation unit shall be the Lo-Carbon PureAir Cleanse as manufactured by Vent-Axia, exact unit sizing and specification shall be in accordance with the particular specification.

This range features IPX5-rated, 100mm units designed to comply with Building Regulations. Engineered for efficient air extraction from wet rooms, including kitchens and utility spaces. It supports installation via rigid or flexible ducting, as well as through-wall applications, minimising the number of fans required. Each unit comes with a 7 year warranty.

The Lo-Carbon PureAir Cleanse should have variable speed settings of 5-26 l/s achieving a minimum noise level of 7.4dB(A) at 3 metres. All sound pressure levels are quoted at hemispherical measurements. All units shall be and independently third-party tested at the Sound Research Laboratory (SRL), tested to BS EN 13141-6.

The unit shall comprise a single high efficiency EC/DC motor to deliver specific fan powers as low as 0.08 W/l/s.

The controls for the Lo-Carbon PureAir Cleanse unit shall provide fully adjustable, continuous whole house ventilation rates. On the HT-IAQ model with integrated humidity and air quality sensors, both sensors operate fully automatically with no manual adjustments. When humidity climbs, the fan boosts to a speed of 50% above the trickle rate, and if indoor pollutants are detected, the air quality sensor will raise the fan speed to clear the air or via LS input.

The fan shall be compatible with low ceiling voids and have a spigot length of 56mm (100mm). The fan shall have the nuisance tripping prevention option called Comfort Control, which stops the fan from engaging Boost when the LS input is engaged for less than three minutes.

The unit shall be able to be commissioned as a continuous running fan according to the Building Regulations compliant design.

Dimensions (mm)

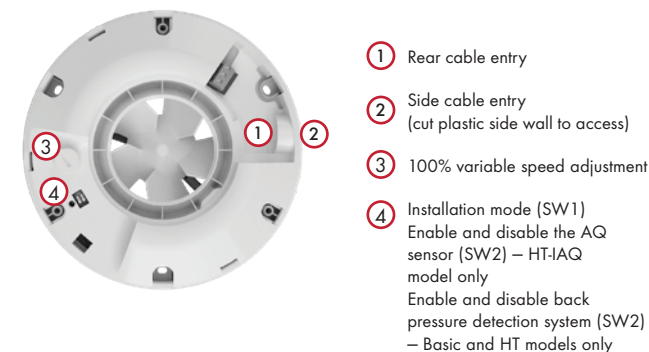
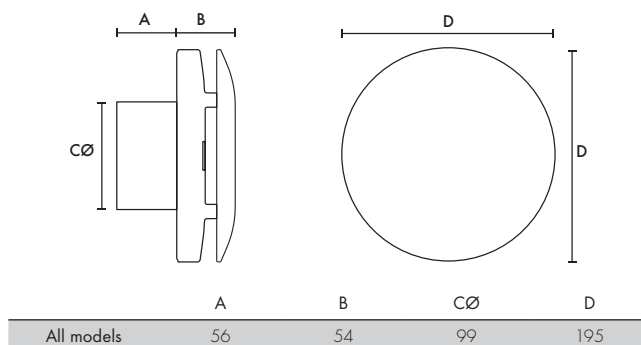

Performance Guide

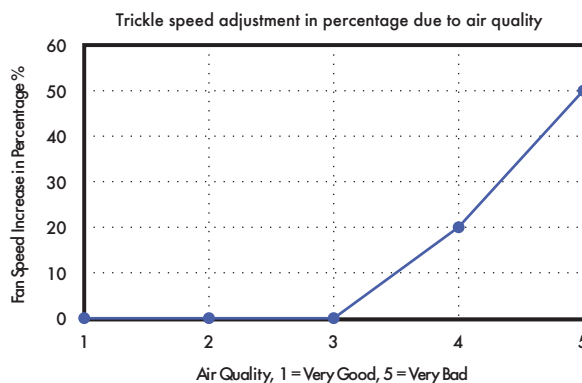
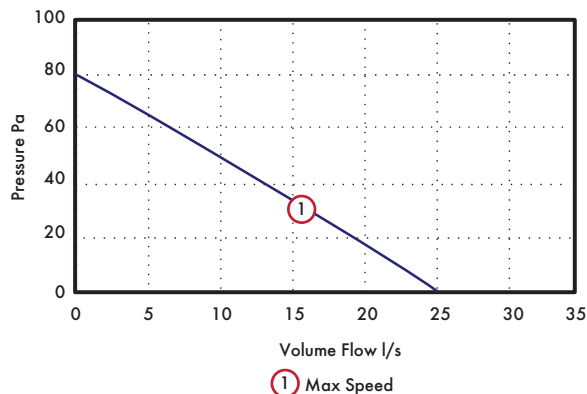

Sound

Speed	dB(A)
Min	7.4
Max	34.3