

# Lo-Carbon Revive

CONTINUOUS & INTERMITTENT EXTRACT FILTERLESS FAN

Installation and Wiring Instructions

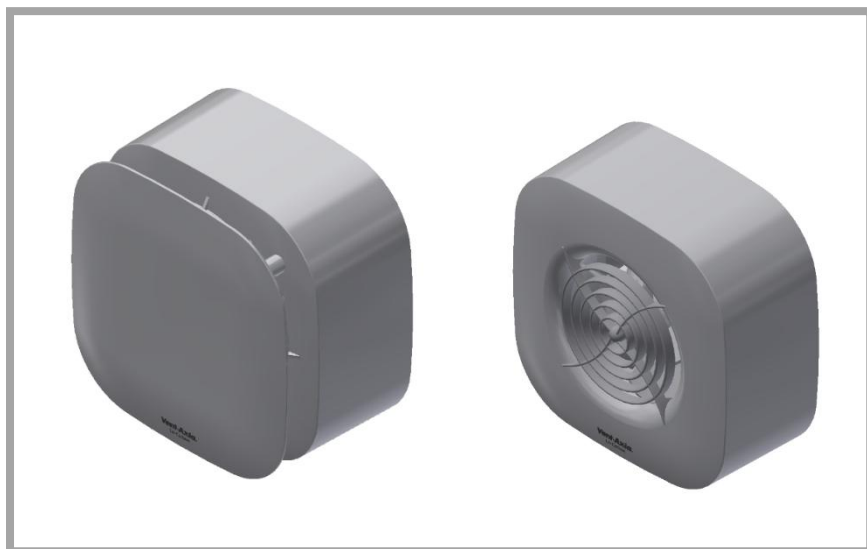

## Stock Ref. N°

Revive 7	473848B
Revive 7 SELV	473849B
Revive 5	473850B
Revive 5 SELV	473851B
Revive	473852B
Revive SELV	473853B
Revive 7 – Switchee-enabled	416556
Revive 7 SELV – Switchee-enabled	416557

220-240V~50Hz

IPX4  
IPX7 – SELV models

# Vent-Axia®

PLEASE READ INSTRUCTIONS IN CONJUNCTION WITH ILLUSTRATIONS.  
PLEASE SAVE THESE INSTRUCTIONS.

FOR SWITCHEE ENABLED DEVICES PLEASE REFER TO THE LAST  
PAGE OF THIS INSTRUCTION.

UK  
CA  
CE

## Installation and Wiring Instructions for the Revive Range of Extractor Fans.



### **IMPORTANT: READ THESE INSTRUCTIONS BEFORE COMMENCING THE INSTALLATION**

DO NOT install this product in areas where the following may be present or occur:

- Excessive oil or a grease laden atmosphere.
- Corrosive or flammable gases, liquids or vapours.
- Ambient temperatures higher than 40°C or less than -5°C.
- Possible obstructions which would hinder the access or removal of the Fan.

### **SAFETY AND GUIDANCE NOTES**

- A.** All wiring to be in accordance with the current I.E.T. Regulations, or the appropriate standards of your country and **MUST** be installed by a suitably qualified person.
- B.** The Fan should be provided with a local isolator switch capable of disconnecting all poles, having a contact separation of at least 3mm.
- C.** Ensure that the mains supply (Voltage, Frequency, and Phase) complies with the rating label.
- D.** The Fan should only be used in conjunction with the appropriate Vent-Axia products.
- E.** The fan should only be used in conjunction with fixed wiring.
- F.** When the Fan is used to remove air from a room containing a fuel-burning appliance, ensure that the air replacement is adequate for both the fan and the fuel-burning appliance.
- G.** The Fan should not be used where it is liable to be subject to direct water spray for prolonged periods of time.
- H.** Where ducted Fans are used to handle moisture-laden air, a condensation trap should be fitted. Horizontal ducts should be arranged to slope slightly downwards away from the Fan.
- I.** This appliance is not intended for use by persons (including children) with reduced physical, sensory or mental capabilities, or lack of experience and

knowledge, unless they have been given supervision or instruction concerning use of the appliance by a person responsible for their safety.

**J.** Young children should be supervised to ensure that they do not play with the appliance.

**K.** Cleaning and user maintenance shall not be made by children.

## **DESCRIPTION**

The Revive fan is a continuously running or intermittent extract fan for kitchens, utility rooms, bathrooms and toilets.

The incorporated LED display allows the installer to configure the fan to suit its installation. The display is also used to display the day logger and power run meter. (Not available on Revive & Revive SELV models) The fan can be wall, window or panel/ceiling mounted.

## **ACCESSORIES** (not supplied)

A range of white (stock ref. 254102) or brown (stock ref. 254100) 100mm wall kits are available for installing into most walls using telescopic liners supplied. A window fitting kit (stock ref. 407927) and a ceiling kit (stock ref. 407928) are available. A 150mm conversion kit (stock ref. 408680) is available for use when replacing a 150mm fan. A decoration frame (stock ref. 474041) is also available for use when replacing a fan with a larger footprint.

## **A. INSTALLATION**

### **SITING THE TRANSFORMER (SELV Models only)**

1. The transformer must not be installed in a shower cubicle or enclosure. It must be sited away from direct sources of water spray and out of reach (1.5m) of a person using a fixed bath or shower.
2. Site away from direct sources of heat. Ambient temperature range 0 °C to 40°C. Do not site in an area containing excessive levels of grease.
3. Decide where to site the transformer and fan and work out the required cable runs.

### **PANEL/CEILING/ INTERIOR WALL MOUNTING**

1. Cut a 105mm diameter hole.
2. Loosen the screw at the bottom of the grille, and then remove the grille by carefully pulling away from the housing.
3. Mark the screw centres through the holes in the fan back plate. Drill, plug and screw into position. Attach ducting as required for the installation.
4. Wire the fan as described in Section B-Wiring. Adjust any settings as required (see Section C-Setup).
5. After installation, ensure impeller rotates freely.
6. Replace the grille and tighten the retaining screw.

## EXTERIOR WALL MOUNTING

1. For wall mounting cut a 117mm diameter hole through the wall and insert the wall sleeve. Slope the sleeve slightly downwards away from the fan. Where necessary cut to length and cement both ends into position flush with the wall faces.
2. Fix exterior grille into position with the louvres positioned downwards.
3. Loosen the screw at the bottom of the grille, and then remove the grille by carefully pulling away from the housing.
4. Mark the screw centres through the holes in the fan back plate. Drill, plug and screw into position.
5. Wire the fan as described in Section B-Wiring. Adjust any settings as required (see Section C-Setup).
6. After installation, ensure impeller rotates freely.
7. Replace the grille and tighten the retaining screw.

## WINDOW MOUNTING

For window mounting refer to the instructions provided with the kit.

### B. WIRING.



**WARNING: THE FAN AND ANCILLARY CONTROL EQUIPMENT MUST BE ISOLATED FROM THE POWER SUPPLY DURING INSTALLATION OR MAINTENANCE.**

### IMPORTANT

- The cross - sectional area of supply cord used should be ranged from 1 -1.5mm<sup>2</sup>.
- The extraction fan or transformer (SELV models) is suitable for connection to 220-240V 50Hz supply.
- **The Transformer (SELV models only) MUST** be surface mounted to allow air to freely circulate around the unit. When installed in a loft void it **MUST NOT** be enclosed or covered with insulation.
- The fan is a class II double insulated product and **MUST NOT** be earthed.

1. Select and follow the appropriate wiring diagram. (Fig. 1, 2, 3, OR 4, 5, 6)
2. Check all connections have been made correctly and ensure all terminal connections and supply wires are securely fastened.
3. Ensure the impeller rotates and is free from obstructions.

### C. SETUP

#### Accessing the commissioning menu

To configure the fan first remove the grille. With the grille removed the control board is visible (Fig.7). Do NOT isolate the fan from the power supply as configuration requires power to the fan; removing the grille will automatically stop the impeller from spinning.

Once the fan has been commissioned, please write the installation date in the box on the label provided.

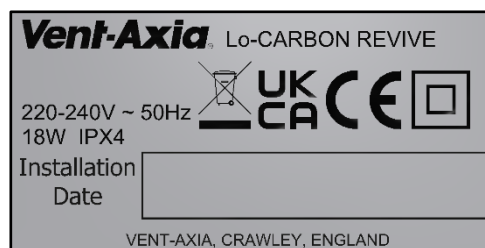

### IMPORTANT



**Do NOT** attempt to remove the circuit board cover (Fig.7). This covers the high voltage power supply, preventing the risk of an electric shock.

With the cover removed the LED display will show the commissioning menu. There are 3 buttons located below the display; these are used to control the setup process:

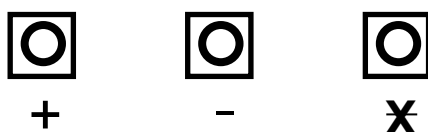

The + button is used to increase the value of a setting, the – button is used to reduce the value of a setting and the X (Mode) button moves to the next setting.

## Commissioning menu structure

Display text	Installation Option	Selections		Default
rot / ʎOJ	Rotate display*	ʎOJ = Display rotated	rot = Display Normal	Default
l-n or l-y	Intermittent Yes or No	l-n = No	l-y = Yes	See Model
t09	Trickle mode	t06 to t16 – 6 to 16 l/s		t09
b-n	Kitchen or Bathroom mode	b-n = Kitchen mode	b-y = Bathroom mode	Kitchen
F-0	Fan Control Mode	F-0 = wall/window mode	F-1 = Ducted mode	Wall/Window
b15	Boost time	b01 to b30 – 1 to 30 minutes		15 minutes
h60	Humidity level trigger	h50 to h90 - 50% to 90% relative humidity		75% RH
c-n	Comfort mode	c-n = normal boost operation	c-y = comfort mode	No
unl	Enable / disable lock code	loc - lock code enabled	unl - lock code disabled (unlocked)	unl
- - -	Menu lock code	+ / - selects current digit, X moves to next digit Set between 0 - F		10c

\* This setting rotates the display only; the buttons retain their original function. For example; the mode button is on the right when in normal rotation and on the left when the screen is rotated and looking at the fan so the display is correctly orientated.

Advanced/Engineer Menu is accessed by holding - & x for 5 seconds from the standard menu

Display text	Installation Option	Selections		Default
A - y	RH Ambient Response	A - y = On	A - n = Off	A - y
r-y	RH Rapid Rise	r - y = On	r - n = Off	r - y

The table shows the settings available to commission the fan. They appear in this order. The available options and default position for each setting is also shown.

## Settings

Mode	Trickle	Boost 1	Boost 2	Boost time
Kitchen	6-16 l/s	30 l/s	60 l/s	1-30 minutes
Bathroom	6-16 l/s	18 l/s	30 l/s	1-30 minutes



## Installation selection

There are four different installation type settings, kitchen or bathroom and ducted or window/wall. The difference between bathroom and kitchen mode is shown above, the boost speeds are higher for kitchen applications. If the fan is installed in a ducted setup changing the fan to ducted mode will compensate for the reduced airflow due to the higher pressure of the system. During commissioning select the relevant setting for your installation.

## Boost time

The boost setting allows the boost timer to be adjusted from 1-30 minutes, the default is 15 minutes. The LS (Live Switch) and Pullcord can activate the boost.



b- 15 >  > b- 16 >  > b- 17 >  > b- 18

Up button pressed to change boost time from 15 to 18 minutes

## Pull Cord Function

Pull → Boost 1 → Pull → Boost 2 → Pull → Trickle

Pulling the pull-cord will activate boost 1, a second pull will enter boost 2 and a third pull will cancel the boost, returning the fan to trickle speed. The pull-cord can be used to cancel an LS activated boost, if the fan is in an LS activated boost pulling the pull-cord will first enter boost a further pull will return the fan to trickle. The pullcord activates the Boost function set in the menu. After the timeout period, the fan will return to trickle speed.

## Data Logger (Revive 5 & Revive 7)

With the fan powered up; upon removing the cover the display will automatically activate. It will display the commissioning options. Holding down the Mode button for 5 seconds will open the data logger menu. Use the mode button to move the display to the next data set.

## Data Logger Menu

\* When the display is rotated the decimal point will no longer display, eg. 055 represents 5.5KWh

Display text	Description
tot run 00y 00d	Total run time in years and days
Tri run 00y 00d	Trickle speed run time in years and days
Boo run 00d 00h	Boosted run time in days and hours
rhu run 00d 00h	Humidity boosted run time in days and hours
tot EnErgy 00.0	Total Energy used displayed in KWh*
24h EnErgy 00	Energy used in last 24 hours displayed in Wh

### Data Examples

tot run 01y 237d

← Text scrolling from right to left

In this example the display is showing a total run time of 1 year and 237 days.

24h EnErgy 034

← Text scrolling from right to left

In this example the display is showing 34Wh of energy consumption in the previous 24h.

## Returning to commissioning mode

A further 5 second press of the Mode button will return the fan to the commissioning menu.

## D. SERVICING AND MAINTENANCE.



**WARNING: THE FAN AND ANCILLARY CONTROL EQUIPMENT MUST BE ISOLATED FROM THE POWER SUPPLY DURING MAINTENANCE.**

1. At intervals appropriate to the installation, the fan should be inspected and cleaned to ensure there is no build-up of dirt or other deposits.
2. Wipe the inlets and front face with a damp cloth until clean.

**The fan has sealed for life bearings, which do not require lubrication.**

## E. TROUBLESHOOTING

1. The fan continuously runs in boost:
  - a. Cause:
    - i. The room is damp or recently redecorated.
    - ii. The humidity set point is set too low.
  - b. Solution:
    - i. If the room is damp or has recently been decorated, it could take up to 2 weeks for the humidity levels to stabilise. Please leave the fan to dry out the room and after this period the fan should run normally.
    - ii. The humidity set point could be set too low. Adjust the humidity set point to a higher setting. (Section C)
2. The fan does not boost when the humidity is high:
  - a. Cause:
    - i. The humidity set point is set too high.
  - b. Solution:
    - i. Adjust the humidity set point to a lower setting. (Section C)
3. Water is dripping out of the fan when installed in a ceiling:
  - a. Cause:
    - i. This is caused by condensation forming on the inside of the ducting and dripping out of the fan inlet.
  - b. Solution:
    - i. This is normal and the fan is designed to handle condensation build up. However, a condensation trap connected immediately after the fan will help to prevent water dripping into the room.

Siting the fan.

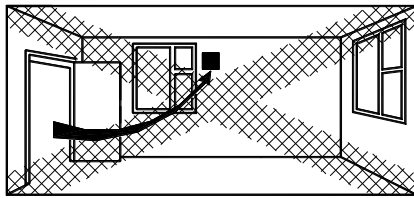

X

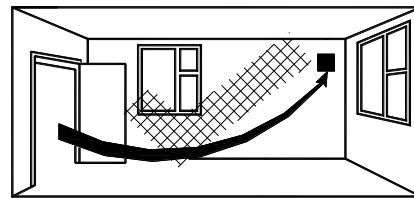

✓

Fig.1 Continuous trickle with boost via pull cord. (The fan is internally fused)

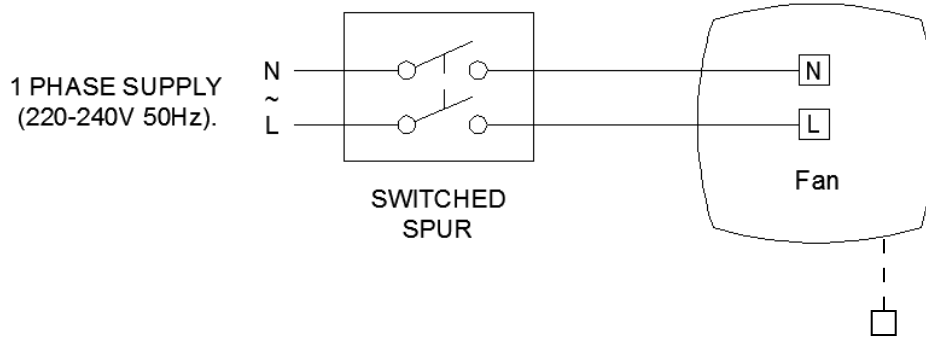

Fig.2 Continuous boost 1 with no trickle facility. (The fan is internally fused)

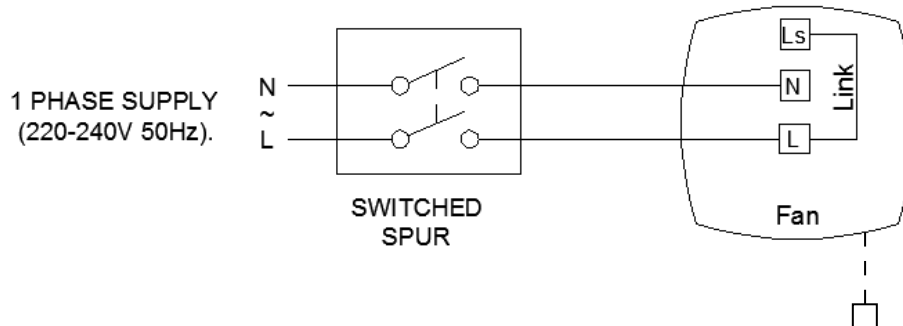

Fig.3. Continuous trickle with boost facility. (The fan is internally fused)

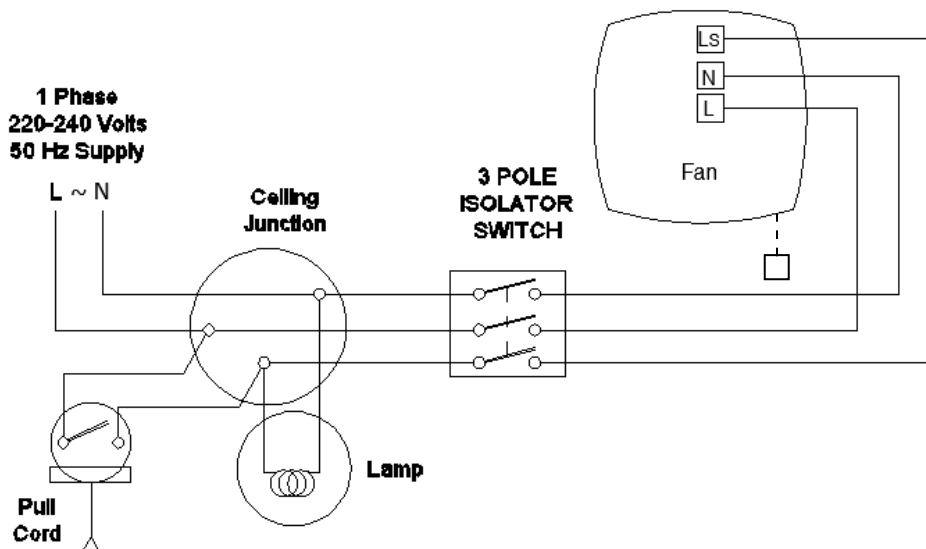

Fig.4 Continuous trickle with pull-cord boost SELV models

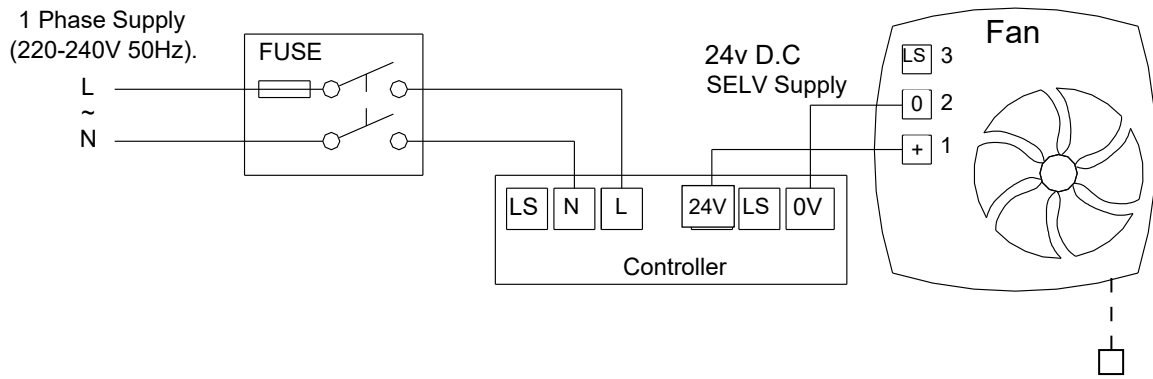

Fig.5 Continuous boost 1 with no trickle facility SELV models

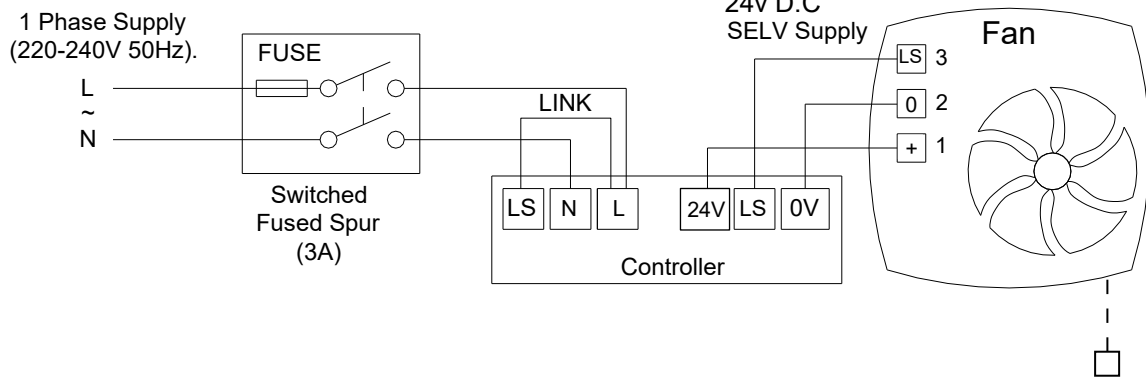

Fig.6 Continuous trickle with boost facility via LS or internal pull-cord, SELV models

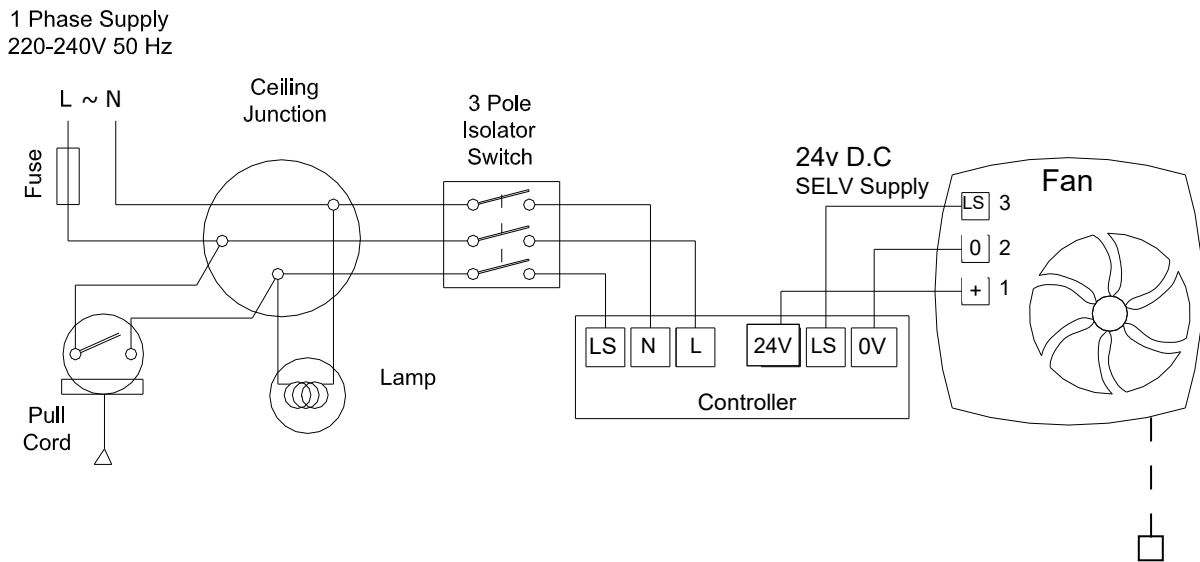

Fig.7. Removing the grille for wiring and setup

2. Pull the grille  
clear of the screw  
and lift away



**Note:** Revive 7 models; do **NOT**  
attempt to pull off the flat front cover.

1. Loosen the screw at the bottom  
of the grille

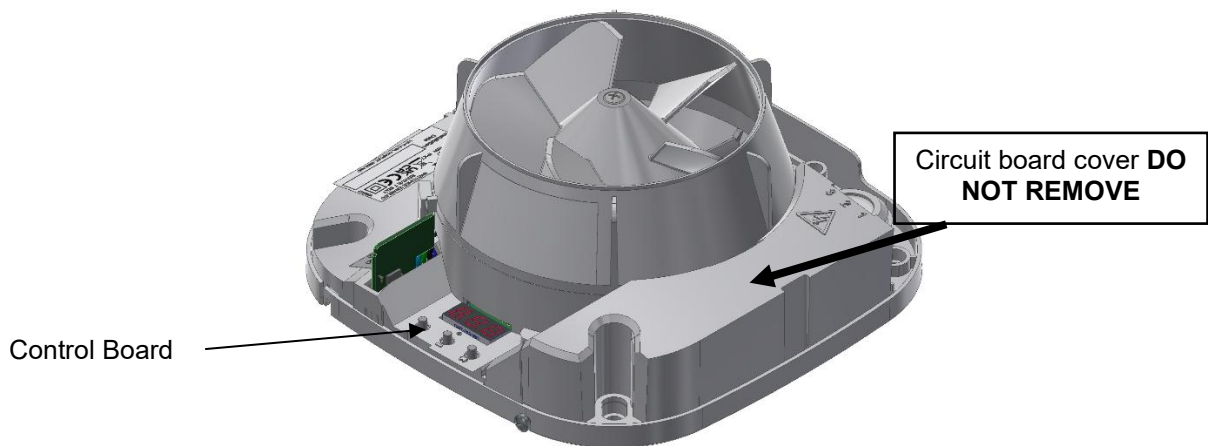

Display

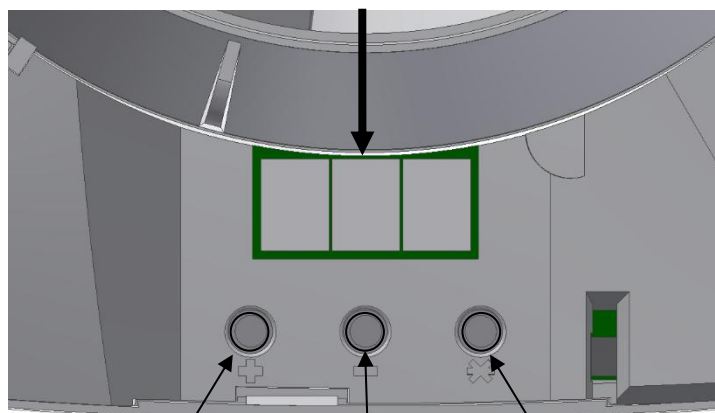

**INCREASE**  
Value

**REDUCE**  
Value

**MODE**  
Button

## Electrical Household Goods - Energy Consumption Comparison

Products	Energy Consumption	Estimated kWh per year	Estimated Yearly Running Cost
<b>Revive</b> Bathroom Setting 	Trickle 9l/s: <b>1.4W</b>	23 hours a day on trickle speed: <b>11.75kWh per year</b>	<b>£3.06</b>
	Boost 18l/s: <b>2W</b>	1 hour a day on boost speed: <b>0.73kWh per year</b>	
<b>Revive</b> Kitchen Setting 	Trickle 9l/s: <b>1.4W</b>	23 hours a day on trickle speed: <b>11.75kWh per year</b>	<b>£4.58</b>
	Boost 60l/s: <b>19W</b>	1 hour a day on boost speed: <b>6.94kWh per year</b>	
55" Smart 4K Ultra HD HDR LED TV 	Standby Power: <b>0.5W</b>	18 hours a day on standby power: <b>3.29kWh per year</b>	<b>£49.09</b>
173l Fridge Freezer 	_____	Manufacturer quotes <b>220kWh per year</b>	<b>£53.90</b>
Steam Iron 	Power: <b>2400W</b>	1 hour a week: <b>125.14kWh per year</b>	<b>£30.66</b>
2kW Fan Heater 	Power: <b>2000W</b>	3 hours a day for 4 months of the year: <b>720kWh per year</b>	<b>£176.40</b>
7kg Tumble Dryer 	_____	Manufacturer quotes <b>520kWh per year</b>	<b>£127.40</b>
Kettle 	Power: <b>3000W</b>	10 minutes a day: <b>182.50kWh per year</b>	<b>£44.71</b>
Hair Dryer 	Power: <b>2300W</b>	15 minutes per day: <b>209.88kWh per year</b>	<b>£51.42</b>

This Energy Consumption Comparison is a guide to help understand the difference between running the Vent-Axia Revive versus other everyday electrical items. Running costs will vary depending on use. The energy price shown in this comparison sheet is based on the energy price cap of per kWh (not including standing charge). This price will vary depending on region, energy supplier and energy price changes.



## Vent-Axia®

Switchee-enabled Revive 7 fan gives you real-time data on fan use and performance

When installing Switchee-enabled devices, you must scan the QR code and follow installation instructions so that data from fan can be transmitted.



- For support with Revive 7 talk to our friendly team on 0344 856 0590 or visit [www.vent-axia.com/revive7\\_switchee\\_enabled](http://www.vent-axia.com/revive7_switchee_enabled).
- For support pairing Switchee device scan the QR code, go to [switchee.com/install-revive7](http://switchee.com/install-revive7) or call 0800 133 7957.





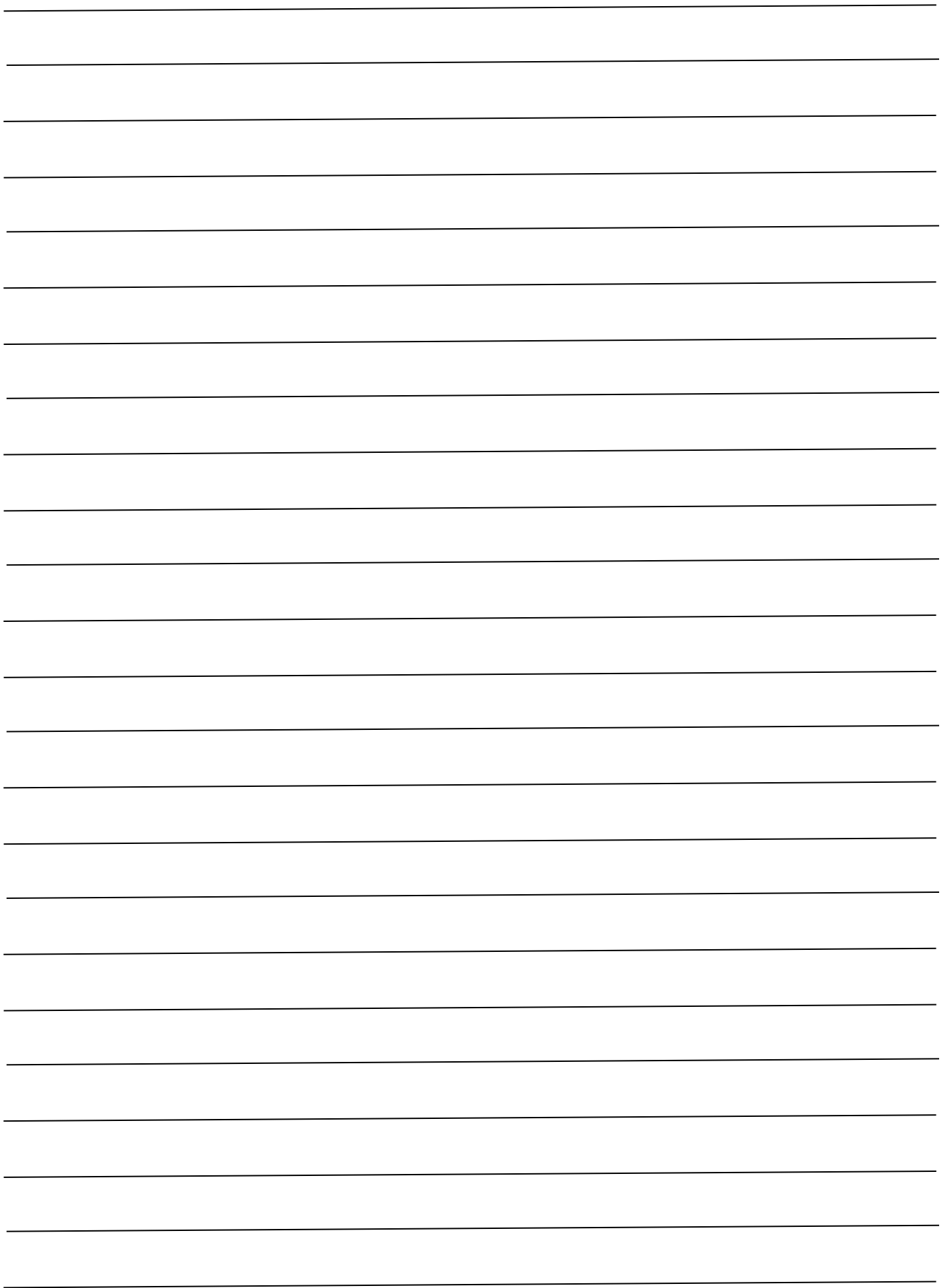

## Disposal



This product should not be disposed of with household waste. Please recycle where facilities exist. Check with your local authority for recycling advice.

## The **Vent-Axia** Guarantee

Applicable only to products installed and used in the United Kingdom. For details of guarantee outside the United Kingdom contact your local supplier.

Vent-Axia guarantees the Revive and Revive 5 for five years and the Revive 7 for seven years from date of purchase against faulty material or workmanship. In the event of any part being found to be defective, the product will be repaired, or at the Company's option replaced, without charge, provided that the product:-

- Has been installed and used in accordance with the instructions given with each unit.
- Has not been connected to an unsuitable electricity supply. (The correct electricity supply voltage is shown on the product rating label attached to the unit).
- Has not been subjected to misuse, neglect or damage.
- Has not been modified or repaired by any person not authorised by the company.

### IF CLAIMING UNDER TERMS OF GUARANTEE

Please return the complete product, carriage paid to your original supplier or nearest Vent-Axia Centre, by post or personal visit. Please ensure that it is adequately packed and accompanied by a letter clearly marked "Guarantee Claim" stating the nature of the fault and providing evidence of date and source of purchase.

The guarantee is offered to you as an extra benefit, and does not affect your legal rights

## **Vent-Axia**

Head Office: Fleming Way, Crawley, West Sussex, RH10 9YX.

EU Authorised Representative: Vent-Axia Sigarenmaker 5 - 5521DJ Eersel Nederland [authorisedrep@vent-axia.nl](mailto:authorisedrep@vent-axia.nl)

**UK NATIONAL CALL CENTRE**, Newton Road, Crawley, West Sussex, RH10 9JA

SALES ENQUIRIES: Tel: 0344 856 0590 Fax: 01293 565169

TECHNICAL SUPPORT: Tel: 0344 856 0594 Fax: 01293 532814

For details of the warranty and returns procedure please refer to [www.vent-axia.com](http://www.vent-axia.com) or write to Vent-Axia, Fleming Way, Crawley, RH10 9YX