



dMEV Round Fan Range

Installation and Wiring Instructions



Code:- MON-DMEVR100

Code:- MON-DMEVR100HT

Code:- MON-DMEVR125

Code:- MON-DMEVR125HT



**PLEASE READ INSTRUCTIONS IN CONJUNCTION WITH ILLUSTRATIONS.
PLEASE SAVE THESE INSTRUCTIONS.**

IPX5



**IMPORTANT:
READ THESE INSTRUCTIONS BEFORE COMMENCING THE
INSTALLATION**

DO NOT install this product in areas where the following may be present or occur:

- Excessive oil or a grease-laden atmosphere.
- Corrosive or flammable gases, liquids or vapours.
- Ambient temperatures higher than 40°C or less than -5°C.
- Possible obstructions that would hinder the access or removal of the Fan.

SAFETY AND GUIDANCE NOTES

- A.** All wiring to be in accordance with the current I.E.E. Regulations within the UK, or the appropriate standards of your country and **MUST** be installed by a suitably qualified person.
- B.** The Fan should be provided with a local isolator switch capable of disconnecting all poles, having a contact separation of at least 3mm.
- C.** Ensure that the mains supply (Voltage, Frequency, and Phase) complies with the rating label.
- D.** The Fan should only be used in conjunction with the appropriate Monsoon products.
- E.** The fan should only be used in conjunction with fixed wiring.
- F.** When the Fan is used to remove air from a room containing a fuel-burning appliance, ensure that the air replacement is adequate for both the fan and the fuel-burning appliance. Precautions must be taken to avoid the back-flow of gases into the room from any open flue of gas or other fuel burning appliances.
- G.** The Fan should not be used where it is liable to be subject to direct water spray for prolonged periods of time.
- H.** Where ducted Fans are used to handle moisture-laden air, insulated ducting or a condensation trap should be fitted. Horizontal ducts should be arranged to slope slightly downwards away from the Fan.

- I. This appliance is not intended for use by persons (including children) with reduced physical, sensory or mental capabilities, or lack of experience and knowledge, unless they have been given supervision or instruction concerning use of the appliance by a person responsible for their safety.
- J. Young children should be supervised to ensure that they do not play with the appliance.

DESCRIPTION

The Monsoon dMEV round fan is a continuously running extract fan for kitchens, utility rooms, bathrooms and toilets. The incorporated speed control dial allows the fan to be configured to suit the installation airflow requirements. All models include a fixed Overrun Timer with Comfort Mode and external wind pressure detection as standard. The HT models include a digital humidity sensor with pre-set Threshold and Rapid Rise sensing.

- **MON-DMEVR100** - 100mm continuously running dMEV fan with fixed Timer
- **MON-DMEVR100HT** - 100mm continuously running dMEV fan with Humidity sensor and fixed Timer
- **MON-DMEVR125** - 125mm continuously running dMEV fan with fixed Timer
- **MON-DMEVR125HT** - 125mm continuously running dMEV fan with Humidity sensor and fixed Timer

A. INSTALLATION

PANEL/CEILING/ INTERIOR WALL MOUNTING

1. Cut a 107mm diameter hole for 100mm fans or a 130mm hole for 125mm fans. Note: The 100mm and 125mm fans have outer product diameters of 190mm and 220mm respectively, when positioning the fan, please provide at least 10cm between any adjacent walls or ceilings and the fan.
2. Remove the front tile carefully pulling away from the fan.
3. Loosen the 3 grille screws to remove inner grille.
4. Mark the screw centres through the holes in the fan back plate. Drill, plug and screw into position. Attach ducting as required for the installation – (Please see **Condensation** section below).
5. Wire the fan as described in Section B-Wiring. Adjust any settings as required (see Section C-Setup).
6. After installation, ensure impeller rotates freely.
7. Replace the inner grille and tighten the retaining screws. Place tile front onto the inner grille by aligning the fixings and pushing the tile front on.

CONDENSATION BUILD UP

Where ducted Fans are used to handle moisture-laden air, insulated ducting or a condensation trap should be fitted to prevent water regularly draining onto the building structure/plasterboard and/or the fan. Horizontal ducts should be arranged to slope slightly downwards away from the Fan.

EXTERIOR WALL MOUNTING

1. For wall mounting cut a 117mm diameter hole (100mm fans) or a 140mm hole (125mm fans) through the wall and insert the wall sleeve. Slope the sleeve slightly downwards away from the fan. Where necessary cut to length and cement both ends into position flush with the wall faces. The 100mm and 125mm fans have outer product diameters of 190mm and 220mm respectively, when positioning the fan, please provide at least 10cm between any adjacent walls or ceilings and the fan.
2. Fix exterior grille into position with the louvres positioned downwards.
3. Remove the front tile carefully pulling away from the fan.
4. Loosen the 3 grille screws to remove inner grille.
5. Mark the screw centres through the holes in the fan back plate. Drill, plug and screw into position. Attach ducting as required for the installation.
6. Wire the fan as described in Section B-Wiring. Adjust any settings as required (see Section C-Setup).
7. After installation, ensure impeller rotates freely.
8. Replace the inner grille and tighten the retaining screws. Place tile front onto the inner grille by aligning the fixings and pushing the tile front on.

B. WIRING.



WARNING: THE FAN AND ANCILLARY CONTROL EQUIPMENT MUST BE ISOLATED FROM THE POWER SUPPLY DURING INSTALLATION OR MAINTENANCE.

IMPORTANT

- The cross - sectional area of supply cord used should be ranged from 0.75 -1.5mm².
- This is a fixed wired product; flexible cord must not be used.
- The fan is a class II double insulated product and does not need to be earthed.

1. Wiring can be made from either the side or rear of the fan. Ensure the rubber seal integrity is maintained when piercing a hole for the cable.
2. If using side entry, wiring must be retained in suitable conduit.
3. Select and follow the appropriate wiring diagram. (**Fig. 1, 2 or 3**)
4. Check all connections have been made correctly.
5. Ensure the impeller rotates and is free from obstructions.

C. SETUP

Installation Settings:

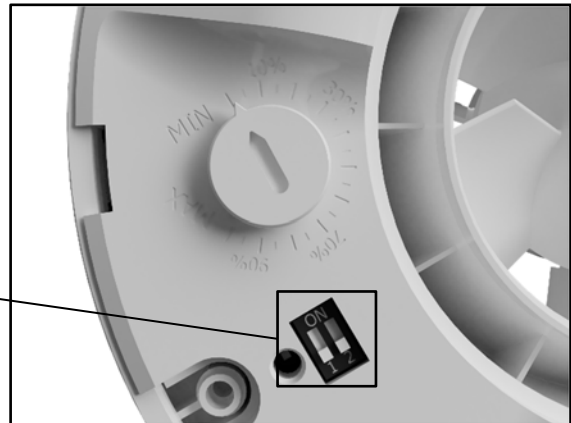
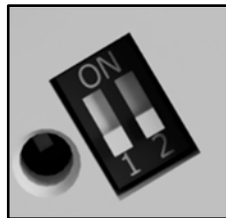

Dip Switch 1 (SW1) (default OFF): This determines the installation type, wall or ducted.

- OFF = Wall Installation (default)
- ON = Ducted installation

Dip Switch 2 (SW2) (default OFF): This enables (ON) or disables (OFF) the wind pressure detection system. During windy conditions, it is possible for the extract flow rates to be reduced momentarily. The automatic wind pressure system detects the reduced flow rates and increases the fan speed to compensate. The system only reacts if there is a sustained and excessive wind present to reduce nuisance noise/activation.

Speed Selection

The fan speed is only adjustable within the first 5 minutes of mains power. The trickle flow rate can be quickly adjusted via the dial as shown – either with the inner grille on or off (see below images). The 10-100% scale relates to a flow rate of between 5-24l/s and 5-26l/s for the 100mm and 125mm models respectively. The scale is adjusted based on the installation type (**SW1**). The boost speed is proportionally higher than the trickle flow rate.

Inner grille on:

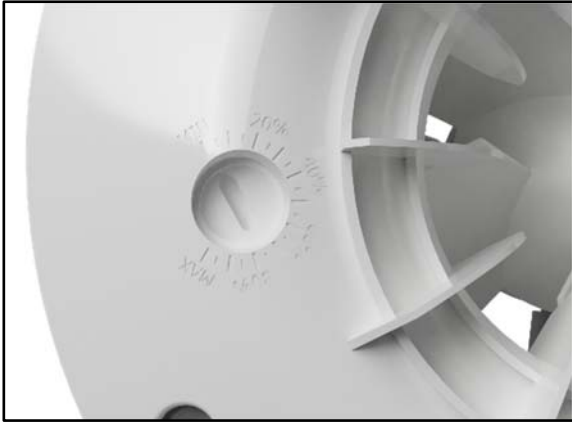

Inner grille removed:



Speed can be adjusted while the fan is isolated from the mains with the inner grille removed or with the inner grille screwed on and the fan powered up. Note the fan speed is only adjustable within the first 5 minutes of mains power.

Overrun Timer with Integrated Comfort mode (Overrun Timer by default is disabled)*

The comfort mode feature offsets/delays the boost when the LS has been activated (e.g. from switching the light on) until after the LS has been deactivated (up to a maximum of 20 minutes). Therefore reducing any nuisance noise until after the user has left the room.

When the LS is deactivated, fan will run at boost mode for the length of time the LS was present (up to a maximum of 20 minutes) plus the standard 15 minute overrun time.

If the LS was activated for less than 3 minutes, no boost will occur to prevent nuisance activations.

If the LS is still connected after 20 minutes, the fan will boost anyway. Once the LS is disconnected, the fan will run for only 20 minutes plus the 15min overrun timeout.

The humidity sensor overrides this if humidity is detected. The fan will run as described for the Humidity function.

*To enable comfort mode:

1. Power cycle the fan. Wait 30 seconds.
2. Switch LS on and off 5 times within 20 seconds (leaving a minimum of 1 second between each consecutive toggle).
3. Comfort mode is now enabled.
4. The Comfort mode setting persists between power cycles. To disable, repeat instructions 1 and 2.

Inbuilt Threshold Humidistat with Rapid Rise Detection (HT models only)

The HT models include a digital humidity sensor with pre-set Threshold and Rapid Rise sensing. The settings are fixed and cannot be adjusted.

Threshold:

The fan will increase in speed proportionally between trickle and boost flow rates at 75%RH and 85%RH.

- 0-75%RH = Trickle speed flow rate
- 76-85%RH = Proportional between trickle and boost
- 86-100%RH = Boost speed flow rate

Rapid Rise Detection:

If the humidity increases by more than 5%RH (RH2) compared to the humidity 5 minutes ago (RH1), the fan enters boost mode. Once the humidity starts to fall, the fan will remain in boost for a further 30 minutes or until the humidity reaches the original (RH1) humidity level, whichever is sooner.

D. SERVICING AND MAINTENANCE.



WARNING: THE FAN AND ANCILLARY CONTROL EQUIPMENT MUST BE ISOLATED FROM THE POWER SUPPLY DURING MAINTENANCE.

1. At intervals appropriate to the installation, the fan should be inspected and cleaned to ensure there is no build-up of dirt or other deposits.
2. Wipe the inlets and front face with a damp cloth until clean.

The fan has sealed for life bearings, which do not require lubrication.

Fig.1 Continuous trickle (no manual boost). (The fan is internally fused)

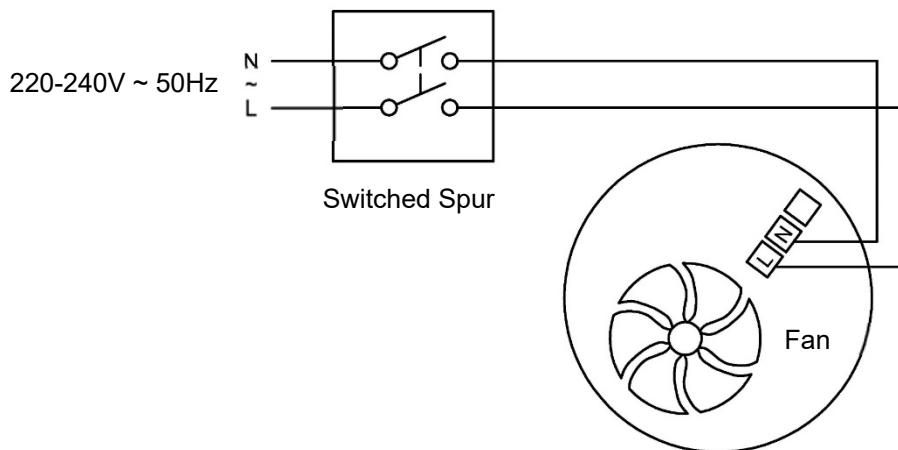

Fig.2 Continuous boost with no trickle facility. (The fan is internally fused)

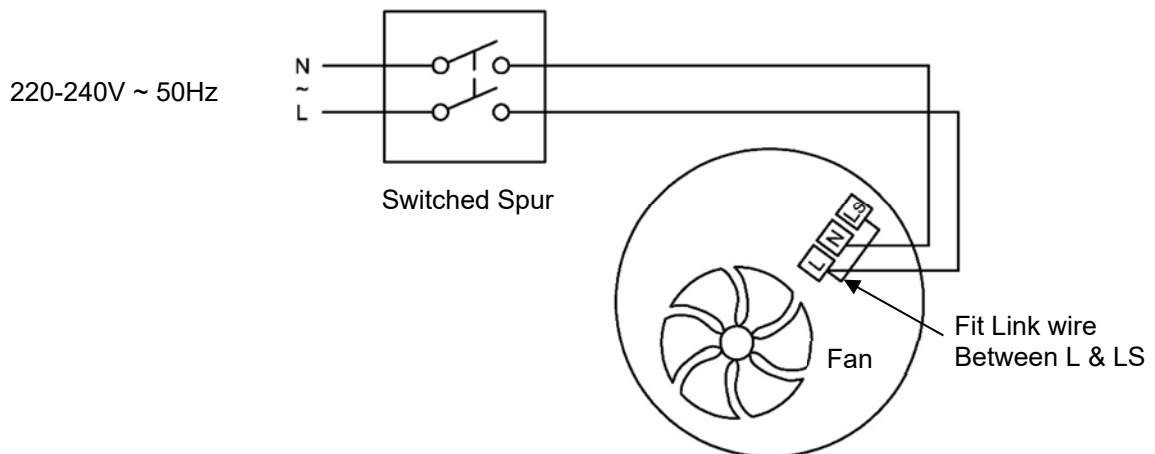
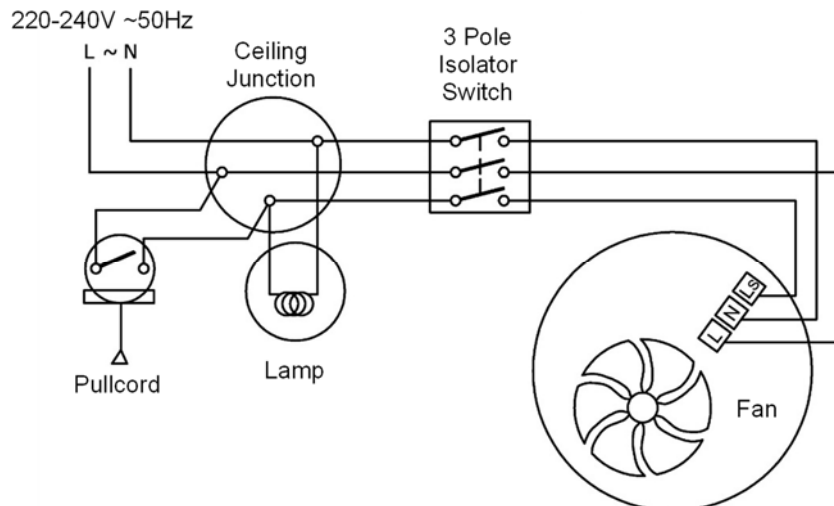
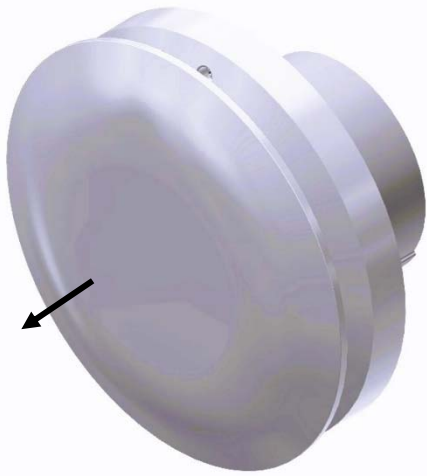

Fig.3 Continuous trickle with boost facility. (The fan is internally fused)



1. Remove tile cover



2. Loosen 3 grille screws (do not fully remove) and pull the inner grille forward off the fan

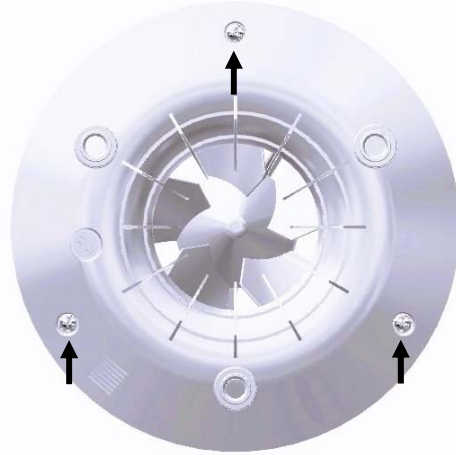

Mounting fixing

Speed
Adjustment
Dial

Installation mode (SW1)
Wind Pressure Detection (SW2)

Wiring terminals (220-240VAC ~ 50Hz)

Mounting fixing

Rear cable entry

Side cable entry
(cut plastic side
wall to access)

Mounting fixing

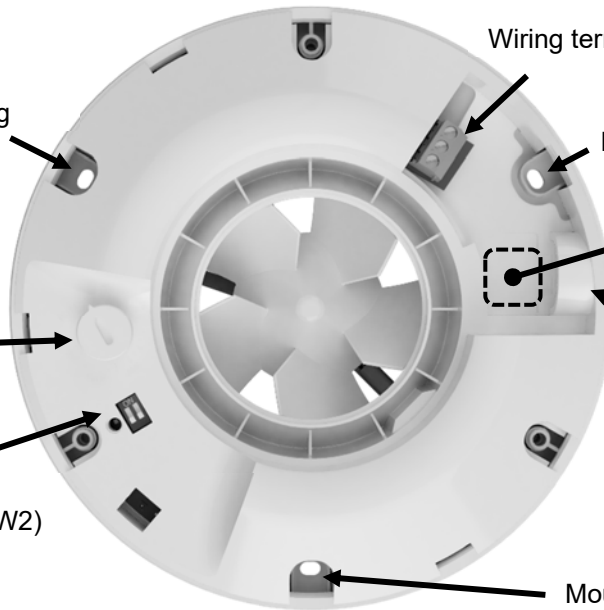

Quick Setup

- 1) Ensure fan is isolated from mains.
- 2) Set the installation type – wall or ducted (SW1)
- 3) Set trickle flow rate – Dial as shown in the table below.

Humidity models: The humidity sensor is fully automatic and does not require setting.
Boost speed is fixed at 50% higher than the set trickle rate.

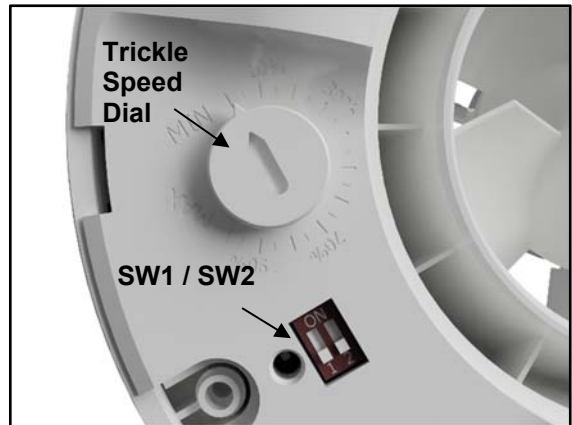

Speed Setting:

Dial Position %	Installation Type (Typical examples)			
	Wall (l/s) (SW1 Off)		Ducted 5.5m (l/s) (SW1 ON)	
	100mm	125mm	100mm	125mm
20	5	5	5	5
25	6	6	6	6
30	7	7	8	8
35	8	8	11	11
40	10	13	12	14
45	12	16	15	15
50	14	17	16	17
55	14	19	17	18
60	15	21	18	20
65	16	22	19	21
70	17	24	21	22
75	18	25	21	23
80	18	26	22	24
85	19	26	22	24
90	20	26	23	26
95	Speed Limited in Wall Mode		24	26
100	Setting (SW1)		24	26

Note the fan speed is only adjustable within the first 5 minutes of mains power.

Using Vane Anemometers: Please refer to the operating manual for your Vane Anemometer/other types of airflow meters that use hoods. The airflow typically reduces by 20% due to the additional resistance from the hood and vane anemometer. Care should be taken to ensure the correct hood is used to prevent excessive resistance due to the tile cover.

For more details please refer to Setup section

PRODUCT FICHE

For Residential Ventilation Units (Complying Commission Delegated Regulation (EU) No 1254/2014)

Name:	National Ventilation	National Ventilation	National Ventilation	National Ventilation
Model ID (Stock Ref.) :	MON-DMEVR100	MON-DMEVR100HT	MON-DMEVR125	MON-DMEVR125HT
SEC Class	E	C	E	C
SEC Value ('Average')	-14.90	-25.85	-14.31	-25.57
SEC Value ('Warm')	-6.29	-11.48	-5.70	-11.20
SEC Value ('Cold')	-29.93	-50.93	-29.35	-50.65
Label Required? (Yes/No=Out of scope)	No	No	No	No
Declared as: RVU or NRVU/UVU or BVU	RVU-UVU	RVU-UVU	RVU-UVU	RVU-UVU
Speed Drive	Variable Speed	Variable Speed	Variable Speed	Variable Speed
Type HRS (Recuperative, Regenerative, None)	None	None	None	None
Thermal Eff: [(%), NA(if none)]	N/A	N/A	N/A	N/A
Max. Flow Rate (m3/h)	57.60	57.60	57.60	57.60
Max. Power Input (W): (@Max.Flow Rate)	1.51	1.51	2.61	2.61
LWA: Sound Power Level (dB)	33.22	33.22	40.32	40.32
Ref. Flow Rate (m3/s)	0.01	0.01	0.01	0.01
Ref. Pressure Diff. (Pa)	N/A	N/A	N/A	N/A
SPI [W/(m3/h)]	0.03	0.03	0.05	0.05
Control Factor & Control Typology: (CTRL/ Typology)				
Control Factor; CTRL	0.95	0.65	0.95	0.65
Control Typology	Clock Control	Local Demand Control	Clock Control	Local Demand Control
Declared: -Max Internal & External Leakage Rates(%) for BVUs or carry over (for regenerative heat exchangers only), -&Ext. Leakage Rates (%) for Ducted UVUs;	N/A	N/A	N/A	N/A
Mixing Rate of Non-Ducted BVUs not intended to be equipped with one duct connection on either supply or extract air side;	N/A	N/A	N/A	N/A
Position and description of visual filter warning for RVUs intended for use with filters, including text pointing out the importance of regular filter changes for performance and energy efficiency of the unit	N/A	N/A	N/A	N/A
For UVUs (Instructions Install Regulated Supply/Extract Grilles Façade)	In F&W	In F&W	In F&W	In F&W
Internet Address (for Disassembly Instructions)	www.nationalventilation.co.uk	www.nationalventilation.co.uk	www.nationalventilation.co.uk	www.nationalventilation.co.uk
Sensitivity p. Variation@+20/-20 Pa: (for Non-Ducted Vus)	N/A	N/A	N/A	N/A
Air Tightness-ID/OD-(m3/h) (for Non-Ducted Vus)	N/A	N/A	N/A	N/A
Annual Electricity Consumption: AEC (kWh/a)	0.33	0.15	0.56	0.26
Annual Heating Saved: AHS (kWh/a)				
AHS: Average	15.72	26.23	15.72	26.23
AHS: Warm	7.11	11.86	7.11	11.86
AHS: Cold	30.75	51.31	30.75	51.31

**Disposal**

This product should not be disposed of with household waste. Please recycle where facilities exist. Check with your local authority for recycling advice.

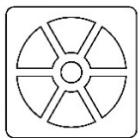

**NATIONAL
VENTILATION**



National Ventilation, Stathe Road, Burrowbridge, Somerset, TA7 0RY

EU Authorised Representative: National Ventilation Sigarenmaker 5 - 5521DJ Eersel Nederland authorisedrep@nationalventilation.nl

Website: www.nationalventilation.co.uk email: info@nvagroup.co.uk

Sales and technical hotline: 01823 690290