

Lo-Carbon PoziDry Pro

Positive Input Ventilation Unit

Installation and Wiring Instructions



Stock Ref. N°

- 476310 – PoziDry Pro
- 476311 – PoziDry Pro with Heater
- 476312 – PoziDry Pro FD

220-240V~50Hz

Vent-Axia®

PLEASE READ INSTRUCTIONS IN CONJUNCTION WITH THE ILLUSTRATIONS.
PLEASE SAVE THESE INSTRUCTIONS

UK
CA
CE

SAFETY AND GUIDANCE NOTES**IMPORTANT:
READ THESE INSTRUCTIONS BEFORE COMMENCING THE
INSTALLATION**

1. DO NOT install this product in areas where the following may be present or occur:
 - 1.1. Excessive oil or a grease laden atmosphere.
 - 1.2. Corrosive or flammable gases, liquids or vapours.
 - 1.3. Ambient temperatures higher than 40°C or less than -5°C.
 - 1.4. Possible obstructions which would hinder access or removal of the Fan.
 - 1.5. Relative humidity above 90%
 - 1.6. Sudden ductwork bends or transformations close to the Unit.
2. All wiring to be in accordance with the current I.E.T. Regulations, or the appropriate standards of your country and MUST be installed by a suitably qualified person.
3. The fan must be provided with an isolator switch capable of disconnecting all poles, having a contact separation of at least 3mm.
4. Ensure that the mains supply (voltage, frequency, and phase) complies with the fan's rating label.
5. The fan should not be used where it is liable to be subjected to direct water spray.
6. This appliance can be used by children aged from 8 years and above and persons with reduced physical, sensory or mental capabilities or lack of experience and knowledge if they have been given supervision or instruction concerning use of the appliance in a safe way and understand the hazards involved. Children shall not play with the appliance. Cleaning and user maintenance shall not be made by children without supervision.
7. Precautions must be taken to avoid the back-flow of gases into the room from the open flue of gas or other fuel-burning appliances.
8. Children of less than 3 years should be kept away unless continuously supervised.
9. Children aged from 3 to 8 years shall only switch on/off the appliance provided the unit is installed as intended for normal operation and they have been given supervision or instruction concerning safe use of the appliance and understand the hazards involved.
10. Children aged 3 to 8 shall not plug in, regulate and clean the appliance or perform user maintenance.

Caution - some parts of this product can become very hot and cause burns. Particular attention has to be given where children and vulnerable people are present.

A. INTRODUCTORY NOTES

The Vent Axia Lo-Carbon PoziDry Pro is a positive input ventilation unit, designed to be installed in the loft of a dwelling to continually supply filtered fresh air into the building. The system consists of a fan unit, a heater unit (for heater models) and a diffuser (for diffuser models) with a short length of flexible ducting.

The Lo-Carbon PoziDry Pro has two fully adjustable speed settings; 'Trickle' and Energy recovery'. These speeds are set during installation; there are four pre-set speeds or an option allowing the speeds to be chosen manually from 19L/s to 49L/s. The Lo-Carbon PoziDry Pro uses a sensor to monitor the temperature in the loft, automatically adjusting the air volume when necessary.

- The fan will run in 'Trickle' speed when the ambient loft temperature is less than 18°C (adjustable via the Trickle Speed Temperature Threshold setting).
- The fan will run in 'Energy recovery' speed when the ambient loft temperature is between the Trickle Speed Temperature setting (default 18°C) and Temperature Limit setting (default 27°C).
- If the ambient loft temperature exceeds the Temperature Limit setting (default 27°C), the fan will automatically switch to standby (no airflow).
- If the ambient loft temperature is below -5°C, the fan will automatically switch to standby (no airflow).
- Remote Purge/Boost is achievable by using the Boost Switch Link Connector (sold separately –411150).

The heater (if applicable) will activate when the ambient loft temperature is below the Heater Threshold Temperature set point (default is 5°C). The set point can be adjusted between 5°C and 20°C. The heater is designed to try and maintain the heater set point temperature, however will depend on the chosen flow rates and temperature of the incoming air.

The unit also incorporates a data logging function. This function will display total runtime of system, time spent in trickle speed, time spent in energy recovery speed, approximate energy consumption of the fan and approximate energy consumption of the heater unit. This data is non-resettable.

B. INSTALLATION

TYPICAL INSTALLATION

Fig. 1.

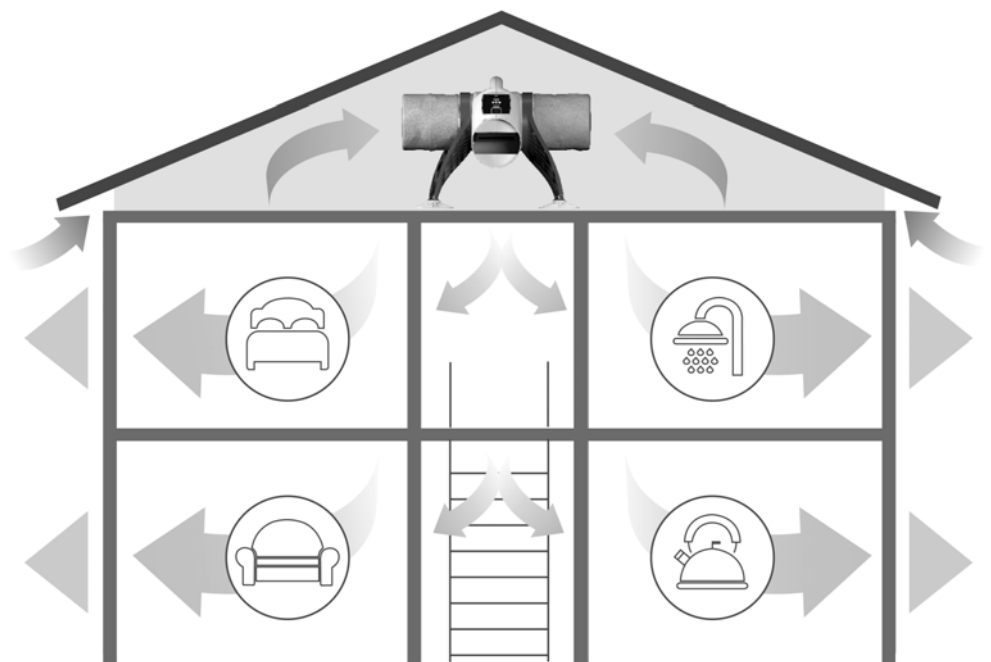

Lo-Carbon PoziDry Pro UNIT:

Prior to installation, ensure that the loft is adequately ventilated to the outside and any ceiling penetrations (for example, pipes and loft hatches) are well sealed as described in approved Document C of the UK Building Regulations or BS 5250:2021.

Ensure that the ceiling void is free from mould or other potential contaminants.

Ensure that all water tanks are covered and sealed.

Check that all water pipes are lagged.

Ensure that any extract fans are discharging to the outside and not into the loft.

Check that the loft hatch is tightly sealed.

Ensure that all holes in the ceilings are sealed, i.e. ceiling light fittings etc.

A visual inspection of any flues or chimneys for leakage in the loft should be carried out by the installer.

Flexible ducting is supplied as standard. Ensure that this is pulled out into a smooth single curve to the grille – with no additional bends or excess ducting. If the application requires a fixed 90 degree bend, straight ducting may be used. See Spares and Accessories section.

The fan unit can be floor mounted or hung from a roof beam.

Hanging method:

The Lo-Carbon PoziDry Pro can be hung from a roof beam (Fig. 2). Fix the screw eye to a convenient roof beam. Use the cord provided to loop through the eye and around the handle on the unit, there are various notches for the cord to run through, tie the two ends together using a suitable knot such as an over hand or fisherman's knot.

Ensure that the route for the flexible ducting has gentle bends and that the duct cannot be crushed. See **Diffuser Grille Fitment** section below for more information.

Fit the filters to the unit. **Please make sure that the filters are fitted correctly. This will ensure that all the fresh air entering the dwelling has passed through the filter first.**

Ensure that the screw eye is attached to the beam strongly enough and that the beam is in sufficient condition to withstand the load. The unit weight is approximately 4 kg.

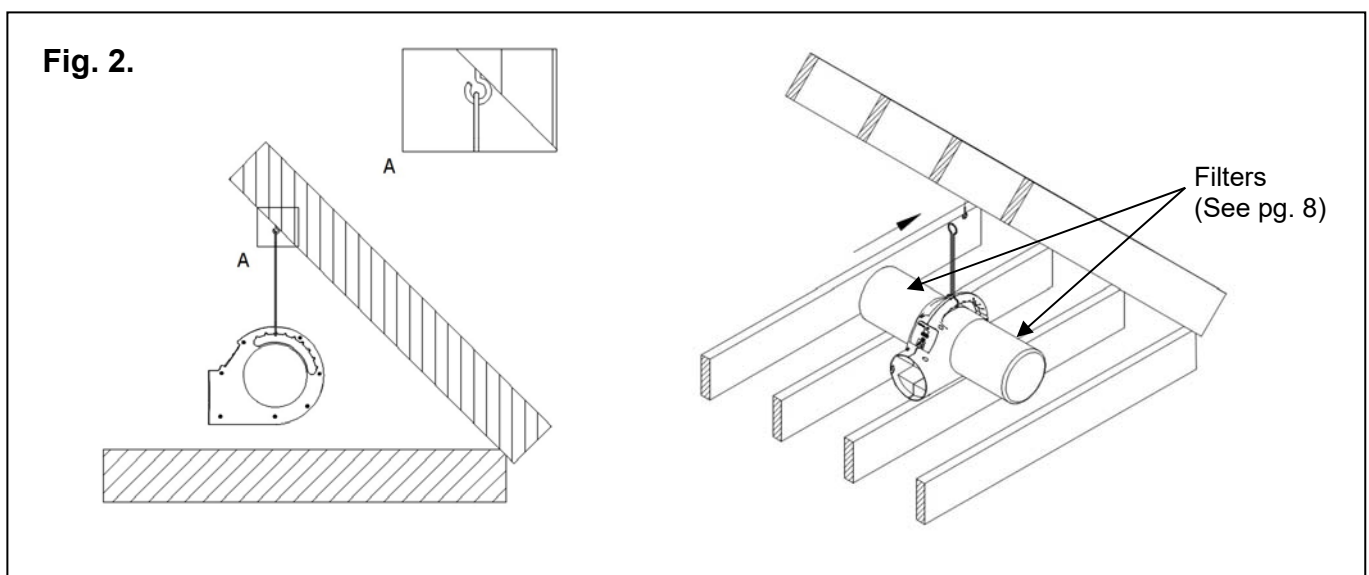

Floor mounting:

Attach the mounting legs to the unit, two per side.

Find a suitable location to fix the unit near to where the diffuser is to be located. Ensure that the route for the flexible ducting has gentle bends and that the duct cannot be crushed Fig.3. See **Diffuser Grille Fitment** section below for more information.

The legs and feet can be adjusted to suit ceiling joists of varying spans. Adjust the legs and feet so that the unit spans over two joists. Secure the feet to the joists with screws, Fig.4. In the unlikely event that the legs cannot span the ceiling joists affix the unit to a wooden board or two lengths of timber which can then be screwed to the joists.

Fit the filters to the unit. **Please make sure that the filters are fitted correctly. This will ensure that all the fresh air entering the dwelling has passed through the filter first.**

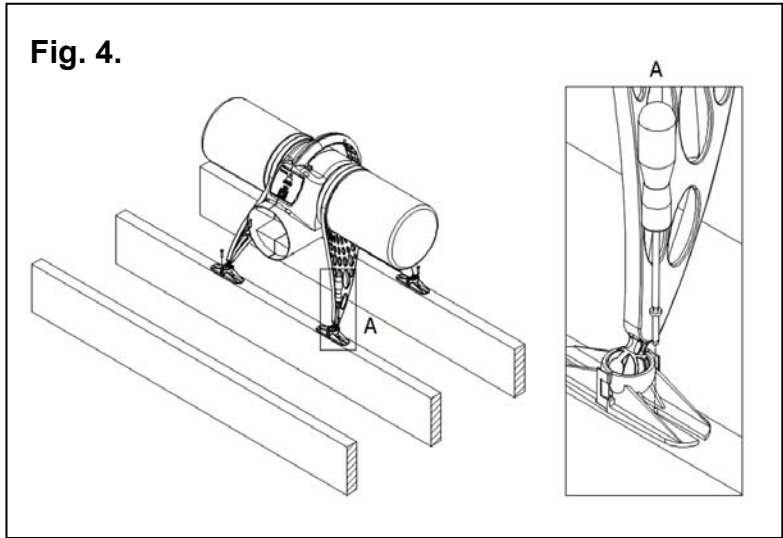
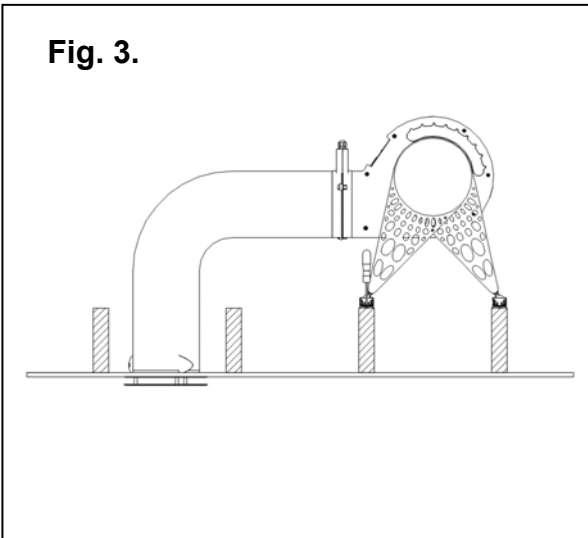

400-600mm Joist Dimensions with Unit Clearance Heights

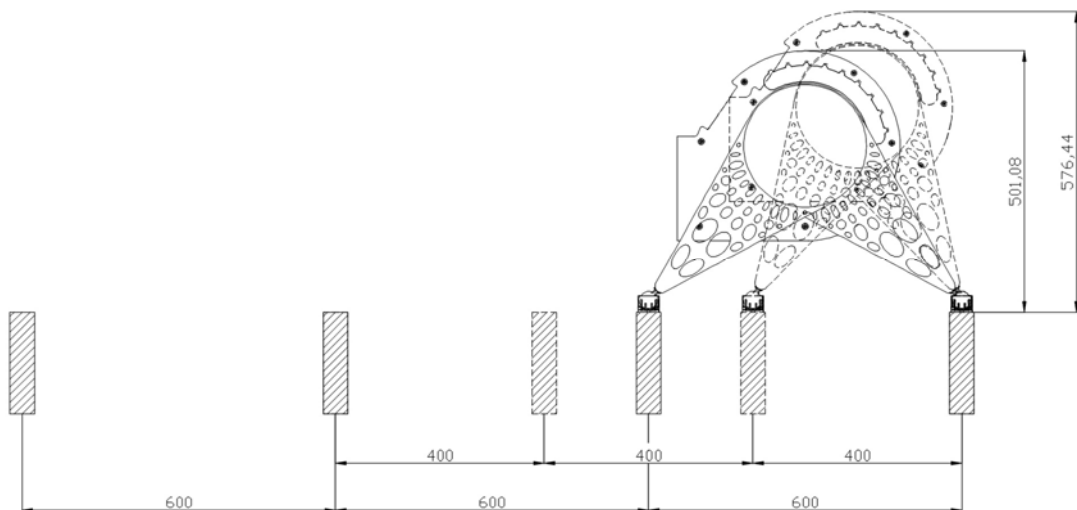

Diffuser Grille Fitment:

The diffuser must be carefully sited to ensure the maximum effectiveness of the system. It should be fitted in the ceiling of a common area, ideally above the landing so that the incoming air can reach all the rooms.

Cut the flexible ducting to a suitable length, where possible stretch the ducting to its maximum extent and ensure that there is one continuous smooth bend to the diffuser. The ducting **must** remain a minimum of 1m in length.

Remove the loft insulation from the location of the diffuser and cut a 240-260mm diameter hole in the ceiling (only for PoziDry Pro & PoziDry Pro with Heater).

For PoziDry Pro FD (476312) model, cut hole in ceiling to suit the outside diameter of the air valve mounting ring.

Remove the domed cover panel using a small flat blade screw driver to prise it from the assembly.

Ensure the four locking tabs are folded in and then push the spigot in to the hole. Holding the diffuser in place; screw the four screws until the locking tabs are holding the diffuser tight against the ceiling (Fig.5). **It is important not to over tighten these screws as this may warp the diffuser.** Refit the domed cover panel.

Fit the free end of the flexible ducting to the diffuser spigot using the worm drive clip supplied.

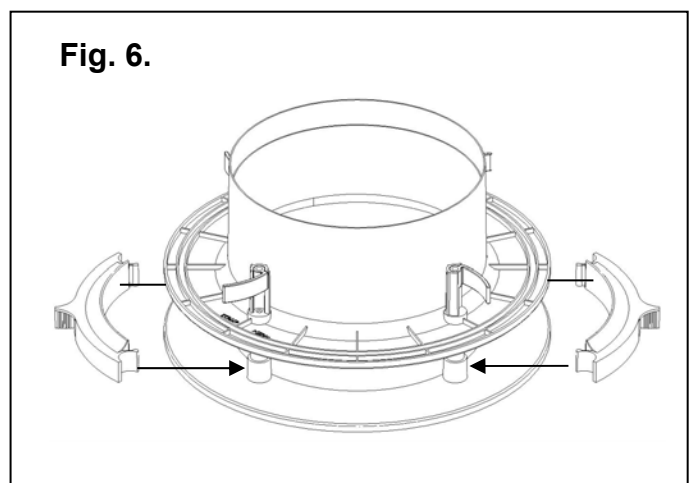
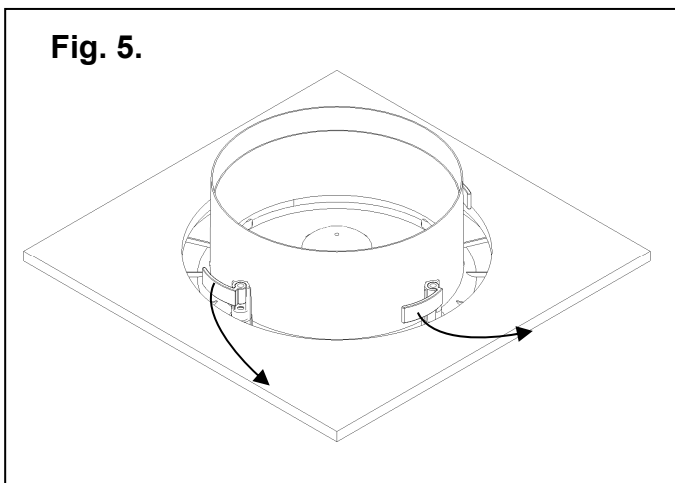

IMPORTANT – SMOKE DETECTORS: The diffuser should have at least 1.5m of unobstructed area from the smoke sensor to allow the air to flow efficiently round the property, however if this is not possible the Lo-Carbon PoziDry Pro has provisions to blank off the airflow for up to two quadrants of the diffuser. Two blanking plates are provided; these should be pushed on to the support struts inside the diffuser as required. This should be done before the diffuser is installed in the ceiling as when the screws are tightened down the plates can no longer be removed. See Fig.6, showing blocking off opposing quadrants, note any 1 or pair of quadrants can be blocked off as necessary for the install. These block off plates can also be used to ensure the supply air is spread across a room rather than directed at close by walls.

Blanking off one side reduces the flow by about 6%, but blanking off two sides reduces the flow by about 20% and so if two sides are blanked off then you should consider increasing the fan speed to maintain the appropriate airflow.

TWIN SPIGOT OPTION

(PIV twin spigot kit Ref:- 449071)

Ensure that the adjustable diffuser supplied with the kit is installed nearer to the PoziDry Pro unit than the diffuser supplied with the unit (Fig.7). This allows both flows to be balanced.

Not to be used with FD models unless the diffuser supplied with the kit is replaced with diffuser part 475664.

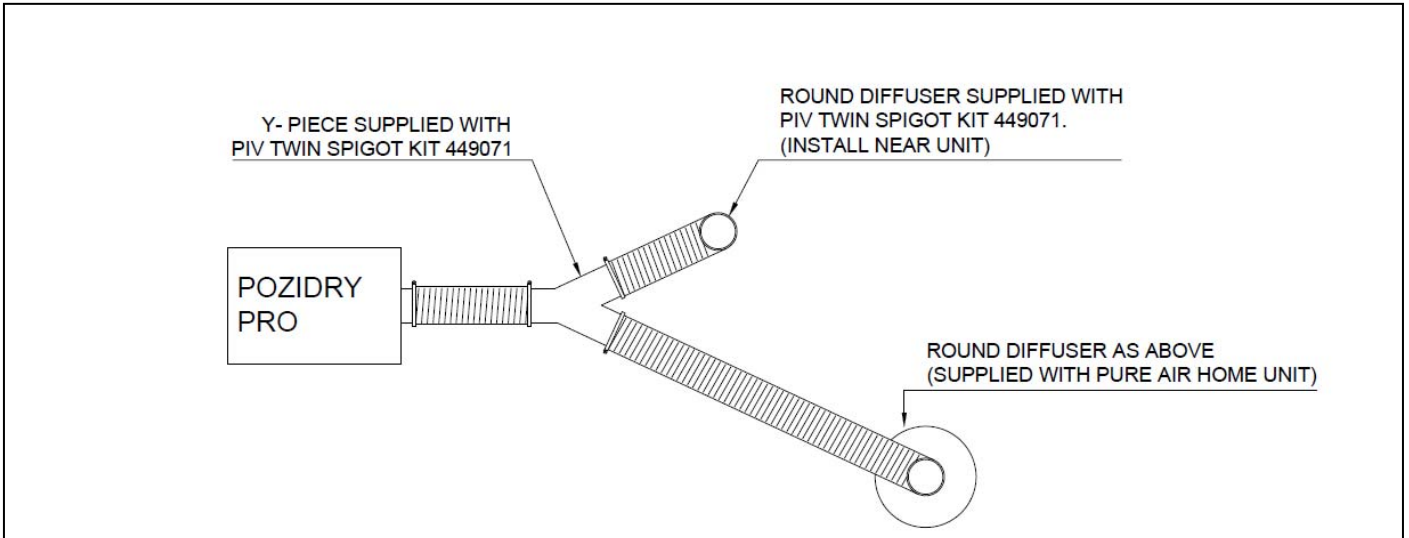

Ducting fitment

Ensure the ducting is securely fixed to the diffuser and fan (or heater if applicable) via the provided worm drive clips. (Fig 8)

Heater Unit:

The fan/heater unit must not be located directly below a socket.

Fig. 8: Apply worm drive clips provided in positions shown

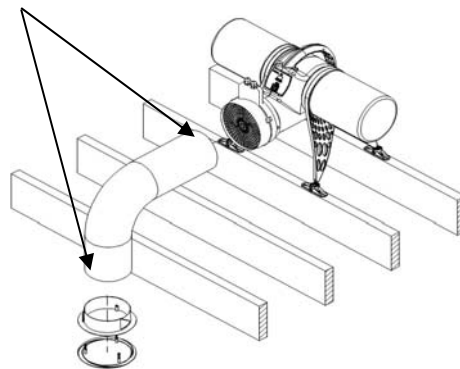
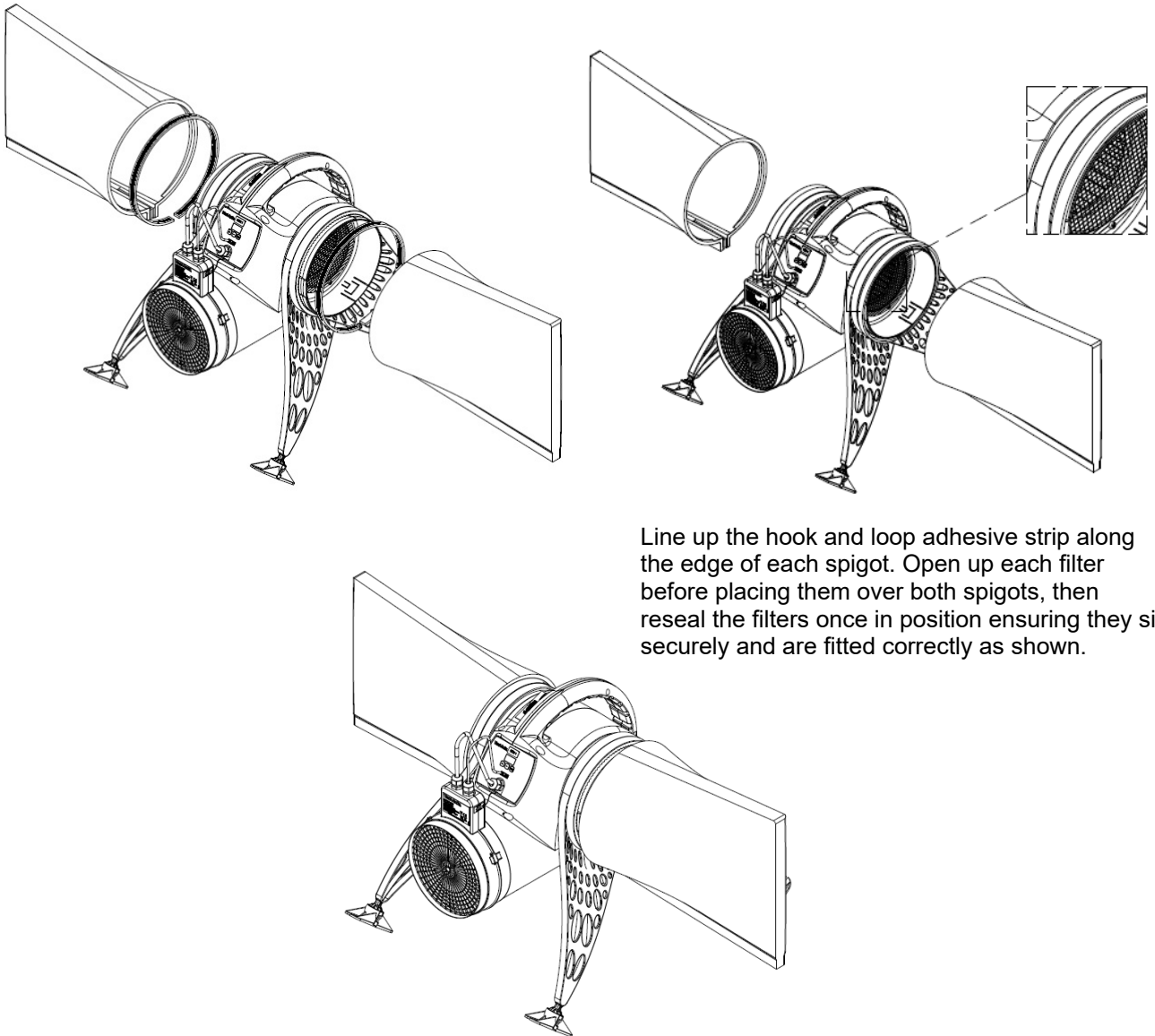

Fig. 9.



Line up the hook and loop adhesive strip along the edge of each spigot. Open up each filter before placing them over both spigots, then reseal the filters once in position ensuring they sit securely and are fitted correctly as shown.

The Lo-Carbon PoziDry Pro is provided with G4 filters which are suitable for removing airborne contaminants such as pollen and dust.

Where higher grade filtration is required, optional F7 filters can be used. These filters are effective at removing finer particles such as particulate emissions from diesel engines. In urban areas close to main roads F7 filters are advisable in order to ensure the supply air is clear of these particles which are potentially harmful to health.

Where F7 filters are fitted, please ensure the flow rate of the fan is as expected. F7 filters cause extra system resistance so it may be necessary to increase the fan speed to compensate.

C. WIRING

A means for disconnection must be incorporated into the fixed wiring in accordance with the wiring regulations.



WARNING: THE POSITIVE VENTILATION UNIT AND ANCILLARY CONTROL EQUIPMENT MUST BE ISOLATED FROM THE POWER SUPPLY DURING THE INSTALLATION / OR MAINTENANCE.

The Lo-Carbon PoziDry Pro is designed for operation from a single-phase alternating current source (220-240V AC).

A 2m integral mains flying lead is connected to the unit for connection to a spur. It should be capable of disconnecting all poles, having a contact separation of at least 3mm.

WARNING: If the supply cord is damaged, it must be replaced by the manufacturer, its service agent or a similarly qualified person in order to avoid a hazard.

PoziDry Pro & PoziDry Pro with Heater unit:

- Ensure the local AC power supply is isolated.
- The product has a pre-wired flying lead. Connect the brown core to Live and the blue core to Neutral.
- Use cable clamps and clips to secure the cable, as appropriate.

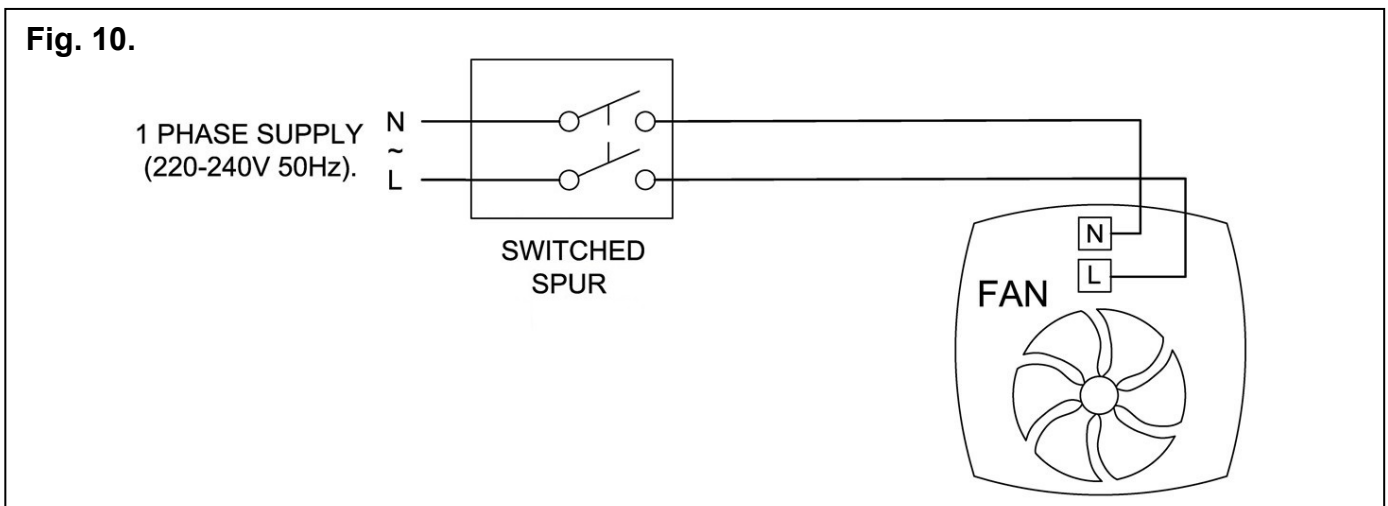

IMPORTANT:
PoziDry Pro Fire Damper (FD) models (e.g. 476312) must be fitted with a smoke alarm with a relay to ensure compliance with building regulations.

In order to have the product switch off in the event of a fire it must be wired using a smoke alarm with a relay system.

Use Fig.11 as a reference and refer to the instructions provided by the manufacturer of the smoke alarm and relay in order to wire the unit correctly. Ensure the relay works correctly by testing the fire alarm; the unit should switch off when the alarm is sounding.

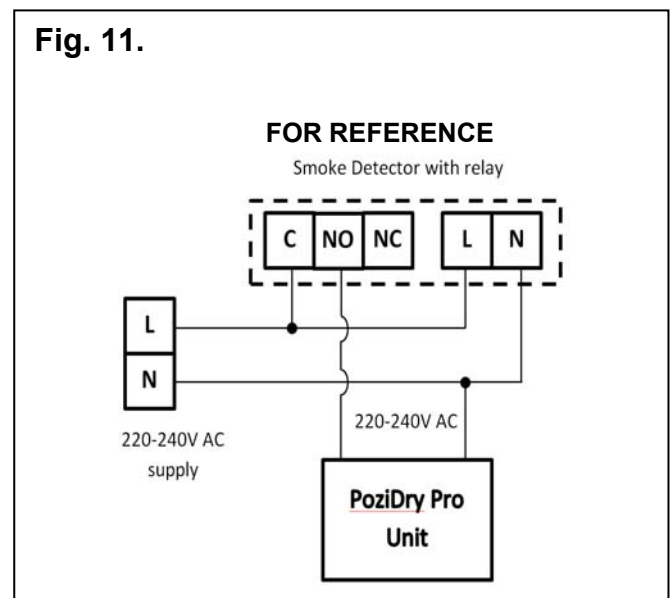

Boost Switch Link Connector option (Ref:- 411150)

IMPORTANT:

Do not connect mains or any other device to the remote boost cable. It is only intended to be linked via a remote volt free switch to activate the boost function.

- 1) Connect the boost cable (supplied with 411150) to the connector under the display (on the fan).
- 2) Wire the boost switch to the two terminals within the junction box. Ensure the cable is secured properly. The switch links the two wires together to activated boost remotely. Once deactivated the fan overruns for the set timeout period (*see bst timer within the fan menu).
 - a. Normally open – normal mode/trickle
 - b. Closed link – boost is activated.

*Within the fan menu “bst” can be set to have an overrun timer of either 0, 1hr, 2hr, 4hr, 8hr.

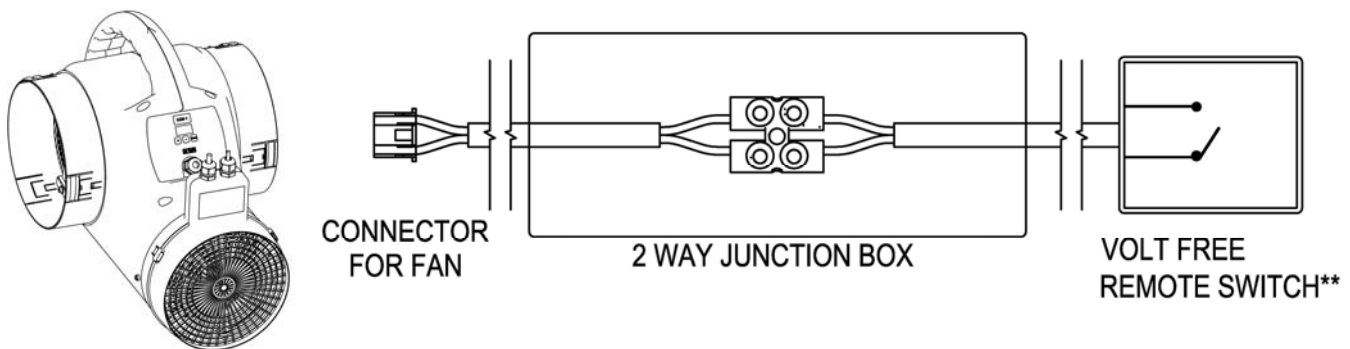

D. SETUP

START UP SEQUENCE

When the unit is switched on it will first run through a period of system checks. During this time the display will show various system parameters before the fan motor starts. After 10 seconds the product will be ready for commissioning.

COMMISSIONING

Accessing the Commissioning Menu

If the fan is powered and the display is not lit then press any button to access the menu. After 30 seconds without menu activity the display will switch off, any changes to the settings will then be applied.

There are three buttons on the front of the unit:

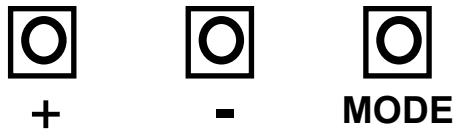

The + button is used to increase the value of a setting, the – button is used to reduce the value of a setting and the Mode button moves to the next menu item

Menu Structure

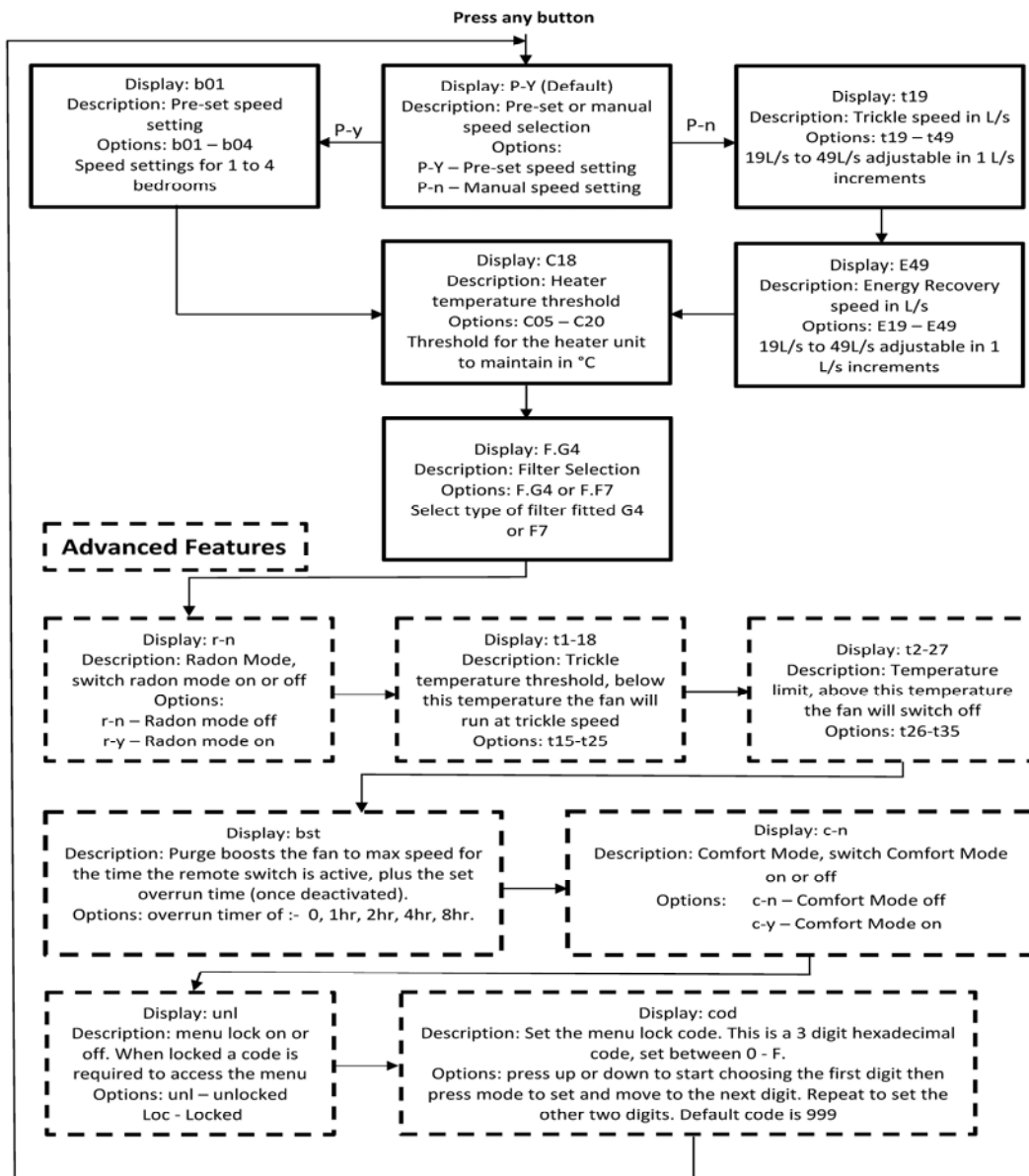

Speed Settings

The Lo-Carbon PoziDry Pro has two speed settings, 'Trickle' and 'Energy Recovery'.

- 'Trickle' speed is automatically selected when the ambient loft temperature is **below** the Trickle Speed Temperature Threshold setting. Default setting is 18°C.
- 'Energy Recovery' is automatically selected when the ambient loft temperature is between the Trickle Speed Temperature (default is 18°C) and Temperature Limit setting (default is 27°C).
- If the ambient loft temperature exceeds the Temperature Limit setting, the fan automatically switches to standby (no airflow) - except when **Radon Mode** is enabled. See Radon Mode below for more details.
- If the input air is **below -5°C** the fan will switch to standby.

There are 4 pre-set speeds that can be selected based on number of bedrooms in the property. For example, setting b03 being for a three bedroom dwelling. Please see **Fig.12** for the approximate flow rates at each setting. Alternatively, the speed settings are also fully adjustable between 19L/s and 49L/s via the manual speed setting option.

Fig. 12.		Trickle*	Energy Recovery*
No. Bedrooms	Setting	L/s	L/s
1	b01	19	29
2	b02	25	37
3	b03	31	46
4	b04	37	49

*The table shows a set up representative of a good low resistance installation using the supplied filters. When F7 filters and/or a long duct run are used it may be necessary to use the manual speed selection to meet the required flow rate.

Heater Threshold Temperature

This is the temperature at which the heater will switch on. Default is 5°C. The higher the temperature setting/threshold, the more energy the heater will use. However the lower the setting, the colder the air will be supplied into the house. The heater modulates (switches on/off) to maintain the set heater threshold temperature.

Lock feature

The **menu lock** feature will prevent the unit from being adjusted after commissioning without a pass code. This can be set in the menu to any 3 digit hexadecimal combination.

If the lock feature is enabled; when a button is pressed the display will show, – – –. At this point enter the three digit code by first pressing + or – until the first digit is correct then press MODE to move to the next digit. Repeat until the code is entered and press MODE to enter the commissioning menu. If the code is entered incorrectly, wait until the screen switches off then press any button to begin again.

Radon Mode

Radon mode keeps the fan running even at high temperatures to prevent the build-up of dangerous radon gas in the property. If this is not required, it is recommended not to use this setting.

Trickle Speed Temperature Threshold

The temperature the fan will switch from Energy Recovery Mode to Trickle mode. Usually this would be set to around 18-20°C to be slightly cooler than the normal heating thermostat temperature. Default is 18°C.

Temperature Limit

This is the maximum temperature the fan will run until going into standby. The higher the temperature the more heat will be extracted from the loft. Default is 27°C. Note that this limit is ignored in radon mode.

Comfort Mode

The comfort mode feature offsets/delays the boost when the Boost Switch has been activated until after the Boost Switch has been deactivated (up to a maximum of 20 minutes). Therefore reducing any nuisance noise until after the user has left the room.

When the Boost Switch is deactivated, fan will run at boost mode for the length of time the Boost Switch was present (up to a maximum of 20 minutes) plus the set overrun time.

If the Boost Switch was activated for less than 3 minutes, no boost will occur to prevent nuisance activations.

If the Boost Switch is still connected after 20 minutes, the fan will boost anyway. Once the Boost is disconnected, the fan will run for only 20 minutes plus the set overrun timeout.

Accessing Data Logger Menu

To access the menu of data that the unit stores press and hold the mode button for 5 seconds. The menu structure is shown below, press mode to move to the next item:

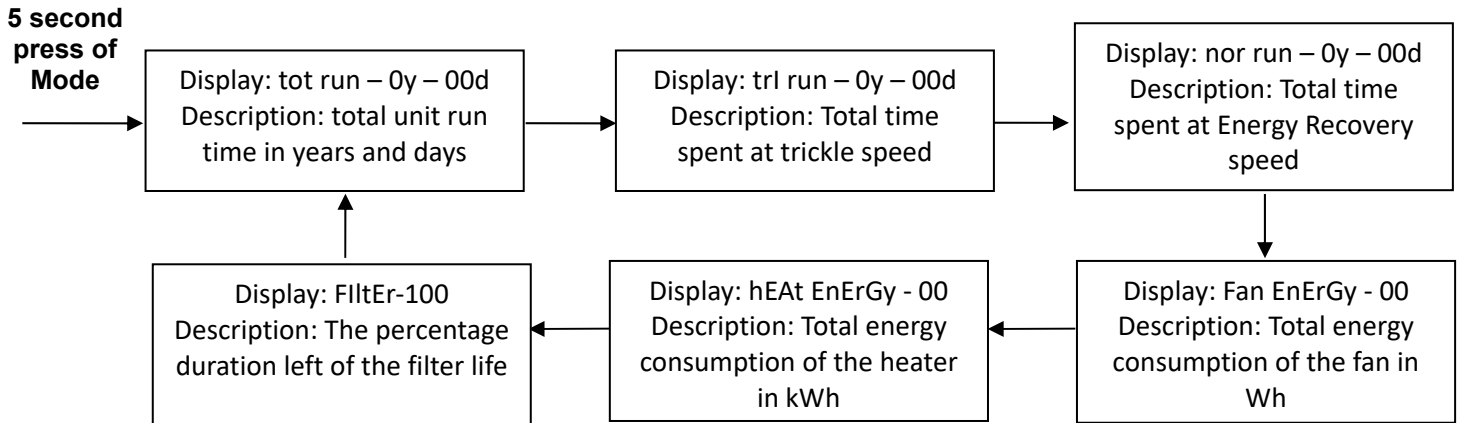

To exit the menu press **MODE** for 5 seconds or wait for the screen to switch off.

E. SERVICING AND MAINTENANCE.



WARNING: THE POSITIVE VENTILATION UNIT AND ANCILLARY CONTROL EQUIPMENT MUST BE ISOLATED FROM THE POWER SUPPLY DURING THE INSTALLATION / OR MAINTENANCE.

The fan motor uses sealed ball bearings, and does not require further lubrication. Apart from filter change the Lo-Carbon Pozidry Pro contains no user serviceable parts.

Filter: Under normal conditions; i.e. away from main roads and industrial areas, it is recommended that the filter is checked annually and cleaned or replaced as necessary. Otherwise change as required. (See Spares part list below)

The filter may be gently cleaned with a vacuum cleaner or washed in a soapy water solution and allowed to air dry before re-fitting. Do not dry the filter in a tumble dryer.

When re-fitting make sure that the filter is fitted correctly. This will ensure that all the fresh air entering the dwelling has passed through the filter first.

Below is a list of spares and accessories available for the Pozidry Pro:

Spares and Accessories	Part Number
F7 FILTER PACK	477957
1X REPLACEMENT MOUNTING LEG & FOOT	477627
HANGING KIT	477628
REPLACEMENT G4 FILTER PACK	477629
PIV TWIN SPIGOT KIT	449071
200mm DIAMETER 2m FLEXIBLE DUCTING	477748
REPLACEMENT DIFFUSER	477889
REPLACEMENT DIFFUSER FOR FD MODEL	475664
REPLACEMENT MOUNTING FOOT	478000
DIFFUSER ASSEMBLY	478228
PURGE BOOST SWITCH LINK CONNECTOR	411150

PRODUCT FICHE

For Residential Ventilation Units (Complying Commission Delegated Regulation (EU) No 1254/2014)

Name:	Vent-Axia	Vent-Axia	Vent-Axia
Model ID (Stock Ref.) :	Lo-Carbon PoziDry Pro - 476310	Lo-Carbon PoziDry Pro - 476311	Lo-Carbon PoziDry Pro - 476312
SEC Class	B	B	B
SEC Value ('Average')	28.30	28.30	28.30
SEC Value ('Warm')	12.80	12.80	12.80
SEC Value ('Cold')	55.36	55.36	55.36
Label Required? (Yes/No=Out of scope)	No	No	No
Declared as: RVU or NRVU/UVU or BVU	RVU-UVU	RVU-UVU	RVU-UVU
Speed Drive	Variable Speed	Variable Speed	Variable Speed
Type HRS (Recuperative, Regenerative, None)	None	None	None
Thermal Eff: [(%), NA(if none)]	N/A	N/A	N/A
Max. Flow Rate (m3/h)	198.00	198.00	198.00
Max. Power Input (W): (@Max.Flow Rate)	14.00	14.00 (fan only) 464 (fan with heater)	14.00 (fan only) 464 (fan with heater)
LWA: Sound Power Level (dB)	35.53	35.53	35.53
Ref. Flow Rate (m3/s)	0.04	0.04	0.04
Ref. Pressure Diff. (Pa)	N/A	N/A	N/A
SPI [W/(m3/h)]	0.09	0.09	0.09
Control Factor & Control Typology: (CTRL/ Typology)			
Control Factor; CTRL	0.65	0.65	0.65
Control Typology	Local Demand Control	Local Demand Control	Local Demand Control
Declared: -Max Internal & External Leakage Rates(%) for BVUs or carry over (for regenerative heat exchangers only), -&Ext. Leakage Rates (%) for Ducted UVUs;	N/A	N/A	N/A
Mixing Rate of Non-Ducted BVUs not intended to be equipped with one duct connection on either supply or extract air side;	N/A	N/A	N/A
Position and description of visual filter warning for RVUs intended for use with filters, including text pointing out the importance of regular filter changes for performance and energy efficiency of the unit	N/A	N/A	N/A
For UVUs (Instructions Install Regulated Supply/Extract Grilles Façade)	In F&W	In F&W	In F&W
Internet Address (for Disassembly Instructions)	www.vent-axia.com	www.vent-axia.com	www.vent-axia.com
Sensitivity p. Variation@+20/-20 Pa: (for Non-Ducted Vus)	N/A	N/A	N/A
Air Tightness-ID/OD-(m3/h) (for Non-Ducted Vus)	N/A	N/A	N/A
Annual Electricity Consumption: AEC (kWh/a)	0.46	0.46	0.46
Annual Heating Saved: AHS (kWh/a)			
AHS: Average	28.30	28.30	28.30
AHS: Warm	12.80	12.80	12.80
AHS: Cold	55.36	55.36	55.36



Disposal

This product should not be disposed of with household waste. Please recycle where facilities exist. Check with your local authority for recycling advice.

The **Vent-Axia** Guarantee

Applicable only to products installed and used in the United Kingdom. For details of guarantee outside the United Kingdom contact your local supplier.

Vent-Axia Guarantees this product for 5 years from date of purchase against faulty material or workmanship. In the event of any part being found to be defective, the product will be repaired, or at the Company's option replaced, without charge, provided that the product:-

- Has been installed and used in accordance with the instructions given with each unit.
- Has not been connected to an unsuitable electricity supply. (The correct electricity supply voltage is shown on the product rating label attached to the unit).
- Has not been subjected to misuse, neglect or damage.
- Has not been modified or repaired by any person not authorised by the company.

IF CLAIMING UNDER TERMS OF GUARANTEE

Please return the complete product, carriage paid to your original supplier or nearest Vent-Axia Centre, by post or personal visit. Please ensure that it is adequately packed and accompanied by a letter clearly marked "Guarantee Claim" stating the nature of the fault and providing evidence of date and source of purchase.

The guarantee is offered to you as an extra benefit, and does not affect your legal rights

Vent-Axia

Head Office: Fleming Way, Crawley, West Sussex, RH10 9YX.

EU Authorised Representative: Vent-Axia Sigarenmaker 5 - 5521DJ Eersel Nederland. authorisedrep@vent-axia.nl

UK NATIONAL CALL CENTRE, Newton Road, Crawley, West Sussex, RH10 9JA

SALES ENQUIRIES: Tel: 0344 8560590

TECHNICAL SUPPORT: Tel: 0344 8560594

For details of the warranty and returns procedure please refer to www.vent-axia.com or write to Vent-Axia Fleming Way, Crawley, RH10 9YX