

Vent-Axia®

Improving Indoor Air Quality since 1936

Vent-Axia Sentinel Apex



Simply more as Standard

Passivhaus Certified, Multi-Award
Winning Heat Recovery Ventilation
Units for Commercial Applications

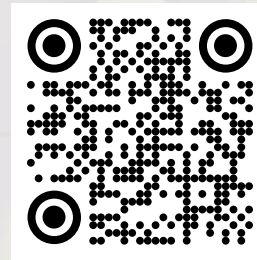

Edition 3

www.vent-axia.com/apex





HELPING YOU TO ACHIEVE YOUR SUSTAINABILITY GOALS

Addressing economic, social and environmental challenges is a priority high on everyone's agenda. The need to foster positive workplaces, achieve net-zero emissions, combat climate change and promote environmental regeneration is more urgent than ever before. Change is inevitable.

Regardless of the size of your organisation or project, we can assist you in achieving your sustainability objectives. Whether you are starting your sustainability journey or require additional support to move forward, we can help you achieve your goals in several ways.

- **Energy efficiency:** We can provide energy-efficient ventilation systems that consume less energy than traditional systems. By using less energy, you can reduce your carbon footprint and save on energy costs.
- **Sustainable materials:** We are committed to using sustainable materials in our products, such as recycled plastic and low-emission materials. By using sustainable materials, you can reduce your environmental impact.

- **Indoor air quality:** We can help improve indoor air quality by providing ventilation systems that reduce the presence of harmful pollutants and allergens in the air. This can lead to a healthier work environment for employees, which can in turn increase productivity and reduce healthcare costs
- **Life-cycle analysis:** We conduct a life-cycle analysis of our products, which includes the manufacturing, use and disposal phases. This analysis can help identify areas where the product can be made more sustainable and reduce the overall environmental impact.

Improving Indoor Air Quality, Sustainability - by choosing a Vent-Axia solution ensures you are purchasing a product designed and manufactured in the UK, reducing your environmental impact, and improving your financial performance through energy savings and improved indoor air quality.



NET ZERO COLLABORATION AWARD





EMBODIED CARBON DATA

When designing a building to be low carbon or carbon-neutral, there are many challenges to consider, from selecting materials to coordinating multiple layers of supply chain management. Obtaining accurate and up-to-date embodied carbon information is crucial for ensuring that the building meets its carbon reduction targets. However, this can be a time-consuming and complex process, as it requires data to be collected from multiple sources, including suppliers, manufacturers and contractors.

At Vent-Axia, we understand the challenges that come with designing low-carbon buildings, which is why we want to make things as easy as possible for you. We recognise that embodied carbon data can be difficult to obtain and that is why we have taken additional steps to provide accurate and reliable information.

Our Vent-Axia Sentinel Apex has been designed to have a low embodied carbon footprint. We have used the CIBSE TM65 data collection methodology to collect accurate and detailed embodied carbon information for the Sentinel Apex. This methodology ensures that our data is comprehensive, reliable and up-to-date, making it easier for you to focus on what is really important - designing buildings that are low carbon and environmentally sustainable.

By providing this valuable data, we hope to make it easier for you to design and construct buildings that are not only energy-efficient but also have a low carbon footprint. We believe that by working together, we can help to create a more sustainable built environment, one that is not only environmentally responsible but also economically and socially beneficial for all stakeholders involved.



70% sales revenue from **low-carbon products** by FY2025

90% target for **recycled plastics** for manufactured products by 2025



PASSIVHAUS CERTIFIED

We are proud to have attained Passivhaus Certification for our Sentinel Apex unit sizes HR06, HR10, HR15 and HR21. This is beneficial to customers that require the very best low-carbon heat recovery systems for their commercial buildings

Passivhaus explained:

Passivhaus is a method of creating buildings that require very little energy for heating or cooling whilst maintaining exceptional indoor comfort. It is a performance-based standard that is increasingly important to specifiers that need the lowest carbon building solutions.

A Passivhaus building typically includes:

- ✓ High quality insulation high performing insulation in walls, roofs and floors
- ✓ Airtight construction – minimising air leaks to prevent heat loss
- ✓ High-performance windows – such as triple-glazed, with insulated frames
- ✓ Mechanical ventilation with heat recovery (MVHR) – fresh air is constantly supplied while recovering heat from outgoing air via a high efficiency air to air heat exchanger
- ✓ Thermal bridge-free design – avoiding areas where heat can easily escape

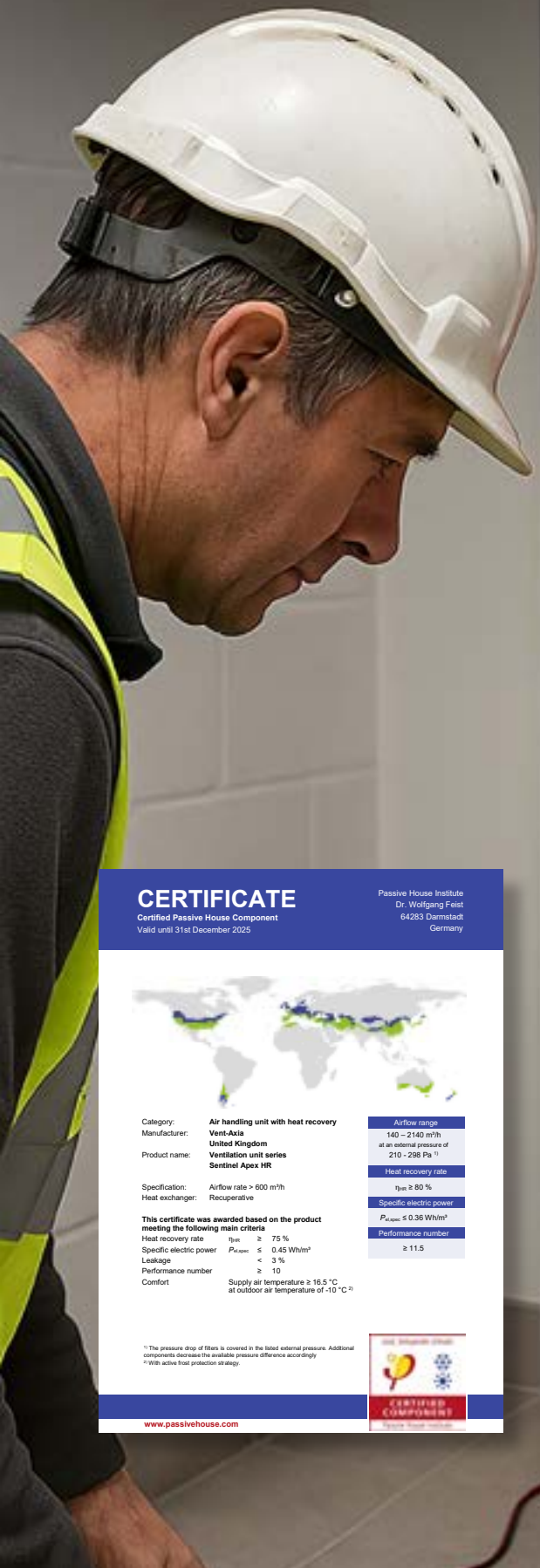

CERTIFICATE

Certified Passive House Component
Valid until 31st December 2025

Passive House Institute
Dr. Wolfgang Feist
64283 Darmstadt
Germany



Category: **Air handling unit with heat recovery**
Manufacturer: **Vent-Axia**
United Kingdom
Product name: **Ventilation unit series Sentinel Apex HR**

Specification: Airflow rate > 600 m³/h
Heat exchanger: Recuperative

This certificate was awarded based on the product meeting the following main criteria

Heat recovery rate $\eta_{\text{HR}} \geq 75\%$
Specific electric power $P_{\text{elec,spec}} \leq 0.45 \text{ Wh/m}^3$
Leakage $< 3\%$
Performance number ≥ 10
Comfort Supply air temperature $\geq 16.5^\circ\text{C}$ at outdoor air temperature of -10°C ²⁾

| | |
|--------------------------------|--|
| Airflow range | 140 – 2140 m ³ /h at an external pressure of 210 - 298 Pa ¹⁾ |
| Heat recovery rate | $\eta_{\text{HR}} \geq 80\%$ |
| Specific electric power | $P_{\text{elec,spec}} \leq 0.36 \text{ Wh/m}^3$ |
| Performance number | ≥ 11.5 |

¹⁾ The pressure drop of filters is covered in the listed external pressure. Additional components decrease the available pressure difference accordingly.
²⁾ With active frost protection strategy.



HOW PASSIVHAUS HELPS CUSTOMERS

- ✓ **High Energy Savings** – Passivhaus buildings use up to 90% less heating and cooling energy than conventional buildings, this translates to lower energy bills
- ✓ **Comfort, throughout the seasons** – consistent indoor temperatures, and excellent indoor air quality, without drafts
- ✓ **Healthier Living Environment** – MVHR systems have filters that reduce allergens and moisture reducing the risk of mold and improving the quality of the indoor air
- ✓ **Sustainability** – by reducing the energy use, Passivhaus buildings help cut carbon emissions supporting climate goals and eco-conscious living
- ✓ **Future-proofing** – with energy prices rising and cost of living a challenge, combined with stricter regulations. Passivhaus buildings are ahead of the curve, offering long-term value
- ✓ **A peaceful, quiet environment** – the insulation and airtightness also provide excellent soundproofing, and quieter equipment such as the MVHR also help to making homes quieter and more relaxing to live in, particularly in built up areas where noise can disturb your enjoyment at home

Architects, Property Developers and Building Owners are increasingly raising the standards of building design and having an energy-efficient MVHR incorporated within the building will soon be expected as standard, our Sentinel Apex range of MVHR units have won multiple awards recognising their energy efficiency benefits, advanced components and innovative design so you can be confident you have chosen an industry leading solution, designed for longevity.



THE NEED TO RECOVER ENERGY

Rising prices place an increasing pressure on organisations driving them to seek reductions in energy consumption, without adversely impacting the indoor air quality (IAQ) and thermal comfort of the building.

The high-efficiency cell incorporated within the Sentinel Apex range achieves a market leading 93% thermal efficiency (EN308 tested). This high level of efficiency means that the heating and cooling energy lost through ventilation can be reduced by up to 25% when compared to a 73% efficient heat exchanger in both heating and cooling seasons. This high efficiency also means that expensive after heaters, often required in lower efficiency heat recovery devices, may not now be required.

- ✓ High efficiency heat exchanger - up to 93% energy recovery
- ✓ Bypass designed to eliminate additional pressure loss / power consumption whilst in operation
- ✓ Integral automatic summer bypass - providing free cooling during summer
- ✓ Double skin construction for class leading acoustic properties
- ✓ Energy efficient EC/DC motors - 1/3 less energy lost to heat than a conventional AC motor
- ✓ Motor efficiency equivalent to better than IE5



THE NEED FOR BETTER INDOOR AIR QUALITY

Removal of pollutants, such as moisture, carbon dioxide and external fumes are all important factors in maintaining indoor air quality. A study cited in the new Approved Document F* indicates that CO₂ levels building up in a room can indicate poor indoor air quality (IAQ). This is why CO₂ is now recommended as a method of measuring the air quality in occupiable rooms in non-residential buildings. In addition, studies within schools have demonstrated that maintaining lower carbon dioxide levels helps create a better learning environment leading to higher student attainment. Approved Document F now states that occupied rooms in commercial buildings must have means of monitoring IAQ levels. CO₂ demand controlled ventilation can ensure good air quality as per Part F.

- ✓ Hierarchical control maintains CO₂ levels within levels described in Approved Document F Volume 2 and Building Bulletin 101
- ✓ Fully modular range of compatible air quality sensors including: CO₂, Temperature & Humidity and TVOC
- ✓ Demand control optimising indoor air quality whilst minimising ventilation energy consumption
- ✓ Closed loop control system ensures maximum comfort levels at minimum energy levels
- ✓ Class leading ultra-low sound levels exceeding requirements of Building Design

*Application of CO₂ monitoring as an approach to managing ventilation to mitigate SARS-COV-2 transmission



THE NEED TO MEET LEGISLATION

You can rest assured that when it comes to regulations, we have got all the bases covered. Our Sentinel Apex is fully compliant with both Part F and L requirements and has been specifically designed to delivery excellent performance in the energy efficiency and thermal comfort requirements of BB101 for schools.

- ✓ Meets the requirement of Approved Documents F & L 2021 edition performance and specific fan power requirements
- ✓ Market leading 93% heat exchange efficiency tested to EN 308
- ✓ Extremely low noise levels to comply with BB93 (independently tested by SRL)
- ✓ Meets the requirements for BB101 for use in schools
- ✓ Embodied carbon data and BIM Revit models available
- ✓ Lowest Specific Fan Power figures of any high efficiency D-ERV product
- ✓ With CO₂ control via nondispersive CO₂ sensors, we are able to help you achieve the new IAQ targets set out in Approved Document F



SENTINEL APEX

Simply More as Standard

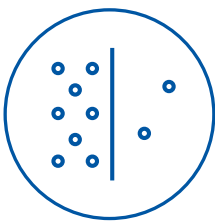

High-Spec

Removal of pollutants such as carbon dioxide and external fumes with supply filter.

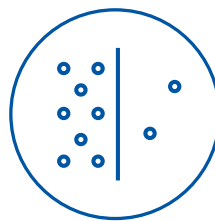

Improved IAQ

Supplying fresh, healthy, filtered air providing improved and better indoor air quality.

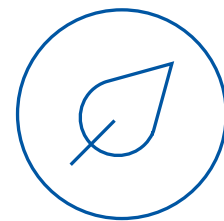

Energy Efficient

Market leading SFP's with up to 93% energy recovery.



Commercial Heat Recovery - Helping you create a low-carbon future, today.

Commercial Heat Recovery is at the forefront of offering a transformative way to embrace a low-carbon future. By harnessing wasted heat, this technology ensures that energy is not squandered but rather reused efficiently.

We work closely with clients, understanding their requirements, and designing tailored solutions that maximize efficiency and minimize environmental impact. From initial assessment to installation and ongoing maintenance, we provide comprehensive support throughout the entire process.

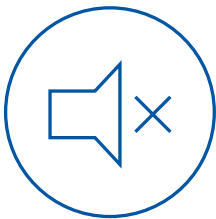

Leading SFP & Low Noise Levels

Market leading performance on SFP and double skinned panels for better sound insulation.



TM65 Embodied Carbon

Embodied carbon data available using the CIBSE TM65 data collection methodology.



Range of Sizes

Five sizes available in the range, delivering airflows up to e4000m³/h.



5-year parts warranty

Backed with a 5-year parts warranty and supported with a comprehensive spare parts list, our Sentinel Apex is designed for effortless maintenance and will stand the test of time.



SENTINEL APEX COMMERCIAL HEAT RECOVERY RANGE

The Sentinel Apex range is the next generation in commercial heat recovery systems. Designed to supply the indoor environment with fresh, healthy, filtered air providing improved air quality, while maintaining exceptional energy recovery, market leading Specific Fan Power (SFP) and low noise levels.

With five sizes in the range, delivering airflows up to 4000m³/h, there is a solution for all your project requirements. In various settings such as schools, offices, hotels and restaurants, the focus is on enhancing indoor air quality and comfort for the well-being of the occupants, while also aiming to reduce energy consumption and lower running costs.

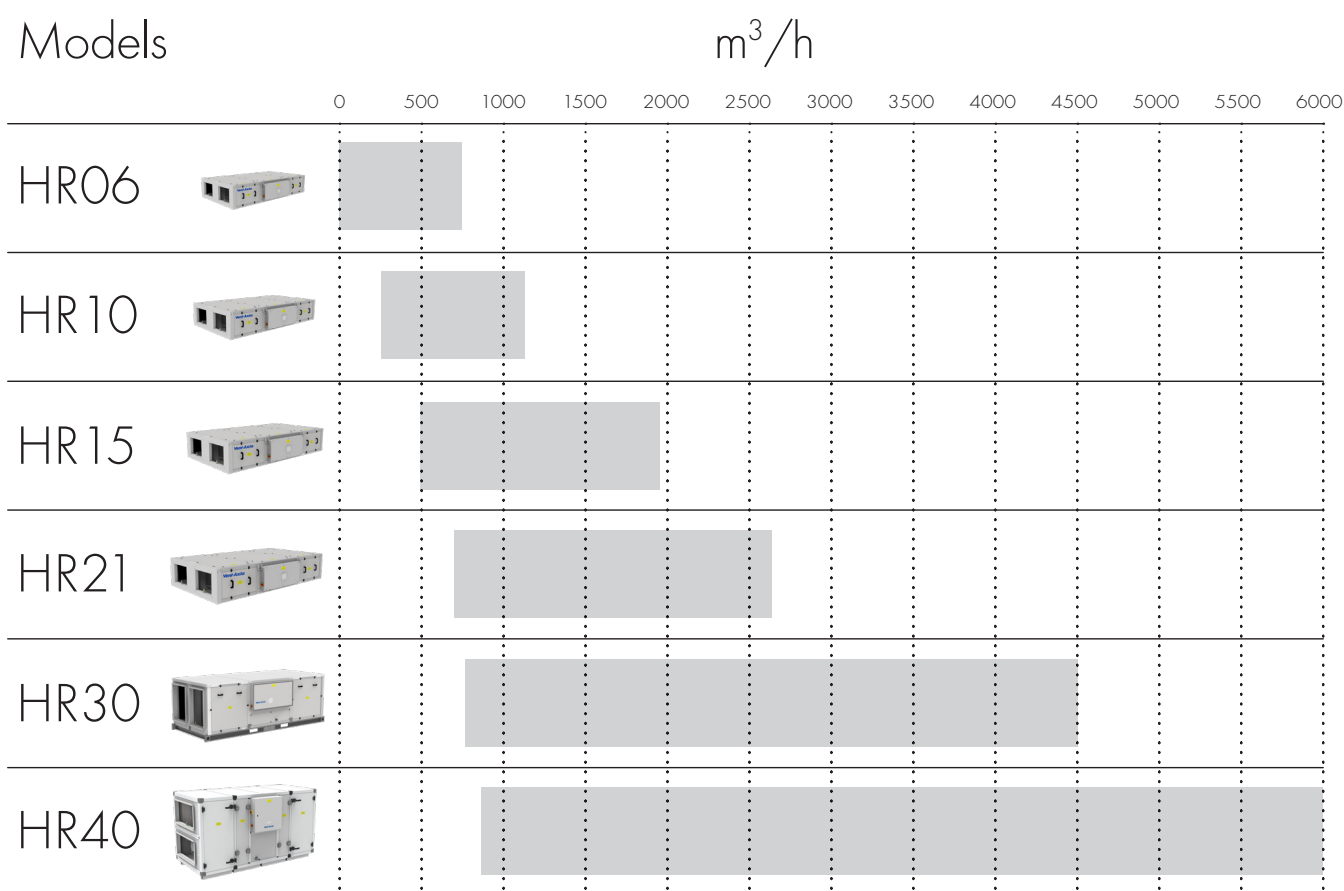

What is Heat Recovery?

Heat Recovery Ventilation units also known as Mechanical Ventilation Heat Recovery (MVHR) are supply and extract systems which are the ideal solution where the need to recover energy and supply the indoor environment with fresh, healthy, filtered air while extracting stale air.

Heat recovery systems typically recover about 60-95% of the heat in exhaust air and have significantly improved the energy efficiency of buildings, we can offer low-energy solutions for every commercial application, all manufactured in the UK to the highest standards.

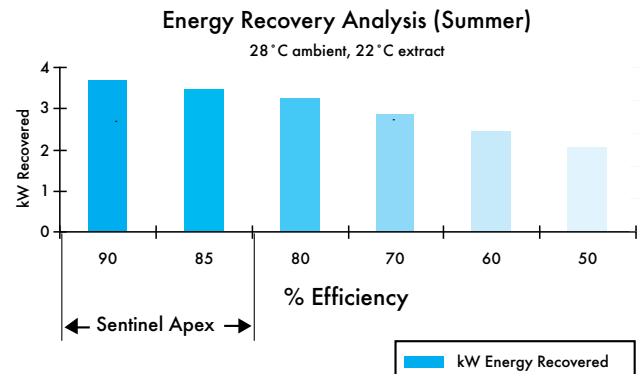
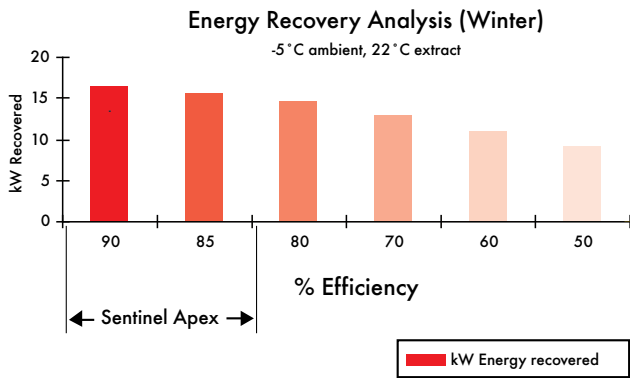
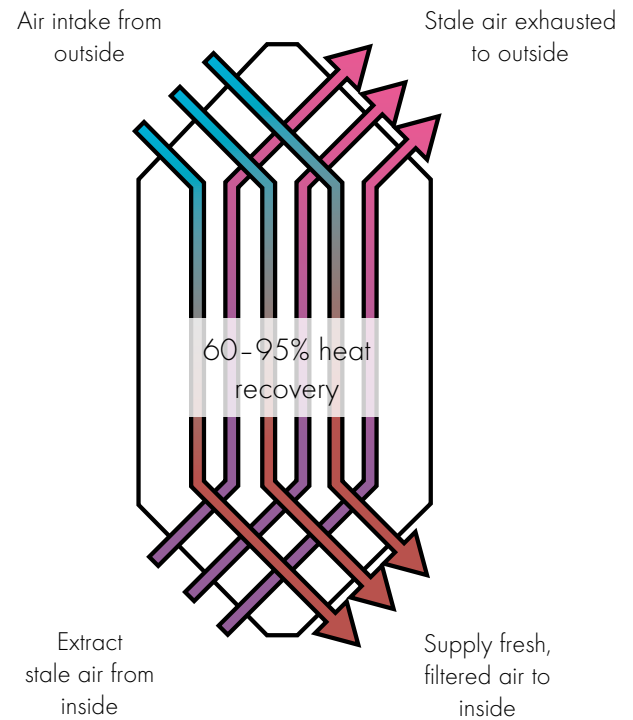

| Airflow m ³ /s | Efficiency % | kW Heat recovered | Supply temp °C |
|------------------------------|--------------|----------------------|-------------------|
| 0.555 | 90 | 16.51 | 19.3 |
| | 85 | 15.59 | 18.0 |
| | 80 | 14.67 | 16.6 |
| | 70 | 12.84 | 13.9 |
| | 60 | 11.00 | 11.2 |
| | 50 | 9.17 | 8.5 |

| Airflow m ³ /s | Efficiency % | kW Cool Recovered | Supply temp °C |
|------------------------------|--------------|----------------------|-------------------|
| 0.555 | 90 | 3.67 | 22.6 |
| | 85 | 3.46 | 22.9 |
| | 80 | 3.26 | 23.2 |
| | 70 | 2.85 | 23.8 |
| | 60 | 2.45 | 24.4 |
| | 50 | 2.04 | 25.0 |



VERSATILE APPLICATION

Ideal for applications where the rooms are used at different times of the day by a variable number of people, the Sentinel Apex system will monitor occupancy, ventilation rate and air quality, and respond accordingly to maintain the atmosphere within preset limits, recovering up to 93% of extracted energy.

Typical applications include:

- ✓ A network of hotel bathrooms, flats or apartments, which require ventilation but are only used for limited periods particularly in the morning and evening.
- ✓ School classrooms and lecture theatres, which are only occupied during lesson time by a variable number of students, but when used must keep CO₂ levels within prescribed limits.
- ✓ Office meeting rooms or open plan areas which, are used periodically during the day by a variable number of staff and visitors, but when occupied must meet required airflow rates.

Automatic sensing and control runs the system according to the maximum demand requirements of the building zone, whether it be carbon dioxide levels, temperature, humidity or air quality - triggered by people entering or leaving the rooms. Common configurations include Electronic Static Pressure (ESP) controllers for constant pressure systems.





Compliant with Part F & L of the Building Regulations



Compliant with BB101



Compliant with the schools outputs specifications, 2F & 2J



Compliant with PPN 06/21

Carbon Dioxide Guidance

Studies have shown that CO₂ can be harmful to health, as well as reducing focus and attention. This can be especially damaging to students, when in a classroom of up to 32 people or in small office spaces with a high number of staff. If ventilation is not sufficient, the CO₂ levels can rise quickly. In BB101 guidance, an average of 1000PPM is required to be maintained when mechanical ventilation is installed providing a healthy environment for students, teachers and office staff.

The Vent-Axia Sentinel Apex can provide closed loop CO₂ control to maintain levels below the required targets from the BB101 guidance.

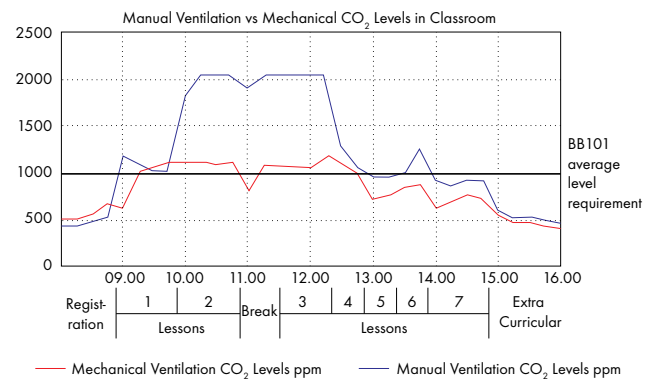

MECHANICAL SYSTEM OVERVIEW

Access Points

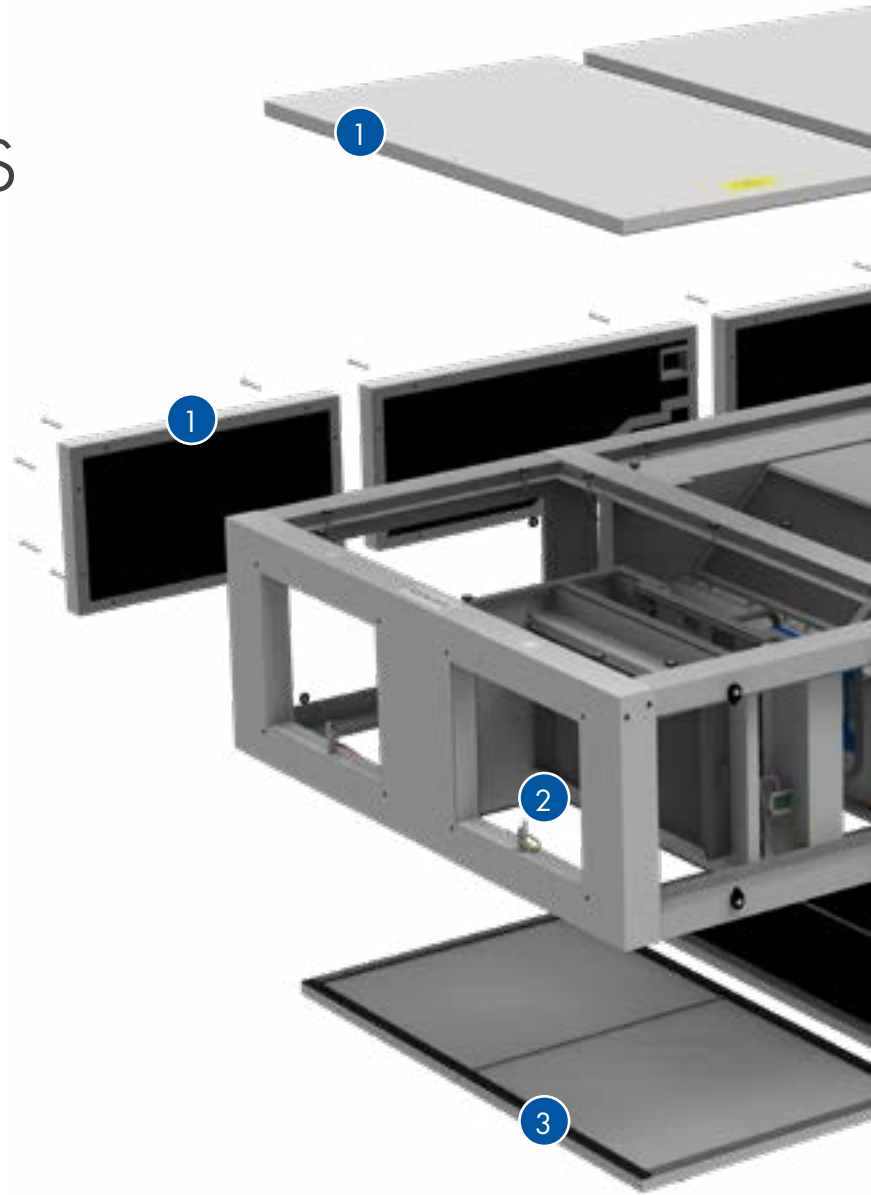

1

Top and Side Panels

Top and reverse side panel fixed, but can be removed for full access to all internal components.

2

Extract Air Filter

ePM10 50% (M5 equivalent) extract filter.

3

Bottom Panels

Bottom access panels removable for filter and motor access.

4

Fitted Isolator

Fitted lockable mains isolator.

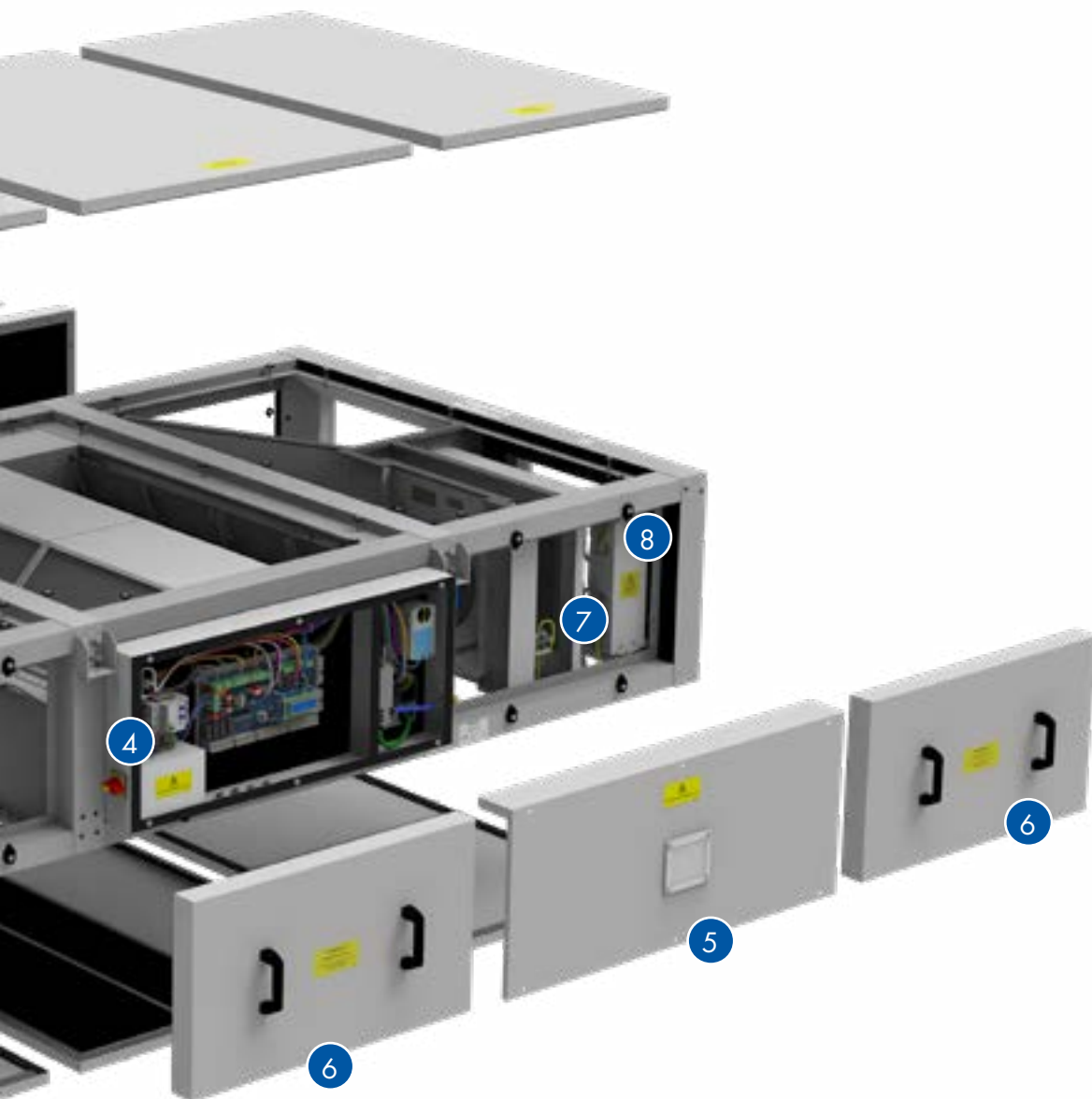

5

Control Cover

Removal cover for wiring control panel accessible without removing panel.

6

Side Panels

Removable side access panels for filter and motor access.

7

Supply Air Filter

ePM1 55% (F7 equivalent) supply filter.

8

Anti-Frost Heater

Integral electric anti-frost heater.

MECHANICAL SYSTEM OVERVIEW

Mechanical Accessories

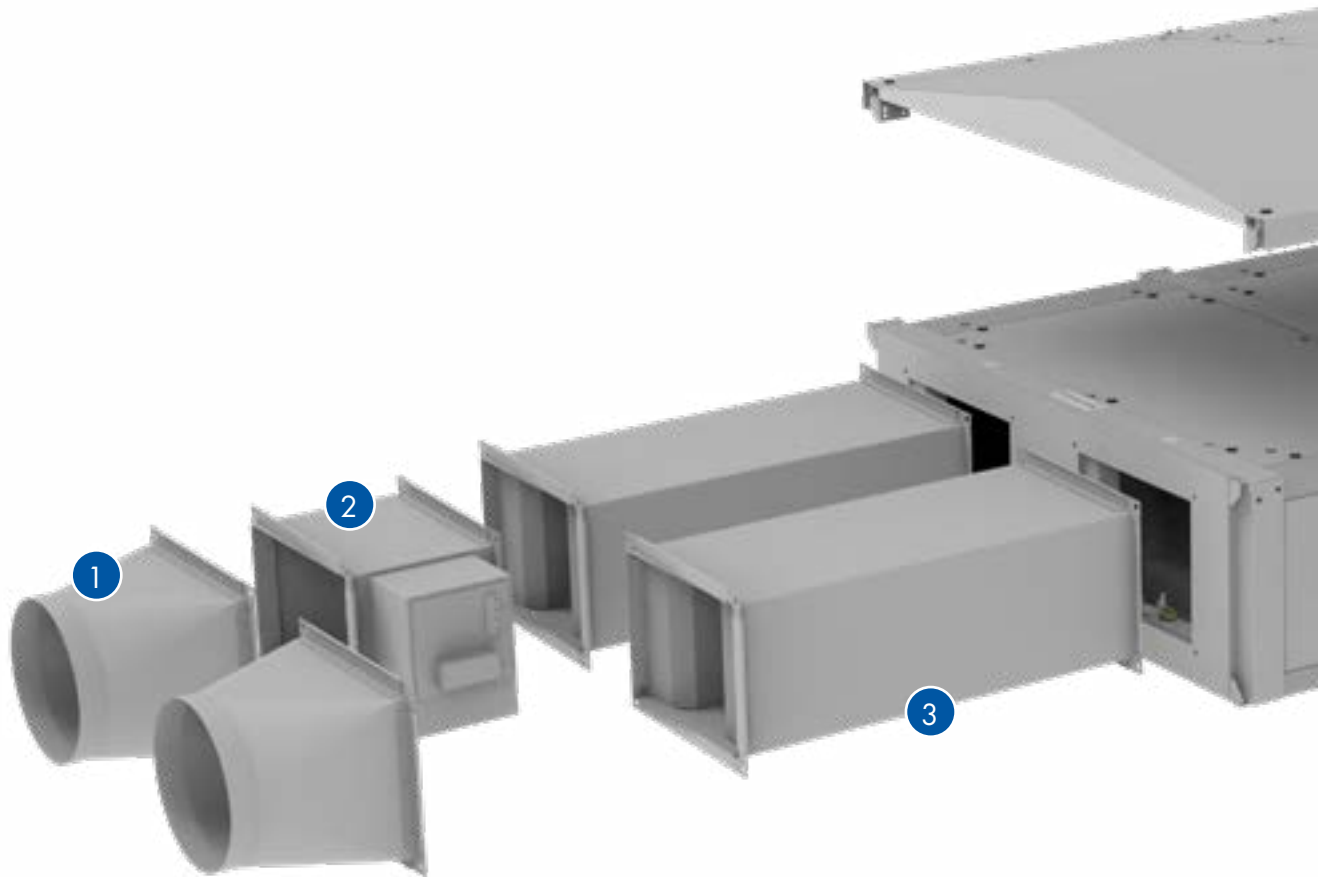

1 Rectangular to Round

Rectangular to round transformation piece to allow fitting to standard circular ducting.

2 Heater and Cooler Section

Rectangular Duct mounted heater battery with either electric heating complete with integral thyristor controls, or LPHW water heating. Each are designed to provide approximately 10°C temperature rise. Chilled water cooler also available with integral condensate tray. Note, waterside controls are not included.

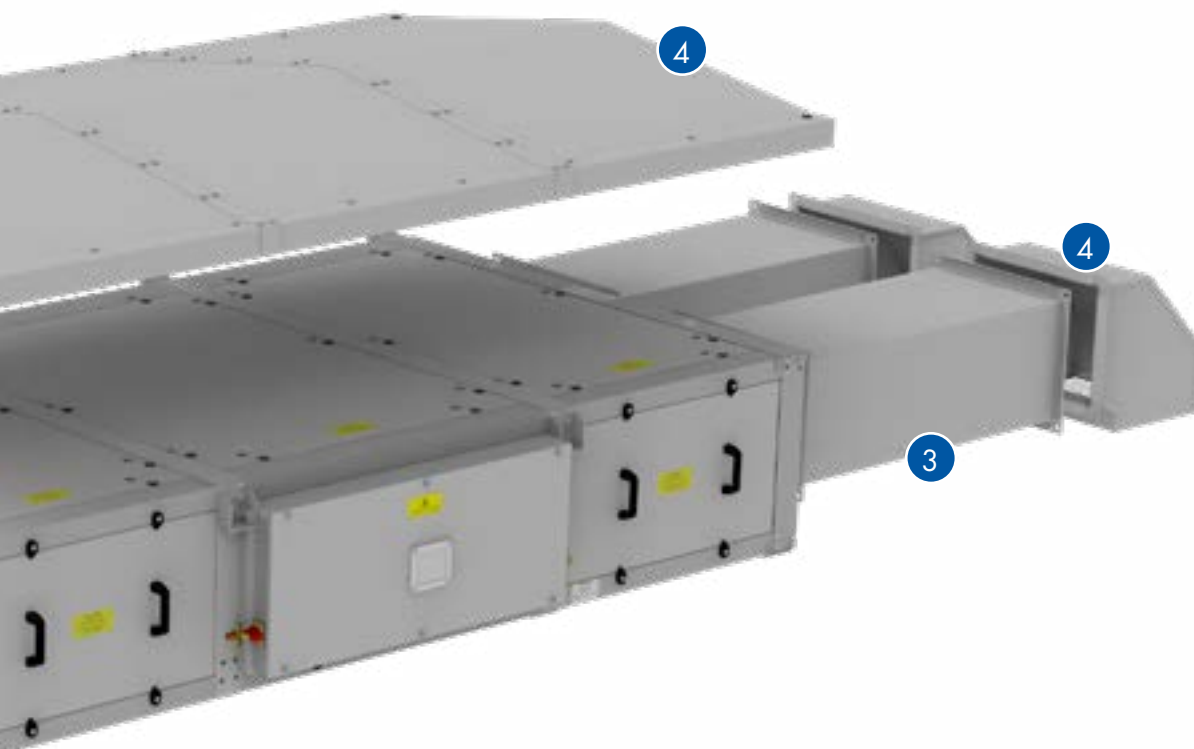

3 Duct Attenuators

Single-skinned attenuators purpose designed for the Sentinel Apex heat recovery range to minimise in duct noise. Attenuators are supplied in standard lengths of 900mm, 1200mm and 1500mm, constructed from Galvanised steel with profiled perforated sheet internal, mineral wool sound absorbing material and 30mm profiled flanges for duct and unit mounting.

4 Roof and Cowls

Optional weather roof and inlet/discharge cowls for external mounting. Pitched weather roof for externally mounted units, supplied in sections for fitting to the unit on site. Inlet/discharge cowl for external mounting minimising any ingress of water to the unit. Supplied loose from the unit and as individual items for fitting on site either to the unit or a duct section/attenuator.

Sentinel Apex HR06

- Passivhaus Certified
- Very low sound levels independently tested and verified by SRL
- Low SFP utilising IE 5 equivalent motors
- High Heat Recovery Efficiency – up to 93% (EN308)
- Automatic summer bypass sized to eliminate performance loss
- ePM10 50% and ePM1 55% filters as standard (M5 / F7 equivalent)
- Filter access from bottom and side as standard
- Digital on board controller and remote room controller as standard
- App connectivity as standard
- Wired and Wireless communication sensors available
- Integral condensate tray and pump
- Electric frost protection heater as standard

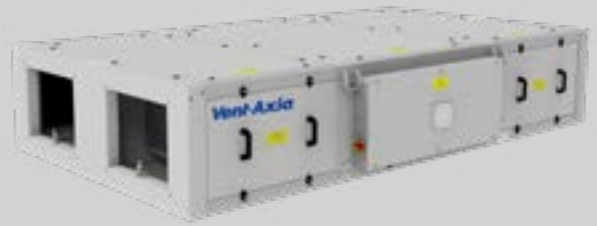

Passivhaus

Passivhaus MVHR is a critical part of a Passivhaus project and its success in driving down energy usage. The performance of the MVHR system is considered an integral element of the primary Passivhaus heating demand calculation. Vent-Axia's range of commercial MVHRs can support you with your next Passivhaus project with our most advanced MVHR systems available with wired or wireless sensors and controls. Our Passivhaus certified MVHRs provide up to 80% Thermal Efficiency, while providing an industry leading performance number of ≥ 11.5 .

Vent-Axia's commercial MVHR offers free cooling through an Intelligent Summer Bypass during the warmer months, contains F7/M5 filters as standard, along with option of the MVHR to provide Demand Controlled Ventilation, Constant Pressure or Constant Volume meaning you will have full control over your indoor environment. The MVHRs include internal frost protection pre-heaters, meaning you will achieve the best thermal comfort possible at all times.

Performance simply delivered with more as standard

Vent-Axia's Sentinel Apex range of commercial heat recovery units with up to 93% EN308 heat recovery efficiency, low sound levels and low specific fan powers the range provides high levels of performance efficiently. A new advanced control system that provides on board control, in room control and App based control full functionality commissioning and monitoring is simply provided. This control can be coupled with Vent-Axia's new range of sensors with wired or wireless communication providing close control of, and monitoring of your indoor air quality. Sensors include CO₂, humidity and temperature and provide both proportional and switch control.

The Sentinel Apex HR06 unit is manufactured with a double skinned pentapost construction incorporating aluzinc frames and panels. The panels are acoustically and thermally treated with 90kg/m³ high efficiency acoustic and thermally insulating foam (fire retardant to BS476 Part 7 Class 1 & Part 6 Class O). The construction of the unit, IPX4, allows for internal and external mounting as standard, however, the roof assembly should be included for full external locations.

The housing is designed to be as compact as possible for concealed false ceiling applications with top and bottom access panels for maintenance. Access panels are sized to enable single person maintenance.

The fans utilised in the Sentinel Apex HR06 are the latest EC/DC external rotor motors specifically chosen for their low power consumption and low noise characteristics. The assembly is dynamically balanced to DIN ISO 1940 Grade 6.3. Ball bearings are greased for life. Insulation is Class 'B' (from -25°C to +60°C). All models incorporate internal electronic overload protection and a soft start function.

The Sentinel Apex HR06 is complete as standard with ISO ePM10 50% (M5) extract filter and ISO ePM1 55% (F7) supply, complete with a filter change warning. Filters have been selected to fully comply with the requirements of ISO16890 whilst having low pressure loss characteristics.

An integral electric frost heater is included to provide frost protection of the cell and filters down to -10°C.

The unit is complete with an integral summer bypass facility which has been designed to provide full bypass without impact to the airflow or power consumption of the unit whilst in bypass mode.

Airflow and power consumption tested in accordance with BS EN 5801. Sound data derived from independent testing at Sound Research Laboratories in accordance with EN ISO 3741:2010. Published dB(A) figures are free field sound pressure levels at 3m with spherical propagation at a reference level of 2×10^{-5} Pa. The inlet/outlet sound power level spectra figures are dB with a reference of 10^{-12} watts.

An integral condensate tray is fitted along with an internal quiet running high quality pump allowing for removal of the condensate via a 10mm condensate pipe.

To facilitate normal access and maintenance to the unit there are both side and bottom access panels as standard. Should it be required, all panels are removable allowing access and removal of the heat recovery cell and all other components. A lockable isolator is fitted to the control panel preventing accidental operation whilst any maintenance is being carried out.

The electrical supply for the unit is 230V +/- 10% / 50/60Hz / 1ph. A 24V DC power is available from the unit for powering any of the matched sensors and switches.

The Sentinel Apex HRO6 unit is fitted with an integrated control system as standard with a purpose designed user interface controller incorporating an alphanumeric 2 line display with 4 button keypad for fan status and a basic commissioning setup mounted within the control panel. A remote HMI is also included for that can be mounted within the room that is being ventilated. This allows for local monitoring of the unit along with the commissioning set-up.

A full range of sensors is available including humidity, temperature and CO₂ monitoring. These sensors are available for both wired and wireless communication with the wireless sensors being either local mains or battery powered.

App based control is also available via the Vent-Axia Connect App. This provides detailed commissioning and monitoring information and the ability to control the unit remotely.

Model **Sentinel Apex HRO6** Stock Ref **HRO6X**

Dimensions (mm)

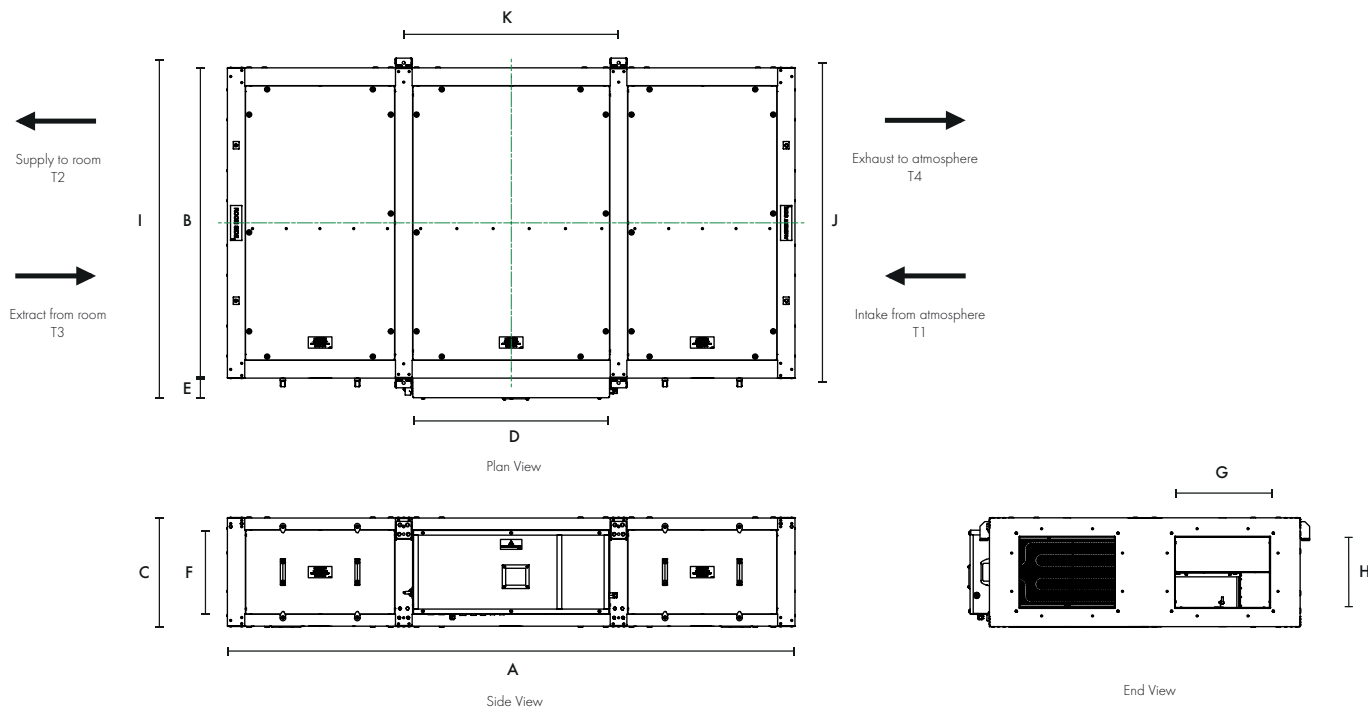

| A (LENGTH) | B (WIDTH) | C (HEIGHT) | D | E | F | G | H | I | J | K | kg |
|------------|-----------|------------|-----|----|-----|-----|-----|------|------|-----|-----|
| 2141 | 1323 | 350 | 719 | 89 | 248 | 400 | 200 | 1450 | 1363 | 791 | 275 |

Heat Recovery Efficiency

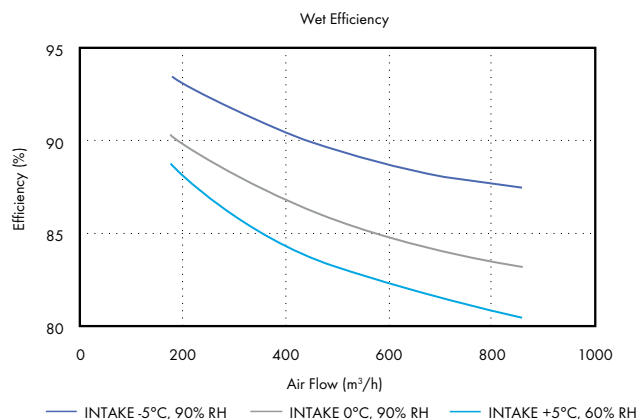
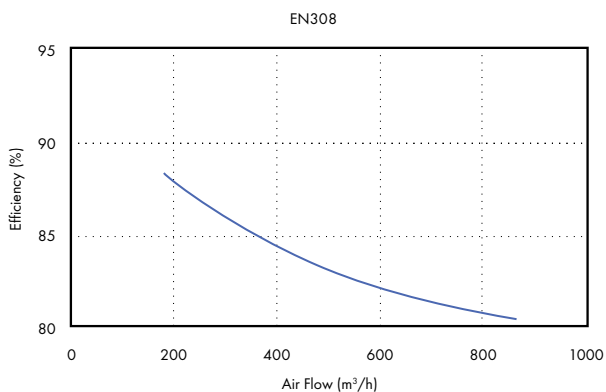

Performance Guide - Sentinel Apex HR06

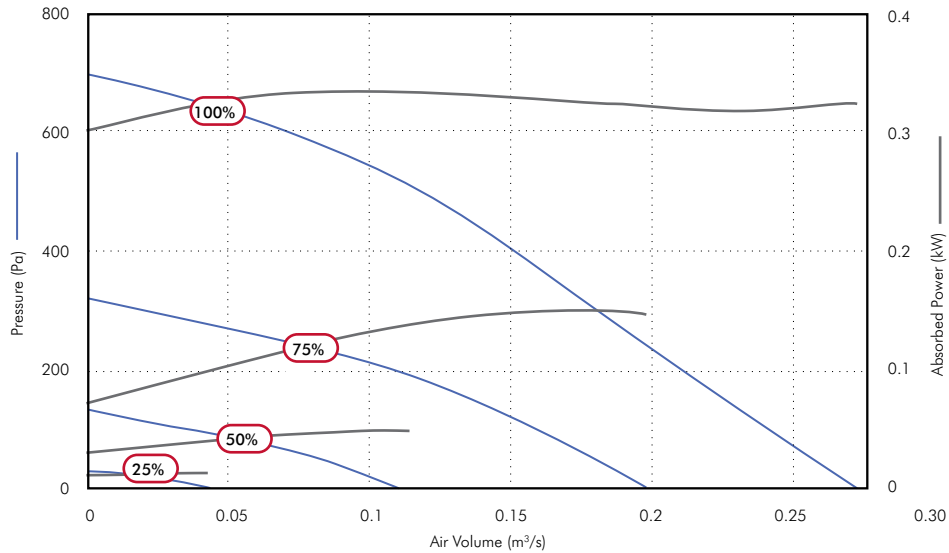

| Speed | Airflow, m³/s @ Pa | | | | | | | | | | | Fans F.L.C. | Supply Voltage | Frost Heater | Unit Rated Current | |
|-------|--------------------|-------|-------|-------|-------|-------|-------|-------|-------|-------|-------|----------------|-------------------|-----------------|-----------------------|--|
| | 0 | 25 | 50 | 100 | 150 | 200 | 250 | 300 | 400 | 500 | | | | | | |
| 100% | m³/s | 0.27 | 0.27 | 0.26 | 0.24 | 0.22 | 0.21 | 0.19 | 0.18 | 0.15 | 0.12 | 1.5A | 230/1/50 | 2.4kW | 12A | |
| | SFP | 1.19 | 1.21 | 1.25 | 1.34 | 1.42 | 1.51 | 1.67 | 1.82 | 2.19 | 2.78 | | | | | |
| | kW | 0.323 | 0.320 | 0.320 | 0.318 | 0.318 | 0.318 | 0.320 | 0.323 | 0.334 | 0.334 | | | | | |
| 75% | m³/s | 0.20 | 0.19 | 0.18 | 0.16 | 0.13 | 0.11 | 0.07 | | | | | | | | |
| | SFP | 0.73 | 0.77 | 0.84 | 0.93 | 1.07 | 1.23 | 1.66 | | | | | | | | |
| | kW | 0.144 | 0.145 | 0.147 | 0.147 | 0.143 | 0.132 | 0.116 | | | | | | | | |
| 50% | m³/s | 0.11 | 0.10 | 0.08 | 0.04 | | | | | | | | | | | |
| | SFP | 0.41 | 0.47 | 0.55 | 0.95 | | | | | | | | | | | |
| | kW | 0.045 | 0.045 | 0.044 | 0.036 | | | | | | | | | | | |
| 25% | m³/s | 0.04 | 0.01 | | | | | | | | | | | | | |
| | SFP | 0.012 | 0.27 | | | | | | | | | | | | | |
| | kW | 0.011 | 1.06 | | | | | | | | | | | | | |

Sound Data - Sentinel Apex HR06

| Speed | Test Mode | Sound Pressure level @ 3.0m dBA | | | | | | | | |
|-------|------------|---------------------------------|-----|-----|-----|----|----|----|----|----|
| | | 63 | 125 | 250 | 500 | 1k | 2k | 4k | 8k | |
| 100% | Breakout | 58 | 54 | 56 | 48 | 46 | 43 | 35 | 29 | 32 |
| | Exhaust T4 | 58 | 55 | 61 | 54 | 54 | 54 | 46 | 36 | |
| | Extract T3 | 64 | 64 | 72 | 64 | 56 | 56 | 55 | 48 | |
| | Intake T1 | 64 | 64 | 71 | 63 | 57 | 56 | 55 | 48 | |
| | Supply T2 | 58 | 54 | 59 | 53 | 53 | 54 | 46 | 36 | |
| 75% | Breakout | 53 | 52 | 54 | 40 | 39 | 36 | 29 | 23 | 27 |
| | Exhaust T4 | 52 | 50 | 52 | 47 | 46 | 47 | 39 | 28 | |
| | Extract T3 | 60 | 59 | 68 | 54 | 48 | 48 | 47 | 40 | |
| | Intake T1 | 59 | 59 | 67 | 55 | 50 | 49 | 47 | 39 | |
| | Supply T2 | 52 | 50 | 54 | 46 | 47 | 48 | 39 | 28 | |
| 50% | Breakout | 46 | 51 | 38 | 30 | 28 | 26 | 25 | 21 | 17 |
| | Exhaust T4 | 45 | 55 | 41 | 36 | 35 | 35 | 26 | 23 | |
| | Extract T3 | 53 | 64 | 53 | 44 | 37 | 36 | 34 | 26 | |
| | Intake T1 | 54 | 68 | 53 | 44 | 39 | 37 | 34 | 26 | |
| | Supply T2 | 45 | 49 | 41 | 35 | 35 | 36 | 26 | 24 | |
| 25% | Breakout | 40 | 35 | 30 | 17 | 19 | 16 | 22 | 21 | 9 |
| | Exhaust T4 | 38 | 32 | 27 | 21 | 19 | 17 | 18 | 23 | |
| | Extract T3 | 44 | 43 | 35 | 28 | 20 | 18 | 19 | 23 | |
| | Intake T1 | 44 | 40 | 35 | 27 | 21 | 18 | 18 | 23 | |
| | Supply T2 | 37 | 32 | 27 | 21 | 19 | 18 | 19 | 24 | |

For full sound and performance data please use our Fan Selection Program www.vent-axia.com/fanselector/product/apex
 Sound data derived from independent testing at Sound Research Laboratories in accordance with EN ISO 3741:2010. Published dB(A) figures are free field sound pressure levels at 3m with spherical propagation at a reference level of 2×10^{-5} Pa. The inlet/outlet sound power level spectra figures are dB with a reference of 10^{-12} watts.

Accessories

Attenuator



Single skinned attenuators purpose designed for the Apex Heat Recovery range to minimise in duct noise. Attenuators are supplied in standard lengths of 900mm, 1200mm and 1500mm, constructed from Galvanised steel with profiled perforated sheet internal, mineral wool sound absorbing material and 30mm profiled flanges for duct and unit mounting. Data has been obtained by testing in accordance with BS EN ISO7235:2009.

| Stock Ref. | Dimensions (mm) | | | kg | Insertion Loss dB | | | | | | | | m ³ /hr @ Pa | | |
|--------------|-----------------|-------|--------|----|-------------------|----|-----|-----|-----|----|----|----|-------------------------|-----|-----|
| | Length | Width | Height | | Weight | 63 | 125 | 250 | 500 | 1k | 2k | 4k | 8k | 300 | 600 |
| ATT900-HR06 | 900 | 400 | 200 | 17 | 2 | 5 | 11 | 19 | 33 | 39 | 31 | 24 | 8 | 30 | 83 |
| ATT1200-HR06 | 1200 | 400 | 200 | 21 | 3 | 6 | 14 | 26 | 43 | 45 | 35 | 27 | 8 | 33 | 92 |
| ATT1500-HR06 | 1500 | 400 | 200 | 31 | 4 | 7 | 18 | 32 | 52 | 52 | 38 | 30 | 9 | 37 | 103 |

Duct mounted Heating / Cooling



Rectangular duct mounted heater battery with either electric heating complete with integral thyristor controls, or LPHW water heating, each designed to provide approximately 10°C temperature rise. Chilled water cooler also available with integral condensate tray. Note waterside controls are not included.

| Stock Ref. | Type | Dimensions (mm) | | | kg | Heater rating kW | Electrical supply | Water Temp | | | m ³ /hr @ Pa | | |
|------------|---|-----------------|-------|--------|----|------------------|-------------------|------------|------|--------|-------------------------|-----|-----|
| | | Length | Width | Height | | | | Weight | Flow | Return | Connection | 300 | 600 |
| EHB-HR06 | HR 6 Duct mounted Rectangular electric heater with controls | 300 | 400 | 200 | 5 | 2.00 | 230/1/50 | N/A | N/A | N/A | 8 | 33 | 92 |
| HWB-HR06 | HR 6 Duct mounted Rectangular LPHW heating battery | 200 | 400 | 200 | 5 | 2.01 | N/A | 80°C | 60°C | 1/2" | 8 | 33 | 92 |
| CWB-HR06 | HR 6 Duct mounted Rectangular water cooling battery | 200 | 400 | 200 | 5 | 2.52 | N/A | 6°C | 12°C | 3/4" | 8 | 33 | 92 |

Roof Assembly

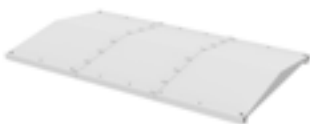

Pitched roof for external mounting, supplied separate for fitting on site.

| Stock Ref | Length mm | Width mm | Height mm | Weight kg |
|-----------|-----------|----------|-----------|-----------|
| WRF-HR06 | 2141 | 1455 | 95 | 48 |

Intake / Exhaust Cowl



Weather inlet/discharge cowl for external mounting (one required for each airstream).

| Stock Ref | Length mm | Width mm | Height mm | Weight kg |
|-----------|-----------|----------|-----------|-----------|
| 497218 | 294 | 402 | 274 | 4 |

Transformation Piece



Rectangular to round transformation piece designed to fix directly to the unit or any of the specific HR06 duct accessories to enable connection to 250mm round ducting.

| Stock Ref | Length mm | Width mm | Height mm | Weight kg |
|-----------|-----------|----------|-----------|-----------|
| 497222 | 250 | 400 | 200 | 3 |

Flexible Connection



| Stock Ref | Length mm | Width mm | Height mm | Weight kg |
|-----------|-----------|----------|-----------|-----------|
| 497018 | 130 | 400 | 200 | 3 |

Sentinel Apex HR10

- Passivhaus Certified
- Very low sound levels independently tested and verified by SRL
- Low SFP utilising IE 5 equivalent motors
- High Heat Recovery Efficiency – up to 93% (EN308)
- Automatic summer bypass sized to eliminate performance loss
- ePM10 50% and ePM1 55% filters as standard (M5 / F7 equivalent)
- Filter access from bottom and side as standard
- Digital on board controller and remote room controller as standard
- App connectivity as standard
- Wired and Wireless communication sensors available
- Integral condensate tray and pump
- Electric frost protection heater as standard

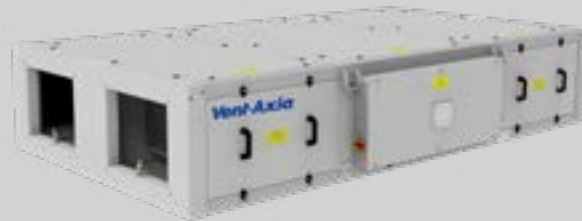

Passivhaus

Passivhaus MVHR is a critical part of a Passivhaus project and its success in driving down energy usage. The performance of the MVHR system is considered an integral element of the primary Passivhaus heating demand calculation. Vent-Axia's range of commercial MVHRs can support you with your next Passivhaus project with our most advanced MVHR systems available with wired or wireless sensors and controls. Our Passivhaus certified MVHRs provide up to 80% Thermal Efficiency, while providing an industry leading performance number of ≥ 11.5 .

Vent-Axia's commercial MVHR offers free cooling through an Intelligent Summer Bypass during the warmer months, contains F7/M5 filters as standard, along with option of the MVHR to provide Demand Controlled Ventilation, Constant Pressure or Constant Volume meaning you will have full control over your indoor environment. The MVHRs include internal frost protection pre-heaters, meaning you will achieve the best thermal comfort possible at all times.

Performance simply delivered with more as standard

Vent-Axia's Sentinel Apex range of commercial heat recovery units with up to 93% EN308 heat recovery efficiency, low sound levels and low specific fan powers the range provides high levels of performance efficiently. A new advanced control system that provides on board control, in room control and App based control full functionality commissioning and monitoring is simply provided. This control can be coupled with Vent-Axia's new range of sensors with wired or wireless communication providing close control of, and monitoring of your indoor air quality. Sensors include CO₂, humidity and temperature and provide both proportional and switch control.

The Sentinel Apex HR10 unit is manufactured with a double skinned pentapost construction incorporating aluzinc frames and panels. The panels are acoustically and thermally treated with 90kg/m³ high efficiency acoustic and thermally insulating foam (fire retardant to BS476 Part 7 Class 1 & Part 6 Class O). The construction of the unit, IPX4, allows for internal and external mounting as standard, however, the roof assembly should be included for full external locations.

The housing is designed to be as compact as possible for concealed false ceiling applications with top and bottom access panels for maintenance. Access panels are sized to enable single person maintenance.

The fans utilised in the Sentinel Apex HR10 are the latest EC/DC external rotor motors specifically chosen for their low power consumption and low noise characteristics. The assembly is dynamically balanced to DIN ISO 1940 Grade 6.3. Ball bearings are greased for life. Insulation is Class 'B' (from -25°C to +60°C). All models incorporate internal electronic overload protection and a soft start function.

The Sentinel Apex HR10 is complete as standard with ISO ePM10 50% (M5) extract filter and ISO ePM1 55% (F7) supply, complete with a filter change warning. Filters have been selected to fully comply with the requirements of ISO 16890 whilst having low pressure loss characteristics.

An integral electric frost heater is included to provide frost protection of the cell and filters down to -10°C.

The unit is complete with an integral summer bypass facility which has been designed to provide full bypass without impact to the airflow or power consumption of the unit whilst in bypass mode.

Airflow and power consumption tested in accordance with BS EN 5801. Sound data derived from independent testing at Sound Research Laboratories in accordance with EN ISO 3741:2010. Published dB(A) figures are free field sound pressure levels at 3m with spherical propagation at a reference level of 2×10^{-5} Pa. The inlet/outlet sound power level spectra figures are dB with a reference of 10^{-12} watts.

An integral condensate tray is fitted along with an internal quiet running high quality pump allowing for removal of the condensate via a 10mm condensate pipe.

To facilitate normal access and maintenance to the unit there are both side and bottom access panels as standard. Should it be required, all panels are removable allowing access and removal of the heat recovery cell and all other components. A lockable isolator is fitted to the control panel preventing accidental operation whilst any maintenance is being carried out.

The electrical supply for the unit is 230V +/- 10% / 50/60Hz / 1ph. A 24V DC power is available from the unit for powering any of the matched sensors and switches.

The Sentinel Apex HR10 unit is fitted with an integrated control system as standard with a purpose designed user interface controller incorporating an alphanumeric 2 line display with 4 button keypad for fan status and a basic commissioning setup mounted within the control panel. A remote HMI is also included for that can be mounted within the room that is being ventilated. This allows for local monitoring of the unit along with the commissioning set-up.

A full range of sensors is available including humidity, temperature and CO₂ monitoring. These sensors are available for both wired and wireless communication with the wireless sensors being either local mains or battery powered.

App based control is also available via the Vent-Axia Connect App. This provides detailed commissioning and monitoring information and the ability to control the unit remotely.

Model Sentinel Apex HR10
Stock Ref HR10X

Dimensions (mm)

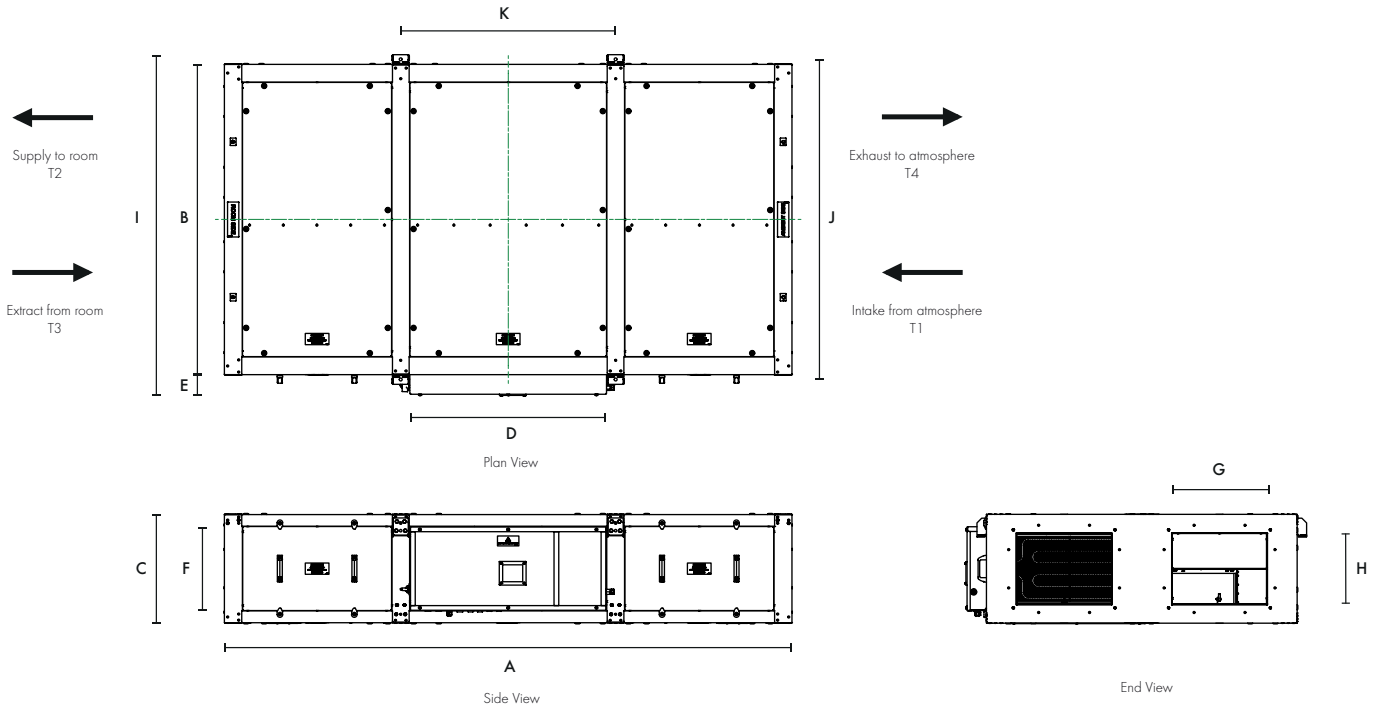

| A (LENGTH) | B (WIDTH) | C (HEIGHT) | D | E | F | G | H | I | J | K | kg |
|------------|-----------|------------|-----|----|-----|-----|-----|------|------|-----|-----|
| 2400 | 1312 | 460 | 831 | 88 | 356 | 400 | 300 | 1440 | 1353 | 908 | 338 |

Heat Recovery Efficiency

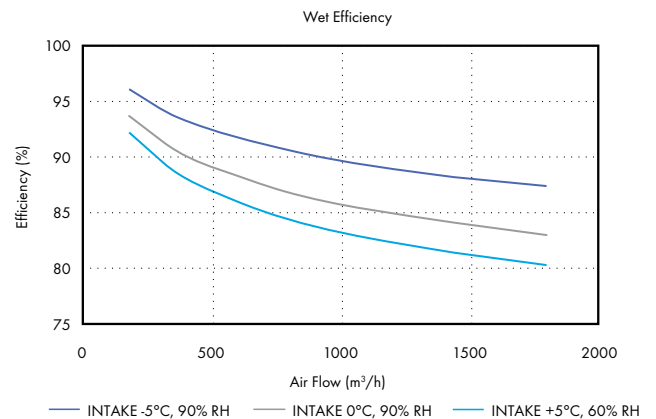
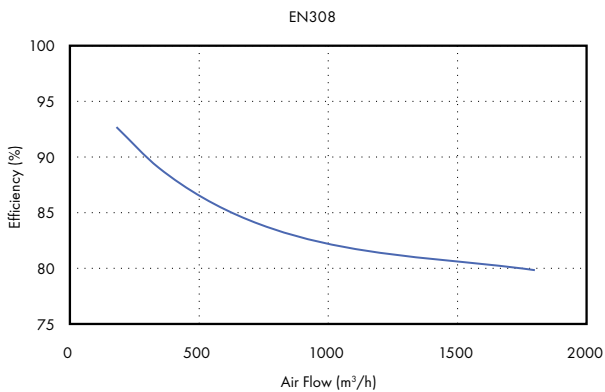

Performance Guide - Sentinel Apex HR10

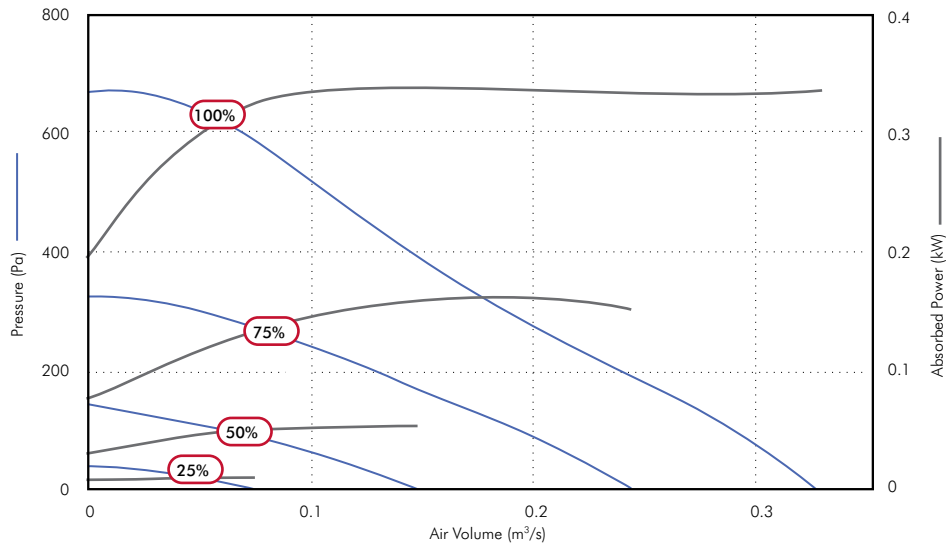

| Speed | Airflow, m³/s @ Pa | | | | | | | | | | | Fans F.L.C. | Supply Voltage | Frost Heater | Unit Rated Current | |
|-------|--------------------|-------|-------|-------|-------|-------|-------|-------|-------|-------|-------|----------------|-------------------|-----------------|-----------------------|--|
| | 0 | 25 | 50 | 100 | 150 | 200 | 250 | 300 | 400 | 500 | | | | | | |
| 100% | m³/s | 0.33 | 0.32 | 0.31 | 0.29 | 0.26 | 0.24 | 0.21 | 0.18 | 0.15 | 0.10 | 1.5A | 230/1/50 | 2.8kW | 14A | |
| | SFP | 1.03 | 1.05 | 1.08 | 1.17 | 1.28 | 1.40 | 1.61 | 1.87 | 2.32 | 3.24 | | | | | |
| | kW | 0.337 | 0.337 | 0.337 | 0.334 | 0.333 | 0.333 | 0.335 | 0.337 | 0.337 | 0.338 | | | | | |
| 75% | m³/s | 0.24 | 0.23 | 0.22 | 0.19 | 0.15 | 0.13 | 0.09 | | | | | | | | |
| | SFP | 0.62 | 0.67 | 0.74 | 0.84 | 1.03 | 1.22 | 1.55 | | | | | | | | |
| | kW | 0.151 | 0.155 | 0.160 | 0.160 | 0.160 | 0.153 | 0.138 | | | | | | | | |
| 50% | m³/s | 0.15 | 0.13 | 0.11 | 0.06 | | | | | | | | | | | |
| | SFP | 0.34 | 0.37 | 0.47 | 0.79 | | | | | | | | | | | |
| | kW | 0.050 | 0.050 | 0.051 | 0.046 | | | | | | | | | | | |
| 25% | m³/s | 0.07 | 0.03 | | | | | | | | | | | | | |
| | SFP | 0.08 | 0.21 | | | | | | | | | | | | | |
| | kW | 0.006 | 0.006 | | | | | | | | | | | | | |

Sound Data - Sentinel Apex HR10

| Speed | Test Mode | 63 | 125 | 250 | 500 | 1k | 2k | 4k | 8k | Sound Pressure level @ 3.0m dBA |
|-------|------------|----|-----|-----|-----|----|----|----|----|---------------------------------|
| 100% | Breakout | 57 | 53 | 55 | 47 | 42 | 40 | 36 | 26 | 30 |
| | Exhaust T4 | 55 | 57 | 63 | 54 | 56 | 52 | 42 | 33 | |
| | Extract T3 | 58 | 59 | 71 | 61 | 59 | 59 | 56 | 51 | |
| | Intake T1 | 58 | 58 | 68 | 58 | 60 | 59 | 56 | 51 | |
| | Supply T2 | 51 | 49 | 61 | 54 | 54 | 51 | 42 | 34 | |
| 75% | Breakout | 51 | 48 | 48 | 44 | 35 | 33 | 25 | 21 | 24 |
| | Exhaust T4 | 50 | 53 | 54 | 51 | 48 | 45 | 33 | 25 | |
| | Extract T3 | 53 | 56 | 52 | 56 | 54 | 51 | 48 | 41 | |
| | Intake T1 | 53 | 56 | 61 | 51 | 54 | 51 | 47 | 39 | |
| | Supply T2 | 46 | 46 | 53 | 48 | 46 | 44 | 33 | 25 | |
| 50% | Breakout | 45 | 44 | 35 | 33 | 24 | 23 | 18 | 21 | 14 |
| | Exhaust T4 | 44 | 49 | 39 | 38 | 38 | 35 | 22 | 23 | |
| | Extract T3 | 48 | 54 | 50 | 44 | 42 | 41 | 36 | 25 | |
| | Intake T1 | 47 | 52 | 51 | 42 | 42 | 40 | 34 | 25 | |
| | Supply T2 | 40 | 43 | 38 | 37 | 37 | 34 | 22 | 23 | |
| 25% | Breakout | 36 | 31 | 27 | 18 | 14 | 15 | 17 | 21 | 6 |
| | Exhaust T4 | 36 | 30 | 24 | 20 | 19 | 17 | 18 | 23 | |
| | Extract T3 | 40 | 37 | 34 | 26 | 23 | 19 | 19 | 22 | |
| | Intake T1 | 40 | 34 | 32 | 23 | 20 | 17 | 19 | 23 | |
| | Supply T2 | 31 | 27 | 24 | 20 | 17 | 15 | 18 | 23 | |

For full sound and performance data please use our Fan Selection Program www.vent-axia.com/fanselector/product/apex
 Sound data derived from independent testing at Sound Research Laboratories in accordance with EN ISO 3741:2010. Published dB(A) figures are free field sound pressure levels at 3m with spherical propagation at a reference level of 2×10^{-5} Pa. The inlet/outlet sound power level spectra figures are dB with a reference of 10^{-12} watts.

Accessories

Attenuator



Single skinned attenuators purpose designed for the Apex Heat Recovery range to minimise in duct noise. Attenuators are supplied in standard lengths of 900mm, 1200mm and 1500mm, constructed from Galvanised steel with profiled perforated sheet internal, mineral wool sound absorbing material and 30mm profiled flanges for duct and unit mounting. Data has been obtained by testing in accordance with BS EN ISO7235:2009.

| Stock Ref. | Dimensions (mm) | | | kg | Insertion Loss dB | | | | | | | | m ³ /hr @ Pa | | | | |
|--------------|-----------------|-------|--------|----|-------------------|-----|-----|-----|----|----|----|----|-------------------------|-----|------|------|------|
| | Length | Width | Height | | 63 | 125 | 250 | 500 | 1k | 2k | 4k | 8k | 300 | 600 | 1000 | 1500 | 2000 |
| ATT900-HR10 | 900 | 400 | 300 | 18 | 2 | 3 | 8 | 15 | 27 | 21 | 14 | 10 | 1 | 3 | 8 | 17 | 30 |
| ATT1200-HR10 | 1200 | 400 | 300 | 23 | 2 | 4 | 10 | 19 | 36 | 24 | 16 | 12 | 1 | 3 | 8 | 18 | 32 |
| ATT1500-HR10 | 1500 | 400 | 300 | 34 | 2 | 5 | 12 | 24 | 44 | 28 | 19 | 14 | 1 | 3 | 9 | 20 | 36 |

Duct mounted Heating / Cooling



Rectangular duct mounted heater battery with either electric heating complete with integral thyristor controls, or LPHW water heating, each designed to provide approximately 10°C temperature rise. Chilled water cooler also available with integral condensate tray. Note waterside controls are not included.

| Stock Ref. | Type | Dimensions (mm) | | | kg | Heater rating kW | Electrical supply | Water Temp | | | m ³ /hr @ Pa | | | | |
|------------|--|-----------------|-------|--------|----|------------------|-------------------|------------|--------|------------|-------------------------|-----|------|------|------|
| | | Length | Width | Height | | | | Flow | Return | Connection | 300 | 600 | 1000 | 1500 | 2000 |
| EHB-HR10 | HR 10 Duct mounted Rectangular electric heater with controls | 300 | 400 | 300 | 6 | 4.00 | 230/1/50 | N/A | N/A | N/A | 1 | 3 | 8 | 18 | 32 |
| HWB-HR10 | HR 10 Duct mounted Rectangular LPHW heating battery | 200 | 400 | 300 | 7 | 3.35 | N/A | 80°C | 60°C | 1/2" | 1 | 3 | 8 | 18 | 32 |
| CWB-HR10 | HR 10 Duct mounted Rectangular water cooling battery | 200 | 500 | 300 | 7 | 4.13 | N/A | 6°C | 12°C | 3/4" | 1 | 3 | 8 | 18 | 32 |

Roof Assembly

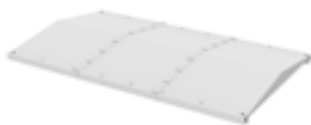

| Stock Ref | Length mm | Width mm | Height mm | Weight kg |
|-----------|-----------|----------|-----------|-----------|
| WRF-HR10 | 2400 | 1455 | 95 | 52 |

Intake / Exhaust Cowl



Weather inlet/discharge cowl for external mounting (one required for each airstream).

| Stock Ref | Length mm | Width mm | Height mm | Weight kg |
|-----------|-----------|----------|-----------|-----------|
| 497219 | 394 | 402 | 380 | 6 |

Transformation Piece



Rectangular to round transformation piece designed to fix directly to the unit or any of the specific HR10 duct accessories to enable connection to 315mm round ducting.

| Stock Ref | Length mm | Width mm | Height mm | Weight kg |
|-----------|-----------|----------|-----------|-----------|
| 497223 | 325 | 400 | 300 | 4 |

Flexible Connection



| Stock Ref | Length mm | Width mm | Height mm | Weight kg |
|-----------|-----------|----------|-----------|-----------|
| 497019 | 130 | 400 | 300 | 4 |

Sentinel Apex HR15

- Passivhaus Certified
- Very low sound levels independently tested and verified by SRL
- Low SFP utilising IE 5 equivalent motors
- High Heat Recovery Efficiency - up to 93% (EN308)
- Automatic summer bypass sized to eliminate performance loss
- ePM10 50% and ePM1 55% filters as standard (M5 / F7 equivalent)
- Filter access from bottom and side as standard
- Digital on board controller and remote room controller as standard
- App connectivity as standard
- Wired and Wireless communication sensors available
- Integral condensate tray and pump
- Electric frost protection heater as standard

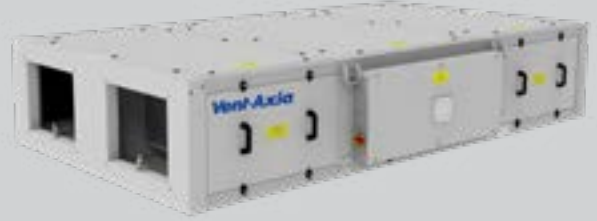

Passivhaus

Passivhaus MVHR is a critical part of a Passivhaus project and its success in driving down energy usage. The performance of the MVHR system is considered an integral element of the primary Passivhaus heating demand calculation. Vent-Axia's range of commercial MVHRs can support you with your next Passivhaus project with our most advanced MVHR systems available with wired or wireless sensors and controls. Our Passivhaus certified MVHRs provide up to 80% Thermal Efficiency, while providing an industry leading performance number of ≥ 11.5 .

Vent-Axia's commercial MVHR offers free cooling through an Intelligent Summer Bypass during the warmer months, contains F7/M5 filters as standard, along with option of the MVHR to provide Demand Controlled Ventilation, Constant Pressure or Constant Volume meaning you will have full control over your indoor environment. The MVHRs include internal frost protection pre-heaters, meaning you will achieve the best thermal comfort possible at all times.

Performance simply delivered with more as standard

Vent-Axia's Sentinel Apex range of commercial heat recovery units with up to 93% EN308 heat recovery efficiency, low sound levels and low specific fan powers the range provides high levels of performance efficiently. A new advanced control system that provides on board control, in room control and App based control full functionality commissioning and monitoring is simply provided. This control can be coupled with Vent-Axia's new range of sensors with wired or wireless communication providing close control of, and monitoring of your indoor air quality. Sensors include CO₂, humidity and temperature and provide both proportional and switch control.

The Sentinel Apex HR15 unit is manufactured with a double skinned pentapost construction incorporating aluzinc frames and panels. The panels are acoustically and thermally treated with 90kg/m³ high efficiency acoustic and thermally insulating foam (fire retardant to BS476 Part 7 Class 1 & Part 6 Class O). The construction of the unit, IPX4, allows for internal and external mounting as standard, however, the roof assembly should be included for full external locations.

The housing is designed to be as compact as possible for concealed false ceiling applications with top and bottom access panels for maintenance. Access panels are sized to enable single person maintenance.

The fans utilised in the Sentinel Apex HR15 are the latest EC/DC external rotor motors specifically chosen for their low power consumption and low noise characteristics. The assembly is dynamically balanced to DIN ISO 1940 Grade 6.3. Ball bearings are greased for life. Insulation is Class 'B' (from -25°C to +60°C). All models incorporate internal electronic overload protection and a soft start function.

The Sentinel Apex HR15 is complete as standard with ISO ePM10 50% (M5) extract filter and ISO ePM1 55% (F7) supply, complete with a filter change warning. Filters have been selected to fully comply with the requirements of ISO16890 whilst having low pressure loss characteristics.

An integral electric frost heater is included to provide frost protection of the cell and filters down to -10°C.

The unit is complete with an integral summer bypass facility which has been designed to provide full bypass without impact to the airflow or power consumption of the unit whilst in bypass mode.

Airflow and power consumption tested in accordance with BS EN 5801. Sound data derived from independent testing at Sound Research Laboratories in accordance with EN ISO 3741:2010. Published dB(A) figures are free field sound pressure levels at 3m with spherical propagation at a reference level of 2×10^{-5} Pa. The inlet/outlet sound power level spectra figures are dB with a reference of 10^{-12} watts.

An integral condensate tray is fitted along with an internal quiet running high quality pump allowing for removal of the condensate via a 10mm condensate pipe.

To facilitate normal access and maintenance to the unit there are both side and bottom access panels as standard. Should it be required, all panels are removable allowing access and removal of the heat recovery cell and all other components. A lockable isolator is fitted to the control panel preventing accidental operation whilst any maintenance is being carried out.

The electrical supply for the unit is 230V +/- 10% / 50/60Hz / 1ph. A 24V DC power is available from the unit for powering any of the matched sensors and switches.

The Sentinel Apex HR15 unit is fitted with an integrated control system as standard with a purpose designed user interface controller incorporating an alphanumeric 2 line display with 4 button keypad for fan status and a basic commissioning setup mounted within the control panel. A remote HMI is also included for that can be mounted within the room that is being ventilated. This allows for local monitoring of the unit along with the commissioning set-up.

A full range of sensors is available including humidity, temperature and CO₂ monitoring. These sensors are available for both wired and wireless communication with the wireless sensors being either local mains or battery powered.

App based control is also available via the Vent-Axia Connect App. This provides detailed commissioning and monitoring information and the ability to control the unit remotely.

Model Sentinel Apex HR15
Stock Ref HR15X

Dimensions (mm)

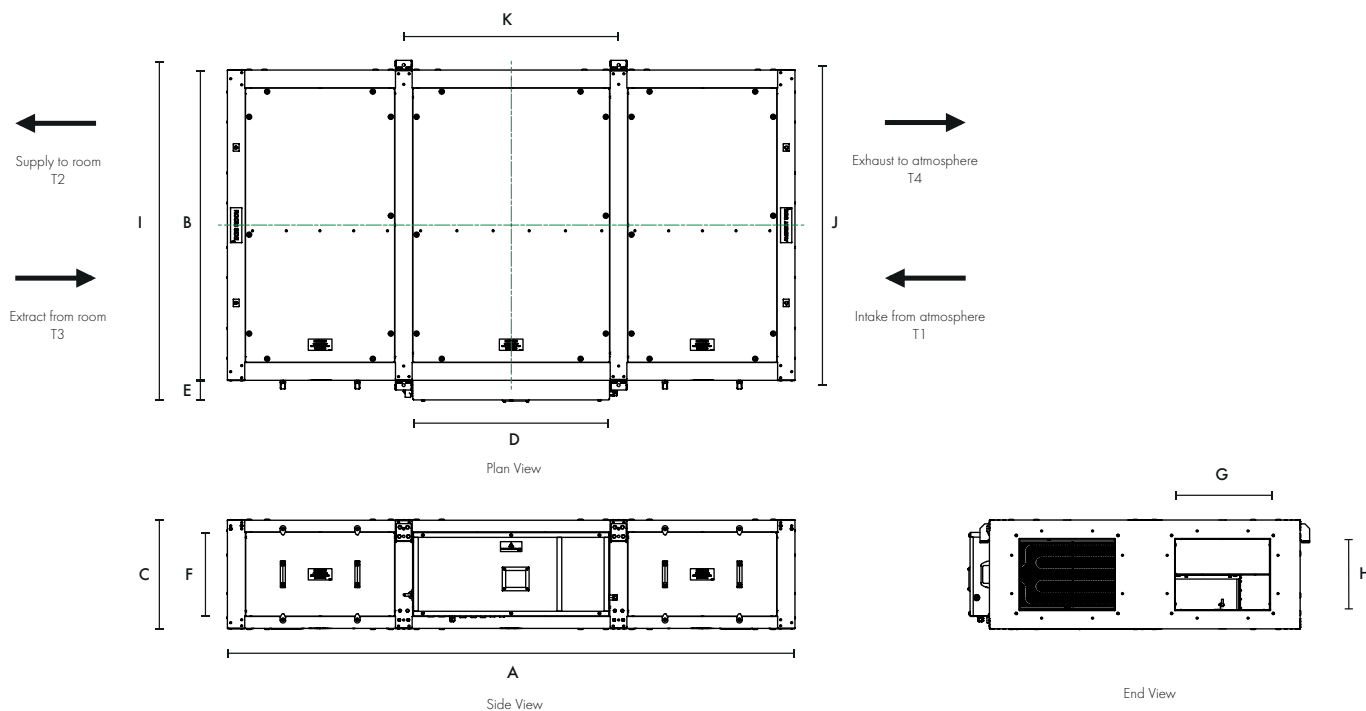

| A (LENGTH) | B (WIDTH) | C (HEIGHT) | D | E | F | G | H | I | J | K | kg |
|------------|-----------|------------|-----|----|-----|-----|-----|------|------|-----|-----|
| 2400 | 1312 | 460 | 831 | 88 | 356 | 400 | 300 | 1440 | 1353 | 908 | 348 |

Heat Recovery Efficiency

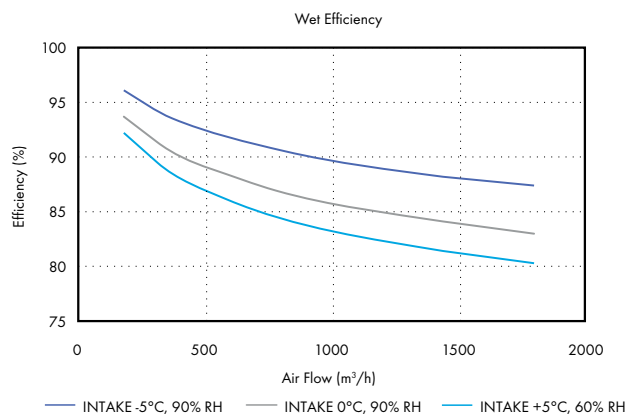
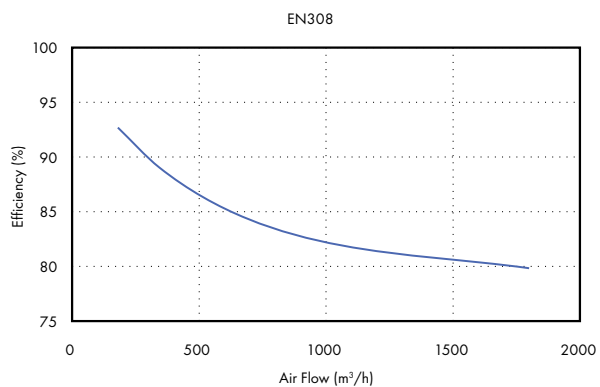

Performance Guide - Sentinel Apex HR15

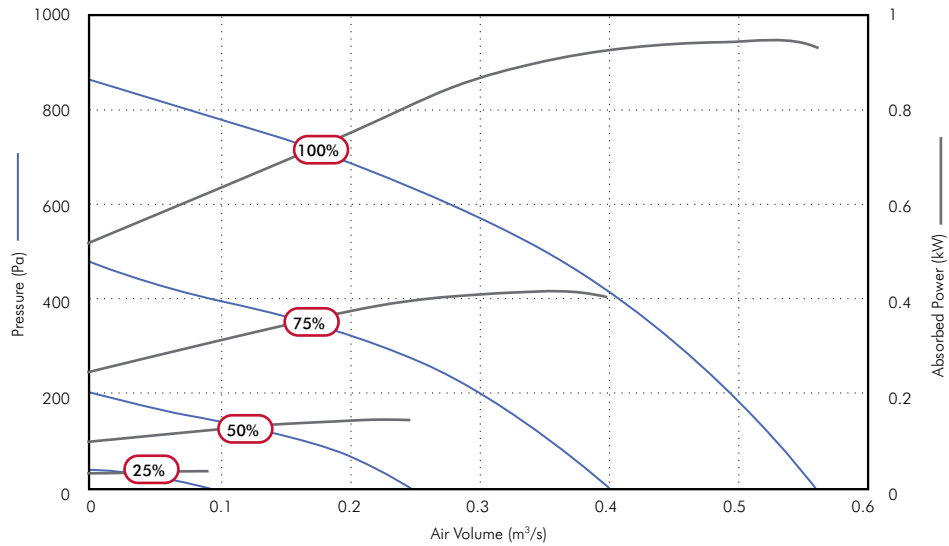

| Speed | Airflow, m³/s @ Pa | | | | | | | | | Fans F.L.C. | Supply Voltage | Frost Heater | Unit Rated Current |
|-------|--------------------|------|------|------|------|------|------|------|------|----------------|-------------------|-----------------|-----------------------|
| | 0 | 25 | 50 | 100 | 150 | 200 | 300 | 400 | | | | | |
| 100% | m³/s | 0.56 | 0.55 | 0.54 | 0.52 | 0.50 | 0.49 | 0.45 | 0.40 | 5.0A | 230/1/50 | 5.6kW | 29.0A |
| | SFP | 1.49 | 1.53 | 1.56 | 1.59 | 1.67 | 1.71 | 1.85 | 2.06 | | | | |
| | kW | 0.83 | 0.85 | 0.85 | 0.84 | 0.84 | 0.84 | 0.84 | 0.83 | | | | |
| 75% | m³/s | 0.40 | 0.39 | 0.38 | 0.35 | 0.33 | 0.30 | 0.22 | 0.09 | | | | |
| | SFP | 0.91 | 0.96 | 0.97 | 1.06 | 1.13 | 1.23 | 1.55 | 2.93 | | | | |
| | kW | 0.36 | 0.38 | 0.37 | 0.37 | 0.37 | 0.36 | 0.34 | 0.27 | | | | |
| 50% | m³/s | 0.25 | 0.23 | 0.21 | 0.16 | 0.09 | | | | | | | |
| | SFP | 0.51 | 0.56 | 0.60 | 0.76 | 1.20 | | | | | | | |
| | kW | 0.13 | 0.13 | 0.13 | 0.12 | 0.11 | | | | | | | |
| 25% | m³/s | 0.09 | 0.04 | | | | | | | | | | |
| | SFP | 0.32 | 0.63 | | | | | | | | | | |
| | kW | 0.03 | 0.03 | | | | | | | | | | |

Sound Data - Sentinel Apex HR15

| Speed | Test Mode | 63 | 125 | 250 | 500 | 1k | 2k | 4k | 8k | Sound Pressure level @ 3.0m dBA |
|-------|------------|----|-----|-----|-----|----|----|----|----|---------------------------------|
| 100% | Breakout | 65 | 59 | 67 | 59 | 51 | 48 | 41 | 40 | 38 |
| | Exhaust T4 | 63 | 60 | 46 | 64 | 62 | 57 | 46 | 36 | |
| | Extract T3 | 69 | 67 | 80 | 72 | 64 | 61 | 57 | 57 | |
| | Intake T1 | 70 | 67 | 79 | 69 | 65 | 62 | 57 | 53 | |
| | Supply T2 | 63 | 59 | 74 | 65 | 62 | 57 | 46 | 40 | |
| 75% | Breakout | 59 | 57 | 62 | 52 | 43 | 38 | 32 | 32 | 30 |
| | Exhaust T4 | 57 | 57 | 65 | 57 | 53 | 47 | 36 | 29 | |
| | Extract T3 | 64 | 64 | 72 | 65 | 56 | 53 | 48 | 50 | |
| | Intake T1 | 63 | 65 | 74 | 62 | 56 | 52 | 47 | 47 | |
| | Supply T2 | 56 | 56 | 67 | 57 | 53 | 58 | 36 | 33 | |
| 50% | Breakout | 53 | 57 | 46 | 40 | 32 | 27 | 23 | 24 | 22 |
| | Exhaust T4 | 50 | 53 | 48 | 43 | 41 | 35 | 24 | 24 | |
| | Extract T3 | 55 | 61 | 60 | 53 | 45 | 40 | 40 | 34 | |
| | Intake T1 | 56 | 62 | 60 | 51 | 45 | 40 | 38 | 28 | |
| | Supply T2 | 49 | 52 | 50 | 43 | 41 | 35 | 25 | 24 | |
| 25% | Breakout | 49 | 51 | 40 | 31 | 27 | 23 | 20 | 24 | 14 |
| | Exhaust T4 | 49 | 38 | 34 | 25 | 24 | 22 | 17 | 24 | |
| | Extract T3 | 52 | 42 | 42 | 31 | 26 | 26 | 18 | 24 | |
| | Intake T1 | 51 | 42 | 41 | 30 | 27 | 23 | 18 | 23 | |
| | Supply T2 | 47 | 36 | 33 | 25 | 24 | 21 | 16 | 23 | |

For full sound and performance data please use our Fan Selection Program www.vent-axia.com/fanselector/product/apex
 Sound data derived from independent testing at Sound Research Laboratories in accordance with EN ISO 3741:2010. Published dB(A) figures are free field sound pressure levels at 3m with spherical propagation at a reference level of 2×10^{-5} Pa. The inlet/outlet sound power level spectra figures are dB with a reference of 10^{-12} watts.

Accessories

Attenuator



Single skinned attenuators purpose designed for the Apex Heat Recovery range to minimise in duct noise. Attenuators are supplied in standard lengths of 900mm, 1200mm and 1500mm, constructed from Galvanised steel with profiled perforated sheet internal, mineral wool sound absorbing material and 30mm profiled flanges for duct and unit mounting. Data has been obtained by testing in accordance with BS EN ISO7235:2009.

| Stock Ref. | Dimensions (mm) | | | kg | Insertion Loss dB | | | | | | | | m ³ /hr @ Pa | | | | |
|--------------|-----------------|-------|--------|----|-------------------|-----|-----|-----|----|----|----|----|-------------------------|-----|------|------|------|
| | Length | Width | Height | | 63 | 125 | 250 | 500 | 1k | 2k | 4k | 8k | 300 | 600 | 1000 | 1500 | 2000 |
| ATT900-HR15 | 900 | 400 | 300 | 18 | 2 | 3 | 8 | 15 | 27 | 21 | 14 | 10 | 1 | 3 | 8 | 17 | 30 |
| ATT1200-HR15 | 1200 | 400 | 300 | 23 | 2 | 4 | 10 | 19 | 36 | 24 | 16 | 12 | 1 | 3 | 8 | 18 | 32 |
| ATT1500-HR15 | 1500 | 400 | 300 | 34 | 2 | 5 | 12 | 24 | 44 | 28 | 19 | 14 | 1 | 3 | 9 | 20 | 36 |

Duct mounted Heating / Cooling



Rectangular duct mounted heater battery with either electric heating complete with integral thyristor controls, or LPHW water heating, each designed to provide approximately 10°C temperature rise. Chilled water cooler also available with integral condensate tray. Note waterside controls are not included.

| Stock Ref. | Type | Dimensions (mm) | | | kg | Heater rating kW | Electrical supply | Water Temp | | | m ³ /hr @ Pa | | | | |
|------------|--|-----------------|-------|--------|----|------------------|-------------------|------------|--------|------------|-------------------------|-----|------|------|----|
| | | Length | Width | Height | | | | Flow | Return | Connection | 300 | 600 | 1000 | 1500 | 2k |
| EHB-HR15 | Heater with controls | 300 | 400 | 300 | 7 | 5.00 | 230/1/50 | N/A | N/A | N/A | 1 | 3 | 8 | 18 | 32 |
| HWB-HR15 | HR 15 Duct mounted Rectangular LPHW heating battery | 200 | 400 | 310 | 8 | 5.03 | N/A | 80°C | 60°C | 1/2" | 1 | 3 | 8 | 18 | 32 |
| CWB-HR15 | HR 15 Duct mounted Rectangular water cooling battery | 200 | 500 | 350 | 8 | 6.23 | N/A | 6°C | 12°C | 3/4" | 1 | 3 | 8 | 18 | 32 |

Roof Assembly

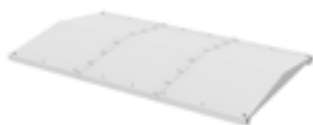

| Stock Ref | Length mm | Width mm | Height mm | Weight kg |
|-----------|-----------|----------|-----------|-----------|
| WRF-HR15 | 2400 | 1455 | 95 | 52 |

Intake / Exhaust Cowl



Weather inlet/discharge cowl for external mounting (one required for each airstream).

| Stock Ref | Length mm | Width mm | Height mm | Weight kg |
|-----------|-----------|----------|-----------|-----------|
| 496597 | 394 | 402 | 380 | 6 |

Transformation Piece



Rectangular to round transformation piece designed to fix directly to the unit or any of the specific HR15 duct accessories to enable connection to 315mm round ducting.

| Stock Ref | Length mm | Width mm | Height mm | Weight kg |
|-----------|-----------|----------|-----------|-----------|
| 495296 | 325 | 400 | 300 | 4 |

Flexible Connection



| Stock Ref | Length mm | Width mm | Height mm | Weight kg |
|-----------|-----------|----------|-----------|-----------|
| 497020 | 130 | 400 | 300 | 4 |

Sentinel Apex HR21

- Passivhaus Certified
- Very low sound levels independently tested and verified by SRL
- Low SFP utilising IE 5 equivalent motors
- High Heat Recovery Efficiency - up to 93% (EN308)
- Automatic summer bypass sized to eliminate performance loss
- ePM10 50% and ePM1 55% filters as standard (M5 / F7 equivalent)
- Filter access from bottom and side as standard
- Digital on board controller and remote room controller as standard
- App connectivity as standard
- Wired and Wireless communication sensors available
- Integral condensate tray and pump
- Electric frost protection heater as standard

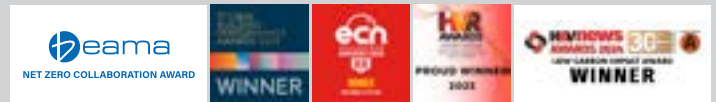
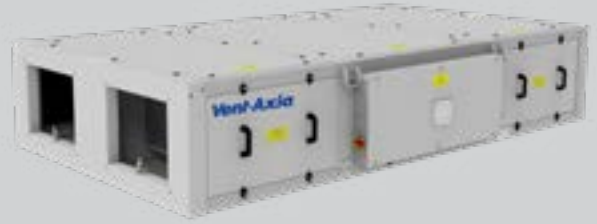

Passivhaus

Passivhaus MVHR is a critical part of a Passivhaus project and its success in driving down energy usage. The performance of the MVHR system is considered an integral element of the primary Passivhaus heating demand calculation. Vent-Axia's range of commercial MVHRs can support you with your next Passivhaus project with our most advanced MVHR systems available with wired or wireless sensors and controls. Our Passivhaus certified MVHRs provide up to 80% Thermal Efficiency, while providing an industry leading performance number of ≥ 11.5 .

Vent-Axia's commercial MVHR offers free cooling through an Intelligent Summer Bypass during the warmer months, contains F7/M5 filters as standard, along with option of the MVHR to provide Demand Controlled Ventilation, Constant Pressure or Constant Volume meaning you will have full control over your indoor environment. The MVHRs include internal frost protection pre-heaters, meaning you will achieve the best thermal comfort possible at all times.

Performance simply delivered with more as standard

Vent-Axia's Sentinel Apex range of commercial heat recovery units with up to 93% EN308 heat recovery efficiency, low sound levels and low specific fan powers the range provides high levels of performance efficiently. A new advanced control system that provides on board control, in room control and App based control full functionality commissioning and monitoring is simply provided. This control can be coupled with Vent-Axia's new range of sensors with wired or wireless communication providing close control of, and monitoring of your indoor air quality. Sensors include CO₂, humidity and temperature and provide both proportional and switch control.

The Sentinel Apex HR21 unit is manufactured with a double skinned pentapost construction incorporating aluzinc frames and panels. The panels are acoustically and thermally treated with 90kg/m³ high efficiency acoustic and thermally insulating foam (fire retardant to BS476 Part 7 Class 1 & Part 6 Class O). The construction of the unit, IPX4, allows for internal and external mounting as standard, however, the roof assembly should be included for full external locations.

The housing is designed to be as compact as possible for concealed false ceiling applications with top and bottom access panels for maintenance. Access panels are sized to enable single person maintenance.

The fans utilised in the Sentinel Apex HR21 are the latest EC/DC external rotor motors specifically chosen for their low power consumption and low noise characteristics. The assembly is dynamically balanced to DIN ISO 1940 Grade 6.3. Ball bearings are greased for life. Insulation is Class 'B' (from -25°C to +60°C). All models incorporate internal electronic overload protection and a soft start function.

The Sentinel Apex HR21 is complete as standard with ISO ePM10 50% (M5) extract filter and ISO ePM1 55% (F7) supply, complete with a filter change warning. Filters have been selected to fully comply with the requirements of ISO16890 whilst having low pressure loss characteristics.

An integral electric frost heater is included to provide frost protection of the cell and filters down to -10°C.

The unit is complete with an integral summer bypass facility which has been designed to provide full bypass without impact to the airflow or power consumption of the unit whilst in bypass mode.

Airflow and power consumption tested in accordance with BS EN 5801. Sound data derived from independent testing at Sound Research Laboratories in accordance with EN ISO 3741:2010. Published dB(A) figures are free field sound pressure levels at 3m with spherical propagation at a reference level of 2 x 10⁻⁵ Pa. The inlet/outlet sound power level spectra figures are dB with a reference of 10-12 watts.

An integral condensate tray is fitted along with an internal quiet running high quality pump allowing for removal of the condensate via a 10mm condensate pipe.

To facilitate normal access and maintenance to the unit there are both side and bottom access panels as standard. Should it be required, all panels are removable allowing access and removal of the heat recovery cell and all other components. A lockable isolator is fitted to the control panel preventing accidental operation whilst any maintenance is being carried out.

The electrical supply for the unit is 230V +/- 10% / 50/60Hz / 1ph. A 24V DC power is available from the unit for powering any of the matched sensors and switches. The Sentinel Apex HR21 unit is fitted with an integrated control system as standard with a purpose designed user interface controller incorporating an alphanumeric 2 line display.

mounted within the control panel. A remote HMI is also included for that can be mounted within the room that is being ventilated. This allows for local monitoring of the unit along with the commissioning set-up.

A full range of sensors is available including humidity, temperature and CO2 monitoring. These sensors are available for both wired and wireless communication with the wireless sensors being either local mains or battery powered.

App based control is also available via the Vent-Axia Connect App. This provides detailed commissioning and monitoring information and the ability to control the unit remotely.

Model **Sentinel Apex HR21**
 Stock Ref **HR21X**

Dimensions (mm)

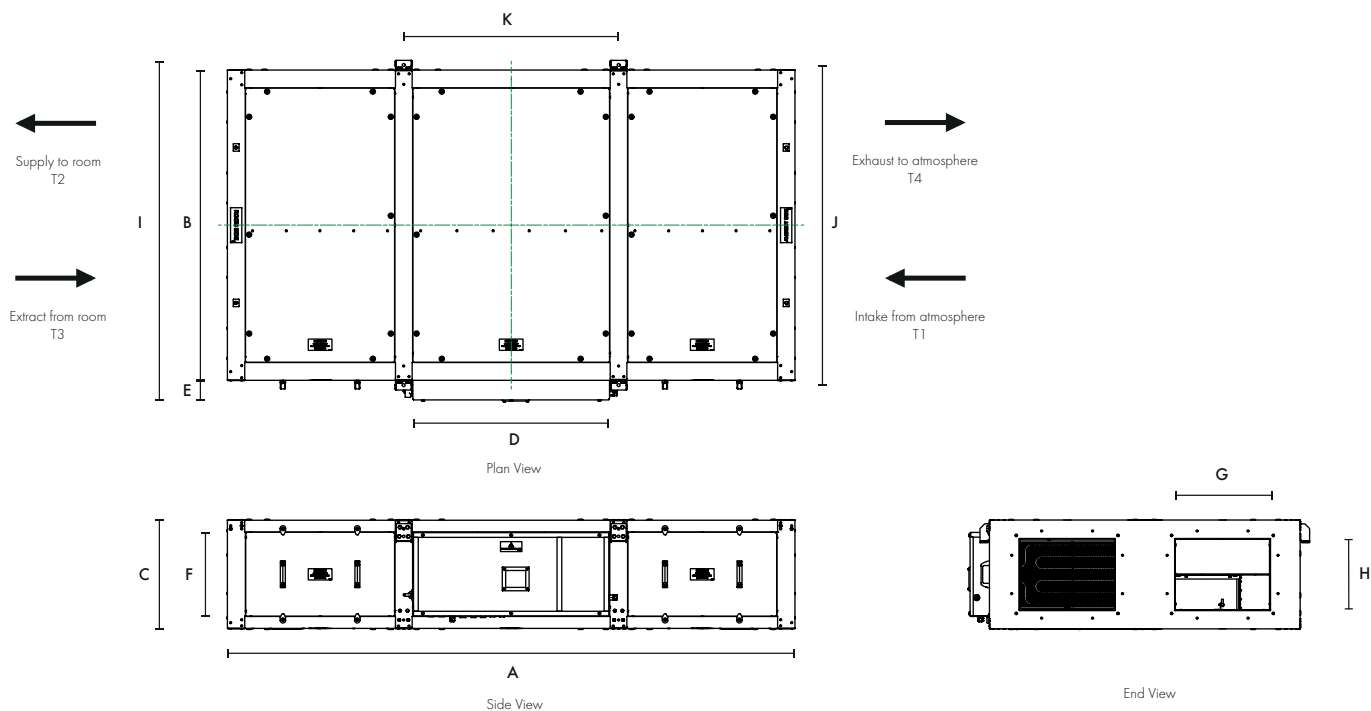

| A (LENGTH) | B (WIDTH) | C (HEIGHT) | D | E | F | G | H | I | J | K | kg |
|------------|-----------|------------|------|----|-----|-----|-----|------|------|------|-----|
| 2965 | 1319 | 620 | 1024 | 88 | 518 | 500 | 400 | 1446 | 1359 | 1097 | 470 |

Heat Recovery Efficiency

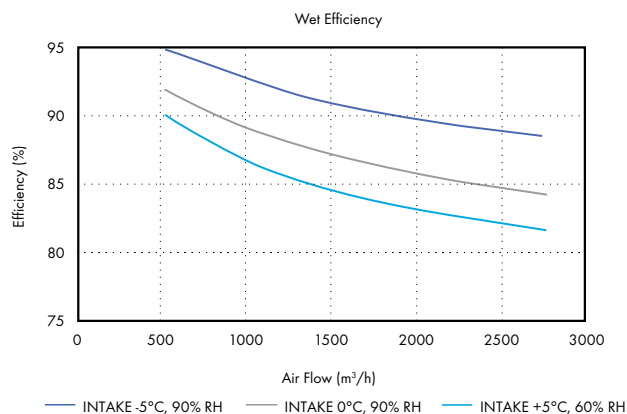
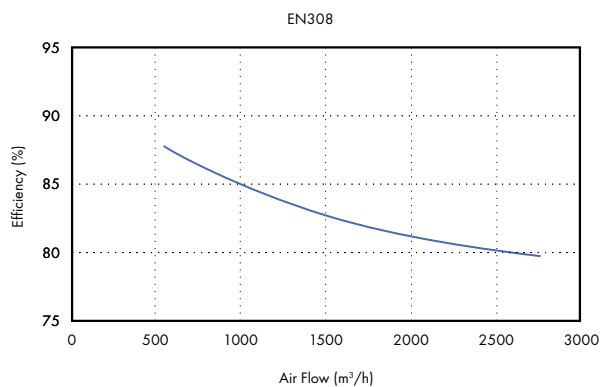

Performance Guide - Sentinel Apex HR21

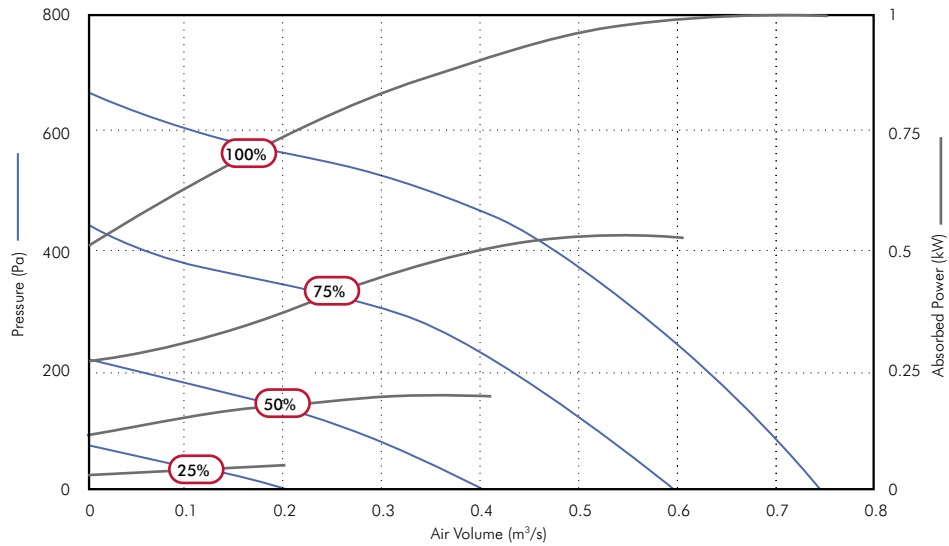

| Speed | Airflow, m³/s @ Pa | | | | | | | | | | | Fans F.L.C. | Supply Voltage | Frost Heater | Unit Rated Current | |
|-------|--------------------|-------|-------|-------|-------|-------|-------|-------|-------|-------|-------|----------------|-------------------|-----------------|-----------------------|-----|
| | 0 | 25 | 50 | 100 | 150 | 200 | 250 | 300 | 400 | 500 | 600 | | | | | |
| 100% | m³/s | 0.76 | 0.74 | 0.72 | 0.70 | 0.66 | 0.63 | 0.60 | 0.57 | 0.48 | 0.34 | 0.11 | 4.2A | 230/1/50 | 7.8kW | 39A |
| | SFP | 1.31 | 1.36 | 1.40 | 1.45 | 1.52 | 1.59 | 1.64 | 1.72 | 2.00 | 2.53 | 6.08 | | | | |
| kW | 1.004 | 1.004 | 1.005 | 1.007 | 1.009 | 1.002 | 0.988 | 0.973 | 0.970 | 0.856 | 0.655 | | | | | |
| 75% | m³/s | 0.60 | 0.59 | 0.56 | 0.52 | 0.49 | 0.43 | 0.38 | 0.31 | | | | | | | |
| | SFP | 0.89 | 0.92 | 0.97 | 1.04 | 1.09 | 1.22 | 1.32 | 1.49 | | | | | | | |
| 50% | kW | 0.538 | 0.540 | 0.542 | 0.541 | 0.534 | 0.522 | 0.498 | 0.459 | | | | | | | |
| | m³/s | 0.41 | 0.39 | 0.35 | 0.27 | 0.17 | 0.03 | | | | | | | | | |
| 25% | SFP | 0.53 | 0.55 | 0.62 | 0.75 | 1.08 | 5.22 | | | | | | | | | |
| | kW | 0.214 | 0.213 | 0.213 | 0.204 | 0.179 | 0.145 | | | | | | | | | |
| 25% | m³/s | 0.20 | 0.15 | 0.08 | | | | | | | | | | | | |
| | SFP | 0.30 | 0.39 | 0.59 | | | | | | | | | | | | |
| 25% | kW | 0.061 | 0.057 | 0.050 | | | | | | | | | | | | |

Sound Data - Sentinel Apex HR21

| Speed | Test Mode | Sound Pressure level @ 3.0m dBA | | | | | | | | |
|-------|------------|---------------------------------|-----|-----|-----|----|----|----|----|----|
| | | 63 | 125 | 250 | 500 | 1k | 2k | 4k | 8k | |
| 100% | Breakout | 60 | 57 | 57 | 47 | 44 | 38 | 34 | 32 | 31 |
| | Exhaust T4 | 60 | 58 | 60 | 57 | 57 | 51 | 44 | 42 | |
| | Extract T3 | 64 | 65 | 67 | 64 | 61 | 56 | 50 | 48 | |
| | Intake T1 | 63 | 65 | 68 | 64 | 61 | 56 | 51 | 49 | |
| | Supply T2 | 59 | 59 | 62 | 57 | 57 | 51 | 46 | 42 | |
| 75% | Breakout | 54 | 57 | 50 | 42 | 37 | 34 | 28 | 25 | 26 |
| | Exhaust T4 | 54 | 58 | 52 | 49 | 50 | 44 | 37 | 33 | |
| | Extract T3 | 58 | 65 | 63 | 56 | 53 | 49 | 43 | 41 | |
| | Intake T1 | 57 | 63 | 61 | 58 | 53 | 48 | 43 | 41 | |
| | Supply T2 | 52 | 54 | 52 | 48 | 50 | 44 | 39 | 34 | |
| 50% | Breakout | 51 | 52 | 45 | 35 | 31 | 27 | 21 | 22 | 20 |
| | Exhaust T4 | 65 | 55 | 47 | 40 | 42 | 36 | 30 | 27 | |
| | Extract T3 | 60 | 60 | 58 | 49 | 44 | 40 | 35 | 31 | |
| | Intake T1 | 57 | 62 | 56 | 49 | 45 | 39 | 34 | 31 | |
| | Supply T2 | 53 | 49 | 47 | 39 | 42 | 36 | 29 | 27 | |
| 25% | Breakout | 48 | 39 | 42 | 24 | 22 | 17 | 18 | 22 | 14 |
| | Exhaust T4 | 48 | 35 | 35 | 29 | 31 | 23 | 20 | 25 | |
| | Extract T3 | 57 | 44 | 44 | 37 | 34 | 29 | 21 | 26 | |
| | Intake T1 | 53 | 43 | 46 | 37 | 32 | 56 | 20 | 25 | |
| | Supply T2 | 44 | 34 | 34 | 28 | 30 | 22 | 19 | 25 | |

For full sound and performance data please use our Fan Selection Program www.vent-axia.com/fanselector/product/apex
 Sound data derived from independent testing at Sound Research Laboratories in accordance with EN ISO 3741:2010. Published dB(A) figures are free field sound pressure levels at 3m with spherical propagation at a reference level of 2×10^{-5} Pa. The inlet/outlet sound power level spectra figures are dB with a reference of 10^{-12} watts.

Accessories

Attenuator



Single skinned attenuators purpose designed for the Apex Heat Recovery range to minimise in duct noise. Attenuators are supplied in standard lengths of 900mm, 1200mm and 1500mm, constructed from Galvanised steel with profiled perforated sheet internal, mineral wool sound absorbing material and 30mm profiled flanges for duct and unit mounting. Data has been obtained by testing in accordance with BS EN ISO7235:2009.

| Stock Ref. | Dimensions (mm) | | | kg | Insertion Loss dB | | | | | | | | m ³ /hr @ Pa | | | | | |
|--------------|-----------------|-------|--------|----|-------------------|-----|-----|-----|----|----|----|----|-------------------------|-----|------|------|------|------|
| | Length | Width | Height | | 63 | 125 | 250 | 500 | 1k | 2k | 4k | 8k | 300 | 600 | 1000 | 1500 | 2000 | 3000 |
| ATT900-HR21 | 900 | 500 | 400 | 25 | 3 | 7 | 11 | 20 | 28 | 21 | 13 | 8 | 1 | 2 | 5 | 11 | 19 | 43 |
| ATT1200-HR21 | 1200 | 500 | 400 | 32 | 4 | 9 | 15 | 26 | 35 | 26 | 15 | 10 | 1 | 2 | 5 | 12 | 21 | 47 |
| ATT1500-HR21 | 1500 | 500 | 400 | 46 | 5 | 11 | 19 | 33 | 45 | 31 | 18 | 11 | 1 | 2 | 5 | 12 | 22 | 50 |

Duct mounted Heating / Cooling



Rectangular Duct mounted heater battery with either electric heating complete with integral thyristor controls, or LPHW water heating, each designed to provide approximately 10°C temperature rise. Chilled water cooler also available with integral condensate tray. Note waterside controls are not included.

| Stock Ref. | Type | Dimensions (mm) | | | kg | Heater rating kW | Electrical supply | Water Temp | | | m ³ /hr @ Pa | | | | | |
|------------|--|-----------------|-------|--------|----|------------------|-------------------|------------|--------|------------|-------------------------|-----|------|------|------|------|
| | | Length | Width | Height | | | | Flow | Return | Connection | 300 | 600 | 1000 | 1500 | 2000 | 3000 |
| EHB-HR21 | HR 21 Duct mounted Rectangular electric heater with controls | 300 | 500 | 400 | 10 | 7.50 | 415/3/50 | N/A | N/A | N/A | 1 | 2 | 5 | 12 | 21 | 47 |
| HWB-HR21 | HR 21 Duct mounted Rectangular LPHW heating battery | 200 | 500 | 400 | 10 | 7.03 | N/A | 80°C | 60°C | 1/2" | 1 | 2 | 5 | 12 | 21 | 47 |
| CWB-HR21 | HR 21 Duct mounted Rectangular water cooling battery | 200 | 500 | 400 | 10 | 8.65 | N/A | 6°C | 12°C | 3/4" | 1 | 2 | 5 | 12 | 21 | 47 |

Roof Assembly

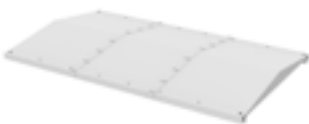

| Stock Ref | Length mm | Width mm | Height mm | Weight kg |
|-----------|-----------|----------|-----------|-----------|
| WRF-HR21 | 2965 | 1455 | 95 | 63 |

Intake / Exhaust Cowl



Weather inlet/discharge cowl for external mounting (one required for each airstream).

| Stock Ref | Length mm | Width mm | Height mm | Weight kg |
|-----------|-----------|----------|-----------|-----------|
| 497220 | 494 | 502 | 510 | 9 |

Transformation Piece



Rectangular to round transformation piece designed to fix directly to the unit or any of the specific HR21 duct accessories to enable connection to 400mm round ducting.

| Stock Ref | Length mm | Width mm | Height mm | Weight kg |
|-----------|-----------|----------|-----------|-----------|
| 497224 | 325 | 500 | 400 | 5 |

Flexible Connection



| Stock Ref | Length mm | Width mm | Height mm | Weight kg |
|-----------|-----------|----------|-----------|-----------|
| 497021 | 130 | 500 | 400 | 4 |

Sentinel Apex HR30

- Very low sound levels independently tested and verified by SRL
- Low SFP utilising IE 5 equivalent motors
- High Heat Recovery Efficiency – up to 93% (EN308)
- Automatic summer bypass sized to eliminate performance loss
- ePM10 50% and ePM1 55% filters as standard (M5 / F7 equivalent)
- Filter access from side as standard
- Digital on board controller and remote room controller as standard
- App connectivity as standard
- Wired and Wireless communication sensors available
- Integral condensate tray, gravity driven, pump accessory kit available
- Electric frost protection heater as standard



Performance simply delivered with more as standard Vent-Axia's Sentinel Apex range of commercial heat recovery units with up to 93% EN308 heat recovery efficiency, low sound levels and low specific fan powers the range provides high levels of performance efficiently.

The Sentinel Apex HR30 unit is manufactured with a double skinned pentapost construction incorporating aluzinc frames and panels. The panels are acoustically and thermally treated with 90kg/m³ high efficiency acoustic and thermally insulating foam (fire retardant to BS476 Part 7 Class 1 & Part 6 Class O). The construction of the unit, IPX4, allows for internal and external mounting as standard, no roof required for external installation.

Side access panels for maintenance are sized to enable single person maintenance. The fans utilised in the Sentinel Apex HR30 are the latest EC/DC external rotor motors specifically chosen for their low power consumption and low noise characteristics. The assembly is dynamically balanced to DIN ISO 1940 Grade 6.3. Ball bearings are greased for life. Insulation is Class 'B' (from -25°C to +60°C). All models incorporate internal electronic overload protection and a soft start function.

The Sentinel Apex HR30 is complete as standard with ISO ePM10 50% (M5) extract filter and ISO ePM1 55% (F7) supply, complete with a filter change warning. Filters have been selected to fully comply with the requirements of ISO 16890 whilst having low pressure loss characteristics.

An integral electric frost heater is included to provide frost protection of the cell and filters down to -10°C.

The unit is complete with an integral summer bypass facility which has been designed to provide full bypass without impact to the airflow or power consumption of the unit whilst in bypass mode.

Airflow and power consumption tested in accordance with BS EN 5801. Sound data derived from independent testing at Sound Research Laboratories in accordance with EN ISO 3741:2010. Published dB(A) figures are free field sound pressure levels at 3m with spherical propagation at a reference level of 2×10^{-5} Pa. The inlet/outlet sound power level spectra figures are dB with a reference of 10^{-12} watts.

An integral condensate tray is fitted inside the unit and as standard the drainage is gravity fed. An easy to connect, quiet running high quality condensate pump accessory kit can be purchased allowing for removal of the condensate via a 10mm condensate pipe when installed internally.

A lockable isolator is fitted to the control panel preventing accidental operation whilst any maintenance is being carried out. The electrical supply for the unit is 230V +/- 10% / 50/60Hz / 1ph. A 24V DC power is available from the unit for powering any of the matched sensors and switches.

The Sentinel Apex HR30 unit is fitted with an integrated control system as standard with a purpose designed user interface controller incorporating an alphanumeric 2 line display with 4 button keypad for fan status and a basic commissioning setup mounted within the control panel.

A remote HMI is also included for that can be mounted within the room that is being ventilated. This allows for local monitoring of the unit along with the commissioning set-up. App based control is also available via the Vent-Axia Connect App. This provides detailed commissioning and monitoring information and the ability to control the unit remotely.

A full range of sensors is available including humidity, temperature and CO₂ monitoring. These sensors are available for both wired and wireless communication.

Model
Sentinel Apex HR30

Stock Ref
HR30X

Dimensions (mm)

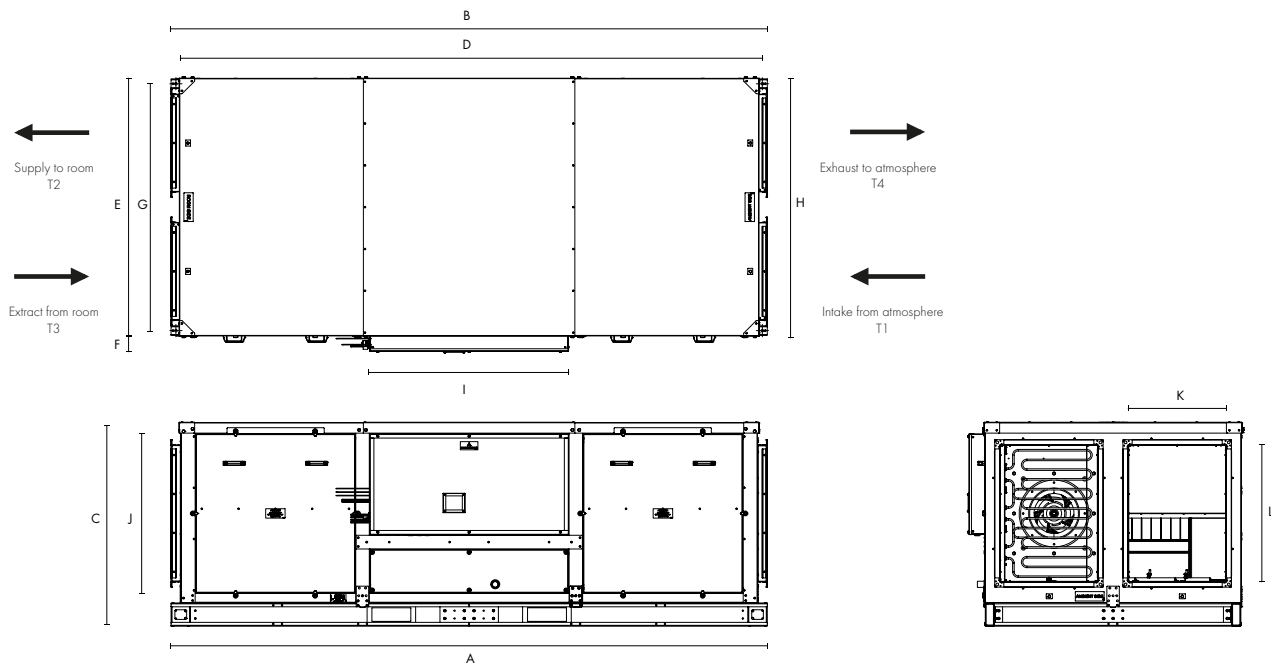

| A (LENGTH) | B (WIDTH) | C (HEIGHT) | D | E | F | G | H | I | J | K | kg |
|------------|-----------|------------|------|------|----|------|------|------|-----|-----|-----|
| 3065 | 1403 | 1051 | 3015 | 1324 | 79 | 1269 | 1341 | 1027 | 815 | 500 | 688 |

Heat Recovery Efficiency

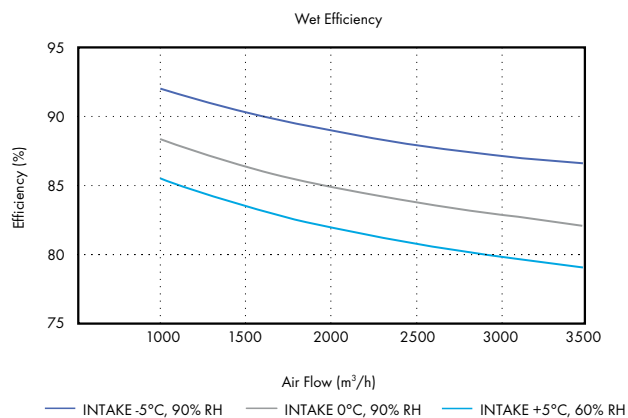
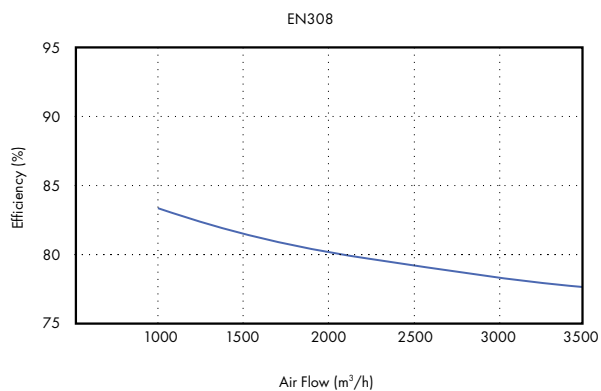

Performance Guide - Sentinel Apex HR30

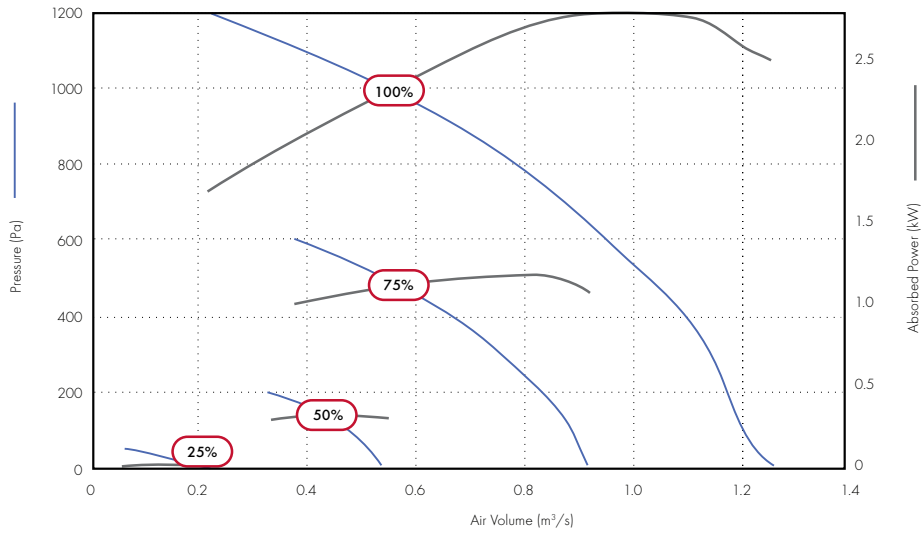

| Speed | Airflow, m ³ /s @ Pa | | | | | | | | | | Fans F.L.C. | Supply Voltage | Frost Heater | Unit Rated Current |
|-------|---------------------------------|------|------|------|------|------|------|------|------|------|-------------|----------------|--------------|--------------------|
| | 0 | 50 | 100 | 200 | 400 | 600 | 800 | 1000 | 1200 | | | | | |
| 100% | m ³ /s | 1.25 | 1.22 | 1.20 | 1.18 | 1.10 | 0.95 | 0.79 | 0.55 | 0.21 | 6.6A | 230/1/50 | 8.4kW | 36.5A |
| | SFP | 2.00 | 2.07 | 2.14 | 2.23 | 2.52 | 3.91 | 3.40 | 4.20 | 8.35 | | | | |
| | kW | 2.49 | 2.53 | 2.56 | 2.62 | 2.76 | 2.76 | 2.69 | 2.31 | 1.71 | | | | |
| 75% | m ³ /s | 0.91 | 0.90 | 0.88 | 0.83 | 0.67 | 0.37 | | | | | | | |
| | SFP | 1.20 | 1.24 | 1.31 | 1.44 | 1.76 | 2.78 | | | | | | | |
| | kW | 1.10 | 1.11 | 1.15 | 1.19 | 1.17 | 1.03 | | | | | | | |
| 50% | m ³ /s | 0.53 | 0.50 | 0.47 | 0.32 | | | | | | | | | |
| | SFP | 0.65 | 0.71 | 0.76 | 1.04 | | | | | | | | | |
| | kW | 0.34 | 0.36 | 0.35 | 0.33 | | | | | | | | | |
| 25% | m ³ /s | 0.20 | 0.05 | | | | | | | | | | | |
| | SFP | 0.31 | 1.04 | | | | | | | | | | | |
| | kW | 0.06 | 0.05 | | | | | | | | | | | |

Sound Data - Sentinel Apex HR30

| Speed | Test Mode | Sound Pressure level @ 3.0m dBA | | | | | | | | |
|-------|------------|---------------------------------|-----|-----|-----|----|----|----|----|----|
| | | 63 | 125 | 250 | 500 | 1k | 2k | 4k | 8k | |
| 100% | Breakout | 72 | 61 | 68 | 64 | 53 | 48 | 43 | 42 | 43 |
| | Exhaust T4 | 75 | 72 | 68 | 68 | 66 | 61 | 53 | 47 | |
| | Extract T3 | 77 | 76 | 82 | 83 | 70 | 65 | 6 | 58 | |
| | Intake T1 | 80 | 77 | 79 | 81 | 69 | 66 | 61 | 58 | |
| | Supply T2 | 74 | 69 | 72 | 66 | 66 | 63 | 60 | 58 | |
| 75% | Breakout | 67 | 57 | 61 | 56 | 45 | 41 | 35 | 32 | 35 |
| | Exhaust T4 | 68 | 67 | 65 | 56 | 58 | 54 | 45 | 38 | |
| | Extract T3 | 72 | 75 | 79 | 72 | 61 | 57 | 52 | 50 | |
| | Intake T1 | 74 | 75 | 75 | 72 | 60 | 58 | 53 | 50 | |
| | Supply T2 | 67 | 66 | 66 | 57 | 58 | 59 | 52 | 46 | |
| 50% | Breakout | 58 | 58 | 49 | 42 | 39 | 42 | 22 | 21 | 28 |
| | Exhaust T4 | 59 | 67 | 53 | 45 | 46 | 42 | 33 | 27 | |
| | Extract T3 | 65 | 72 | 62 | 57 | 49 | 45 | 42 | 34 | |
| | Intake T1 | 66 | 74 | 63 | 56 | 49 | 46 | 43 | 35 | |
| | Supply T2 | 59 | 65 | 53 | 45 | 50 | 50 | 39 | 27 | |
| 25% | Breakout | 61 | 38 | 41 | 28 | 28 | 26 | 17 | 20 | 16 |
| | Exhaust T4 | 51 | 47 | 36 | 30 | 27 | 24 | 18 | 22 | |
| | Extract T3 | 53 | 52 | 40 | 37 | 31 | 29 | 19 | 22 | |
| | Intake T1 | 55 | 49 | 40 | 38 | 31 | 28 | 20 | 22 | |
| | Supply T2 | 53 | 44 | 36 | 35 | 30 | 25 | 18 | 22 | |

For full sound and performance data please use our Fan Selection Program www.vent-axia.com/fanselector/product/apex
 Sound data derived from independent testing at Sound Research Laboratories in accordance with EN ISO 3741:2010. Published dB(A) figures are free field sound pressure levels at 3m with spherical propagation at a reference level of 2×10^{-5} Pa. The inlet/outlet sound power level spectra figures are dB with a reference of 10^{-12} watts.

Accessories

Attenuator



Single skinned attenuators purpose designed for the Apex Heat Recovery range to minimise in duct noise. Attenuators are supplied in standard lengths of 900mm, 1200mm and 1500mm, constructed from Galvanised steel with profiled perforated sheet internal, mineral wool sound absorbing material and 30mm profiled flanges for duct and unit mounting. Data has been obtained by testing in accordance with BS EN ISO7235:2009.

| Stock Ref. | Dimensions (mm) | | | kg | Insertion Loss dB | | | | | | | | m ³ /hr @ Pa | | | | |
|--------------|-----------------|-------|--------|----|-------------------|-----|-----|-----|----|----|----|----|-------------------------|------|------|------|------|
| | Length | Width | Height | | 63 | 125 | 250 | 500 | 1k | 2k | 4k | 8k | 1000 | 1500 | 2000 | 3000 | 4000 |
| ATT900-HR30 | 900 | 500 | 700 | 33 | 3 | 7 | 11 | 21 | 22 | 24 | 9 | 5 | 1 | 3 | 4 | 9 | 16 |
| ATT1200-HR30 | 1200 | 500 | 700 | 41 | 3 | 9 | 14 | 27 | 28 | 28 | 11 | 6 | 2 | 3 | 5 | 10 | 17 |
| ATT1500-HR30 | 1500 | 500 | 700 | 60 | 4 | 11 | 18 | 34 | 34 | 22 | 12 | 7 | 3 | 3 | 5 | 11 | 19 |

Duct mounted Heating / Cooling



Rectangular Duct mounted heater battery with either electric heating complete with integral thyristor controls, or LPHW water heating, each designed to provide approximately 10°C temperature rise. Chilled water cooler also available with integral condensate tray. Note waterside controls are not included.

| Stock Ref. | Type | Dimensions (mm) | | | kg | Heater rating kW | Electrical supply | Water Temp | | | m ³ /hr @ Pa | | | |
|------------|--|-----------------|-------|--------|------|------------------|-------------------|------------|--------|------------|-------------------------|------|------|------|
| | | Length | Width | Height | | | | Flow | Return | Connection | 1000 | 1500 | 2000 | 3000 |
| EHB-HR30 | HR 30 Duct mounted Rectangular electric heater with controls | 300 | 500 | 700 | 14 | 10 | 415/3/50 | N/A | N/A | N/A | - | - | - | 16 |
| HWB-HR30 | HR 30 Duct mounted Rectangular LPHW heating battery | 200 | 500 | 700 | 7.5 | 10.41 | N/A | 80°C | 60°C | 1/2" | 1 | 3 | 4 | 9 |
| CWB-HR30* | HR 30 Duct mounted Rectangular water cooling battery | 200 | 500 | 700 | 14.7 | 12.09 | N/A | 6°C | 12°C | 1" | 8 | 16 | 25 | 47 |

*This wet cooling coil is suitable for the HR30X left handed model, a CWB-HR30RX will be required for a HR30RX right-handed model

Intake / Exhaust Louvre



Class A weather louvre allowing 50% air whilst rejecting 99% of the rain, utilised for intake/discharge duct connections of the HR30 when installed externally. Weather inlet/discharge louvre for external mounting (one required for each airstream).

| Stock Ref | Length mm | Width mm | Height mm | Weight kg |
|-----------|-----------|----------|-----------|-----------|
| 414320 | 200 | 500 | 700 | 19 |

Condensate Pump

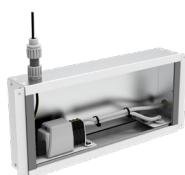

Transformation Piece



Rectangular to round transformation piece designed to fix directly to the unit or any of the specific HR30 duct accessories to enable connection to 400mm round ducting.

| Stock Ref | Length mm | Width mm | Height mm | Weight kg |
|-----------|-----------|----------|-----------|-----------|
| 414277 | 430 | 500 | 700 | 6 |

Flexible Connection



| Stock Ref | Length mm | Width mm | Height mm | Weight kg |
|-----------|-----------|----------|-----------|-----------|
| 414278 | 100 | 500 | 700 | 6 |

Sentinel Apex HR40

- Very low sound levels independently tested and verified by SRL
- Low SFP utilising IE 5 equivalent motors
- High Heat Recovery Efficiency – up to 93% (EN308)
- Automatic summer bypass sized to eliminate performance loss
- ePM10 50% and ePM1 50% filters as standard (M5 / F7 equivalent)
- Filter access from side as standard
- Digital on board controller and remote room controller as standard
- App connectivity as standard
- Wired and Wireless communication sensors available
- Integral condensate tray, gravity driven
- Electric frost protection heater bolt-on available



Performance simply delivered with more as standard Vent-Axia's Sentinel Apex range of commercial heat recovery units with up to 93% EN308 heat recovery efficiency, low sound levels and low specific fan powers the range provides high levels of performance efficiently.

The Sentinel Apex HR40 unit is manufactured with a double skinned construction incorporating Aluzinc frames and panels. The panels are acoustically and thermally treated with 90kg/m³ high efficiency acoustic and thermally insulating foam (fire retardant to BS476 Part 7 Class 1 & Part 6 Class O). The construction of the unit, IPX2 and IPX4 (with weather roof) allows for internal and external mounting as standard, however, the roof assembly should be included for full external locations, to be specified at time of order.

The fans utilised in the Sentinel Apex HR40 are the latest EC/DC external rotor motors specifically chosen for their low power consumption and low noise characteristics. The assembly is dynamically balanced to DIN ISO 1940 Grade 6.3. Ball bearings are greased for life. Insulation is Class 'B' (from -25°C to +60°C). All models incorporate internal electronic overload protection and a soft start function.

The Sentinel Apex HR40 is complete as standard with ISO ePM10 50% (M5) extract filter and ISO ePM1 50% (F7) supply, complete with a filter change warning. Filters have been selected to fully comply with the requirements of ISO 16890 whilst having low pressure loss characteristics.

A bolt on addition electric frost heater can be provided to allow frost protection of the cell and filters down to -10°C.

The unit is complete with an integral summer bypass facility which has been designed to provide full bypass without impact to the airflow or power consumption of the unit whilst in bypass mode.

Airflow and power consumption tested in accordance with BS EN 5801. Sound data derived from independent testing at Sound Research Laboratories in accordance with EN ISO 3741:2010. Published dB(A) figures are free field sound pressure levels at 3m with spherical propagation at a reference level of 2×10^{-5} Pa. The inlet/outlet sound power level spectra figures are dB with a reference of 10^{-12} watts.

An integral condensate tray is fitted inside the unit and as standard the drainage is gravity fed and complete with a Condensate Ball Siphone Trap Heater.

A lockable isolator is fitted to the control panel preventing accidental operation whilst any maintenance is being carried out. The electrical supply for the unit is 415V +/- 10% / 50/ 60Hz / 3ph. A 24V DC power is available from the unit for powering any of the matched sensors and switches.

The Sentinel Apex HR40 unit is fitted with an integrated control system as standard with a purpose designed user interface controller incorporating an alphanumeric 2 line display with 4 button keypad for fan status and a basic commissioning setup mounted within the control panel.

A remote HMI is also included for that can be mounted within the room that is being ventilated. This allows for local monitoring of the unit along with the commissioning set-up. App based control is also available via the Vent-Axia Connect App. This provides detailed commissioning and monitoring information and the ability to control the unit remotely.

A full range of sensors is available including humidity, temperature and CO₂ monitoring. These sensors are available for both wired and wireless communication.

Model
Sentinel Apex HR40

Stock Ref
HR40X

Dimensions (mm)

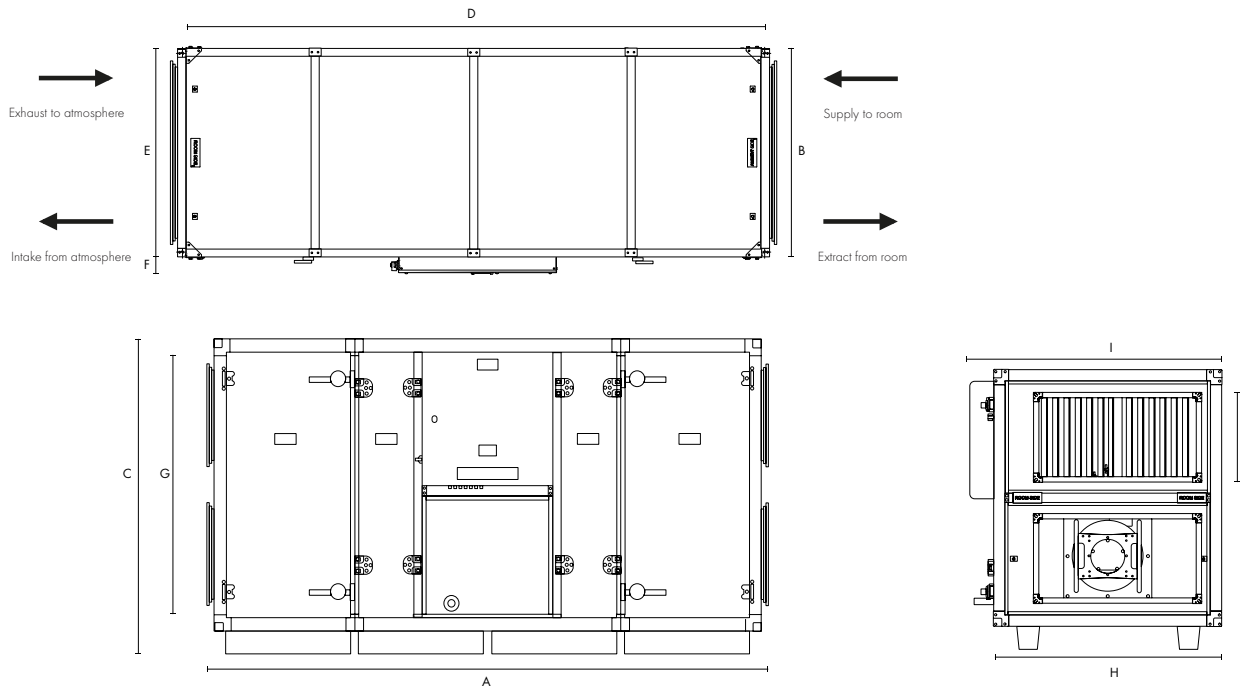

| A (LENGTH) | B (WIDTH) | C (HEIGHT) | D | E | F | G | H | I | J | kg |
|------------|-----------|------------|------|------|-----|------|------|------|-----|-----|
| 2600 | 1161 | 1407 | 2541 | 1307 | 100 | 1196 | 1161 | 1304 | 398 | 640 |

Heat Recovery Efficiency

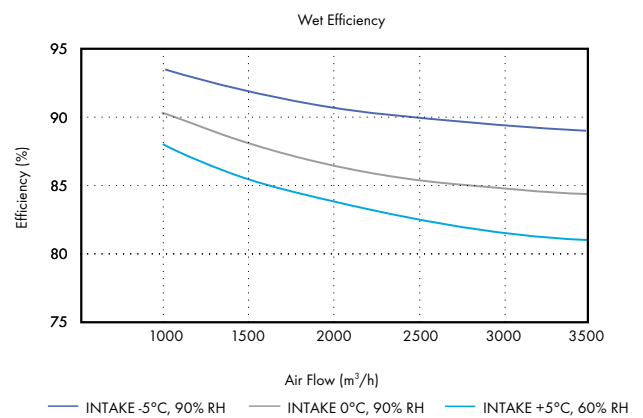
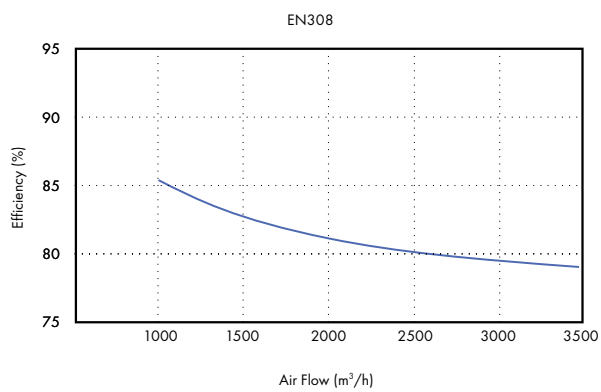

Performance Guide - Sentinel Apex HR40

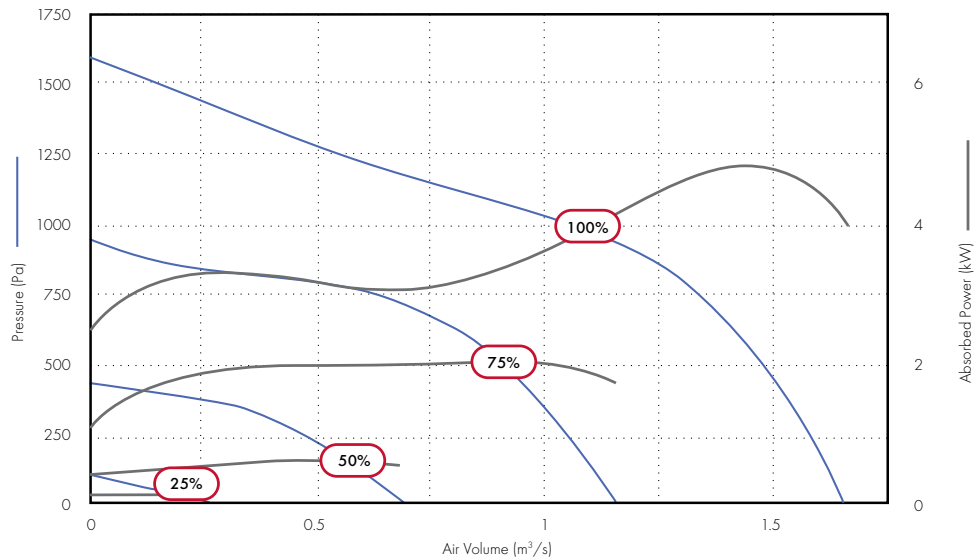

| Speed | Airflow, m ³ /s @ Pa | | | | | | | | | | | | | | Fans F.L.C. | Supply Voltage | Frost Heater | Unit Rated Current |
|-------|---------------------------------|------|------|------|------|------|------|------|------|------|------|------|-------|------|----------------|-------------------|-----------------|-----------------------|
| | 0 | 25 | 50 | 100 | 200 | 300 | 400 | 500 | 600 | 700 | 800 | 900 | 1000 | | | | | |
| 100% | m ³ /s | 1.66 | 1.65 | 1.64 | 1.62 | 1.60 | 1.56 | 1.52 | 1.47 | 1.44 | 1.37 | 1.31 | 1.17 | 1.03 | 3.7A | 400/3/50 | 9kW | 17.8A |
| | SFP | 2.49 | 2.53 | 2.56 | 2.63 | 2.76 | 2.91 | 3.06 | 3.22 | 3.35 | 3.54 | 3.74 | 3.69 | 3.62 | | | | |
| | kW | 4.14 | 4.18 | 4.21 | 4.27 | 4.41 | 4.54 | 4.65 | 4.74 | 4.82 | 4.85 | 4.89 | 4.30 | 3.72 | | | | |
| 75% | m ³ /s | 1.15 | 1.14 | 1.13 | 1.12 | 1.06 | 1.01 | 0.96 | 0.92 | 0.86 | 0.69 | 0.42 | 0.14 | | | | | |
| | SFP | 1.53 | 1.55 | 1.58 | 1.64 | 1.80 | 1.95 | 2.09 | 2.18 | 2.32 | 2.83 | 4.56 | 10.69 | | | | | |
| | kW | 1.76 | 1.78 | 1.80 | 1.85 | 1.91 | 1.97 | 2.00 | 2.01 | 1.99 | 1.94 | 1.90 | 1.48 | | | | | |
| 50% | m ³ /s | 0.68 | 0.66 | 0.64 | 0.59 | 0.51 | 0.38 | 0.11 | | | | | | | | | | |
| | SFP | 0.80 | 0.84 | 0.88 | 0.99 | 1.17 | 1.44 | 3.84 | | | | | | | | | | |
| | kW | 0.55 | 0.55 | 0.57 | 0.59 | 0.59 | 0.55 | 0.43 | | | | | | | | | | |
| 25% | m ³ /s | 0.25 | 0.21 | 0.13 | | | | | | | | | | | | | | |
| | SFP | 0.40 | 0.49 | 0.80 | | | | | | | | | | | | | | |
| | kW | 0.10 | 0.10 | 0.10 | | | | | | | | | | | | | | |

Sound Data - Sentinel Apex HR40

| Speed | Test Mode | Sound Pressure level @ 3.0m dBA | | | | | | | | |
|-------|------------|---------------------------------|-----|-----|-----|----|----|----|----|----|
| | | 63 | 125 | 250 | 500 | 1k | 2k | 4k | 8k | |
| 100% | Breakout | 76 | 70 | 75 | 65 | 63 | 59 | 54 | 45 | 49 |
| | Exhaust T4 | 76 | 79 | 81 | 80 | 84 | 79 | 74 | 70 | |
| | Extract T3 | 68 | 66 | 73 | 67 | 60 | 54 | 44 | 36 | |
| | Intake T1 | 67 | 65 | 72 | 56 | 56 | 54 | 43 | 35 | |
| | Supply T2 | 75 | 75 | 79 | 78 | 82 | 79 | 74 | 70 | |
| 75% | Breakout | 72 | 69 | 73 | 58 | 54 | 50 | 45 | 38 | 44 |
| | Exhaust T4 | 69 | 75 | 82 | 71 | 75 | 70 | 65 | 63 | |
| | Extract T3 | 63 | 61 | 68 | 58 | 54 | 46 | 36 | 28 | |
| | Intake T1 | 61 | 60 | 62 | 49 | 59 | 43 | 34 | 27 | |
| | Supply T2 | 69 | 71 | 76 | 69 | 73 | 70 | 65 | 62 | |
| 50% | Breakout | 62 | 64 | 55 | 46 | 43 | 38 | 33 | 26 | 31 |
| | Exhaust T4 | 61 | 80 | 61 | 59 | 63 | 58 | 52 | 51 | |
| | Extract T3 | 55 | 63 | 50 | 46 | 43 | 33 | 23 | 23 | |
| | Intake T1 | 53 | 63 | 47 | 37 | 48 | 30 | 22 | 25 | |
| | Supply T2 | 60 | 69 | 56 | 58 | 62 | 58 | 53 | 50 | |
| 25% | Breakout | 62 | 42 | 40 | 33 | 31 | 20 | 17 | 20 | 19 |
| | Exhaust T4 | 60 | 48 | 39 | 43 | 45 | 36 | 25 | 24 | |
| | Extract T3 | 50 | 36 | 36 | 27 | 25 | 17 | 18 | 24 | |
| | Intake T1 | 47 | 34 | 27 | 22 | 19 | 15 | 18 | 24 | |
| | Supply T2 | 58 | 46 | 37 | 46 | 45 | 35 | 30 | 25 | |

For full sound and performance data please use our Fan Selection Program www.vent-axia.com/fanselector/product/apex
 Sound data derived from independent testing at Sound Research Laboratories in accordance with EN ISO 3741:2010. Published dB(A) figures are free field sound pressure levels at 3m with spherical propagation at a reference level of 2×10^{-5} Pa. The inlet/outlet sound power level spectra figures are dB with a reference of 10^{-12} watts.

Accessories

Attenuator

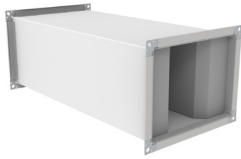

Single skinned attenuators purpose designed for the MVHRe Heat Recovery range to minimise in duct noise. Attenuators are supplied in standard lengths of 900mm, 1200mm and 1500mm, constructed from Galvanised steel with profiled perforated sheet internal, mineral wool sound absorbing material and 30mm profiled flanges for duct and unit mounting. Data has been obtained by testing in accordance with BS EN ISO7235:2009.

| Stock Ref. | Dimensions (mm) | | | kg | Insertion Loss dB | | | | | | | | m ³ /hr @ Pa | | | | | |
|--------------|-----------------|-------|--------|----|-------------------|-----|-----|-----|----|----|----|----|-------------------------|-----|------|------|------|------|
| | Length | Width | Height | | 63 | 125 | 250 | 500 | 1k | 2k | 4k | 8k | 300 | 600 | 1000 | 1500 | 2000 | 3000 |
| ATT900-HR40 | 900 | 800 | 400 | 33 | 2 | 4 | 7 | 14 | 22 | 15 | 9 | 6 | 1 | 1 | 1 | 3 | 4 | 9 |
| ATT1200-HR40 | 1200 | 800 | 400 | 41 | 3 | 5 | 9 | 17 | 28 | 18 | 11 | 6 | 1 | 1 | 2 | 3 | 5 | 10 |
| ATT1500-HR40 | 1500 | 800 | 400 | 60 | 4 | 6 | 10 | 21 | 34 | 22 | 12 | 7 | 1 | 1 | 2 | 3 | 5 | 11 |

Duct mounted Heating / Cooling



Rectangular duct mounted heater battery with either electric heating complete with integral thyristor controls, or LPHW water heating, each designed to provide approximately 10°C temperature rise. Chilled water cooler also available with integral condensate tray. Note waterside controls are not included.

| Stock Ref. | Type | Dimensions (mm) | | | kg | Heater rating kW | Electrical supply | Water Temp | | Connection | m ³ /hr @ Pa | | | | | | | |
|------------|---|-----------------|-----|-----|------|------------------|-------------------|------------|--------|------------|-------------------------|-----|------|------|------|------|---|---|
| | | L | W | H | | | | Flow | Return | | 300 | 600 | 1000 | 1500 | 2000 | 3000 | | |
| EHB-HR40 | HR40 Duct mounted Rectangular electric heater with controls | 300 | 500 | 700 | 14 | 10.00 | 415/3/50 | N/A | N/A | N/A | - | - | - | - | - | - | - | - |
| HWB-HR40 | HR40 Duct mounted Rectangular LPHW heating battery | 100 | 590 | 760 | 7.5 | 10.41 | N/A | 80°C | 60°C | 1/2" | 0 | 1 | 3 | 6 | 9 | 17 | | |
| CWB-HR40 | HR40 Duct mounted Rectangular water cooling battery | 100 | 590 | 760 | 14.7 | 12.09 | N/A | 6°C | 12°C | 1" | 1 | 4 | 8 | 15 | 24 | 46 | | |

Intake / Exhaust Cowl



Weather inlet/discharge cowl for external mounting (one required for each airstream).

| Stock Ref | Length mm | Width mm | Height mm | Weight kg |
|-----------|-----------|----------|-----------|-----------|
| 497221 | 498 | 804 | 501 | 12 |

Transformation Piece



Rectangular to round transformation piece designed to fix directly to the unit or any of the specific HR40 duct accessories to enable connection to 250mm round ducting.

| Stock Ref | Length mm | Width mm | Height mm | Weight kg |
|-----------|-----------|----------|-----------|-----------|
| 414277 | 430 | 802 | 500 | 8 |

Flexible Connection



| Stock Ref | Length mm | Width mm | Height mm | Weight kg |
|-----------|-----------|----------|-----------|-----------|
| 497022 | 100 | 800 | 400 | 6 |

CONTROLS & SENSORS



Basic On-Board Control

- Unit integrated 2 line LCD Display
- Accessible on the unit
- Basic monitoring and commissioning functions
- Wired sensor connection

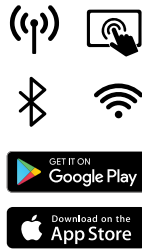

Digital Remote Control with Wireless Interface

- Custom LCD screen with Cap touch button.
- Surface mounted
- RS485 Wired
- App connectivity via Bluetooth or Wi-Fi
- Wireless sensor connections
- Expanded monitoring and commissioning functions

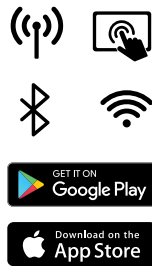

New Vent-Axia Connect App Control

- Bluetooth and Wi-Fi connectivity
- Wireless sensor connection and setup
- Comprehensive monitoring and commissioning
- Ease of control/setup

BMS connectivity provided on the unit as standard.

- Modbus - Bi-Directional via RS485
- SD card slot for easy transfer/recording of settings

Controls connectivity provided on the units as standard.

- 0-10 V input
 - 5 assignable inputs
 - 24V output to power sensor
- Switch inputs
 - 2 On/Off (Manual operation and Fire)
 - 3 Min/Max
 - 24V output to power sensor
- NO/NC Filter condition
- NO/NC Run / Fault indicator
- Twin external shutoff damper activation



24V CO₂ - Temperature and Humidity - Wired

Room-mounted CO₂ sensor with 0-10v signal output powered by an external 24V supply.

- Dimensions (H x W x D) (mm) 90 x 90 x 17
- 24V Power supply required
- Temperature range 0~60°C
- Relative humidity range 0-90% RH
- CO₂ range 0-2000PPM
- Compatible with standard single gang or surface mounted pattress box
- Status LED indicator for pairing, health check, faults & air quality traffic light index
- 0-10v Wired Communication

Model

24V CO₂ (+RH) 0-10V

Stock Ref

496432

Mains powered sensors



240V - Internal Temperature and Humidity - Wireless

Room-mounted humidity and temperature sensor for wired or wireless communication with a compatible system. Using an in-built RF 868 MHz (Wireless radio frequency), or RS485 (Wired connection) communication method whilst being powered by a local 240V supply.

- Dimensions (H x W x D) (mm) 90 x 90 x 17
- Power supply 240V
- Temperature range 0~60°C
- Relative humidity range 0-90% RH
- Wireless range 20m closed/100m open
- RF 868MHz Wireless or RS485 Wired communication
- Status LED indicator for pairing, health check, faults & air quality traffic light index

Model

240V Temp/RH RS485 & RF868

Stock Ref

496429



240V CO₂ - Temperature and Humidity - Wireless

Room-mounted CO₂ sensor for wired or wireless communication with a compatible system. Using an in-built RF 868 MHz (Wireless radio frequency), or RS485 (Wired connection) communication method whilst being powered by a local 240V supply.

- Dimensions (H x W x D) (mm) 90 x 90 x 17
- Power supply 240V
- Temperature range 0~60°C
- Relative humidity range 0-90% RH
- CO₂ Range 0-2000 PPM
- Wireless range 20m closed/100m open
- RF 868MHz Wireless or RS485 Wired communication
- Status LED indicator for pairing, health check, faults & air quality traffic light index

Model

240V CO₂ (+Temp & RH) RS485 & RF868

Stock Ref

496433



240V PIR Sensor - Wireless

Room-mounted PIR sensor for wired or wireless communication with a compatible system. Using an in-built RF 868 MHz (Wireless radio frequency), or RS485 (Wired connection) communication method whilst being powered by a local 240V supply. Room-mounted presence detector for min/max or on/off control. Wall or ceiling mounting

- Dimensions (H x W x D) (mm) 90 x 90 x 17
- Power supply 240V
- 5-25min run on timer
- PIR Range 3m
- Wireless range 20m closed/100m open
- RF 868MHz Wireless or RS485 Wired communication

Model

240V PIR Sensor

Stock Ref

496438



240V - 4 Speed Switch with Temperature and Humidity - Wireless

Room-mounted Speed Switch for wireless communication with a compatible system. Using an in-built RF 868 MHz (Wireless radio frequency) communication whilst being powered by a local 240V supply.

- Dimensions (H x W x D) (mm) 90 x 90 x 17
- Power Supply 240V
- Temperature range 0~60°C
- Relative humidity range 0-90% RH
- Wireless range 20m closed/100m open
- RF 868MHz Wireless
- Status LED indicator for pairing, health check and fault conditions
- Available in Black or White, image for illustration only

Model

240V Powered White Speed Switch

240V Powered Black Speed Switch

Stock Ref

496620

497693



240V - 4 Speed Switch with Temperature and Humidity - Wired

Room-mounted Speed Switch for wired communication with a compatible system. Using an in-built RS485 communication method powered by a local 240V supply.

- Dimensions (H x W x D) (mm) 90 x 90 x 17
- Power Supply 240V
- Temperature range 0~60°C
- Relative humidity range 0-90% RH
- Status LED indicator for pairing, health check and fault conditions
- Available in Black or White, image for illustration only
- RS485 Wired Connection

Model

240V Powered White Speed Switch

240V Powered Black Speed Switch

Stock Ref

496621

497697



IMPROVING INDOOR AIR QUALITY SINCE 1936

At Vent-Axia we pride ourselves on a long tradition of innovation. Driving this innovation is the desire to create healthier indoor environments in an energy efficient way.

The real world requirements of our customers drives us to develop best in class products that are easy to install, need minimal maintenance and provide quiet, energy efficient ventilation.

In addition, we have the largest sales and support teams of any ventilation company in the UK, dedicated to providing complete solutions with technical and design support.

Why choose Vent-Axia

Vent-Axia supplies ventilation to countries around the world, whose building regulations demand the most effective, sustainable and energy efficient ventilation solutions.

We are with you all the way

- Unparalleled customer service
- Industry leading design support
- Providing support and solutions on-site

With the widest distribution network of any manufacturer in the UK we pride ourselves on having products available when and where you need them.

Product Solutions

- Whatever the product category, we have the most energy efficient solutions available
- Unique solutions designed to fit in all buildings
- With absolute focus on the end user we work hard to produce the quietest, most comfortable products for occupiers



VENT-AXIA CONTACT NUMBERS

Free technical, installation and sales advice is available

| | |
|-------------------|--|
| Sales Tel: | 0344 856 0590 |
| Sales Fax: | 01293 565169 |
| Tech Support Tel: | 0344 856 0594 |
| Tech Support Fax: | 01293 532814 |
| Web: | www.vent-axia.com |
| Email: | sales@vent-axia.com |

Supply & Service

All sales made by Vent-Axia Limited are made only upon the terms of the Company's Conditions of Sale, a copy of which may be obtained on request. As part of the policy of continuous product improvement Vent-Axia reserves the right to alter specifications without notice.



Made in Britain

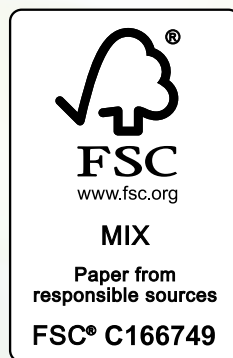

08/2025

402441