

**OPERATION AND  
MAINTENANCE  
INSTRUCTIONS**

**SINGLE PHASE  
TRANSFORMER  
SPEED CONTROLLERS**

**Vent-Axia®**

---

**IMPORTANT – PLEASE READ THESE INSTRUCTIONS FULLY  
BEFORE COMMENCING INSTALLATION.**

These instructions refer to the following models:

- 403089: 230 V a. c. 50Hz Maximum Operating Current: 2.0A** (max line fuse 4A)  
**403090: 230 V a. c. 50Hz Maximum Operating Current: 3.5A** (max line fuse 4A)  
**403091: 230 V a. c. 50Hz Maximum Operating Current: 6.0A** (max line fuse 8A)  
**403092: 230 V a. c. 50Hz Maximum Operating Current: 7.5A** (max line fuse 8A)  
**403093: 230 V a. c. 50Hz Maximum Operating Current: 9.0A** (max line fuse 16A)  
**403094: 230 V a. c. 50Hz Maximum Operating Current: 14.0A** (max line fuse 20A)

• **SAFETY**

All electrical installation must be undertaken by a suitably qualified and competent person and must be carried out in accordance with all relevant Statutory Requirements. Please check the details on the unit rating plate to ensure that the correct power supply (Voltage, Frequency and Phase) is available. Do not use the speed controllers with an incorrect power supply, overheating and failure of the circuit board will occur.

The controller must not be used when the ambient air temperature may exceed 40°C and where it is liable to be subjected to water spray.

• **INSTALLATION**

The controller is suitable for surface mounting only. Remove front cover and ensure back box is securely fixed to wall in a well-ventilated area. Route supply and load cables through `Knock-out` holes provided. If the controller is mounted on a conductive (metal) surface, that surface must be earthed.

• **GENERAL WIRING**

**Warning: The Control Equipment Must Be Isolated From The Power Supply During Installation And / Or Maintenance. The Equipment Must Be Earthed.**

Connect the power supply from the local isolator (via any appropriate controls if fitted) and the load supply to the back box via an appropriate cable gland. Refer to the wiring diagram and select the appropriate connections for the controller and / or other devices as being installed. Ensure that all earth connections have been made.

After completing and checking the connections to the controller replace the front cover ensuring that it is correctly seated in place. Ensure that all cable gland / grommet fixings and lid fixings are tightened correctly to prevent water ingress.

Transformers within these controllers are not short circuit proof and the necessary short circuit and overload protection must be provided.

**WIRING DETAILS**  
**MOTOR WITH EXTERNAL THERMAL CONTACTS**  
**230V 1PH 50Hz SUPPLY**

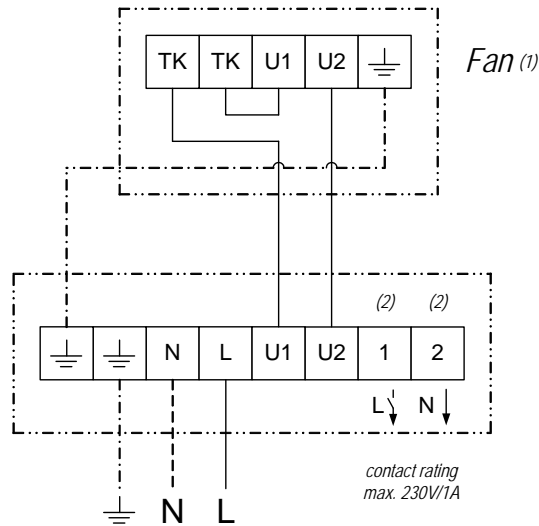

**WIRING DETAILS**  
**MOTOR WITHOUT EXTERNAL THERMAL CONTACTS**  
**230V 1PH 50Hz SUPPLY**

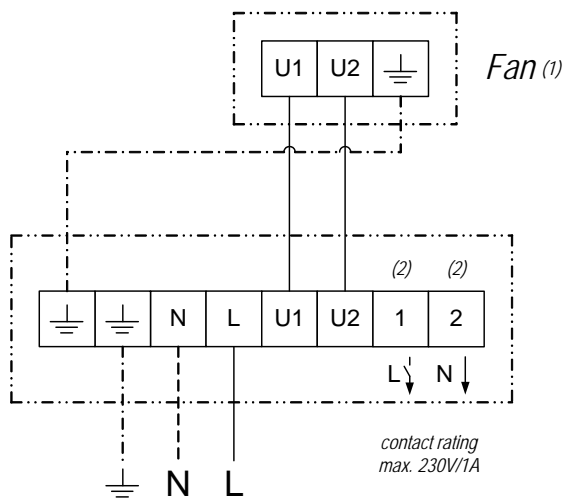

- (1) Fan terminals may vary with model. Refer to instructions with the fan for correct terminations.
- (2) Connections 1,2 only on units up to 7.5 Amps

**ALL WIRING MUST BE INSTALLED BY A SUITABLY QUALIFIED AND COMPETENT PERSON IN ACCORDANCE WITH CURRENT REGULATIONS!**

- **CHECK LIST**

- 1) Are all links and wiring complete (refer to wiring diagram)?
- 2) Are all fixings secured?
- 3) Are all protective circuit devices fitted and wired correctly?
- 4) Are all covers and gland fittings secure?
- 5) Are all earth connections secured?
- 6) Check that no hazard exists for persons in the locality of the fan.
- 7) Check that the current (amps) taken by the fan does not exceed the current shown on the rating plate of both fan and controller.

- **OPERATION**

Switch on the mains supply. Turn the control Knob from zero to required speed, the power on lamp will illuminate to show operation. Check required rotation of fan and ensure the fan operates correctly.

These controllers are not fitted with a reset function. In the event of fan failure it is possible for the fan to restart without warning. It is the installer`s responsibility to provide adequate safety devices to meet the requirements of all statutory safety regulations.

Several fans can be connected to the controller ensuring the total current of all motors does not exceed the nominal current of the controller

- **RESPONSIBILITY**

Vent-Axia Limited, as suppliers of the equipment cannot be responsible for the final installation and electrical connection of the product on site. We have made reasonable effort to offer guidance and assistance but the installer and electrical contractor on site have a responsibility for ensuring the equipment is safely and securely installed and electrically / mechanically safe in accordance with statutory requirements.

The controllers are supplied as a component to be incorporated into a ventilation system. The final complete systems installation that includes the controllers MUST meet all relevant directives.

- **GUIDELINES FOR EMC COMPATIBLE INSTALLATIONS**

Compliance with EMC directives is only ensured when the product has been correctly installed.

Safety Earthing must always take precedence over additional earthing required to maintain EMC compliance.

Care must be taken when installing cables; those used for inductive loads must be separated from more sensitive cables, e. g. Sensor Cables, Personal Computers and CCTV.

These controllers have been designed to operate without the need to use shielded cables between the controller and fan. There may be instances where shielded cable is required, e. g. when sensor cables are in close proximity, and under these circumstances the shielding should be bonded at both ends.

## **Vent-Axia Limited Guarantee**

Applicable only to products installed and used in the United Kingdom. For details of guarantee outside the United Kingdom, contact your local supplier.

Vent-Axia Limited guarantees its products for one year from the date of purchase against faulty material or workmanship- In the event of any part being found to be defective, the product will be repaired, or at the Company's option replaced, without charge, provided that the product:

- 1) Has been installed and used in accordance with the instructions given with each unit.
- 2) Has not been connected to an unsuitable electricity supply. (The correct electricity supply voltage is shown on the product rating label attached to the unit.)
- 3) Has not been subjected to misuse, neglect or damage.
- 4) Has not been modified or repaired by any persons not authorised by the company.

If Claiming Under Terms of Guarantee.

Please return the complete product, carriage paid to your original supplier or nearest Vent-Axia Limited Centre, by post or personal visit. Please ensure that it is adequately packed and accompanied by a letter clearly marked "Guarantee Claim! Stating the nature of the fault and providing evidence of date and source of purchase.

As part of the policy of continuous product improvement Vent-Axia Limited reserves the right to alter specifications without notice.

# ***Vent-Axia***<sup>®</sup>

Head Office: Fleming Way, Crawley, West Sussex, RH10 9YX.

**UK NATIONAL CALL CENTRE**, Newton Road, Crawley, West Sussex, RH10 9JA  
SALES ENQUIRIES:           Tel: 0844 8560590           Fax: 01293 565169  
TECHNICAL SUPPORT:       Tel: 0844 8560595           Fax: 01293 539209

For details of the warranty and returns procedure please refer to [www.vent-axia.com](http://www.vent-axia.com) or write to Vent-Axia Ltd, Fleming Way, Crawley, RH10 9YX