

Vent-Axia®

Lo-Carbon MVDC & SENTINEL MULTIVENT RANGE

VENTILATION SYSTEMS

Installation and Wiring Instructions

Original instruction

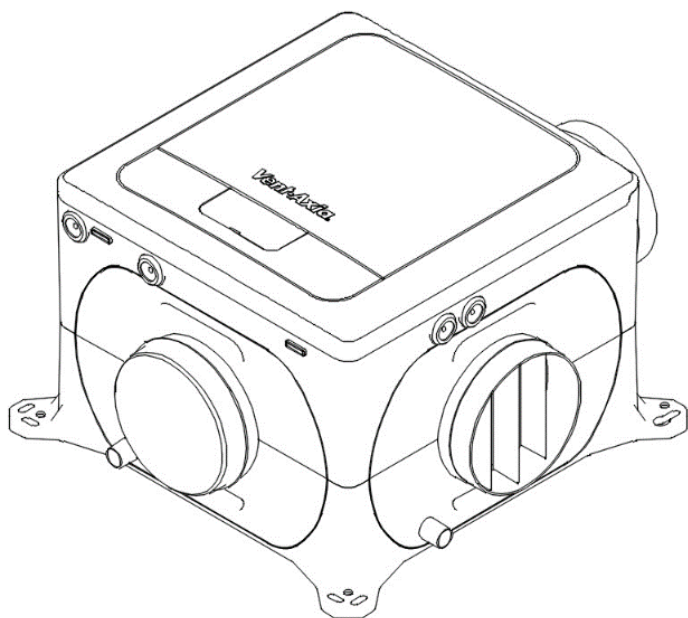

Stock Ref. N°

Lo-Carbon Multivent MVDC-MS	437634C
Lo-Carbon Multivent MVDC-MSH	443298B
Lo-Carbon Multivent MVDC-MSH UNIFLEX	498502

Lo-Carbon Sentinel Multivent H	445655B
Lo-Carbon Sentinel Multivent HX	495360
Lo-Carbon Sentinel Multivent HX CO ²	495361

Lo-Carbon Sentinel Multivent Plus H	407849A
Lo-Carbon Sentinel Multivent Plus HX	495362
Lo-Carbon Sentinel Multivent Plus HX CO ²	495363

(Ventair)	
Lo-Carbon Sentinel Multivent Plus H	496186

X-Units have wireless controls and Bluetooth capability.



DOWNLOAD THE APP HERE:



CE

UK
CA

IPX2





**PLEASE READ THESE INSTRUCTIONS CAREFULLY
BEFORE COMMENCING INSTALLATION OR OPERATION.**

PLEASE RETAIN THESE INSTRUCTIONS WITH THE PRODUCT.

Installation and Wiring Instructions for the Multivent Multi-Speed Extract Fans.



IMPORTANT: READ THESE INSTRUCTIONS BEFORE COMMENCING THE INSTALLATION

- Do not install this product in areas where the following may be present or occur:
 - Excessive oil or a grease laden atmosphere.
 - Corrosive or flammable gases, liquids or vapours.
 - Subject to direct water spray from hoses.
 - Ambient temperatures higher than 40°C and lower than -20°C.
 - Possible obstructions that may hinder access to or removal of the unit.
- All wiring must be in accordance with the current IET wiring regulations BS7671, or appropriate standards of your country. Installation should be inspected and tested by a suitably qualified person after completion.
- Ensure the mains supply (voltage, frequency and phase) complies with the rating label.
- The unit should be provided with a local double pole fused spur fitted with a 3A fuse having a contact separation of at least 3mm.
- Units showing  on the rating label incorporate an earth connection for functional purposes only.
- Units showing  on the rating label have a Protective Earth.
- Precautions must be taken to avoid the backflow of gases into the building from the open flue of gas or other fuel-burning appliances.
- This appliance is not intended for use by persons (including children) with reduced physical, sensory or mental capabilities, or lack of experience and knowledge, unless they have been given supervision or instruction concerning use of the appliance by a person responsible for their safety.
- Young children should be supervised to ensure that they do not play with the appliance.
- Cleaning and user maintenance shall not be made by children
- The installer is responsible for the installation and electrical connection of the unit on site. It is the responsibility of the installer to ensure that the equipment is safely and securely installed and left only when mechanically and electrically safe.
- All regulations and requirements must be strictly followed to prevent hazards to life and property, both during and after installation, and during any subsequent servicing and maintenance.
- Certain applications may require the installation of sound attenuation to achieve the sound levels required.
- The unit must not be connected directly to a tumble drier.
- The exhaust grille should be located in accordance with building regulation and be at least 300mm away from any flue outlet.
- This product and associated duct installation should be carried out in accordance with the Domestic Ventilation Compliance Guide.

Models that support Radio and Bluetooth communication the below applies

- Bluetooth variants contain FCC ID: S9NSPBTLERF
- Bluetooth LE: -12dBm EIRP (63µW), nominal 2450MHz.
- Bluetooth v4.1 compliant
- Bluetooth and radio variants obtained RED certificate: No. 0051-RED-0011 REV. 0
- Zirconia Wireless: -14dBm EIRP nominal 868MHz.
- The manufacturer hereby assures that this type of Bluetooth radio and 868MHz radio equipment complies with RED Directive 2014/53 / EU

The full text of the EU Declaration of Conformity can be found at the following URL:

<https://www.vent-axia.com/range/centralised-mechanical-extract-ventilation-mev>

INTRODUCTORY NOTES

The MVDC & Sentinel Multivent units are designed for simultaneous extract ventilation of multiple wet rooms such as bathrooms, kitchens and toilets. The units use a highly efficient backward curved centrifugal motor impeller set and are designed for continuous 24-hour use.

Depending on the model, they feature either 3 or 4 settable speeds and can be configured to change speed based on a wide range of sensor or control inputs as depicted below

Model	MVDC-MS	MVDC-MS H	SMV H	SMV HX	SMV HX Co2	SMV Plus H	SMV Plus HX	SMV Plus HX Co2
Speeds	3	3	4	4	4	4	4	4
Max airflow m3/hr (0Pa)	430	430	463	463	463	573	573	573
Switched Live Input (LS)	Yes	Yes	Yes	Yes	Yes	Yes	Yes	Yes
RS485 Connectivity	No	No	Yes	Yes	Yes	Yes	Yes	Yes
Analogue Input 0-10V	Yes	Yes	Yes	Yes	Yes	Yes	Yes	Yes
Digital Input	Yes	Yes	Yes	Yes	Yes	Yes	Yes	Yes
Humidity Sensor	No	Yes	Yes	Yes	Yes	Yes	Yes	Yes
CO2 Sensor	No	No	No	No	Yes	No	No	Yes
Wireless Receiver	No	No	No	Yes	Yes	No	Yes	Yes

The units can be precisely programmed to determine how they respond to changes in sensor values or the status of the various signal inputs. The units will run at a normal flowrate until a sensor or input change causes it to change speed. In the case of the Switched Live and Digital inputs the units will perform a step change in speed to the appropriate new level. In the case of the Analogue inputs, Humidity Sensor and CO2 sensor the unit can be programmed to give a proportional response to the change in conditions.

INSTALLATION

Position the unit, taking into consideration the position of the rooms to be ventilated, the exhaust position and the electrical services. Ensure there is adequate access for installation and maintenance.

If the unit is sited in the heated void of the dwelling a condensate drain should not be necessary. When sited in a cold void, consideration should be given to fitment of a condensate drain. Alternatively, the unit and ducting can be externally insulated to minimize condensation within the units housing.

To reduce the system resistance in your duct system, and therefore lower the speed, power consumption and noise of the fan, follow these guidelines:

- 1.1. Keep the length of duct runs to a minimum, particularly the exhaust duct run.
- 1.2. If you need to use flexible ducting, make sure that it is fully extended and not crushed, sagging or torn.
- 1.3. Try to minimize the use of diffusers/valves by having similar length duct runs to the inlets.
- 1.4. The bend radius (measured to the inside of the bend) should be at least 1x the duct diameter.
- 1.5. Avoid having any bends, filters or other obstructions within 250mm of the fan inlets and outlet.
- 1.6. Set the valves to their maximally opened positions for a minimal pressure drop.

Securely mount the unit through the mounting holes on the casing using appropriate fixings for the mounting substrate. It is recommended that anti-vibration mounts, acoustic mat or rubber bushes are used.

Fixings (not supplied) to be capable of securing 4 x the weight of the unit. Unit weight: 4.1kg

To maintain the IPx2 rating of the unit, the unit must **NOT** be mounted with the cover removal slots facing upwards, or at an angle where they are visible from above. All other orientations are acceptable.

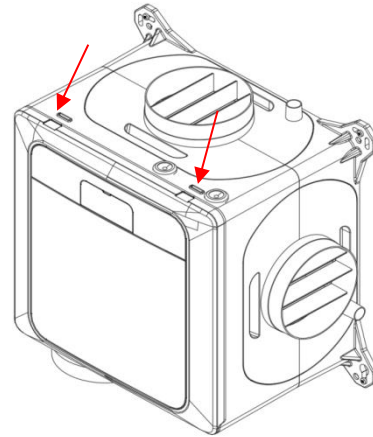
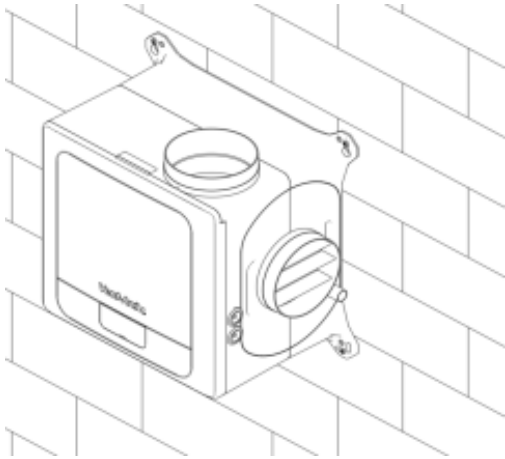

See the dimensional details below for the mounting hole positions.
-Spigot diameters are 125mm

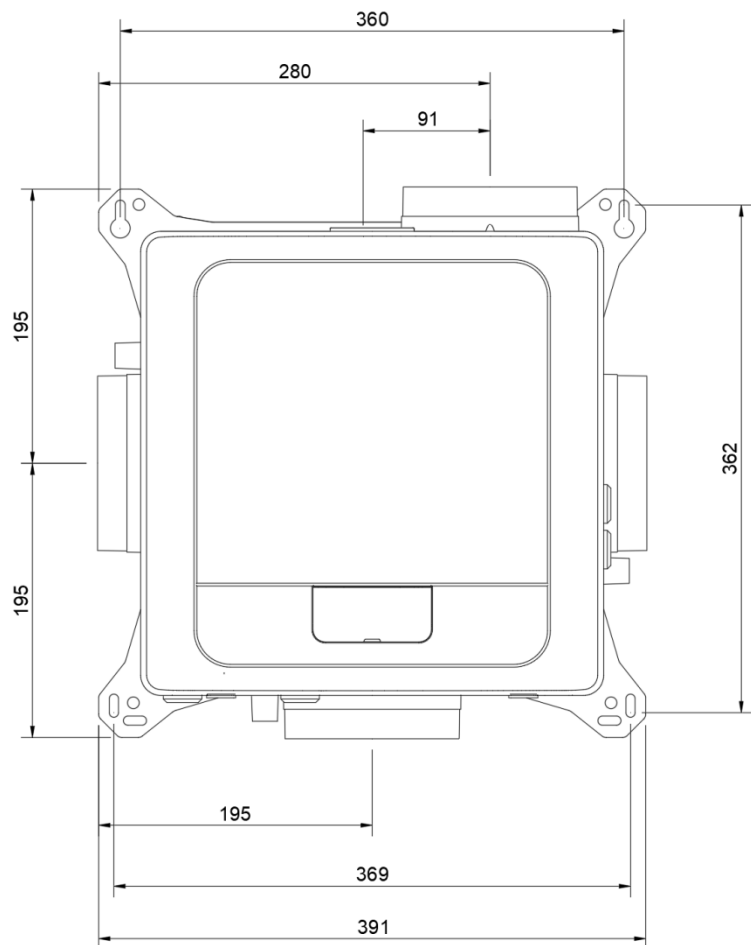
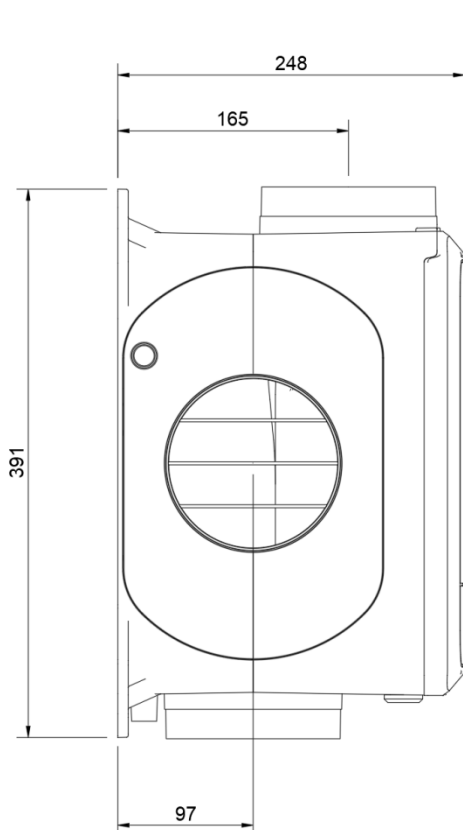

- i. **Base mounted Installation** with ducting radiating out horizontally.

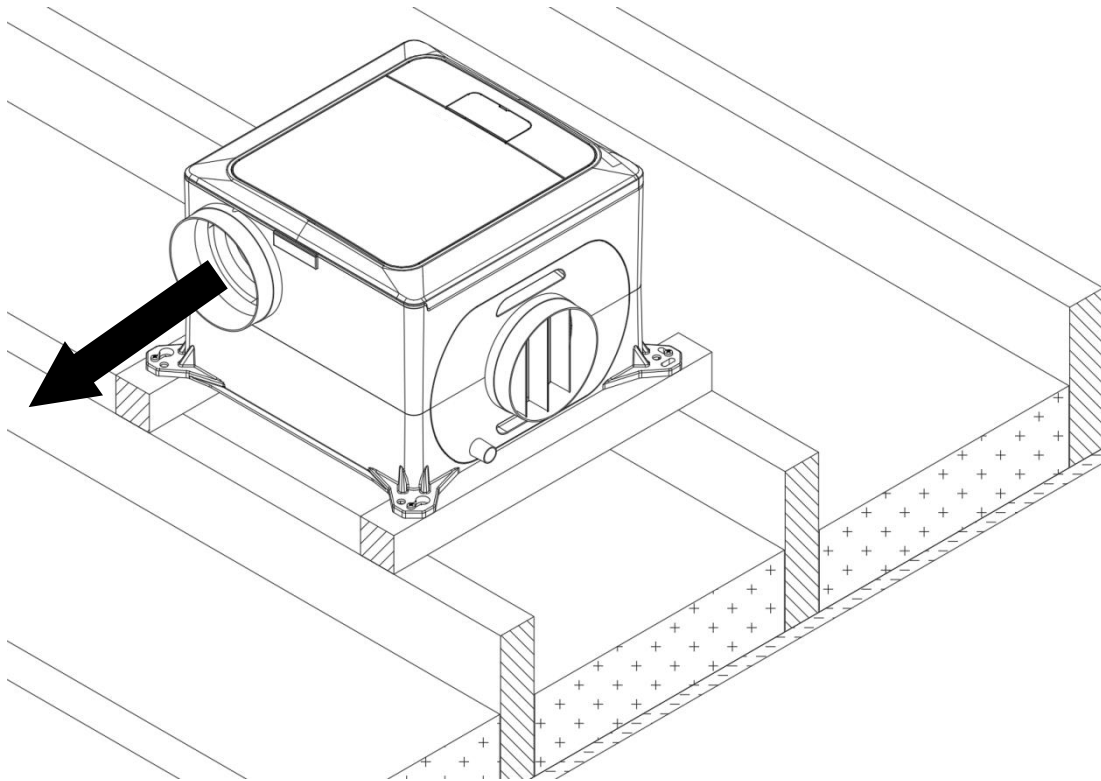

- ii. **Vertically mounted Installation** with the exhaust spigot at top. The electrical connections must come out of the bottom of the unit in order to maintain the water ingress protection.

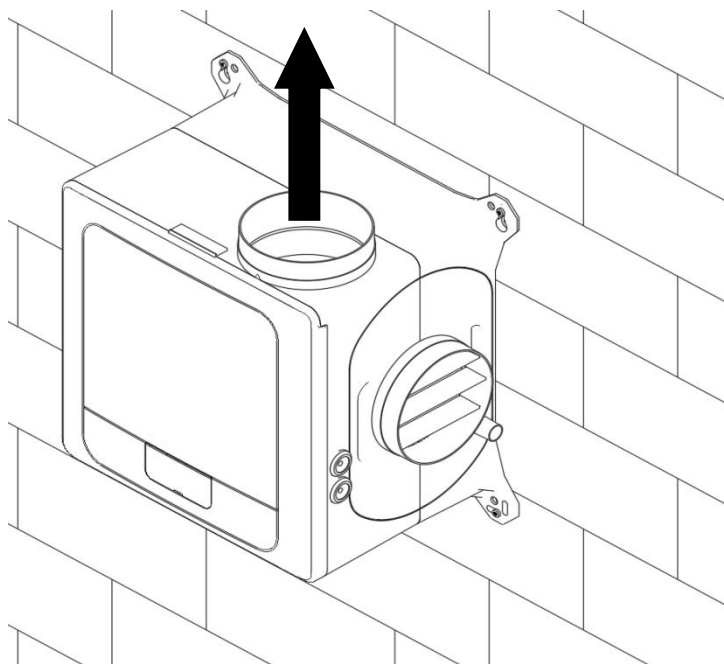

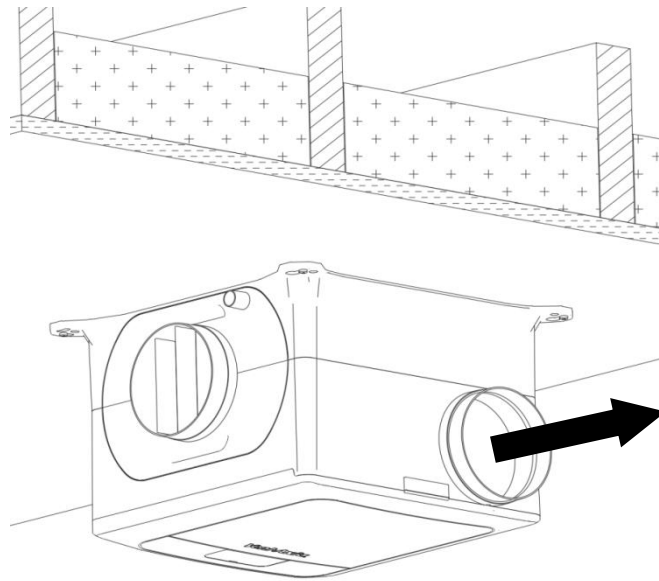

iii. **Ceiling mounted Installation** with ducting radiating out horizontally.



WIRING



WARNING:
THE UNIT AND ANCILLARY CONTROL EQUIPMENT MUST BE ISOLATED FROM THE POWER SUPPLY DURING THE INSTALLATION / OR MAINTENANCE. THIS UNIT MUST BE EARTHED.

1. To remove the cover, use a coin or similar; depress the retaining tabs via the slots in the side of the unit.
2. With the power off, connect a suitable mains power cable from a switched, fused spur to the screw terminal block. Use the cable clamps and clip provided to secure the lead.
3. Two mains voltage Live Switched (LS1 and LS2) connections are provided and can be used to trigger a change in speed. Common inputs would be from a bathroom lighting circuit. When commissioning the unit, a delay on timer and an overrun timer can be selected and adjusted in the software using the buttons and screen. See Commissioning section on page 9 of this document for details.
4. The switched live output (230Vac) from any other switch or controller, (such as a simple latching pull cord or push-button switch, humidistat or PIR detector) can be connected to the LS terminal instead of connecting to a lighting circuit.
5. Important: Use 4-core, low voltage, twisted pair, telecoms type cable for accessories (Vent-Axia part number 459931). Accessories are connected via the IO (Input Output) PCB; see the Low Voltage Connections diagram. Use the cable clamp and grommet provided.
6. There are no delay-on or overrun timers with the volt-free connection as the controller should determine when the fan is running at Boost or Normal speeds. Use the LS connection described above if you want a timer.
7. Units showing  on the rating label incorporate an earth connection for functional purposes only.
8. Units showing  on the rating label have a Protective Earth.

CONNECTION DIAGRAM

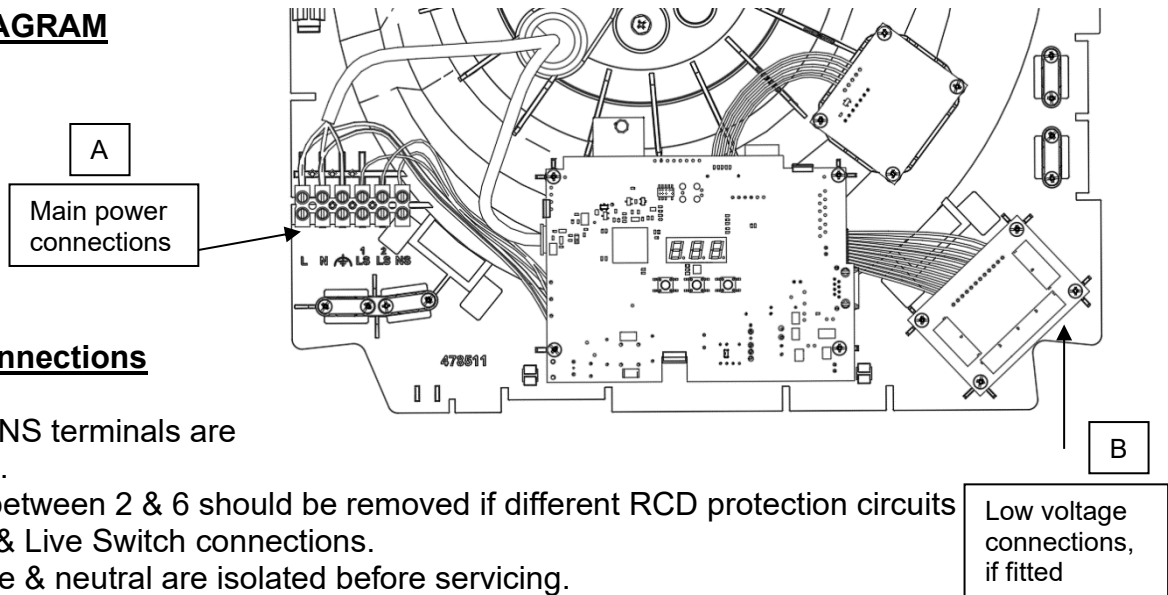





A: Main power connections

The LS1, LS2 and NS terminals are electrically isolated.

Note: Neutral link between 2 & 6 should be removed if different RCD protection circuits for mains power a & Live Switch connections.

Note: Ensure all live & neutral are isolated before servicing.

- Units showing  on the rating label incorporate an earth connection for functional purposes only.
- Units showing  on the rating label have a Protective Earth.

Connection	Description
1	L
2	N
3	
	
4	LS1
5	LS2
6	NS
7	N + NS

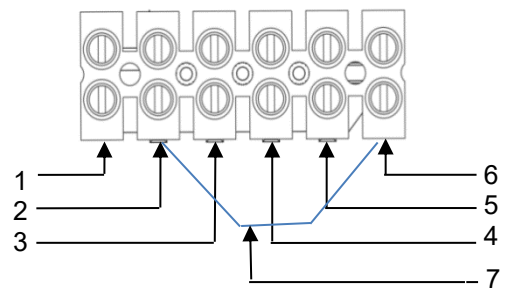

B: Low voltage connections

For best performance use 4-core, low voltage, twisted pair, telecoms type cable for accessories.

(Available from Vent-Axia part number 459931).

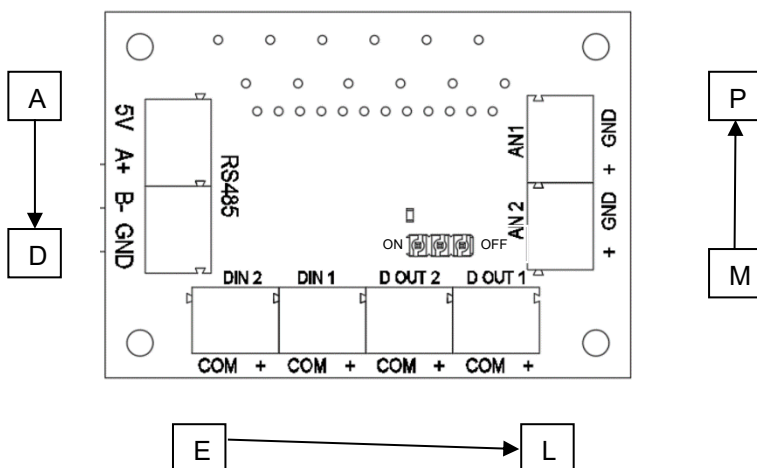

Position	Label	Description	Action
A	RS485	5V	5V Output, Max 250mA
B		A+	Data
C		B-	Data
D		GND	Ground
E	D IN 2	COM	Digital input common
F		+	Digital input 2
G	D IN 1	COM	Digital input common
H		+	Digital input 1
I	D OUT 2	COM	Digital output common
J		+	Digital output 2
K	D OUT 1	COM	Digital output common
L		+	Digital output 1
M	AN 2	+	Analog input 2
N		GND	Ground
O	AN 1	+	Analog input 1
P		GND	Ground

RS485 Wired inputs

The RS485 terminals are used to connect compatible sensors and switches.

The connection allows sensors be daisy chained to simplify wiring. The maximum length of cable run from the unit is limited to 250m. Once accessories are wired to the unit, they must be paired to the unit to function correctly.

RS485 Wired input connection diagram

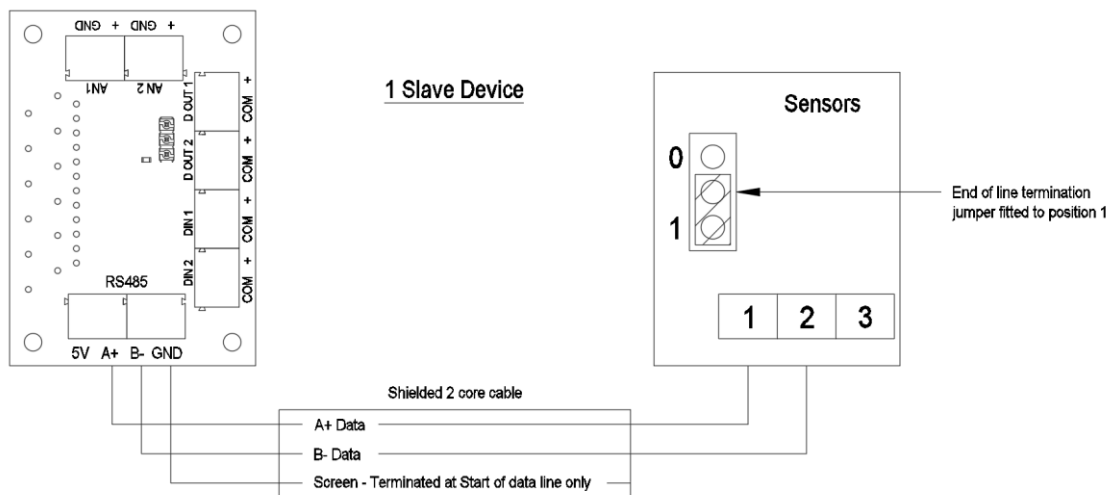

2+ Slave Devices

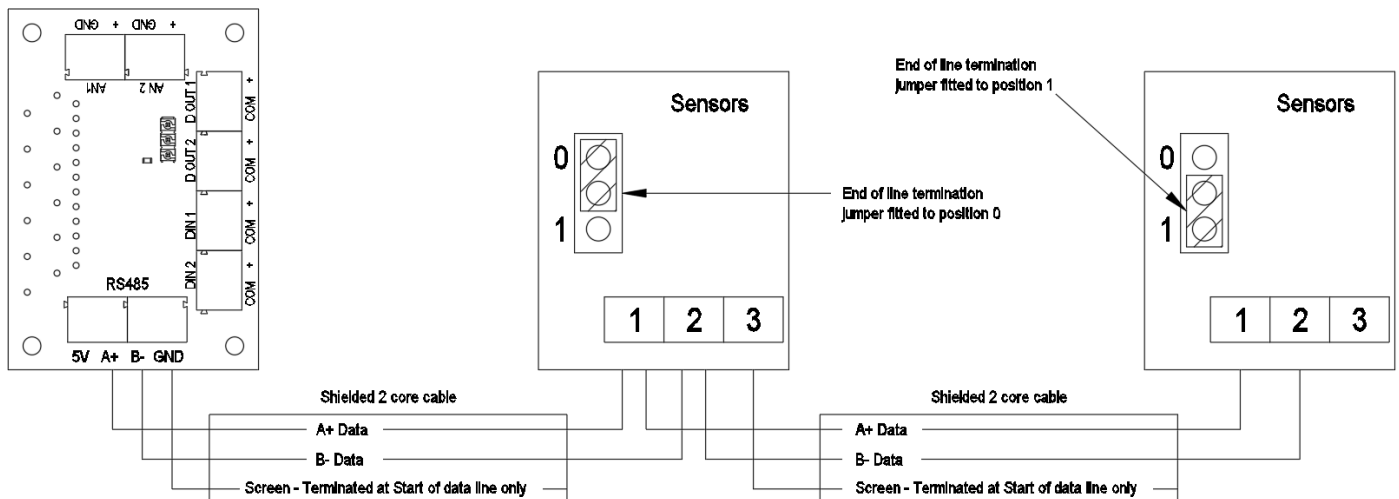

RF868 Wireless inputs

Units that contain a Wireless receiver can be paired with compatible sensors, these can be mains or battery powered depending on the sensor.

A maximum of 15 wired and wireless sensors can be connected to a single unit.

Pairing sensors

To pair the unit with a wired or wireless sensor:

- Press the **Mode** button to turn on the display.
- Press and hold the **Mode** button until the LED illuminates **solid White**
- Release the mode button, the LED will **flash White** to indicate that it is in pairing mode. The unit will remain in pairing mode for 1 hour, or until the mode button is pressed again.
- Activate the pairing function on the sensor to be paired (see the instructions that came with the sensor).
- When a sensor is paired the total number of paired devices is displayed on the unit.

Removing sensors

To remove paired sensors, the unit must be reset. Caution, this will reset all values back to factory default.

- Press the **Mode** button to turn on the display.
- Press and hold the **Mode** button until the LED illuminates **solid Red**
- Release the mode button, the LED will **stay Red**.
- Pressing the **Mode** button again will confirm the reset command. If a reset is not wanted, leave the unit until the command times out and the LED turns off.

C: Sensor priorities

The unit set the motor speed based on the source in the following order:

- User override
- LS inputs (1 and 2)
- Digital inputs (1 and 2)
- Sensor override: *The Sensor override action is decided based upon the Sensor input (Humidity Sensor, Co2 sensor, Analog inputs) whichever sets the motor to run in Highest speed.*
- Default speed (run in normal speed)

Note: At each priority state, if more than one inputs are active (e.g. Digital input 1 and 2 are active), then motor will always run at a speed from the input which has highest speed level.

Example - LED Fault Indicator Connection (MVDC MS/H do not have this facility)

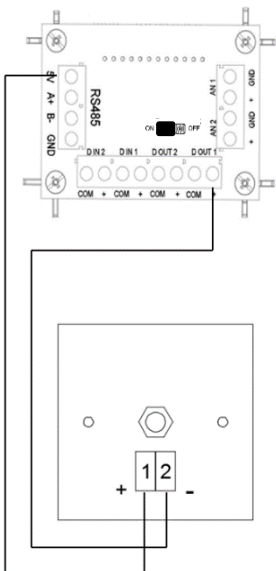

Example - LED Boost Indicator Connection (MVDC MS/H do not have this facility)

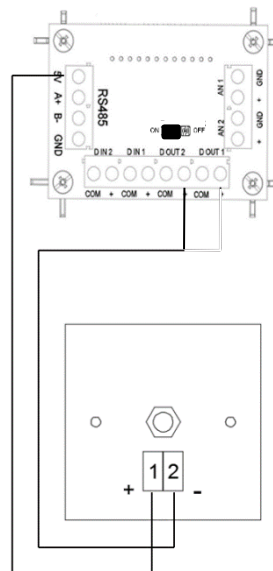

Low Voltage Switch's – Boost & Low Speed

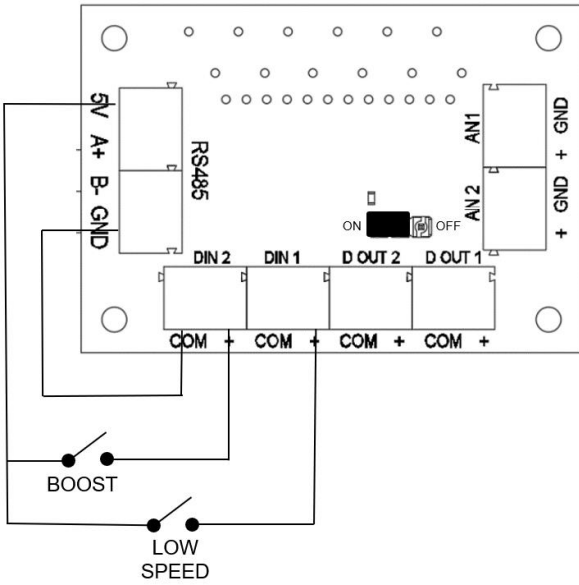

FEATURE DESCRIPTIONS

If compatible, the unit can be controlled via the Bluetooth linked App. This is only available on Sentinel-X Wireless units.

Comfort mode

If Comfort mode is enabled the unit will behave as follows to all LS inputs:

Trigger	Action
LS input active less than 5 minutes	No action (continue to run at Normal speed)
LS input active more than 5 minutes but less than 20 minutes	Once LS input is removed, fan will run at user selected speed for the length of time LS was present plus the set over-run time (if over run is enabled).
LS input active more the 20 minutes	Unit will Boost after 20mins. Once LS input is removed, fan will run at user selected speed for 20 minutes plus the set over-run time (if over run is enabled).

The above applies to all LS inputs. The times are not adjustable by the user.

Delay On

A delay can be set so that the unit will not respond to an input until after the set delay has elapsed, applies to LS inputs only.

Overrun Timer

The unit can be set to run for a defined period after the input is removed, applies to LS inputs only.

Humidity – Rapid rise*

Rapid Rise humidity response functions to detect rapid rises in humidity when the ambient %RH is under the threshold setting. If a rapid rise is detected the fan will boost until the humidity lowers again.

Humidity – Ambient response*

When ambient response is enabled the threshold set point is modified based on the ambient temperature. This helps to prevent nuisance boosting of the unit as temperatures changes during the day.

Humidity – Threshold*

The unit will boost when the RH is above the threshold set point.

CO2 threshold Boost / Purge*

The unit will go to Boost / Purge when the detected CO2 level exceeds the set thresholds.

Analogue inputs

Both analogue inputs have adjustable low and high trigger voltages within the 0-10V range. The response to being above or below either of the threshold voltages is user settable.

Note: The display doesn't show a decimal point, for example at threshold voltage of 5.2V, is displayed as "52" on the unit.

Digital Inputs

The unit can be set to change speed (selectable), based on whether the digital inputs are above or below the threshold voltage. See the table of Low Voltage Connections for details.

Display Lock

To protect the settings on the MEV unit a pin code can be enabled via the main menu.

Once the lock function has been enabled the Pin code can be set.

The 3-digit pin is A to F, 0 to 9, and the **default is LoC**.

*** If external RH or CO2 sensors are fitted via RS485, they will have priority over the internal sensors, their value will also be displayed on the unit in preference to the internal sensor.**

UNIT ADJUSTMENT

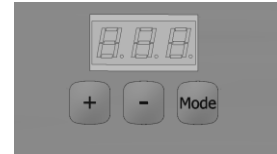

1. Commissioning and configuration on all products is supported by the 3 digit user interface and associated push buttons.
2. When powered on, the unit will display the firmware revision number, after a few seconds the unit will display the first option in the menu structure (see below).
3. The display will enter standby mode after defined timeout (default 10min) or user selects “END” option in menu, press the Mode button to turn the display back on.
4. Changes to the settings can be made via the **+** and **-** buttons, the Mode button will accept changes and move onto the next menu option.
5. When setting the speeds, there is an internal logic: Low<Normal<Boost<Purge. I.e., Boost is always higher than Normal.
6. The actions for each of the Live Switched (LS), inputs are selectable. The setting for delays and over run timers are applicable to all inputs.
7. To restore factory settings, Press and hold “Mode” button for 10 seconds

Wireless units can be commissioned via the Bluetooth connected App.

Links to the App are shown on the cover page of this manual. The App must be installed before a connection to the unit is possible.

Bluetooth Pairing

To enable Bluetooth pairing on the unit:

- Press the **Mode** button to turn on the display
- Press and hold the **Mode** button until the LED illuminates **solid Blue**
Release the mode button, the LED will **flash Blue** to indicate that it is in pairing mode.
- Follow the instruction on the App to connect to the unit.

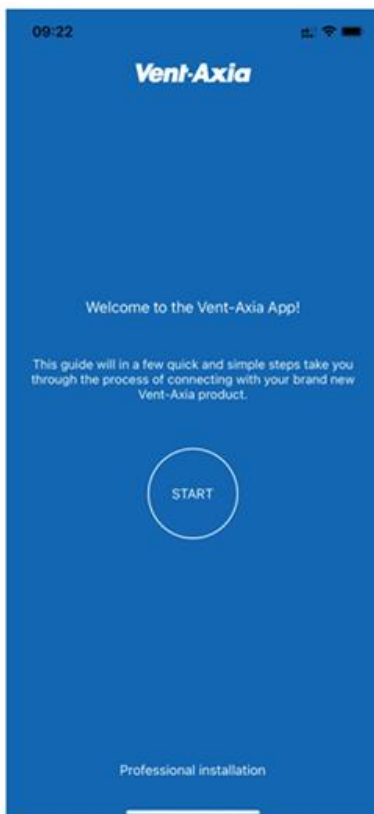

User Configurable Parameters

Display text	Function	Selections	Default
Lxx	Low speed	1 to 97% motor speed	10%
nxx	Normal speed	2 to 98% motor speed	25%
bxX	Boost speed	3 to 99% motor speed	35%
Pxx	Purge Speed	4 to 100% motor speed	50%
LS1	Live switch 1	Low, Boost or Purge speed	Low
LS2	Live switch 2	Low, Boost or Purge speed	Boost
LS3	Live switch 1&2	Low, Boost or Purge speed	Purge
c-n	Comfort mode	Comfort mode - yes or no	No
d-n	Delay On	Delay on - yes or no	No
dxx	Delay On time	Delay to boost duration 1 to 60 minutes	10m
o-n	Overrun	Overrun - yes or no	No
oxx	Overrun time	Overrun duration 1 to 60 minutes	10m
r-y	Humidity – Rapid Rise	Rapid rise - yes or no	No
A-n	Humidity – Ambient Response	Ambient response - yes or no	No
hxx	Humidity threshold	Ambient response threshold 40 to 90% RH	70%
C2b	CO ₂ threshold boost	Boost threshold 650 – 4950 PPM in increments of 50	100
C2P	CO ₂ threshold purge	Purge threshold 700– 5000 PPM in increments of 50	120
A1LA	Analogue 1 - low action	Low, Normal, Boost or Purge speed	Low
A1HA	Analogue 1 - high action	Low, Normal, Boost or Purge speed	Boost
A1tL	Analogue 1 - low threshold	Analogue Input Threshold Low 1 - 99	15
A1tH	Analogue 1 - high threshold	Analogue Input Threshold High 1 - 99	75
A2LA	Analogue 2 - low action	Low, Normal, Boost or Purge speeds	Low
A2HA	Analogue 2 - high action	Low, Normal, Boost or Purge speeds	Boost
A2tL	Analogue 2 - low threshold	Analogue Input Threshold Low 1 - 99	15
A2tH	Analogue 2 - high threshold	Analogue Input Threshold High 1 - 99	75
D1	Digital input 1 Action	Low, Boost or Purge speeds	Low
D2	Digital input 2 Action	Low, Boost or Purge speeds	Boost
unl	Unlock code	Turn on/off the menu lock	---
PIIn	Display Pin	3 characters A to 9	LoC
dtxx	Display time	Adjust how long the display is illuminated	10m
rot	Rotate display	Invert the display	rot
hu	Humidity	Show the current internal humidity	%
tu	temperature	Show the current internal temperature	°C
CO ₂	CO ₂	Show the current CO ₂ level	PPM
rEf	Calibration reference value	40 to 200	40 (400ppm)
cAL	Calibration Mode	Y to enable	n
end	end	End of menu (loop to start)	

If the unit being commissioned is not fitted with the relevant hardware, the associated menu options will not be available.

CO₂ Calibrations

The following instructions describe the actions required to calibrate the CO₂ sensors used within the MEV unit (if fitted), and the Room Sensor accessories in two steps:

1. MEV Unit – Internal sensor

Step 1 can be done by either Exposure method or Measurement method, the baseline step 2 is actioned once either step 1 options are complete.

1.1 Exposure method step 1

Exposure method assumes that the outside CO₂ concentration is 400 PPM in the rooms in which the MEV extracts air from, the Rooms must be well ventilated by opening any external windows and doors for 10 to 15 minutes. The room must remain well ventilated and unoccupied until after the baseline step has been actioned.

1.2 Measurement method step 1

If the Engineer has a calibrated CO₂ meter, they simply need to measure the CO₂ in accordance to the CO₂ meters instructions within the rooms the MEV extract air from. Measurement taken from each room should be recorded and then averaged.

Example: Room 1 – 450ppm + Room 2 440ppm + Room 3 – 460ppm = 1350ppm / 3 = 450ppm
The averaged value is then used during the baseline step.

1.3 Baseline step 2

MEV On-Board display method

Within the MEV menu there is rEF which has a default value of 40 (=400ppm), if using the Exposure method of calibration this does not need to be changed.

For the Measurement method of calibration, the value within rEF should be changed to the recorded average PPM, using the example value this would be 45 (=450ppm).

With the rEF value set as required, the user should navigate to the cAI menu and use the up/down arrow to select y (=Yes). The status LED will start blinking Magenta colour signifying the start of the calibration, the MEV will repeatedly read the CO₂ sensor for 3 minutes to obtain a stable reading, once the status LED stops flashing the Calibration value has been set.

MEV Mobile App method

Once the app is connected to the MEV navigate to the CO₂ screen from the home screen. On the CO₂ screen enable Set CO₂ calibration at the bottom of the page.

An additional slide bar will appear with a default value set to 400ppm, if using the measurement method, the value should be changed to match the measured averaged recorded PPM, using the example value this would be 450ppm. For the Exposure method the value should be unchanged at 400ppm.

With the value set the Save button should be pressed in the top right of the screen to start the calibration process, the status LED will start blinking Magenta colour signifying the start of the calibration, the MEV will repeatedly read the CO₂ sensor for 3 minutes to obtain a stable reading, once the status LED stops flashing the Calibration value has been set.

2. Room Sensor Calibration

The Room sensor can only be calibrated using the Exposure method and will have Auto Background Calibration (ABC) by default.

2.1 Exposure method Step 1

Exposure method assumes that the outside CO₂ concentration is 400 PPM in the room which the Sensor is fitted, the room must be well ventilated by opening any external windows and doors for 10 to 15 minutes. The room must remain well ventilated and unoccupied until after the baseline step is complete.

2.2 Baseline method – Step 2

With the Room sensor paired to the system the status LED will be Green when the button is pressed, in this condition the button should be pressed and held (8 Seconds) until the status LED is Magenta, the button should then be released and the LED will be blinking Magenta to signify the start of the calibration process, the room should be unoccupied once the calibration has started and should remain so for 5 minutes. During the calibration process the Room sensor will repeatedly read the CO₂ sensor for 3 minutes to obtain a stable reading, once the status LED stops flashing the Calibration value has been set.

FAULT CODES

If the MEV unit detects a fault it will display an error message on the HMI display:

Fault Code	Description	
F01	Control fault – Unit failed startup check	Turn the power off and on again.
F02	Motor Fault – No RPM (MVDC MS/H don't have this facility)	Check that the impellor has free movement. Check internal motor wiring.
F03	Humidity/Temp sensor Fault – No value – internal sensor	Contact tech support, scroll part.
F04	CO ₂ sensor Fault – No value – internal sensor	Check the internal wiring to the sensor
F05	Temp or Humidity sensor connected via RF/RS485 is offline/Lost	Check that the sensor is turned on. Re-pair the sensor to the unit, see page 10.
F06	CO ₂ sensor connected via RF/RS485 is offline/Lost	Check that the sensor is turned on. Re-pair the sensor to the unit, see page 10.
F07	4-Way Speed Switch	SSU offline or lost – Please reconnect
F08	AIM (Alarm Interface Module)	AIM Sensor triggered / offline or lost – Verify Issue

If a fault persists, contact your local technical support, see the back cover of this manual for details.

SPARE PARTS



WARNING: THE FAN AND ANCILLARY CONTROL EQUIPMENT MUST BE ISOLATED FROM THE POWER SUPPLY DURING PART REPLACEMENT.

1. Individual faulty parts should not be replaced due to complexity of assembly. Only the full scroll assembly is replaceable.
2. To remove the scroll assembly, isolate the power, then use a coin or similar to depress the cover retention clips and remove the cover.
3. Disconnect and remove the power supply and signal leads.
4. Remove the scroll assembly by unscrewing the two screws and unclipping the clips in the opposite two corners and lift the scroll assembly out of the housing.
5. The fan has sealed for life bearings, which do not require lubrication. Expected service life is at least 45,000 hours continuous running.
6. Upon reassembly, check all fixings are tight and secure.

For a replacement Scroll assembly please contact:
Vent-Axia Technical support
+44 (0)344 856 0594
Email: vatechsupport@vent-axia.com

Please take note of the model's name and number to ensure the correct scroll assembly is supplied.

ACCESSORIES

	MVDC-MS / H	SMV H SMV PLUS H		SMV HX / CO2 SMV PLUS HX / CO2	
Sensor/Controller Name / Function	Wired 0-10V	Wired 0-10V	Wired RS485	Wired RS485	Wireless RF868
Temp/RH	496428 (240V)	496428 (240V)	496429 (240V)	496429 (240V)	496429 (240V) 496431 (Battery)
CO2 (+RH) 0-10V	496432 (240V)	496432 (240V)	496433 (240V)	496433 (240V)	496433 (240V)
PIR	-	-	496438 (240V)	496438 (240V)	496438 (240V)
AIM (Alarm interface module)	-	-	-	-	496441 (240V)
External Temp/RH battery powered	-	-	-	-	496442 (Battery)
MEV Controller RH RS485 & RF868	-	-	496442 (240V)	496442 (240V)	496442 (240V)
Speed Switch 4 way	-	-	496621 (240V)	496621 (240V)	496620 (240V) 496437 (Battery)

All units	
Sensor/Controller Name	Part Number
4-way analogue speed switch	496622
Timespan controller	563519
Air Quality Sensor	563506
Ambient response Humidity sensor	563550
Ecotronic Humidity sensor	563532
ThermoSwitch	563502
7 Day timer switch	563515
Visionex PIR	459623
3-pole Isolator switch	563518
Remote delay timer	457986
Isolator relay	442030
Normal/boost switch	455213
Normal/boost/purge switch	5108454
2-way switch with neon	459746
3 speed controller switch	563533
Normal / boost switch stainless	437320
Normal / boost switch with Neon	449060
LED Fault indicator	448356

Product Fiche

Name:	Vent-Axia							
Model ID (Stock Ref.)	437634C	443298B	445655B	495360	495361	407849A 496186	495362	495363
SEC Class	B		B			B		
SEC Value ('Average')	-27.2		-27			-26.9		
SEC Value ('Warm')	-11.7		-11.5			-11.4		
SEC Value ('Cold')	-54.3		-54.1			-54.0		
Label Required? (Yes/No=Out of scope)	Yes							
Declared as: RVU or NRVU/UVU or BVU	RVU/UVU							
Speed Drive	Multi Speed							
Type HRS (Recuperative, Regenerative, None)	None							
Thermal Eff: [(%), NA(if none)]	N/A							
Max. Flow Rate (m3/h)	338.8		400			505.1		
Max. Power Input (W): (@Max.Flow Rate)	43		52			85		
LWA: Sound Power Level dB)	46.4		50.7			52.2		
Ref. Flow Rate (m3/s)	0.066		0.078			0.098		
Ref. Pressure Diff. (Pa)	201		203			206		
SPI [W/(m3/h)]	0.07		0.08			0.09		
Control Factor & Control Typology: (CTRL/ Typology)								
Control Factor; CTRL	0.65							
Control Typology	Local Demand Control							
Declared: -Max Internal & External Leakage Rates(%) for BVUs or carry over (for regenerative heat exchangers only), Ext. Leakage Rates (%) for Ducted UVUs;	<5% Internal, <5% External							
Mixing Rate of Non-Ducted BVUs not intended to be equipped with one duct connection on either supply or extract air side;	N/A							
Position and description of visual filter warning for RVUs intended for use with filters, including text pointing out the importance of regular filter changes for performance and energy efficiency of the unit	N/A							
For UVUs (Instructions Install Regulated Supply/Extract Grilles Façade)	In F&W							
Internet Address (for Disassembly Instructions)	www.vent-axia.com							
Sensitivity p. Variation@+20/-20 Pa: (for Non-Ducted VUs)	N/A							
Air Tightness-ID/OD-(m3/h) (for Non-Ducted VUs)	N/A							
Annual Electricity Consumption: AEC (kWh/a)	0.4		0.5			0.6		
Annual Heating Saved: AHS (kWh/a)								
AHS: Average	28.3		28.3			28.3		
AHS: Warm	12.8		12.8			12.8		
AHS: Cold	55.4		55.4			55.4		

Disposal



This product should not be disposed of with household waste. Please recycle where facilities exist. Check with your local authority for recycling advice.

The **Vent-Axia** Guarantee

Applicable only to products installed and used in the United Kingdom. For details of guarantee outside the United Kingdom contact your local supplier.

Vent-Axia guarantees its products for two years from date of purchase against faulty material or workmanship. In the event of any part being found to be defective, the product will be repaired, or at the Company's option replaced, without charge, provided that the product: -

- Has been installed and used in accordance with the instructions given with each unit.
- Has not been connected to an unsuitable electricity supply. (The correct electricity supply voltage is shown on the product rating label attached to the unit).
- Has not been subjected to misuse, neglect or damage.
- Has not been modified or repaired by any person not authorised by the company.

IF CLAIMING UNDER TERMS OF GUARANTEE

Please return the complete product, carriage paid to your original supplier or nearest Vent-Axia Centre, by post or personal visit. Please ensure that it is adequately packed and accompanied by a letter clearly marked "Guarantee Claim" stating the nature of the fault and providing evidence of date and source of purchase.

The guarantee is offered to you as an extra benefit and does not affect your legal rights.

Vent-Axia.

Head Office: Fleming Way, Crawley, West Sussex, RH10 9YX

EU Authorised Representative: Vent-Axia Sigarenmaker 5 - 5521DJ Eersel Nederland authorisedrep@vent-axia.nl

UK NATIONAL CALL CENTRE: -

Sales Enquiries:

Tel: 0344 8560590

Email: sales@vent-axia.com

Technical Support:

Tel: 0344 8560594

Email: vatechsupport@vent-axia.com

Ventair Australia

Tel: +61 3 9775 0556

Fax: +61 39775 0775

Email: info@ventair.com.au

4 Capital Place, Carrum Downs, VIC 3201, Australia

As part of the policy of continuous product improvement Vent-Axia reserves the right to alter specifications without notice.