

NBR High Pressure Axial Fan Range

100mm 125mm & 150mm
Intermittent Axial fan range.

Installation and Wiring Instructions

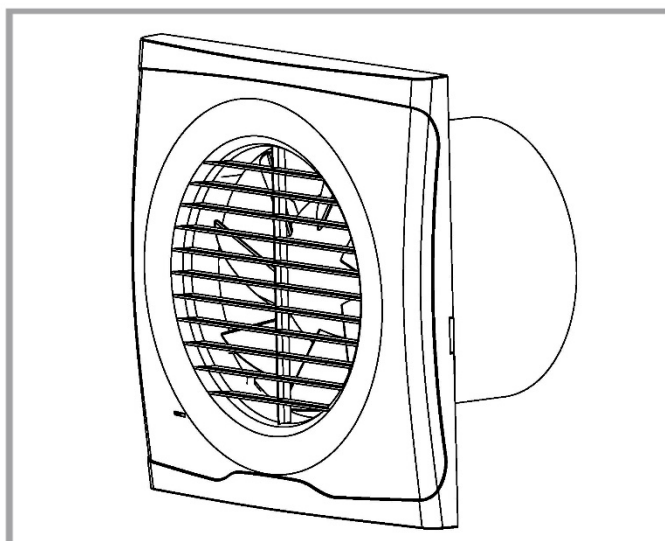

Stock Ref. N°	NBR Model
496575	100mm Basic
496576	100mm Timer
496577	100mm Humidity/Timer
496578	100mm PIR
496579	125mm Basic
496580	125mm Timer
496581	125mm Humidity/Timer
496582	150mm Basic
496583	150mm Timer
496584	150mm Humidity/Timer

220-240V~50Hz

Vent-Axia[®]

PLEASE READ INSTRUCTIONS IN CONJUNCTION WITH ILLUSTRATIONS.
PLEASE SAVE THESE INSTRUCTIONS.

IP45



Installation and Wiring Instructions for the NBR High Pressure Axial Range of Extractor Fans.



IMPORTANT: READ THESE INSTRUCTIONS BEFORE COMMENCING THE INSTALLATION

DO NOT install this product in areas where the following may be present or occur:

- Excessive oil or a grease laden atmosphere.
- Corrosive or flammable gases, liquids or vapours.
- Ambient temperatures higher than 40°C or less than -5°C.
- Possible obstructions which would hinder the access or removal of the Fan.

SAFETY AND GUIDANCE NOTES

- A.** All wiring to be in accordance with the current I.E.T. Regulations, or the appropriate standards of your country and **MUST** be installed by a suitably qualified person.
- B.** The Fan should be provided with a local isolator switch capable of disconnecting all poles, having a contact separation of at least 3mm.
- C.** Ensure that the mains supply (Voltage, Frequency, and Phase) complies with the rating label.
- D.** The Fan should only be used in conjunction with the appropriate Vent-Axia products.
- E.** The Fan should only be used in conjunction with fixed wiring.
- F.** When the Fan is used to remove air from a room containing a fuel-burning appliance, ensure that the air replacement is adequate for both the fan and the fuel-burning appliance.
- G.** The Fan should not be used where it is liable to be subject to direct water spray for prolonged periods of time.
- H.** Where ducted Fans are used to handle moisture-laden air, a condensation trap should be fitted. Horizontal ducts should be arranged to slope slightly downwards away from the Fan.
- I.** This appliance is not intended for use by persons (including children) with reduced physical, sensory or mental capabilities, or lack of experience and knowledge, unless they have been given supervision or instruction concerning use of the appliance by a person responsible for their safety.

- J.** Children should be supervised to ensure that they do not play with the appliance.
- K.** Stationary appliances not fitted with means for disconnection from the supply mains having a contact separation in all poles that provide full disconnection under over voltage category III, the instructions state that means for disconnection must be incorporated in the fixed wiring in accordance with the wiring rules.
- L.** Ensure the grille is fully engaged onto the fan chassis using all clips.

DESCRIPTION

NBR High Pressure 100 axial extract fans are suitable for domestic bathrooms and W.C's.
 The NBR High Pressure 125 and 150 axial extract fans are suitable for domestic kitchens and utility rooms. They are available as wall or panel mounted models with shutter, timer, humidity and PIR combinations.

INSTALLATION

IMPORTANT: The fan should only be used in conjunction with fixed wiring.

PANEL MOUNTING

1. For panel mounting the fan should be installed into a duct protected by an exterior air grille that must comply with the standard requirements of your country to prevent access to the fan's impeller.
2. Cut a 107mm diameter hole for 100mm fans, a 130mm hole for 125mm fans or a 155mm diameter hole for 150mm fans.
3. Push the two clips on each side of the fan and pull the grille away from the chassis.
4. Using the built in spirit level bubble as an aid, mark the screw centres through the holes in the fan back plate. Drill, plug and screw into position.
5. After installation, ensure impeller rotates freely and the shutters can open.
6. Replace the grille and ensure the clips engaged.

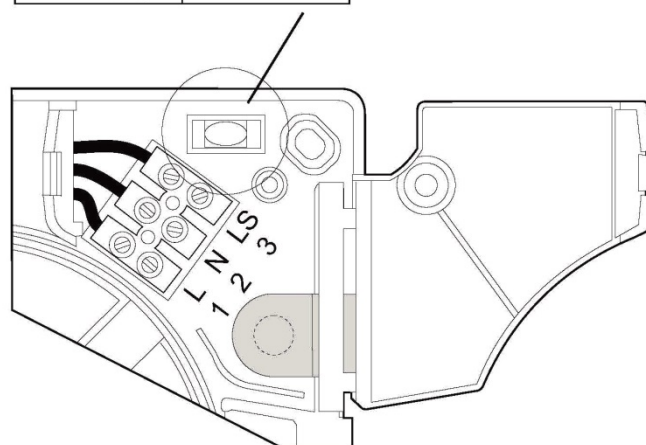
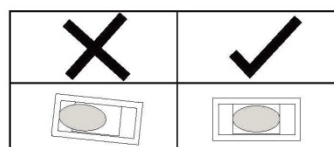

Open up the internal cover to access the spirit level bubble and terminals

WALL MOUNTING

1. For wall mounting either cut a 115mm diameter hole for 100mm fans, a 140mm hole for 125mm fans or a 170mm diameter hole for 150mm fans, through the wall and insert the wall sleeve. Slope the sleeve slightly downwards away from the fan. Cut to length and cement both ends into position flush with the wall faces.
2. Push the two clips on each side of the fan and pull the grille away from the chassis.
3. Using the built in spirit level bubble as an aid, mark the screw centres through the holes in the fan back plate. Drill, plug and screw into position. Fix exterior grille into position with the louvres positioned downwards. (Note:- The grille must comply with the standard requirements of your

country to prevent access to the fan's impeller. The wall kit used in this installation should provide a minimum ducting length of 100mm from the fans back plate to the inside of the external grille).

4. After installation, ensure impeller rotates freely and the shutters can open.
5. Replace the grille and ensure the clips engaged.

WIRING



WARNING: THE FAN AND ANCILLARY CONTROL EQUIPMENT MUST BE ISOLATED FROM THE POWER SUPPLY DURING THE INSTALLATION / OR MAINTENANCE.

IMPORTANT

- The fan should only be used in conjunction with fixed wiring.
- The cross - sectional area of supply cord used should be ranged from 1 -1.5mm².
- Cable entry can be made from the rear or side of the fan using the grommet provided.
- The extraction fan is suitable for connection to 220-240V 50Hz supply.
- The fan is a class II double insulated product and **MUST NOT** be earthed.

1. Select and follow the appropriate wiring diagram. (Fig. 1,2 or 3)
2. Check all connections have been made correctly and securely fastened.
3. Ensure the impeller rotates and is free from obstructions.

SETUP



WARNING: THE FAN AND ANCILLARY CONTROL EQUIPMENT MUST BE ISOLATED FROM THE POWER SUPPLY DURING THE INSTALLATION / OR MAINTENANCE.

NBR High Pressure Axial 100,125 & 150 Basic

Single speed fan. Controlled by remote switch (e.g. light switch or auto sensor) Fig.1.

NBR High Pressure Axial 100,125 & 150 Timer

Single speed with overrun timer. The fan can be wired to a lighting circuit switch. Fig.3. or wired for a basic on/off operation wire as Fig 2.

When switched 'ON', the fan will operate at full speed and will continue to run for a pre-set time after the switch is turned 'OFF'.

TIMER ADJUSTMENT

BEFORE ADJUSTING THE TIMER, SWITCH OFF THE MAINS SUPPLY. TIMER SHOULD ONLY BE ADJUSTED BEFORE OR DURING INSTALLATION.

1. Remove the fan grille. The controller is factory set at 15 minutes approx. The overrun time period can be adjusted from 5-30 minutes by altering the adjuster on the control PCB. Note the exact min/max time may vary between products.
2. To REDUCE the operating time, use a small screwdriver to turn the adjuster Fig.4. ANTI-CLOCKWISE.
3. To INCREASE the operating time, use a small screwdriver to turn the adjuster Fig.4. CLOCKWISE.
4. Replace the fan grille.

NBR High Pressure Axial 100mm PIR

Single speed with PIR (passive infra-red) detector and overrun timer. The fan starts automatically when a movement is detected and will continue to operate for the set overrun time period. Fig. 1.

The fan can also be wired to a lighting circuit switch. Fig.3. so it can be started by the light switch or the PIR detector.

TIMER ADJUSTMENT

BEFORE ADJUSTING THE TIMER, SWITCH OFF THE MAINS SUPPLY. TIMER SHOULD ONLY BE ADJUSTED BEFORE OR DURING INSTALLATION.

1. Remove the fan grille. The controller is factory set at 15 minutes approx. The overrun time period can be adjusted from 5-30 minutes by altering the adjuster on the control PCB.
2. To **REDUCE** the operating time, use a small screwdriver to turn the adjuster Fig.5. **ANTI-CLOCKWISE**.
3. To **INCREASE** the operating time, use a small screwdriver to turn the adjuster Fig.5. **CLOCKWISE**.
4. Replace the fan grille.

NBR High Pressure Axial 100,125 & 150 Humidity Timer

The fan contains an integral humidity controller. In automatic mode the controller switches the fan on at full speed when the room Relative Humidity (RH) increases. The fan will continue to run until the room RH falls.

These fans also include a built in timer function. This gives the fan a fixed over run time of approx. 15 mins. The timer can be deactivated by removing the Jumper JP1, (Fig. 6)

HUMIDITY SET-POINT ADJUSTMENT (25-95%RH)

BEFORE ADJUSTING THE CONTROLLER, SWITCH OFF THE MAINS SUPPLY. HUMIDISTAT SHOULD ONLY BE ADJUSTED BEFORE OR DURING INSTALLATION.

1. Remove the fan grille.
2. To **INCREASE SET POINT**, turn the adjuster **clockwise**. This will reduce the internal Relative Humidity set point at which the fan switches on. (Fig. 6)
3. To **REDUCE SET POINT**, turn the adjuster **anti-clockwise**. This will increase the internal Relative Humidity set point at which the fan switches on. (Fig. 6)

SPEED SELECTION (Humidity Timer models only)

The fan can be set to run on high or low speed depending on the installation requirements.

The fan is factory set to low speed with jumper JP2 fitted. To activate the high speed setting remove jumper JP2. (Fig. 6)



WARNING: THE FAN AND ANCILLARY CONTROL EQUIPMENT MUST BE ISOLATED FROM THE POWER SUPPLY DURING MAINTENANCE.

1. At intervals appropriate to the installation, the fan should be inspected and cleaned to ensure there is no build up of dirt or other deposits.
2. Wipe the inlets and front face with a damp cloth until clean.

The fan has sealed for life bearings, which do not require lubrication.

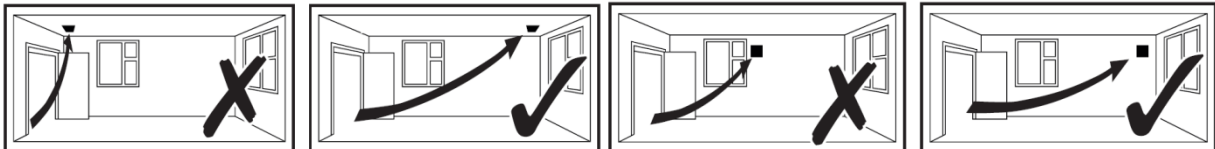
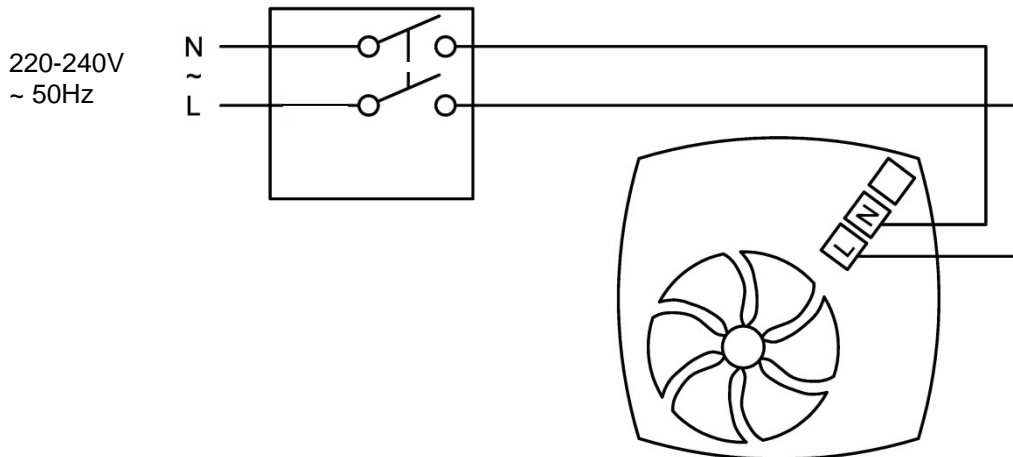

Fig.1: NBR High Pressure Axial 100,125,150 Basic and 100 PIR



**Fig.2: NBR High Pressure Axial 100,125,150 Timer models
100,125,150 Humidity Timer models (Timer /Humidistat disabled)**

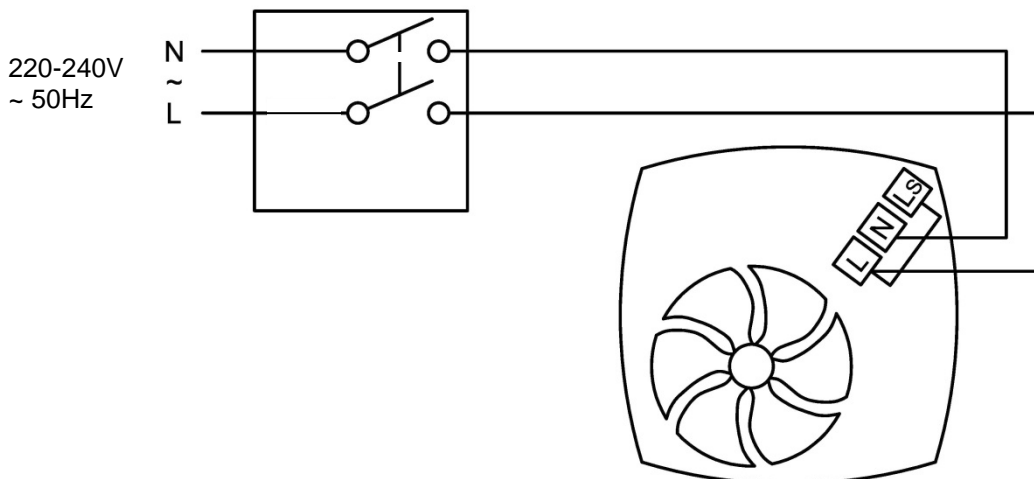

Fig.3: NBR High Pressure Axial 100,125,150 Timer, 100 PIR and 100,125,150 Humidity Timer Models

220-240V ~ 50Hz

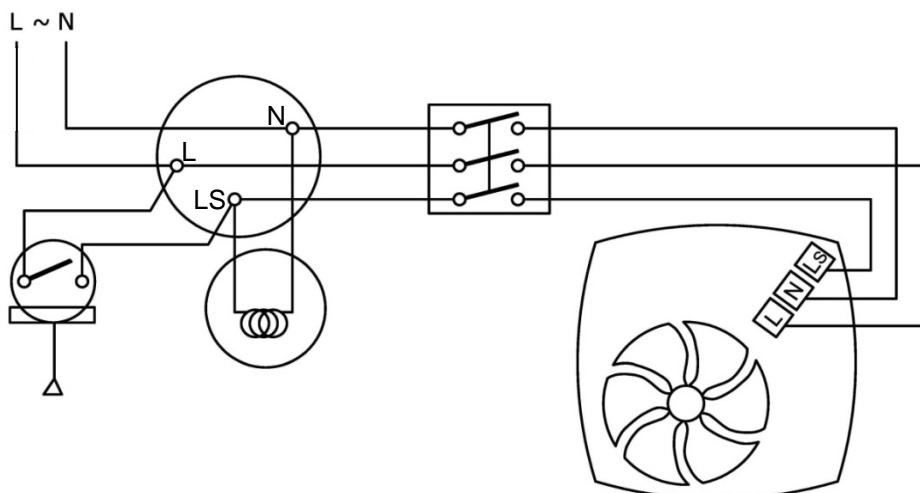
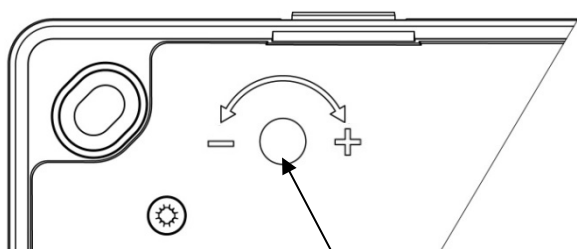

FIG. 4: TIMER



Timer Adjustment

Timer Adjustment

To **REDUCE** the operating time, use a small screwdriver to turn the adjuster **ANTI-CLOCKWISE**.
To **INCREASE** the operating time, use a small screwdriver to turn the adjuster **CLOCKWISE**.

FIG. 5: PIR TIMER

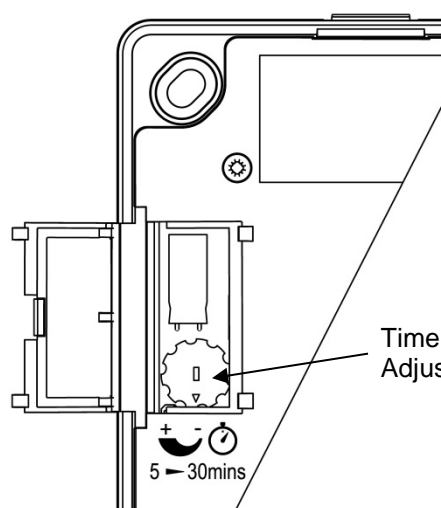

Timer Adjustment

Timer Adjustment

To **REDUCE** the operating time, use a small screwdriver to turn the adjuster **ANTI-CLOCKWISE**.
To **INCREASE** the operating time, use a small screwdriver to turn the adjuster **CLOCKWISE**.



Disposal

This product should not be disposed of with household waste. Please recycle where facilities exist. Check with your local authority for recycling advice

FIG. 6: HUMIDISTAT-TIMER

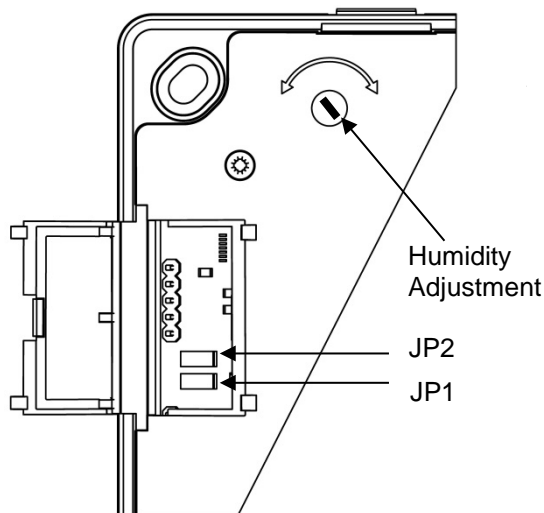

Humidity Adjustment (25-95%RH)

To **INCREASE SET POINT**, turn the adjuster **clockwise**. This makes the controller **LESS** sensitive.
To **REDUCE SET POINT**, turn the adjuster **anti-clockwise**. This makes the controller **MORE** sensitive.

Speed selection (JP2).

The fan is factory set to low speed with jumper JP2 fitted. To activate the high speed setting remove jumper JP2.

Timer Function (JP1)

JP1 to deactivate the timer, remove the jumper.
15min. timer = jumper in.
No timer = jumper out.

The **Vent-Axia** Guarantee

Applicable only to products installed and used in the United Kingdom. For details of guarantee outside the United Kingdom contact your local supplier.

Vent-Axia guarantees this product for 5 years from date of purchase against faulty material or workmanship. In the event of any part being found to be defective, the product will be repaired, or at the Company's option replaced, without charge, provided that the product:-

- Has been installed and used in accordance with the instructions given with each unit.
- Has not been connected to an unsuitable electricity supply. (The correct electricity supply voltage is shown on the product rating label attached to the unit).
- Has not been subjected to misuse, neglect or damage.
- Has not been modified or repaired by any person not authorised by the company.

IF CLAIMING UNDER TERMS OF GUARANTEE

Please return the complete product, carriage paid to your original supplier or nearest Vent-Axia Centre, by post or personal visit. Please ensure that it is adequately packed and accompanied by a letter clearly marked "Guarantee Claim" stating the nature of the fault and providing evidence of date and source of purchase.

The guarantee is offered to you as an extra benefit, and does not affect your legal rights

Vent-Axia

Head Office: Fleming Way, Crawley, West Sussex, RH10 9YX.

UK NATIONAL CALL CENTRE

SALES ENQUIRIES: Tel: 0344 856 0590 Email: sales@vent-axia.com
TECHNICAL SUPPORT: Tel: 0344 856 0594 Email: vatechsupport@vent-axia.com

EU Authorised Representative: Vent-Axia Sigarenmaker 5 - 5521DJ Eersel Nederland authorisedrep@vent-axia.nl
For details of the warranty and returns procedure please refer to www.vent-axia.com or write to Vent-Axia, Fleming Way, Crawley, RH10 9YX